

Safety electrohydraulics

Proportional & on-off valves, cartridges, servocylinders and blocks certified according to safety directives

**SAFETY
CERTIFIED**

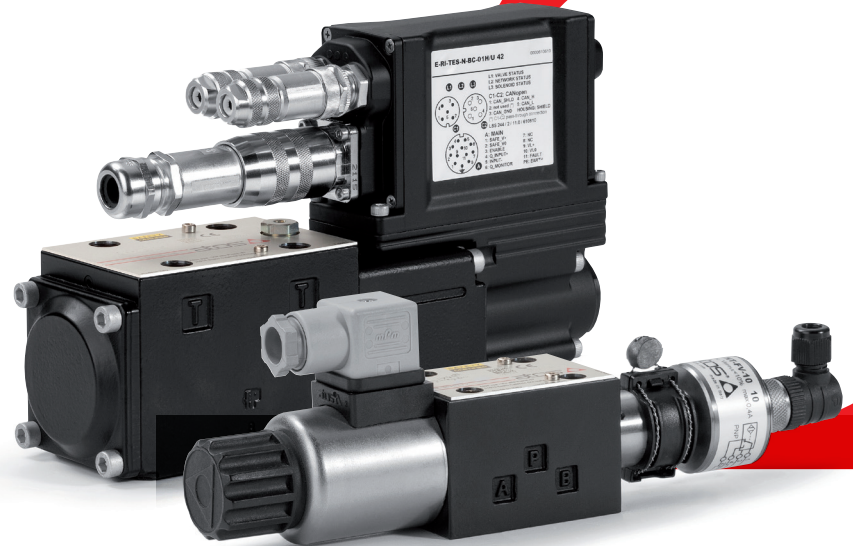

atos[®] 
the Italian electrohydraulics

Safety components range

Atos is the only worldwide brand offering a full range of electrohydraulics safety components TÜV certified to **Machine Directive 2006/42/EC, IEC 61508, ISO 13849**

- digital proportional directional valves
- solenoid valves, screw-in and ISO cartridges
- control blocks for vertical presses
- servocylinders with integral transducer

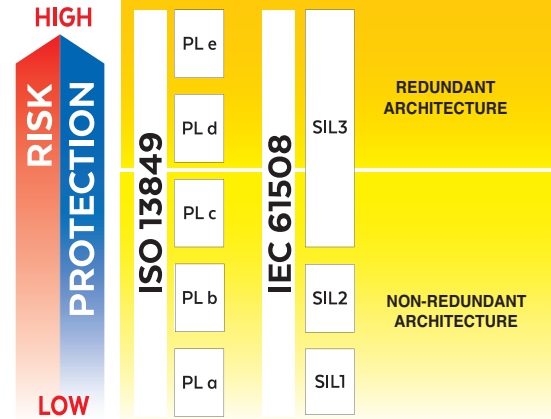

Safety Integrity Level (SIL) & Performance Level (PL) states the max acceptable level of risk in process control systems, in order to reduce hazardous events

Safety proportional valves

Proportional directional valves combining safety functions to standard functionalities

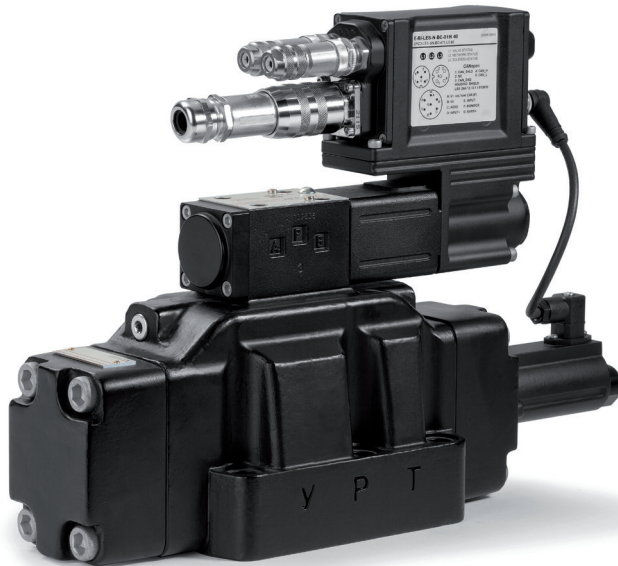

DIRECT & PILOTED

Safety by double power supply

The separate power supply for electronics and coils allows the electronics to remain active and monitor the spool safety position when coils power supply is externally cut, to operate in safety conditions

Safety by acknowledge signal

Upon valve's disable command input, to operate in safety conditions, the electronics monitor remains active to detect the spool safety position and confirm it through on-off output signal

 **ISO sizes** 06 • 10 • 16 • 25 • 32 • 35
Q_{max} 80 ÷ 3.500 l/min • **P_{max}** 350 bar

IEC 61508 up to SIL 2 / SIL 3
ISO 13849 up to category 4, PL e

Inductive safety sensors

Contactless sensors for spool or poppet position monitoring

FV inductive position switch

- NC and NO output
- Pmax 400 bar

FI inductive proximity sensor

- NC or NO output
- Pmax 100 bar for valves, 500 bar for cartridges

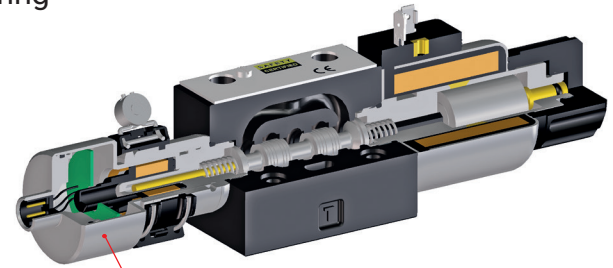

FV INDUCTIVE POSITION SWITCH

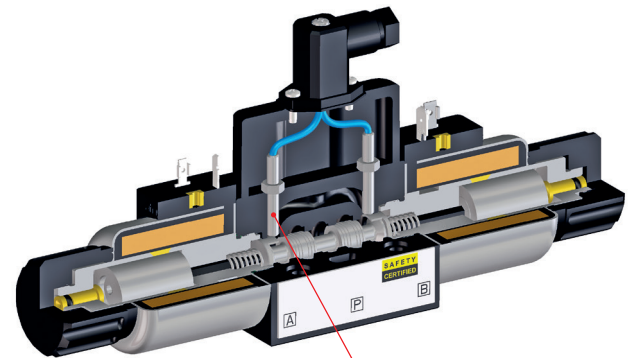
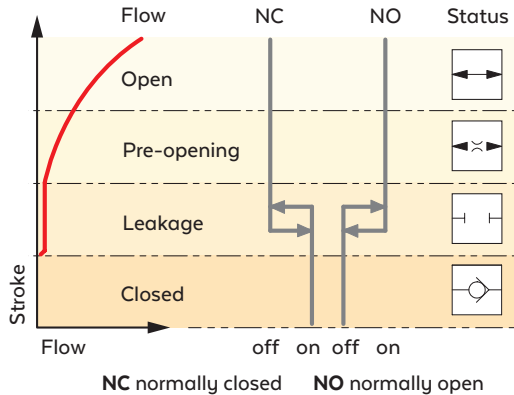

FI INDUCTIVE PROXIMITY SENSOR

The spool position monitor signal switches its status from safe condition to unsafe condition

Machine Directive 2006/42/EC

Safety solenoid valves

Machine Directive 2006/42/EC

On-off directional valves with inductive safety sensors that monitor the spool position to operate in safety conditions



DIRECT



MODULAR

ISO sizes 06 • 10
Q_{max} 80 ÷ 150 l/min • **P_{max}** 350 bar

ISO size 06
Q_{max} 60 l/min • **P_{max}** 350 bar

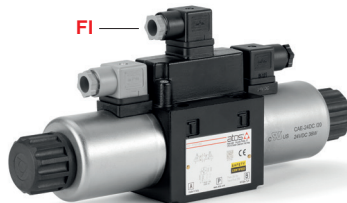

DIRECT



PILOTED

ISO sizes 06 • 10
Q_{max} 80 ÷ 150 l/min • **P_{max}** 350 bar

ISO sizes 10 • 16 • 25
Q_{max} 160 ÷ 700 l/min • **P_{max}** 350 bar

Safety cartridges

Machine Directive 2006/42/EC

On-off cartridges with inductive safety sensors that monitor the poppet position to operate in safety conditions

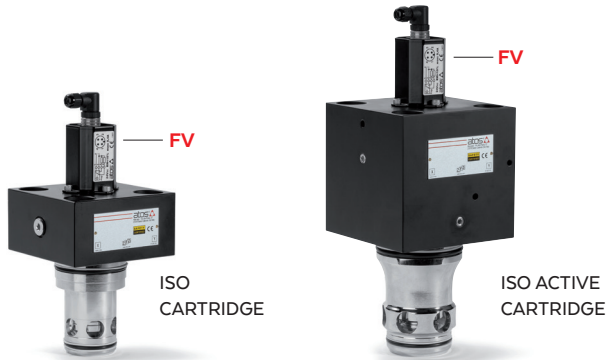

ISO sizes 16 • 25 • 32 • 40 • 50 • 63 • 80 • 100
Qmax 290 ÷ 16.000 l/min • Pmax 420 bar

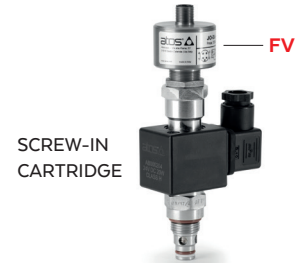

ISO sizes 3/4" • 7/8" • 1 5/16"
Qmax 40 ÷ 300 l/min • Pmax 350 bar



ISO sizes 16 • 25 • 32 • 40 • 50
Qmax 290 ÷ 4.000 l/min • Pmax 420 bar

Safety hydraulic blocks

Control blocks for vertical presses, TÜV certified

CNC synchronized press brakes

- open or closed loop proportional controls
- for presses from 400 to 15.000 kN

Torque bar press brakes

- for presses from 400 to 10.000 kN

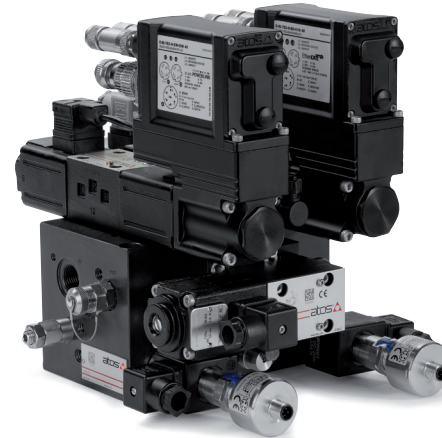

ISO 12622
ISO 13849

CNC PRESS BRAKES BLOCK

Safety servocylinders

Servocylinders with certified magnetostrictive transducers, suitable for harsh environments

SERVOCYLINDER

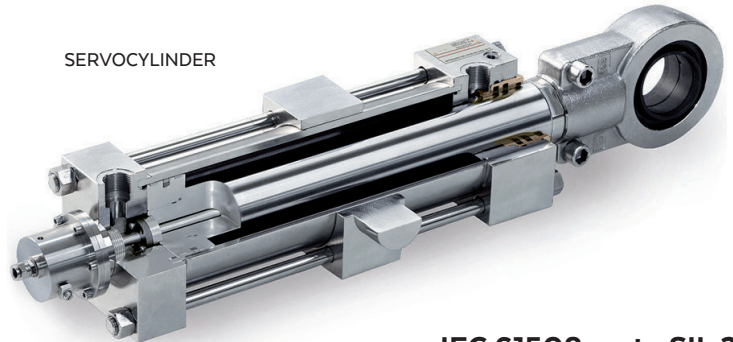

IEC 61508 up to SIL 2

Max stroke 5 m • Ømax 200 mm
Speed 2 m/sec • Pmax 320 bar



Atos regularly holds technical training courses on digital electrohydraulics
Our specialists are available for on-site technical support at customer locations



Atos spa

Italy - 21018 Sesto Calende

phone +39 0331 918370

info@atos.com

www.atos.com