

# Proportional directional valves high performance

**digital**, direct operated, with position transducer and **positive spool overlap**, rugged design

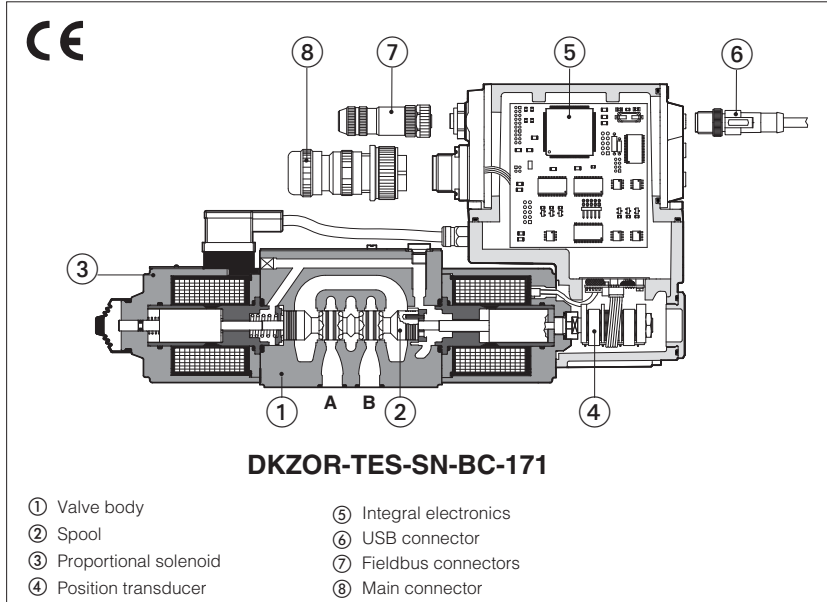

**DHZO-TEB, DHZO-TES  
DKZOR-TEB, DKZOR-TES**

High performance direct operated digital proportional valves specifically designed for high speed closed loop controls. They are equipped with LVDT position transducer and positive spool overlap for best dynamics in directional controls and not compensated flow regulations. The integral digital electronic driver performs the valve's hydraulic regulation according to the reference signal and assures valve-to-valve interchangeability thanks to the factory presetting. High performances valves are available in TEB basic execution with analog reference signals and USB port for software functional parameters setting or in TES full execution which includes also optional alternated P/Q controls and fieldbus interfaces for functional parameters setting, reference signals and real-time diagnostics.

Size: **06** and **10**  
Max flow: up to **80** and **170 l/min**  
Max pressure: **350 bar** (DHZO)  
**315 bar** (DKZOR)

**1 MODEL CODE for STANDARD SPOOLS**

<b>DHZO</b>	-	<b>T</b>	-	<b>ES</b>	-	<b>SN</b>	-	<b>NP</b>	-	<b>0</b>	<b>71</b>	-	<b>L</b>	<b>5</b>	/	<b>*</b>	<b>*</b>	/	<b>*</b>
<p><b>DHZO</b> = size 06 <b>DKZOR</b> = size 10</p> <p><b>T</b> = closed-loop one LVDT transducer</p> <p><b>Integral digital drivers:</b> <b>EB</b> = basic (1) <b>ES</b> = full</p> <p><b>Alternated P/Q controls</b>, see section 8: <b>SN</b> = none (1) <b>SP</b> = pressure control (1 pressure transducer) <b>SF</b> = force control (2 pressure transducers) <b>SL</b> = force control (1 load cell)</p> <p><b>Fieldbus interfaces</b>, USB port always present: <b>NP</b> = Not present (1) <b>BC</b> = CANopen      <b>EH</b> = EtherCAT <b>BP</b> = PROFIBUS DP    <b>EI</b> = EtherNet/IP <b>EW</b> = POWERLINK    <b>EP</b> = PROFINET IRT</p> <p>Valve size, ISO 4401: <b>0</b> = 06    <b>1</b> = 10</p>																			
<p>Seals material, see sect. 9, 10: - = NBR <b>PE</b> = FKM <b>BT</b> = HNBR</p> <p>Series number</p>																			

**Hydraulic options**, see section 14:  
**B** = solenoid with integral electronics and position transducer at side of port A (3)  
**Y** = external drain

**Electronic options**, see section 15:  
Note: **F, Q, Z** options are standard for **SP, SF, SL**  
**C** = current feedback for pressure transducer 4÷20mA (omit for std voltage ±10Vdc) only **TES-SP, SF, SL**  
**F** = fault signal - only **TEB** and **TES-SN**  
**I** = current reference input and monitor 4÷20mA (omit for standard ±10Vdc)  
**Q** = enable signal - only **TEB** and **TES-SN**  
**Z** = double power supply, enable, fault and monitor signals - 12 pin connector (4)

**Safety option** TUV certified - only **TES**:  
**U** = safe double power supply  
See section 8 and tech table **FY100**

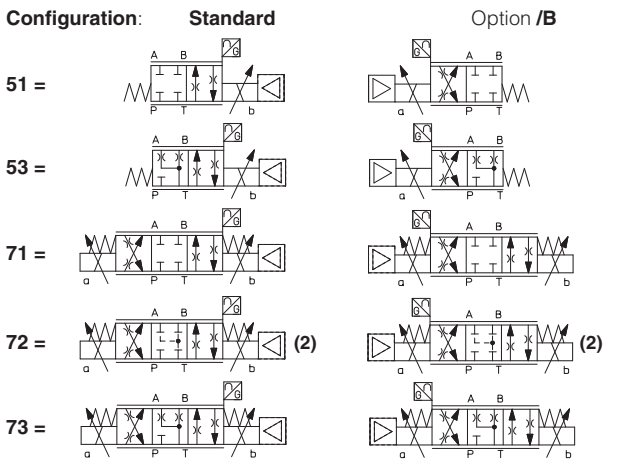

**Spool size:** 14 (L)    1 (L)    2 (S)    3 (L,S,D)    5 (L,S,D)

DHZO =	1	4,5	8	17	28
DKZOR =	-	-	-	45	75

Nominal flow (l/min) at Δp 10bar P-T

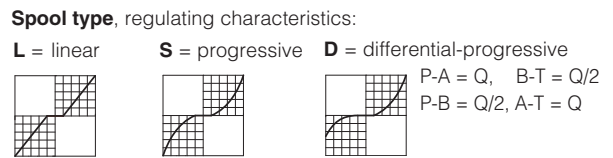

(1) **TEB** available only in version **SN-NP**  
(2) only for **DKZOR-S5** the spool overlapping type 2 provides the same characteristic of type 1, but in central position the internal leakages from P to A and B are drained to tank, avoiding the drift of cylinders with differential areas.

(3) In standard configuration the solenoid with integral electronics and position transducer are at side of port B  
(4) double power supply only for **TES**

**2 MODEL CODE for OPTIONAL SPOOLS** - refer to section 1 for valve model code and options

**DHZO** - **TES** - **SP** - **NP** - **0** **73 - V9** / \* / \* / \*

**Configuration, spool type and size:**

**73-Q5**

**73-Q5/B**

**73-V9**

**73-V9/B**

Spool size:	Q5	V9
DHZO	= 30	30
DKZOR	= 75	75

Nominal flow (l/min) at Δp 10 bar P-T

**Q5**

For alternate P/Q control see section 13, diagram 16

**V9**

For alternate P/Q control of injection cycle in plastic machinery see section 13, diagram 17

**3 GENERAL NOTES**

Atos digital proportionals valves are CE marked according to the applicable directives (e.g. Immunity and Emission EMC Directive). Installation, wirings and start-up procedures must be performed according to the general prescriptions shown in tech table **F003** and in the user manuals included in the E-SW-\* programming software.

**4 VALVE SETTINGS AND PROGRAMMING TOOLS** - see tech. table **GS001**

Valve's functional parameters and configurations, can be easily set and optimized using Atos E-SW programming software connected via USB port to the digital driver. For fieldbus versions, the software permits valve's parameterization through USB port also if the driver is connected to the central machine unit via fieldbus.

The main setting of valve's functional parameters and configurations are:

- bias, scale, ramps, dither
- linearization function for the hydraulic regulation
- setting of PID gains
- selection of analog IN / OUT range
- complete diagnostics of driver status
- internal oscilloscope function
- in field firmware update through USB port

The software is available in different versions according to the driver's options:

<b>E-SW-BASIC</b>	support:	NP (USB)	PS (Serial)	IR (Infrared)
<b>E-SW-FIELDBUS</b>	support:	BC (CANopen)	BP (PROFIBUS DP)	EH (EtherCAT)
		EW (POWERLINK)	EI (EtherNet/IP)	EP (PROFINET IRT)
<b>E-SW-*/PQ</b>	support:	valves with SP, SF, SL alternated control (e.g. E-SW-BASIC/PQ)		

**WARNING: drivers USB port is not isolated!**  
The use of isolator adapter is highly recommended for PC protection (see table **GS500**)

**USB connection**

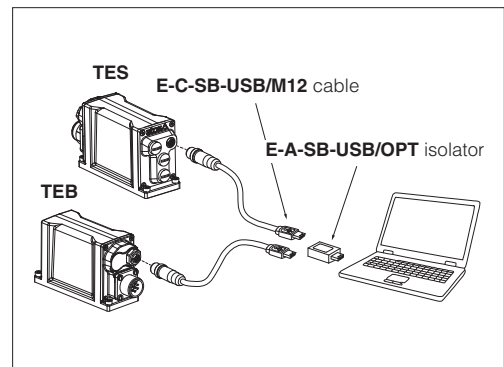

**5 FIELDBUS** - only for **TES**, see tech. table **GS510**

Fieldbus allows valve direct communication with machine control unit for digital reference, valve diagnostics and settings. These execution allow to operate the valves through fieldbus or analog signals available on the main connector.

**6 ALTERNATED P/Q CONTROLS** - only for **TES**, see tech. table **GS212**

**S\*** options add the closed loop control of pressure (**SP**) or force (**SF** and **SL**) to the basic functions of proportional directional valves flow regulation. A dedicated algorithm alternates pressure (force) depending on the actual hydraulic system conditions. An additional connector is available for transducers to be interfaced to the valve's driver (1 pressure transducer for SP, 2 pressure transducers for SF or 1 load cell for SL). The alternated pressure control (SP) is possible only for specific installation conditions. Main 12 pin connector is the same as /Z option plus two analog signals specific for the pressure (force) control.

**7 AXIS CONTROLLER** - see tech. table **FS230**

Digital servoproportional with integral electronics **TEZ** include valve's driver plus axis controller, performing position closed loop of any hydraulic actuator equipped with analog, encoder or SSI position transducer. **S\*** option add alternated P/Q control to the basic position ones. Atos also supplies complete servoactuators integrating servocylinder, digital servoproportional valve and axis controller, fully assembled and tested. For more information consult Atos Technical Office.

**8 SAFETY OPTION** - only for **TES**, see tech. table **FY100**

Atos range of proportional directional valves, provides functional safety option **/U**, designed to accomplish a safety function, intended to reduce the risk in process control systems.

It is **TUV certified** in compliance to **IEC 61508 up to SIL 3** and **ISO 13849 up to category 4, PL e**  
**Safe double power supply**, option **/U**: the driver has separate power supplies for logic and solenoids



**9 SEALS AND HYDRAULIC FLUID** - for other fluids not included in below table, consult Atos Technical Office

Seals, recommended fluid temperature	NBR seals (standard) = -20°C ÷ +60°C, with HFC hydraulic fluids = -20°C ÷ +50°C FKM seals (/PE option) = -20°C ÷ +80°C HNBR seals (/BT option) = -40°C ÷ +60°C, with HFC hydraulic fluids = -40°C ÷ +50°C		
Recommended viscosity	20 ÷ 100 mm²/s - max allowed range 15 ÷ 380 mm²/s		
Fluid contamination class	ISO 4406 class 20/18/15 NAS 1638 class 9, in line filters of 10 μm (β10 ≥ 75 recommended)		
<b>Hydraulic fluid</b>	<b>Suitable seals type</b>	<b>Classification</b>	<b>Ref. Standard</b>
Mineral oils	NBR, FKM, HNBR	HL, HLP, HLPD, HVL, HVLDP	DIN 51524
Flame resistant without water	FKM	HFDR, HFDR	ISO 12922
Flame resistant with water	NBR, HNBR	HFC	

## 10 GENERAL CHARACTERISTICS

Assembly position	Any position
Subplate surface finishing	Roughness index, Ra 0,4 flatness ratio 0,01/100 (ISO 1101)
MTTFd values according to EN ISO 13849	150 years, see technical table P007
Ambient temperature range	<b>standard</b> = -20°C ÷ +60°C <b>/BT option</b> = -40°C ÷ +60°C
Storage temperature range	<b>Standard</b> = -20°C ÷ +70°C <b>/BT option</b> = -40°C ÷ +70°C

## 11 HYDRAULIC CHARACTERISTICS - based on mineral oil ISO VG 46 at 50 °C

Valve model	DHZO						DKZOR		
Pressure limits [bar]	ports <b>P, A, B</b> = 350; <b>T</b> = 210 (250 with external drain /Y); <b>Y</b> = 10						ports <b>P, A, B</b> = 315; <b>T</b> = 210 (250 with external drain /Y); <b>Y</b> = 10		
Spool type	<b>L14</b>	<b>L1</b>	<b>S2</b>	<b>L3,S3,D3</b>	<b>L5,S5,D5</b>	<b>Q5,V9</b>	<b>L3,S3,D3</b>	<b>L5,S5,D5</b>	<b>Q5,V9</b>
Nominal flow [l/min] <b>(1)</b>									
Δp= 10 bar	1	4,5	8	18	28	30	45	75	75
Δp P-T									
Δp= 30 bar	1,7	8	14	30	50	52	80	130	130
max									
Δp= 70 bar	2,6	12	21	45	75	80	120	170	170
permissible flow <b>(2)</b>	4	18	30	50	80	80	130	180	180
Response time [ms] (0-100% step signal)	15						20		
Leakage [cm <sup>3</sup> ]	<30 (at p = 100 bar); <135 (at p = 350 bar)						<80 (at p = 100 bar); <600 (at p = 315 bar)		
Hysteresis	≤ 0,2 [% of max regulation]								
Repeatability	± 0,1 [% of max regulation]								
Thermal drift	zero point displacement < 1% at ΔT = 40°C								

**Notes:** **(1)** For different Δp, the max flow is in accordance to the diagrams in section 13.2  
**(2)** See detailed diagrams in section 13.2

## 12 ELECTRIC CHARACTERISTICS

Power supplies	Nominal : +24 VDC Rectified and filtered : VRMS = 20 ÷ 32 VMAX (ripple max 10 % VPP)			
Max power consumption	50 W			
Reference input signals	Voltage: range ±10 VDC (24 VMAX tollerant)		Input impedance: Ri > 50 kΩ	
	Current: range ±20 mA		Input impedance: Ri = 500 Ω	
Coil resistance R at 20°C	<b>DHZO</b> = 3 ÷ 3,3 Ω		<b>DKZOR</b> = 3,8 ÷ 4,1 Ω	
Insulation class	H (180°) Due to the occurring surface temperatures of the solenoid coils, the European standards ISO 13732-1 and EN982 must be taken into account			
Max. solenoid current	<b>DHZO</b> = 2,6 A		<b>DKZOR</b> = 3 A	
Monitor outputs	Output range: voltage ±10 VDC @ max 5 mA current ±20 mA @ max 500 Ω load resistance			
Enable input	Range: 0 ÷ 5 Vdc (OFF state), 9 ÷ 24 Vdc (ON state), 5 ÷ 9 Vdc (not accepted); Input impedance: Ri > 10 kΩ			
Fault output	Output range: 0 ÷ 24 Vdc (ON state > [power supply - 2 V] ; OFF state < 1 V ) @ max 100 mA; external negative voltage not allowed (e.g. due to inductive loads)			
Alarms	Solenoid not connected/short circuit, cable break with current reference signal, over/under temperature, valve spool transducer malfunctions			
Format	Sealed box on the valve; IP66 / IP67 protection degree with mating connectors			
Tropicalization	Tropical coating on electronics PCB			
Operating temperature	-40 ÷ +60 °C (storage -40 ÷ +70 °C)			
Mass (driver only)	Approx. 490 g			
Additional characteristics	Short circuit protection of solenoid's current supply; 3 leds for diagnostic; spool position control by P.I.D. with rapid solenoid switching; protection against reverse polarity of power supply			
Electromagnetic compatibility (EMC)	According to Directive 2014/30/UE (Immunity: EN 61000-2; Emission: EN 61000-3)			
Communication interface	USB	CANopen	PROFIBUS DP	EtherCAT, POWERLINK, EtherNet/IP, PROFINET IO RT / IRT
	Atos ASCII coding	EN50325-4 + DS408	EN50170-2/IEC61158	EC 61158
Communication physical layer	not insulated USB 2.0 + USB OTG	optical insulated CAN ISO11898	optical insulated RS485	Fast Ethernet, insulated 100 Base TX
Recommended wiring cable	LiYCY shielded cables, see section 20			

**Note:** a minimum booting time between 400 and 800 ms has been considered from the driver energizing with the 24 Vdc power supply before the valve has been ready to operate. During this time the current to the valve coils is switched to zero

**13** **DIAGRAMS** - based on mineral oil ISO VG 46 at 50 °C

**13.1 Regulation diagrams** - values measure at  $\Delta p$  30 bar P-T

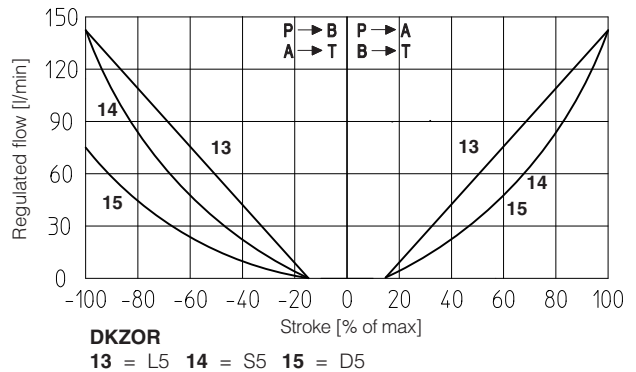
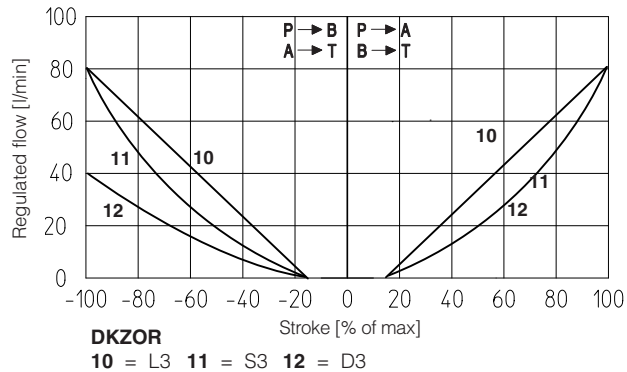
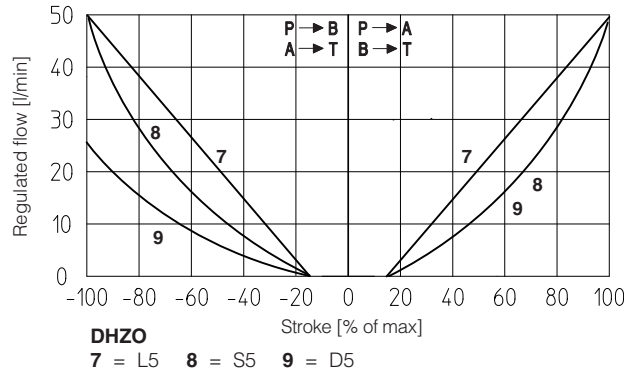
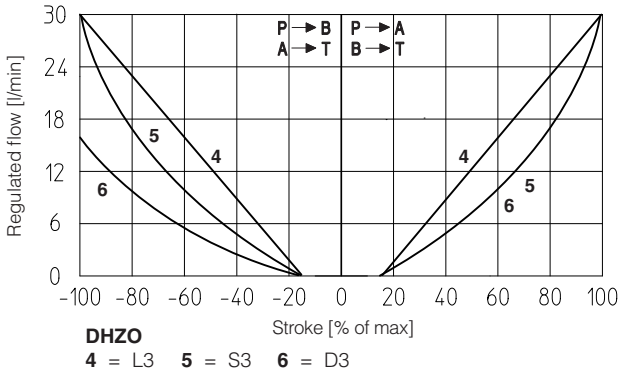
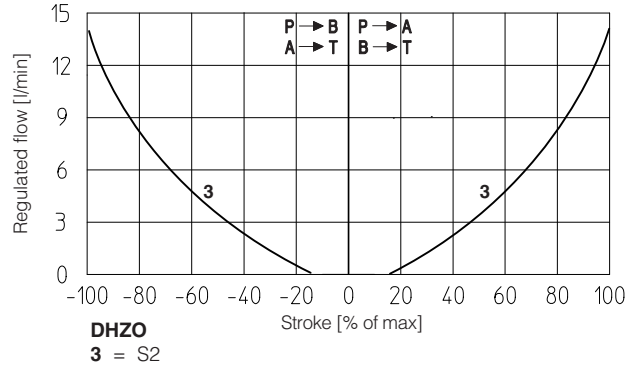
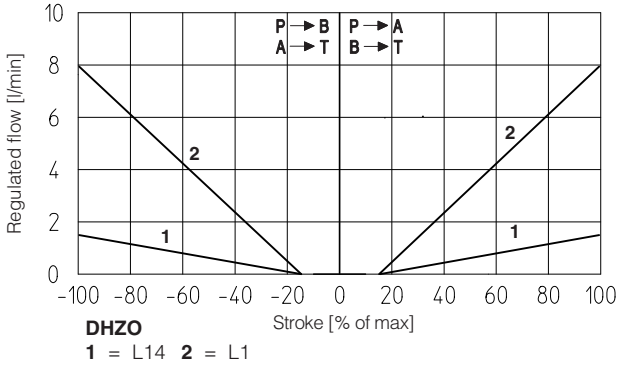

**Note:**

Hydraulic configuration vs. reference signal for configurations 71, 72 and 73 (standard and option /B)

Reference signal  $\left. \begin{matrix} 0 \div +10 \text{ V} \\ 12 \div 20 \text{ mA} \end{matrix} \right\} P \rightarrow A / B \rightarrow T$

Reference signal  $\left. \begin{matrix} 0 \div -10 \text{ V} \\ 12 \div 4 \text{ mA} \end{matrix} \right\} P \rightarrow B / A \rightarrow T$

**16 = linear spool Q5**

Q5 spool type is specific for alternate P/Q controls in combination with S\* option of digital integral drivers (see tech table **GS212**). It allows to control the pressure in A port or B port and it provides a safety central position (A-T/B-T) to depressurize the actuator chambers.

The strong meter-in characteristic makes the spool suitable for both pressure control and motion regulations in several applications.

**17 = differential - progressive spool V9**

V9 spool type is specific for alternate P/Q controls in combination with S\* option of digital integral drivers (see tech table **GS212**) or Z-ME-KZ/GI axis card (see tech table **G345**).

This spool is specially designed to manage the whole injection cycle in plastic machinery, thanks to the following specific features:

- strong meter-in characteristic to allow the pressure control in A port during the holding pressure (P-A) and the plasticizing (A-T) phases
- safety central position (A-T/B-T) to depressurize the actuator chambers
- large A-T and B-T flow capability, required during the plasticizing phase, to discharge big volumes from high differential injection cylinders with low pressure drops and permitting the contemporary oil suction from tank

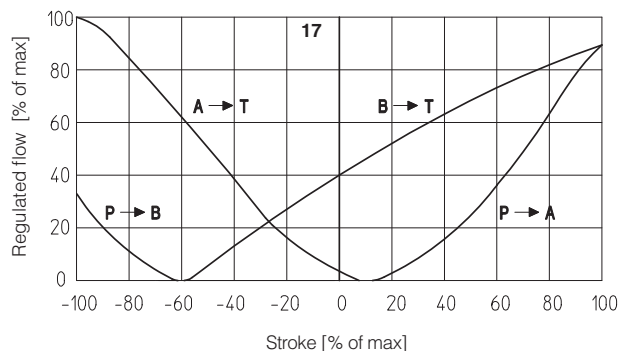
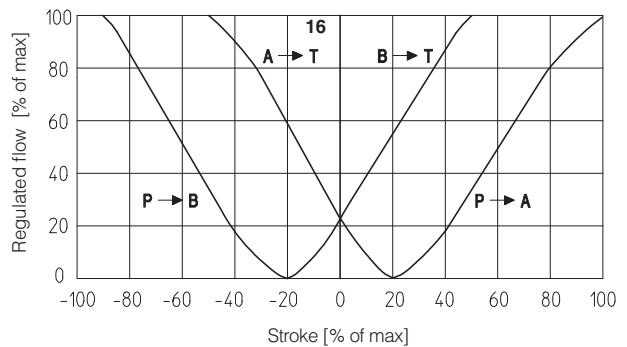

### 13.2 Flow /Dp diagrams

stated at 100% of valve stroke

#### DHZO

- 1 = spool L14
- 2 = spool L1
- 3 = spool S2
- 4 = spool L3, S3, D3
- 5 = spool L5, S5, D5, V9

#### DKZOR

- 6 = spool S3, L3, D3
- 7 = spool S5, L5, D5, V9

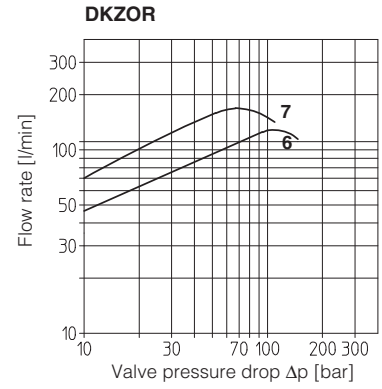
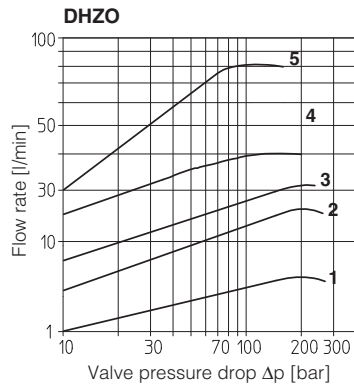

### 13.3 Operating limits

#### DHZO

- 1 = spool L14
- 2 = spool L1
- 3 = spool S2
- 4 = spool L3, S3, D3
- 5 = spool L5, S5, D5, V9

#### DKZOR

- 6 = spool S3, L3, D3
- 7 = spool S5, L5, D5, V9

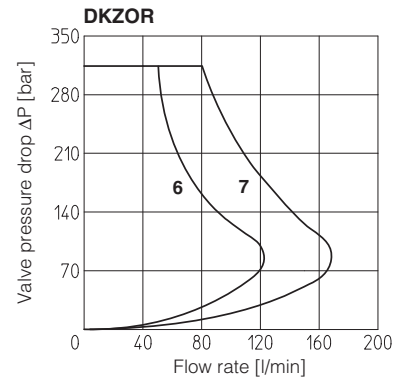
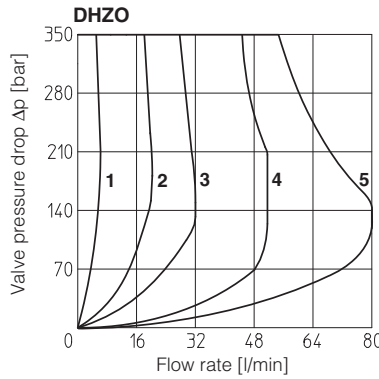

### 13.4 Response time

The response times in below diagrams are measured at different steps of the reference input signal. They have to be considered as average values. For the valves with digital electronics the dynamics performances can be optimized by setting the internal software parameters.

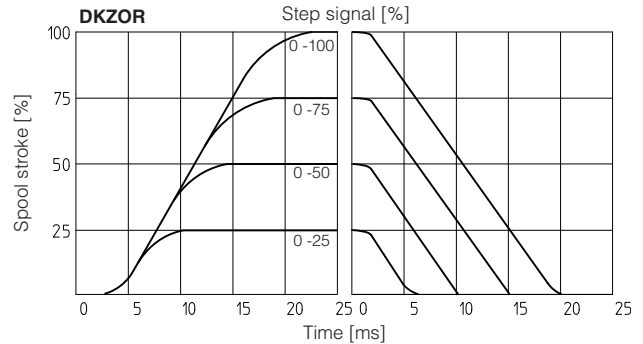
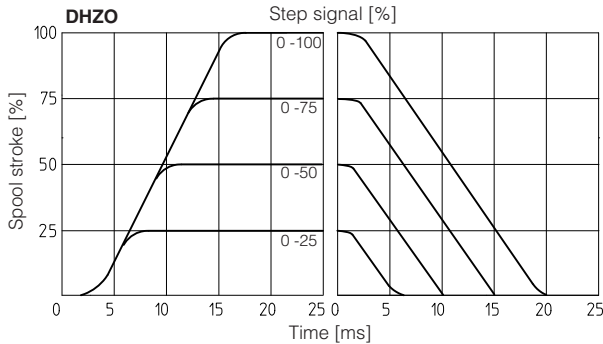

### 13.5 Bode diagrams

- 1 = 10% ↔ 90% nominal stroke
- 2 = 50% ± 5% nominal stroke

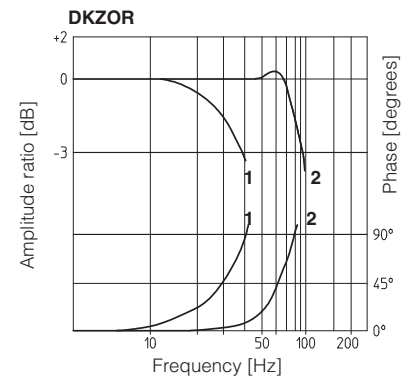
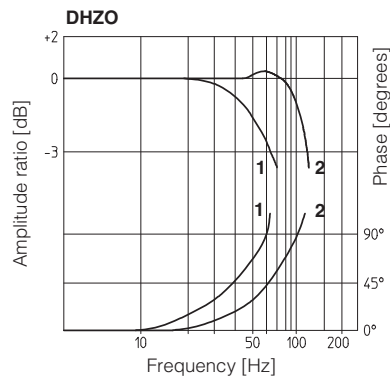

### 13.6 Operation as throttle valve

Single solenoid valves configuration  
51 and 53 can be used as simple  
throttle valves:  
Pmax = 250 bar (option /Y advisable)

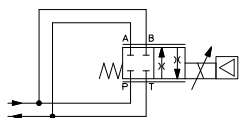

Max flow Δp= 30bar [l/min]	SPOOL TYPE				
	L14	L1	S2	L3 S3	L5 S5
<b>DHZO</b>	4	16	28	60	100
<b>DKZOR</b>	-	-	-	160	260

## 14 HYDRAULIC OPTIONS

### 14.1 Option /B

Solenoid, integral electronics and position transducer at side of port A of the main stage. For hydraulic configuration vs reference signal, see 13.1

### 14.2 Option /Y

Option /Y is mandatory if the pressure in port T exceeds 210 bar.

## 15 ELECTRONIC OPTIONS

### 15.1 Option /F (for **TEB** and **TES-SN**; standard for **TES-SP, SF, SL** with fieldbus)

This option permits to monitor the eventual fault condition of the driver, as for example the solenoid short circuit/not connected, reference signal cable broken for option /I, spool position transducer broken, etc. - see 17.9 for signal specifications.

### 15.2 Option /I (for all version)

It provides 4 ÷ 20 mA current reference and monitor signals, instead of the standard ±10 VDC.

Input signal can be reconfigured via software selecting between voltage and current, within a maximum range of ±10 VDC or ±20 mA.

It is normally used in case of long distance between the machine control unit and the valve or where the reference signal can be affected by electrical noise; the valve functioning is disabled in case of reference signal cable breakage.

### 15.3 Option /Q (for **TEB** and **TES-SN**; standard for **TES-SP, SF, SL** with fieldbus)

This option permits to inhibit the valve function without removing the power supply to the driver. Upon disable command the current to the solenoid is zeroed and the valve's spool moves to rest position.

The option /Q is suggested for all cases where the valve has to be frequently inhibited during the machine cycle - see 17.7 for signal specifications.

### 15.4 Option /Z (for **TEB** and **TES-SN**; standard for **TES-SP, SF, SL** with fieldbus)

It provides, on the 12 pin main connector, the following additional features:

**Fault output signal**, see above option /F

**Enable input signal**, see above option /Q

**Repeat enable output signal** - only for **TEB**

**Power supply for driver's logics and communication** - only for **TES**

Separate power supply (pin 9,10) allows to cut solenoid power supply (pin 1,2) while maintaining active diagnostics, USB and fieldbus communication.

A safety fuse is required in series to each driver power supply: 500 mA fast fuse.

### 15.5 Options /C - only for **SP, SF, SL**

Option /C is available to connect pressure (force) transducers with 4 ÷ 20 mA current output signal, instead of the standard ±10 VDC.

Input signal can be reconfigured via software selecting between voltage and current, within a maximum range of ±10 VDC or ±20 mA.

## 16 POSSIBLE COMBINED OPTIONS:

Standard versions:

For SN: **/FI, /IQ, /IZ**

For SP, SF, SL: **/CI**

Safety certified versions:

For SN: **/IU**

For SP, SF, SL: **/CU, IU, CIU**

## 17 POWER SUPPLY AND SIGNALS SPECIFICATIONS

Generic electrical output signals of the valve (e.g. fault or monitor signals) must not be directly used to activate safety functions, like to switch-ON/OFF the machine's safety components, as prescribed by the European standards (Safety requirements of fluid technology systems and components-hydraulics, EN-982). For certified safety options /U see tech. table **FY100**.

### 17.1 Power supply (V+ and V0)

The power supply must be appropriately stabilized or rectified and filtered: apply at least a 10000 µF/40 V capacitance to single phase rectifiers or a 4700 µF/40 V capacitance to three phase rectifiers. In case of separate power supply see 17.2.



A safety fuse is required in series to each power supply: 2,5 A time lag fuse.

### 17.2 Power supply for driver's logic and communication (VL+ and VL0) - only for /Z option and **TES-SP, SF, SL** with fieldbus

The power supply for driver's logic and communication must be appropriately stabilized or rectified and filtered: apply at least a 10000 µF/40 V capacitance to single phase rectifiers or a 4700 µF/40 V capacitance to three phase rectifiers.

The separate power supply for driver's logic on pin 9 and 10, allow to remove solenoid power supply from pin 1 and 2 maintaining active the diagnostics, USB and fieldbus communications.



A safety fuse is required in series to each driver's logic and communication power supply: 500 mA fast fuse.

### 17.3 Flow reference input signal (Q\_INPUT+)

The driver controls in closed loop the valve spool position proportionally to the external reference input signal.

Reference input signal is factory preset according to selected valve code, defaults are ±10 VDC for standard and 4 ÷ 20 mA for /I option.

Input signal can be reconfigured via software selecting between voltage and current, within a maximum range of ±10 VDC or ±20 mA.

Drivers with fieldbus interface can be software set to receive reference signal directly from the machine control unit (fieldbus reference). Analog reference input signal can be used as on-off commands with input range 0 ÷ 24VDC.

### 17.4 Pressure or force reference input signal (F\_INPUT+) - only for **TES-SP, SF, SL**

Functionality of F\_INPUT+ signal (pin 7), is used as reference for the driver pressure/force closed loop (see tech. table GS002).

Reference input signal is factory preset according to selected valve code, defaults are ±10 Vdc for standard and 4 ÷ 20 mA for /I option.

Input signal can be reconfigured via software selecting between voltage and current, within a maximum range of ±10 VDC or ±20 mA.

Drivers with fieldbus interface can be software set to receive reference signal directly by the machine control unit (fieldbus reference).

Analog reference input signal can be used as on-off commands with input range 0 ÷ 24VDC.

### 17.5 Flow monitor output signal (Q\_MONITOR) - only for standard, /Q, /Z and **TES-SP, SF, SL**

The driver generates an analog output signal proportional to the actual spool position of the valve; the monitor output signal can be software set to show other signals available in the driver (e.g. analog reference, fieldbus reference, pilot spool position).

Monitor output signal is factory preset according to selected valve code, defaults are ±10 Vdc for standard and 4 ÷ 20 mA for /I option.

Output signal can be reconfigured via software selecting between voltage and current, within a maximum range of ±10 VDC or ±20 mA.

### 17.6 Pressure or force monitor output signal (F\_MONITOR) - only for **TES-SP, SF, SL**

The driver generates an analog output signal proportional to alternated pressure/force control; the monitor output signal can be software set to show other signals available in the driver (e.g. analog reference, force reference).

Monitor output signal is factory preset according to selected valve code, defaults are ±10 Vdc for standard and 4 ÷ 20 mA for /I option.

Output signal can be reconfigured via software selecting between voltage and current, within a maximum range of ±10 VDC or ±20 mA.

**17.7 Enable input signal (ENABLE)** - only for /Q, /Z and TES-SP, SF, SL

To enable the driver, supply a 24 Vdc on pin 3 (pin C): Enable input signal allows to enable/disable the current supply to the solenoid, without removing the electrical power supply to the driver; it is used to active the communication and the other driver functions when the valve must be disabled for safety reasons. This condition **does not comply** with norms IEC 61508 and ISO 13849. Enable input signal can be used as generic digital input by software selection.

**17.8 Repeat enable output signal (R\_ENABLE)** - only for TEB with /Z option

Repeat enable is used as output repeater signal of enable input signal (see 17.7).

**17.9 Fault output signal (FAULT)** - only for /F, /Z and TES-SP, SF, SL

Fault output signal indicates fault conditions of the driver (solenoid short circuits/not connected, reference signal cable broken for 4 ÷ 20 mA input, spool position transducer cable broken, etc.). Fault presence corresponds to 0 Vdc, normal working corresponds to 24 Vdc. Fault status is not affected by the Enable input signal. Fault output signal can be used as digital output by software selection.

**17.10 Remote pressure/force transducer input signal** - only for TES-SP, SF, SL

Analog remote pressure transducers or load cell can be directly connected to the driver. Analog input signal is factory preset according to selected valve code, defaults are ±10 Vdc for standard and 4 ÷ 20 mA for /C option. Input signal can be reconfigured via software selecting between voltage and current, within a maximum range of ±10 Vdc or ± 20 mA. Refer to pressure/force transducer characteristics to select the transducer type according to specific application requirements (see tech table GS002).

**17.11 Multiple PID selection (D\_IN0 and D\_IN1)** - only NP execution for TES-SP, SF, SL

Two on-off input signals are available on the main connector to select one of the four pressure (force) PID parameters setting, stored into the driver. Switching the active setting of pressure PID during the machine cycle allows to optimize the system dynamic response in different hydraulic working conditions (volume, flow, etc.). Supply a 24 Vdc or a 0 Vdc on pin 9 and/or pin 10, to select one of the PID settings as indicated by binary code table at side. Gray code can be selected by software.

PID SET SELECTION				
PIN	SET 1	SET 2	SET 3	SET 4
9	0	24 Vdc	0	24 Vdc
10	0	0	24 Vdc	24 Vdc

**18 ELECTRONIC CONNECTIONS**

**18.1 Main connector signals - 7 pin (A1)** Standard, /Q and /F options

PIN	Standard	/Q	/F	TECHNICAL SPECIFICATIONS	NOTES
A	V+			Power supply 24 Vdc	Input - power supply
B	V0			Power supply 0 Vdc	Gnd - power supply
C	AGND		AGND	Analog ground	Gnd - analog signal
		ENABLE		Enable (24 Vdc) or disable (0 Vdc) the valve, referred to V0	Input - on/off signal
D	Q_INPUT+			Flow reference input signal: ±10 Vdc / ±20 mA maximum range Defaults are ±10 Vdc for standard and 4 ÷ 20 mA for /I option	Input - analog signal <b>Software selectable</b>
E	INPUT-			Negative reference input signal for Q_INPUT+	Input - analog signal
F	Q_MONITOR referred to: AGND	V0		Flow monitor output signal: ±10 Vdc / ±20 mA maximum range Defaults are ±10 Vdc for standard and 4 ÷ 20 mA for /I option	Output - analog signal <b>Software selectable</b>
			FAULT	Fault (0 Vdc) or normal working (24 Vdc)	Output - on/off signal
G	EARTH			Internally connected to the driver housing	

**18.2 Main connector signals - 12 pin (A2)** /Z option and TES-SP, SF, SL

PIN	TEB-SN /Z	TES-SN /Z	TES-SP, SF, SL Fieldbus	NP	TECHNICAL SPECIFICATIONS	NOTES
1	V+				Power supply 24 Vdc	Input - power supply
2	V0				Power supply 0 Vdc	Gnd - power supply
3	ENABLE referred to: V0	VLO	VLO	V0	Enable (24 Vdc) or disable (0 Vdc) the valve	Input - on/off signal
4	Q_INPUT+				Flow reference input signal: ±10 Vdc / ±20 mA maximum range Defaults are ±10 Vdc for standard and 4 ÷ 20 mA for /I option	Input - analog signal <b>Software selectable</b>
5	INPUT-				Negative reference input signal for Q_INPUT+ and F_INPUT+	Input - analog signal
6	Q_MONITOR referred to: AGND	VLO	VLO	V0	Flow monitor output signal: ±10 Vdc / ±20 mA maximum range Defaults are ±10 Vdc for standard and 4 ÷ 20 mA for /I option	Output - analog signal <b>Software selectable</b>
7	AGND				Analog ground	Gnd - analog signal
		NC			Do not connect	
			F_INPUT+		Pressure/Force reference input signal: ±10 Vdc / ±20 mA maximum range Defaults are ±10 Vdc for standard and 4 ÷ 20 mA for /I option	Input - analog signal <b>Software selectable</b>
8	R_ENABLE				Repeat enable, output repeter signal of enable input, referred to V0	Output - on/off signal
		NC			Do not connect	
			F_MONITOR referred to: VLO	V0	Pressure/Force monitor output signal: ±10 Vdc / ±20 mA maximum range Defaults are ±10 Vdc for standard and 4 ÷ 20 mA for /I option	Output - analog signal <b>Software selectable</b>
9	NC				Do not connect	
		VL+			Power supply 24 Vdc for driver's logic and communication	Input - power supply
10				D_IN0	Multiple pressure/force PID selection, referred to V0	Input - analog signal
					Do not connect	
10	NC				Do not connect	
		VLO			Power supply 0 Vdc for driver's logic and communication	Gnd - power supply
				D_IN1	Multiple pressure/force PID selection (not available for SF), referred to V0	Input - on/off signal
11	FAULT referred to: V0	VLO	VLO	VLO	Fault (0 Vdc) or normal working (24 Vdc)	Output - on/off signal
PE	EARTH				Internally connected to the driver housing	

**Note:** do not disconnect VLO before VL+ when the driver is connected to PC USB port

### 18.3 Communications connectors (B) - (C)

(B) USB connector - M12 - 5 pin always present		
PIN	SIGNAL	TECHNICAL SPECIFICATION (1)
1	+5V_USB	Power supply
2	ID	Identification
3	GND_USB	Signal zero data line
4	D-	Data line -
5	D+	Data line +

(C1) (C2) BC fieldbus execution, connector - M12 - 5 pin		
PIN	SIGNAL	TECHNICAL SPECIFICATION (1)
1	CAN_SHLD	Shield
2	not used	(C1) - (C2) pass-through connection (2)
3	CAN_GND	Signal zero data line
4	CAN_H	Bus line (high)
5	CAN_L	Bus line (low)

(C1) (C2) BP fieldbus execution, connector - M12 - 5 pin		
PIN	SIGNAL	TECHNICAL SPECIFICATION (1)
1	+5V	Termination supply signal
2	LINE-A	Bus line (high)
3	DGND	Data line and termination signal zero
4	LINE-B	Bus line (low)
5	SHIELD	

(C1) (C2) EH, EW, EI, EP fieldbus execution, connector - M12 - 4 pin		
PIN	SIGNAL	TECHNICAL SPECIFICATION (1)
1	TX+	Transmitter
2	RX+	Receiver
3	TX-	Transmitter
4	RX-	Receiver
Housing	SHIELD	

Notes: (1) shield connection on connector's housing is recommended

(2) pin 2 can be fed with external +5V supply of CAN interface

### 18.4 Remote pressure/force transducer connector - M12 - 5 pin - only for SP, SF, SL (D)

PIN	SIGNAL	TECHNICAL SPECIFICATION	NOTES	(D1) SP, SL - Single transducer (1)		(D2) SF - Double transducers (1)	
				Voltage	Current	Voltage	Current
1	VF +24V	Power supply +24Vdc	Output - power supply	Connect	Connect	Connect	Connect
2	TR1	1st signal transducer: ±10 Vdc / ±20 mA maximum range	Input - analog signal <b>Software selectable</b>	Connect	Connect	Connect	Connect
3	AGND	Common gnd for transducer power and signals	Common gnd	Connect	/	Connect	/
4	TR2	2nd signal transducer: ±10 Vdc / ±20 mA maximum range	Input - analog signal <b>Software selectable</b>	/	/	Connect	Connect
5	NC	Not connect		/	/	/	/

Note: (1) single/double transducer configuration is software selectable

### Remote pressure transducers connection - example

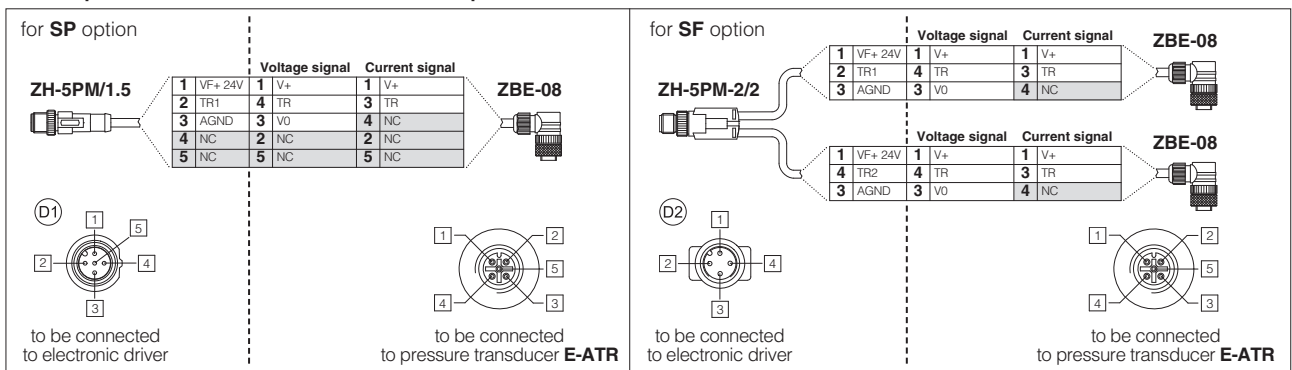

Note: pin layout always referred to driver's view

### 18.5 TEB connections layout

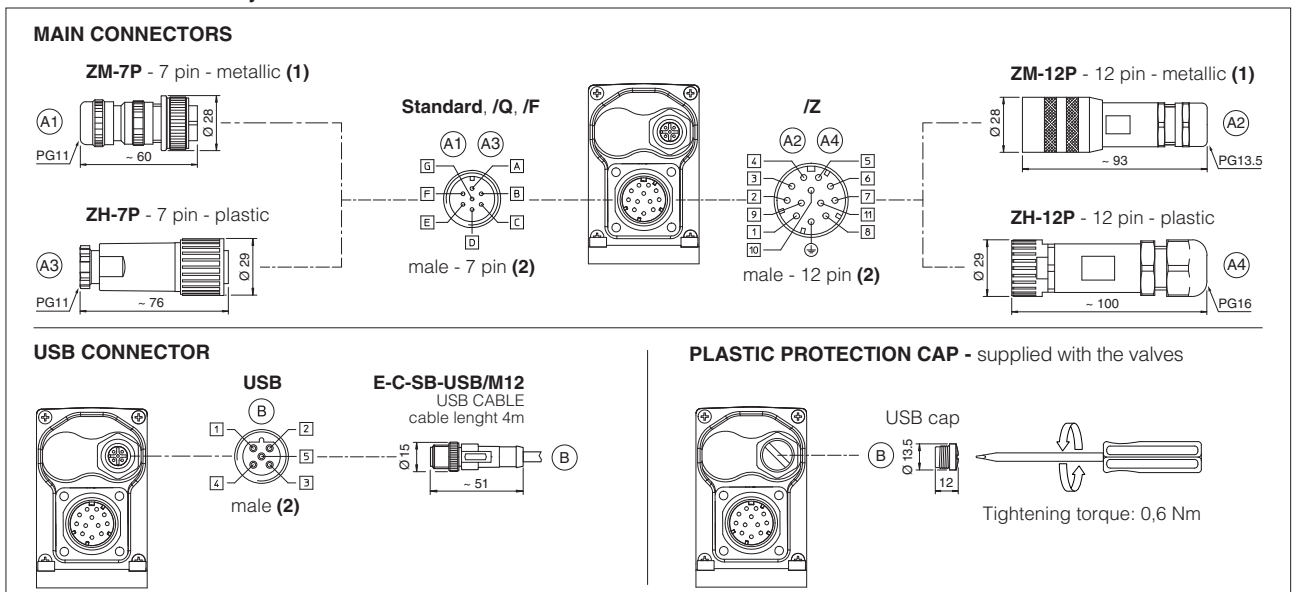

Notes: (1) use of metallic connectors is strongly recommended in order to fulfill EMC requirements

(2) pin layout always referred to driver's view



## 18.6 TES connections layout

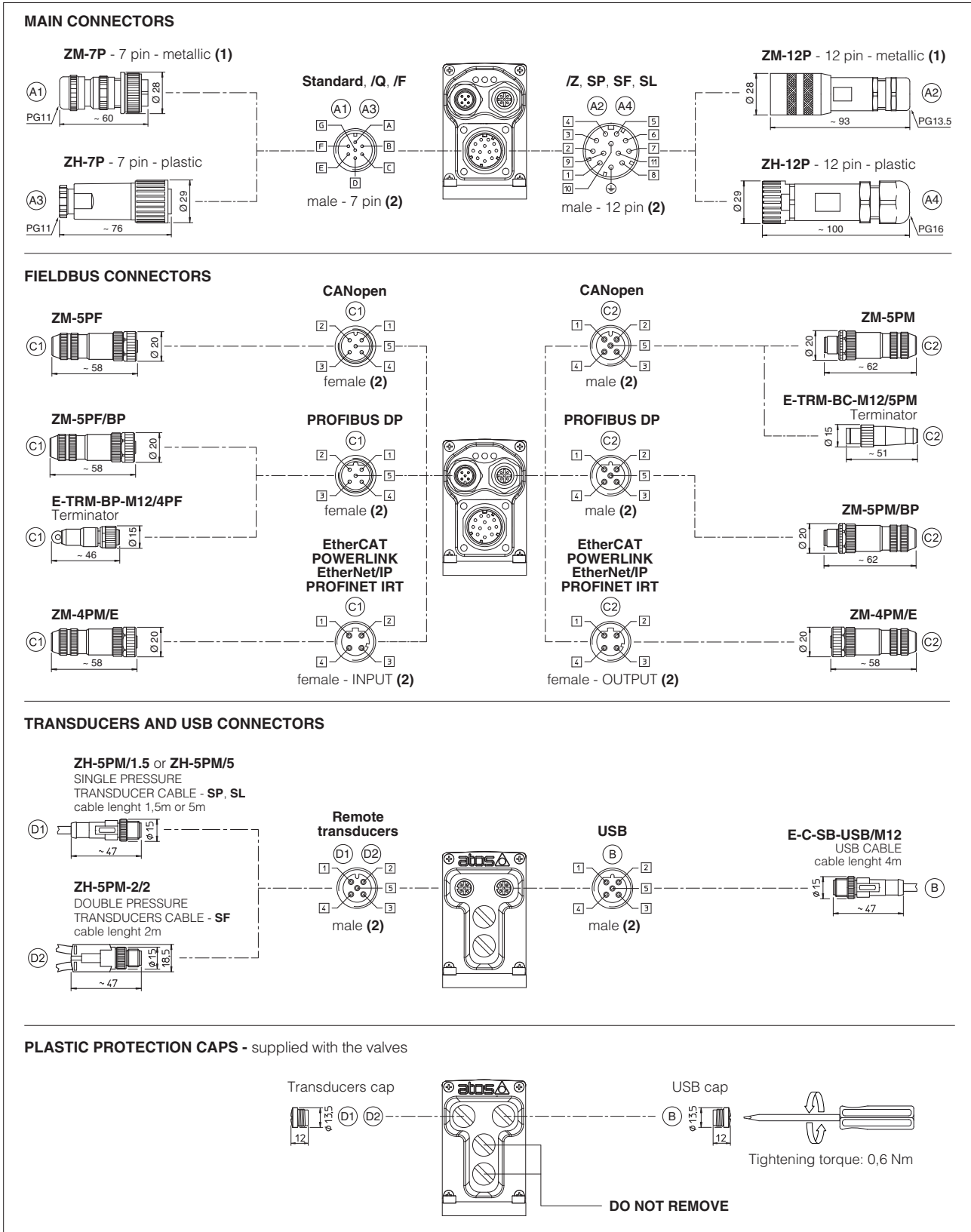

**Notes:** (1) use of metallic connectors is strongly recommended in order to fulfill EMC requirements (2) pin layout always referred to driver's view

## 18.7 Diagnostic LEDs - only for TES

Three leds show driver operative conditions for immediate basic diagnostics. Please refer to the driver user manual for detailed information.

FIELDBUS LEDS	NP Not Present	BC CANopen	BP PROFIBUS DP	EH EtherCAT	EW POWERLINK	EI EtherNet/IP	EP PROFINET IRT	L1 L2 L3
L1		VALVE STATUS			LINK/ACT			
L2		NETWORK STATUS			NETWORK STATUS			
L3		SOLENOID STATUS			LINK/ACT			

## 19 IN / OUT FIELDBUS COMMUNICATION CONNECTORS

Two fieldbus communication connectors are always available for digital drivers executions BC, BP, EH, EW, EI, EP. This features allows considerable technical advantages in terms of installation simplicity, wirings reduction and also avoid the usage expensive T-connectors.

For BC and BP executions the fieldbus connectors have an internal pass-through connection and can be used like end point of the fieldbus network, using an external terminator (see tech table **GS500**).

For EH, EW, EI and EP executions the external terminators are not required: each connector is internally terminated.

### BC and BP pass-through connection

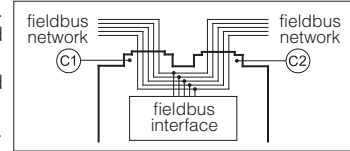

## 20 CONNECTORS CHARACTERISTICS - to be ordered separately

### 20.1 Main connectors - 7 pin

CONNECTOR TYPE	POWER SUPPLY	POWER SUPPLY
<b>CODE</b>	<b>(A1) ZM-7P</b>	<b>(A3) ZH-7P</b>
Type	7pin female straight circular	7pin female straight circular
Standard	According to MIL-C-5015	According to MIL-C-5015
Material	Metallic	Plastic reinforced with fiber glass
Cable gland	PG11	PG11
Recommended cable	LiYCY 7 x 0,75 mm <sup>2</sup> max 20 m (logic and power supply) or LiYCY 7 x 1 mm <sup>2</sup> max 40 m (logic and power supply)	LiYCY 7 x 0,75 mm <sup>2</sup> max 20 m (logic and power supply) or LiYCY 7 x 1 mm <sup>2</sup> max 40 m (logic and power supply)
Conductor size	up to 1 mm <sup>2</sup> - available for 7 wires	up to 1 mm <sup>2</sup> - available for 7 wires
Connection type	to solder	to solder
Protection (EN 60529)	IP 67	IP 67

### 20.2 Main connectors - 12 pin

CONNECTOR TYPE	POWER SUPPLY	POWER SUPPLY
<b>CODE</b>	<b>(A2) ZM-12P</b>	<b>(A4) ZH-12P</b>
Type	12pin female straight circular	12pin female straight circular
Standard	DIN 43651	DIN 43651
Material	Metallic	Plastic reinforced with fiber glass
Cable gland	PG13,5	PG16
Recommended cable	LiYCY 12 x 0,75 mm <sup>2</sup> max 20 m (logic and power supply)	LiYCY 10 x 0,14mm <sup>2</sup> max 40 m (logic) LiYY 3 x 1mm <sup>2</sup> max 40 m (power supply)
Conductor size	0,5 mm <sup>2</sup> to 1,5 mm <sup>2</sup> - available for 12 wires	0,14 mm <sup>2</sup> to 0,5 mm <sup>2</sup> - available for 9 wires 0,5 mm <sup>2</sup> to 1,5 mm <sup>2</sup> - available for 3 wires
Connection type	to crimp	to crimp
Protection (EN 60529)	IP 67	IP 67

### 20.3 Fieldbus communication connectors

CONNECTOR TYPE	BC CANopen (1)		BP PROFIBUS DP (1)		EH EtherCAT, EW POWERLINK, EI EtherNet/IP, EP PROFINET IRT (2)
<b>CODE</b>	<b>(C1) ZM-5PF</b>	<b>(C2) ZM-5PM</b>	<b>(C1) ZM-5PF/BP</b>	<b>(C2) ZM-5PM/BP</b>	<b>(C1) (C2) ZM-4PM/E</b>
Type	5 pin female straight circular	5 pin male straight circular	5 pin female straight circular	5 pin male straight circular	4 pin male straight circular
Standard	M12 coding A – IEC 61076-2-101		M12 coding B – IEC 61076-2-101		M12 coding D – IEC 61076-2-101
Material	Metallic		Metallic		Metallic
Cable gland	Pressure nut - cable diameter 6÷8 mm		Pressure nut - cable diameter 6÷8 mm		Pressure nut - cable diameter 4÷8 mm
Cable	CANbus Standard (DR 303-1)		PROFIBUS DP Standard		Ethernet standard CAT-5
Connection type	screw terminal		screw terminal		terminal block
Protection (EN 60529)	IP67		IP 67		IP 67

**Notes: (1)** E-TRM-\*\* terminators can be ordered separately - see tech table **GS500**

**(2)** Internally terminated

## 21 FASTENING BOLTS AND SEALS

	<b>DHZO</b>  <b>Fastening bolts:</b> 4 socket head screws M5x50 class 12.9 Tightening torque = 8 Nm	<b>DKZOR</b>  <b>Fastening bolts:</b> 4 socket head screws M6x40 class 12.9 Tightening torque = 15 Nm
	<b>Seals:</b> 4 OR 108; Diameter of ports A, B, P, T: Ø 7,5 mm (max) 1 OR 2025 Diameter of port Y: Ø = 3,2 mm (only for /Y option)	<b>Seals:</b> 5 OR 2050; Diameter of ports A, B, P, T: Ø 11,2 mm (max) 1 OR 108 Diameter of port Y: Ø = 5 mm (only for /Y option)

## DHZO-TEB, DHZO-TES

ISO 4401: 2000

Mounting surface: 4401-03-02-0-05 (see table P005)

(for /Y surface 4401-03-03-0-05 without X port)

Fastening bolts: 4 socket head screws M5x50 class 12.9

Tightening torque = 8 Nm

Seals: 4 OR 108; 1 OR 2025

Diameter of ports A, B, P, T:  $\varnothing$  7,5 mm (max)

Diameter of port Y:  $\varnothing$  = 3,2 mm (only for /Y option)

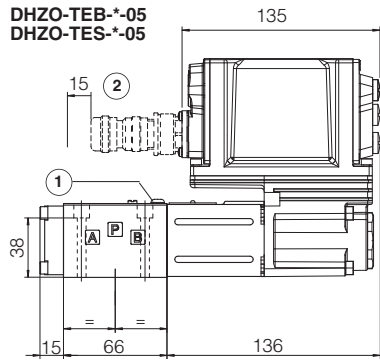

Mass: 2,3 kg

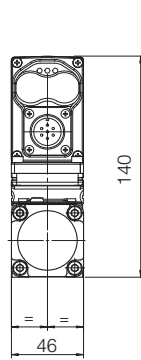

155 for SP, SF, SL, EW - POWERLINK,  
EI - EtherNet/IP, EP - PROFINET IRT

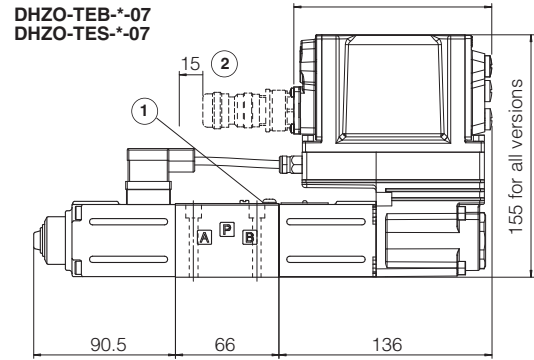

Mass: 3,1 kg

## DKZOR-TEB, DKZOR-TES

ISO 4401: 2000

Mounting surface: 4401-05-04-0-05 (see table P005)

(for /Y surface 4401-05-05-0-05 without X port)

Fastening bolts: 4 socket head screws M6x40 class 12.9

Tightening torque = 15 Nm

Seals: 5 OR 2050; 1 OR 108

Diameter of ports A, B, P, T:  $\varnothing$  11,2 mm (max)

Diameter of port Y:  $\varnothing$  = 5 mm (only for /Y option)

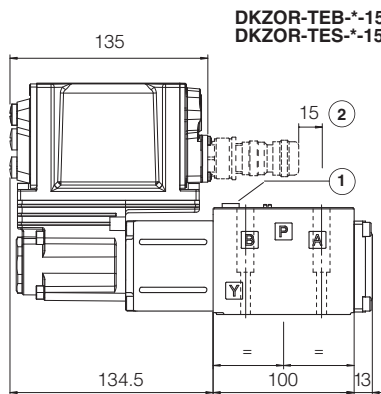

Mass: 4,3 kg

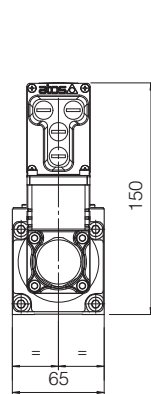

165 for SP, SF, SL, EW - POWERLINK,  
EI - EtherNet/IP, EP - PROFINET IRT

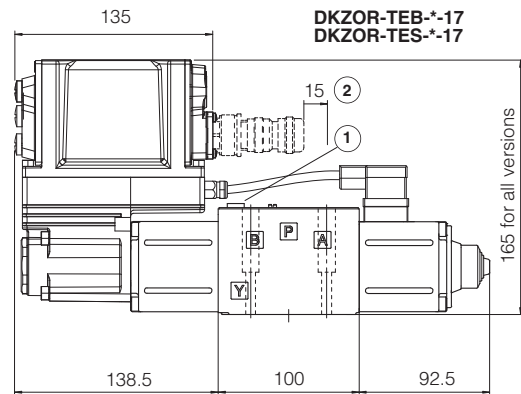

Mass: 5,0 kg

① = Air bleed off

② = Space to remove the 7 or 12 pin main connector. For main and communication connectors see section 13, 14

## 23 RELATED DOCUMENTATION

<b>F002</b>	Basics for digital electrohydraulics
<b>F003</b>	Commissioning and troubleshooting
<b>FS230</b>	Digital proportional valves with integral axis controller
<b>FY100</b>	Safety digital valves
<b>GS001</b>	Basics for digital proportionals
<b>GS002</b>	Basics for digital proportionals with P/Q control
<b>GS003</b>	Settings for digital proportionals
<b>GS500</b>	Programming tools
<b>GS510</b>	Fieldbus
<b>K500</b>	Electric and electronic connectors
<b>P005</b>	Mounting surfaces for electrohydraulic valves
<b>QB300</b>	Quickstart for TEB valves commissioning
<b>QF300</b>	Quickstart for TES valves commissioning