

Ex-proof solenoid directional valves

on-off, direct, spool type - **ATEX, IECEx, EAC, PESO** or **cULus**

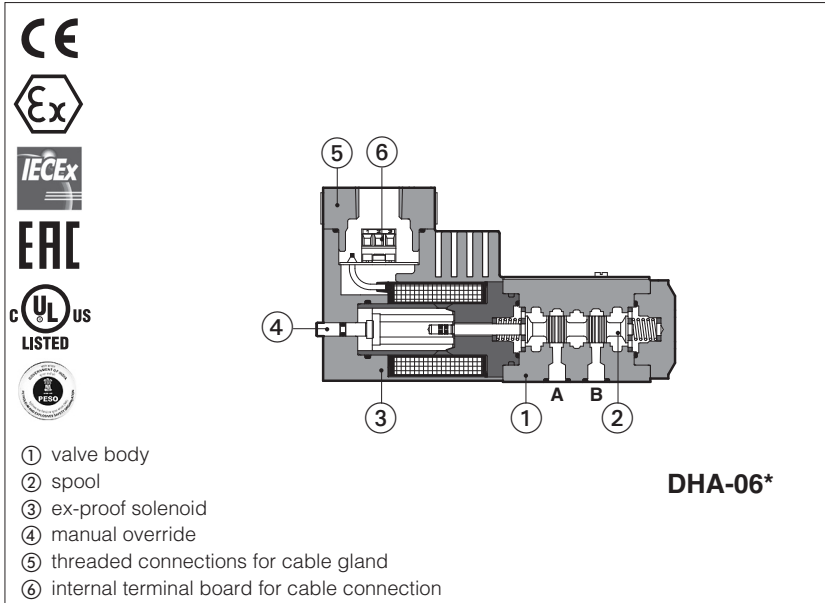

DHA

On-off, spool type directional valves equipped with ex-proof solenoids certified for safe operation in hazardous environments with potentially explosive atmosphere.

Certifications:

- Multicertification **ATEX, IECEx, EAC** and **PESO** for gas group **II 2G** and dust category **II 2D**
- Multicertification **ATEX** and **IECEx** for gas group **I M2** (mining)
- **cULus** North American certification for gas group **C&D**

DHA valves are **SIL** compliance with IEC 61508 (TÜV certified)

The flameproof enclosure of solenoid prevents the propagation of accidental internal sparks or fire to the external environment.

The solenoid is also designed to limit the surface temperature within the classified limits.

Size: **06** - ISO 4401

Max flow: **70 l/min**

Max pressure: **350 bar**

1 MODEL CODE

DHA	-	*	/	0	63	/	1/2	/	M	/	*	24DC	/	**	/	*
<p>Ex-proof solenoid directional valve, direct, spool type</p> <p>Certification type: Multicertification ATEX, IECEx, EAC: - = omit for Group II 2G / II 2D (1) M = Group I M2 (mining) North American Certification: UL = cULus</p> <p>Valve size (ISO 4401) 0 = 06</p> <p>Configuration, see section 2 :</p> <p>Spool type, see section 2 :</p>																
<p>Seals material, see section 6 :</p> <p>- = NBR PE = FKM BT = HNBR (1)</p> <p>Series number _____</p> <p>Voltage code, see section 5</p> <p>Options (3): A = solenoid at side of port B (for single solenoid valves) O = horizontal cable entrance (2) WP = manual override protected by metallic cap Hand lever options (4): MV = vertical hand lever AMV = vertical hand lever installed at side of port B</p> <p>Solenoid threaded connection for cable gland fitting: GK = GK-1/2" - not for cULus (5) M = M20x1,5 - not for cULus NPT = 1/2" NPT</p>																

- (1)** The valves with Multicertification for Group II are also certified for Indian market according to **PESO** (Petroleum and Explosives Safety Organization). The PESO certificate can be downloaded from www.atos.com
- (2)** Not for multicertification **M** group I (mining)
- (3)** For possible combined options, see 11.1
- (4)** Options MV and AMV are available only for configuration **61, 61/A, 63, 63/A, 71** and with spool type **0, 0/2, 1, 1P, 1/2, 1/2P, 3, 3P, 4, 7**.
Not available in combination with option **WP**
- (5)** Approved only for the Italian market

The pressure at T port makes difficult the manual override operation that can be possible only if its value is lower than 50 bar

2 CONFIGURATIONS AND SPOOLS (representation according to ISO 1219-1)

Configurations	Spoils	Configurations	Spoils
<p>61</p>	<p>1 0 2</p>	<p>63</p>	<p>1 0 2</p>
<p>61/A</p>	<p>0 2</p>	<p>63/A</p>	<p>0/2</p>
<p>67</p>	<p>4 5 6 7</p>	<p>70</p>	<p>1/2</p>
<p>67/A</p>	<p>8 90 09 91</p>	<p>75</p>	<p>2/2 (1)</p>
<p>71</p>	<p>19 93 39 94</p>		
	<p>49 16 17 58</p>		

For spool type 2 and 2/2 port T of the valve must be connected to tank if the operating pressure exceed the max T pressure reported at section **4**
(1): not available for configuration 75

2.1 Special shaped spoils

- spoils type **0** and **3** are also available as **0/1** and **3/1** with restricted oil passages in central position, from user ports to tank.
- spoils type **1**, **4**, **5** and **58** are also available as **1/1**, **4/8**, **5/1** and **58/1**. They are properly shaped to reduce water-hammer shocks during the swiching.
- spoils type **1**, **1/2**, **3**, **8** are available as **1P**, **1/2P**, **3P**, **8P** to limit valve internal leakages.

3 GENERAL CHARACTERISTICS

Assembly position / location	Any position
Subplate surface finishing to ISO 4401	Acceptable roughness index, Ra ≤0,8 recommended Ra 0,4 - flatness ratio 0,01/100
MTTFd values according to EN ISO 13849	150 years, for further details see technical table P007
Ambient temperature	Standard = -20°C ÷ +70°C /PE option = -20°C ÷ +70°C /BT option = -40°C ÷ +70°C
Storage temperature range	Standard = -20°C ÷ +80°C /PE option = -20°C ÷ +80°C /BT option = -40°C ÷ +70°C
Surface protection	Zinc coating with black passivation - salt spray test (EN ISO 9227) > 200h
Compliance	Explosion proof protection, see section 7 -Flame proof enclosure "Ex d" -Dust ignition protection by enclosure "Ex t" RoHs Directive 2011/65/EU as last update by 2015/65/EU REACH Regulation (EC) n°1907/2006

4 HYDRAULIC CHARACTERISTICS

Operating pressure	Ports P,A,B: 350 bar; Port T 210 bar
Rated flow	See diagrams Q/Δp at section 12
Maximum flow	70 l/min , see operating limits at section 13

5 ELECTRICAL CHARACTERISTICS

Valve type	DHA	DHA/M	DHA/UL
Voltage code (1) Vdc ±10%	12DC, 24DC, 28DC, 48DC, 110DC, 125DC, 220DC		12DC, 24DC, 110DC, 125DC, 220DC
VAC 50/60 Hz ±10%	12AC, 24AC, 110AC, 230AC		12AC, 24AC, 110AC, 230AC
Power consumption at 20°C	8W		12W
Coil insulation	class H		
Protection degree with relevant cable gland	IP66/67 to DIN EN60529		raintight enclosure, UL approved
Duty factor	100%		

- (1) For alternating current supply a rectifier bridge is provided built-in the solenoid
For power supply frequency 60 Hz, the nominal supply voltage of solenoids 110AC and 230AC must be 115/60 and 240/60 respectively

6 SEALS AND HYDRAULIC FLUIDS - for other fluids not included in below table, consult our technical office

Seals, recommended fluid temperature	NBR seals (standard) = -20°C ÷ +60°C, with HFC hydraulic fluids = -20°C ÷ +50°C FKM seals (/PE option) = -20°C ÷ +80°C HNBR seals (/BT option) = -40°C ÷ +60°C, with HFC hydraulic fluids = -40°C ÷ +50°C		
Recommended viscosity	15 ÷ 100 mm ² /s - max allowed range 2.8 ÷ 500 mm ² /s		
Max fluid contamination level	ISO4406 class 20/18/15 NAS1638 class 9, see also filter section at www.atos.com or KTF catalog		
Hydraulic fluid	Suitable seals type	Classification	Ref. Standard
Mineral oils	NBR, FKM, HNBR	HL, HLP, HLPD, HVLP, HVLPD	DIN 51524
Flame resistant without water	FKM	HF DU, HF DR	ISO 12922
Flame resistant with water	NBR, HNBR	HFC	

⚠ The ignition temperature of the hydraulic fluid must be 50°C higher than the max solenoid surface temperature.

(1) Performance limitations in case of flame resistant fluids with water:

- max operating pressure = 210 bar
- max fluid temperature = 50°C

7 CERTIFICATION DATA

Valve type	DHA		DHA/M	DHA/UL	
Certifications	Multicertification Group II ATEX IECEx EAC PESO		Multicertification Group I ATEX IECEx	North American cULus cULus	
Solenoid certified code	OA		OA/M	OA/EC	
Type examination certificate (1)	ATEX: CESI 02 ATEX 014 IECEX: IECEx CES 10.0010x EAC: TC RU C-IT. 08.B.01784 PESO: P338131		ATEX: CESI 03 ATEX 057x IECEX: IECEx CES 12.0007x	20170324 - E366100	
Method of protection	<ul style="list-style-type: none"> • ATEX, EAC Ex II 2G Ex d IIC T6/T4/T3 Gb Ex II 2D Ex tb IIIC T85°C/T200°C Db • IECEx Ex d IIC T6/T4/T3 Gb Ex tb IIIC T85°C/T200°C Db • PESO Ex II 2G Ex d IIC T6/T4 Gb 		<ul style="list-style-type: none"> • ATEX Ex I M2 Ex db I Mb • IECEx Ex db I Mb 	<ul style="list-style-type: none"> • UL 1203 Class I, Div.I, Groups C & D Class I, Zone I, Groups IIA & IIB 	
Temperature class	T6	T4	-	T6	T5
Surface temperature	≤ 85 °C	≤ 135 °C	≤ 150 °C	≤ 85 °C	≤ 100 °C
Ambient temperature (2)	-40 ÷ +45 °C	-40 ÷ +70 °C	-20 ÷ +70 °C	-40 ÷ +55 °C	-40 ÷ +70 °C
Applicable standards	EN 60079-0: 2012+A11:2013 EN 60079-1:2014 EN 60079-31:2014		IEC 60079-0:2017 IEC 60079-1:2017-04 IEC 60079-31:2013	UL 1203 and UL429, CSA 22.2 n°30-1986 CSA 22.2 n°139-13	
Cable entrance: threaded connection vertical (standard) or horizontal (option /O)	GK = GK-1/2" M = M20x1,5 NPT = 1/2" NPT			1/2" NPT ANSI/ASME B46.1	

(1) The type examiner certificates can be downloaded from www.atos.com

(2) The solenoids **Group II** and **cULus** are certified for minimum ambient temperature -40°C
In case the complete valve must withstand with minimum ambient temperature of -40°C, select **/BT** in the model code

⚠ **WARNING: service work performed on the valve by the end users or not qualified personnel invalidates the certification**

8 EX PROOF SOLENOIDS WIRING

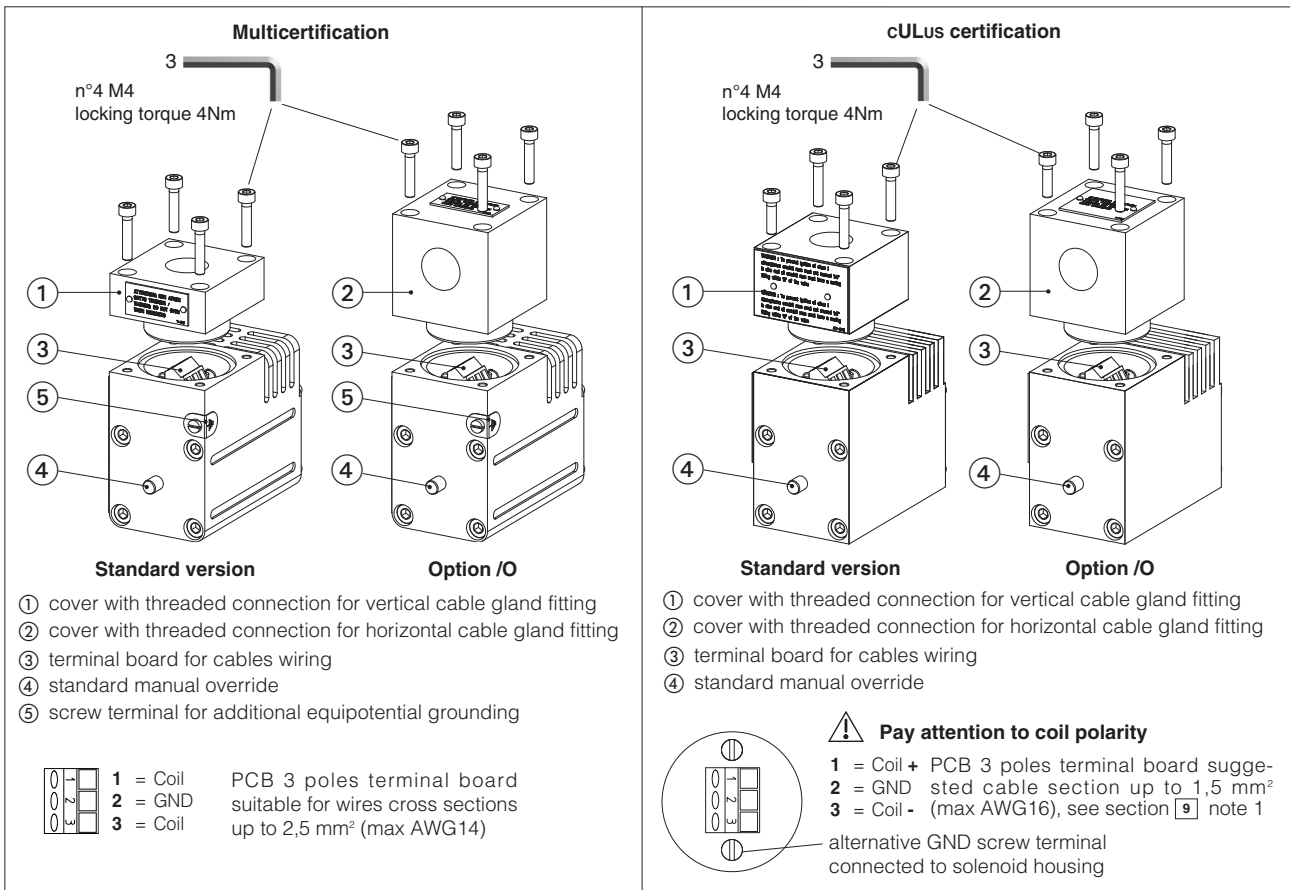

9 CABLE SPECIFICATION AND TEMPERATURE - Power supply and grounding cables have to comply with following characteristics:

Multicertification Group I and Group II	
Power supply: section of coil connection wires = 2,5 mm ²	Grounding: section of internal ground wire = 2,5 mm ² section of external ground wire = 4 mm ²
cULus certification:	
<ul style="list-style-type: none"> Suitable for use in Class I Division 1, Gas Groups C Armored Marine Shipboard Cable which meets UL 1309 Tinned Stranded Copper Conductors Bronze braided armor Overall impervious sheath over the armor 	
Any Listed (UBVZ/UBVZ7) Marine Shipboard Cable rated 300 V min, 15A min. 3C 2,5 mm ² (14 AWG) having a suitable service temperature range of at least -25°C to +110°C ("BT" Models require a temperature range from -40°C to +110°C)	
Note 1: For Class I wiring the 3C 1,5 mm ² AWG 16 cable size is admitted only if a fuse lower than 10 A is connected to the load side of the solenoid wiring.	

9.1 Cable temperature

The cable must be suitable for the working temperature as specified in the "safety instructions" delivered with the first supply of the products.

Multicertification

Max ambient temperature [°C]	Temperature class		Max surface temperature [°C]		Min cable temperature
	Group I	Group II	Group I	Group II	
45 °C	-	T6	150 °C	85 °C	not prescribed
70 °C	-	T4	150 °C	135 °C	90 °C

cULus certification

Max ambient temperature [°C]	Temperature class	Max surface temperature [°C]	Min cable temperature
55 °C	T6	85 °C	100 °C
70 °C	T5	100 °C	100 °C

10 CABLE GLANDS only for Multicertification

Cable glands with threaded connections GK-1/2", 1/2"NPT or M20x1,5 for standard or armoured cables have to be ordered separately, see tech. table **KX800**

Note: a Loctite sealant type 545, should be used on the cable gland entry threads

11 OPTIONS

- A** = solenoid at side of port B (for single solenoid valves)
O = Horizontal cable entrance, to be selected in case of limited vertical space
WP = Manual override protected by metallic cap

Hand lever option:

MV = Auxiliary vertical hand levers

This option allows to operate the valves in absence of electrical power supply, i.e. during commissioning, maintenance or in case of emergency.

When the valve is electrically operated the hand lever remains stopped in its rest position

The hand lever execution does not affect the performances of the original valves

Total angle stroke	[°deg]	± 28°	Lever actuating force	[N]	1 ÷ 8
Working angle stroke	[°deg]	± 15°	Lever device weight	[g]	880

AMV= Vertical hand lever installed at side of port B

Notes:

Options **MV** and **AMV** are available only for configuration **61, 61/A, 63, 63/A, 71** and with spool type **0, 0/2, 1, 1P, 1/2, 1/2P, 3, 3P, 4, 7**

Not available in combination with option **WP**

MV option and **AMV** allow to operate the valve in absence of electrical power supply.

For detailed description of DHA with hand lever option see tech. table **E138**

11.1 Possible combined options: /AO, /AWP, /OWP, /AMV, /OMV, /AOWP, /AOMV

12 Q/Δp DIAGRAMS (based on mineral oil ISO VG 46 at 50°C)

Flow direction Spool type	Flow direction				
	P→A	P→B	A→T	B→T	P→T
0, 0/1	A	A	C	C	D
1, 1/1	D	C	C	C	
3, 3/1	D	D	A	A	
4, 4/8, 5, 5/1, 49, 58, 58/1, 94	F	F	G	C	E
1/2, 0/2	D	D	D	D	
6, 7, 16, 17	D	D	D	D	
8	A	A	E	E	
2	D	D			
2/2	F	F			
09, 19, 90, 91	E	E	D	D	
39, 93	F	F	G	G	

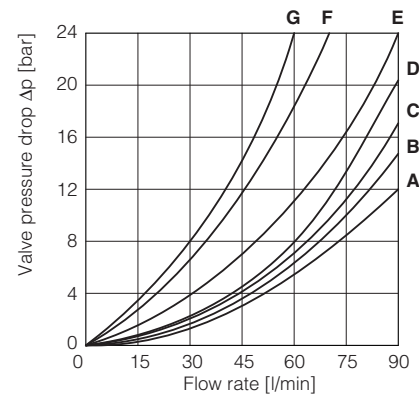

13 OPERATING LIMITS (based on mineral oil ISO VG 46 at 50°C)

Spool type	diagram
0, 0/1, 1, 1/1, 8	A
0/2, 1/2, 3, 6, 7	B
3/1, 4, 4/8, 5, 5/1, 16, 17, 19, 39, 49, 58, 58/1, 09, 90, 91, 93, 94	C

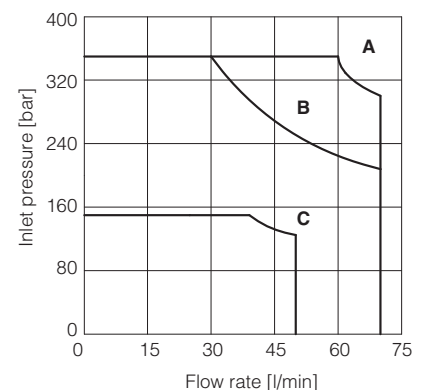

14 INSTALLATION DIMENSIONS [mm] - Multicertified and UL

ISO 4401: 2005 (see table P005)

Mounting surface: 4401-03-02-0-05

Fastening bolts: 4 socket head screws:

M5x50 class 12.9

Tightening torque = 8 Nm

Seals: 4 OR 108

Ports P,A,B,T: $\varnothing = 7.5$ mm (max)

Valve's bottom view

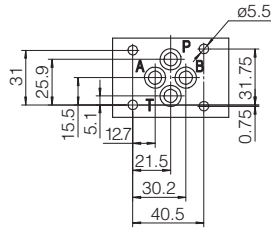

P = PRESSURE PORT
 A, B = USE PORT
 T = TANK PORT

Mass [kg]	
DHA-06	2,65
DHA-07	4,3
Option /O	+0,35
Option /WP	+0,25

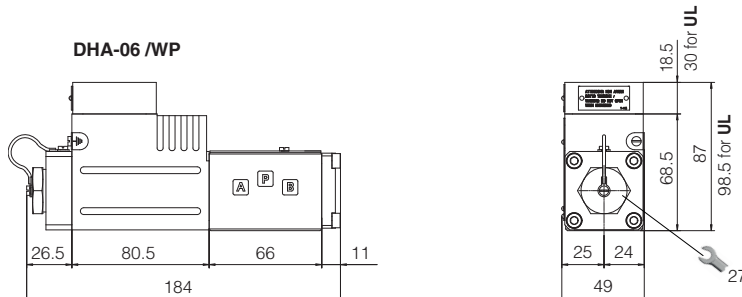
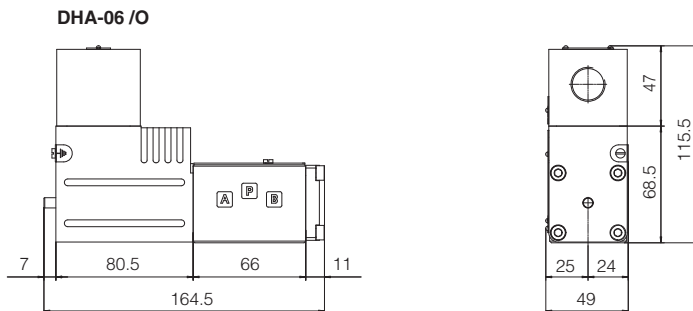
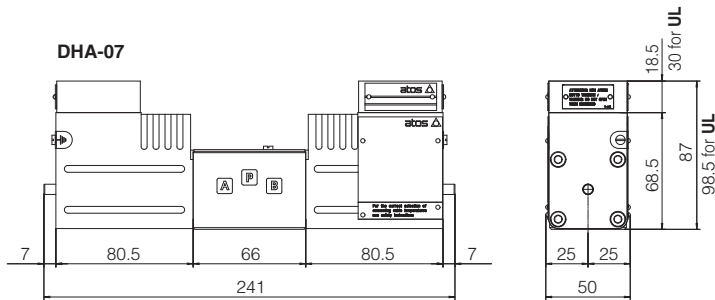
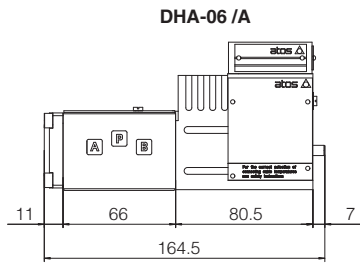
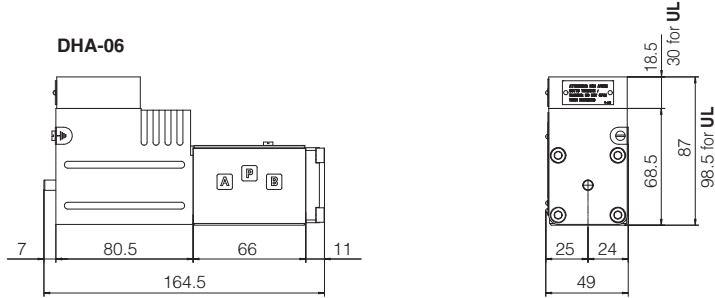

ISO 4401: 2005 (see table P005)

Mounting surface: 4401-03-02-0-05

Fastening bolts: 4 socket head screws:

M5x30 class 12.9

Tightening torque = 8 Nm

Seals: 4 OR 108

Ports P,A,B,T: $\varnothing = 7.5$ mm (max)

Valve's bottom view

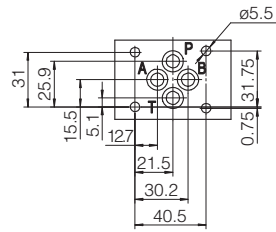

P = PRESSURE PORT
A, B = USE PORT
T = TANK PORT

Mass [kg]	
DHA-06/MV	2,9
DHA-07/MV	4,55

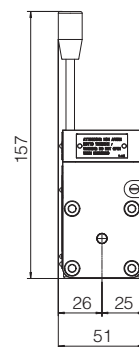
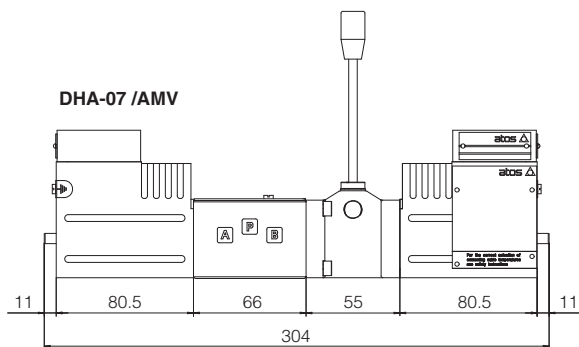
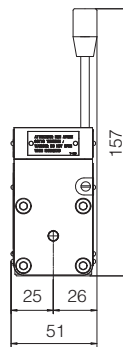
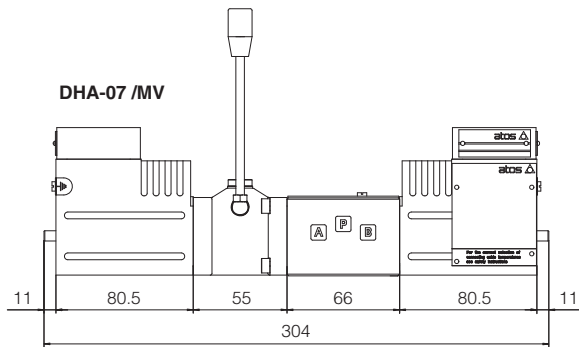
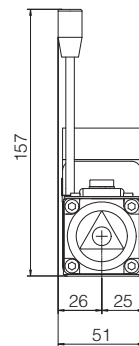
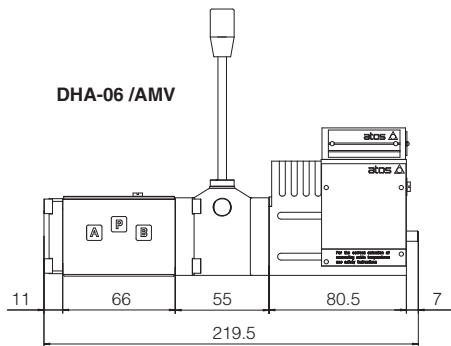
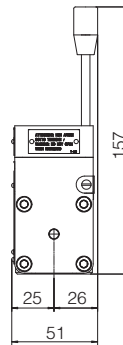
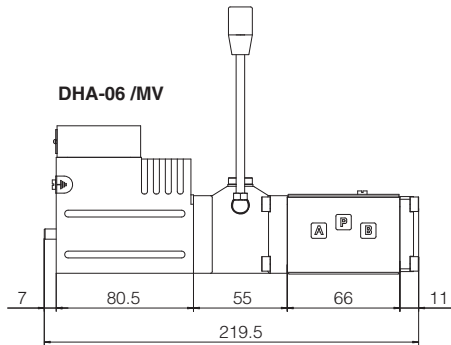

15 RELATED DOCUMENTATION

- X010** Basics for electrohydraulics in hazardous environments
- X020** Summary of Atos ex-proof components certified to ATEX, IECEx, EAC, PESO
- X030** Summary of Atos ex-proof components certified to cULus

- EX900** Operating and maintenance information for ex-proof on-off valves
- KX800** Cable glands for ex-proof valves
- P005** Mounting surfaces for electrohydraulic valves