

Ex-proof solenoid directional valves

on-off, direct, poppet type leak free - **ATEX, IECEx, EAC, PESO** or **cULus**

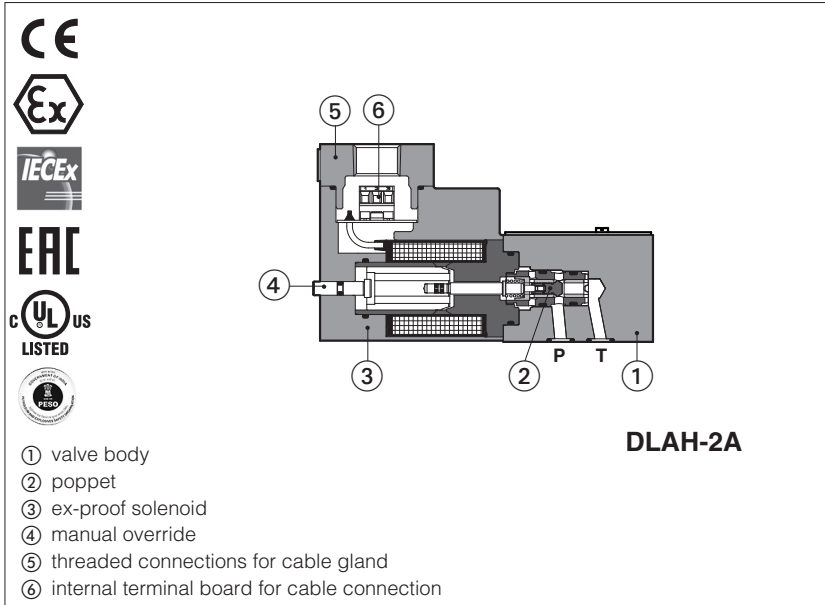

DLAH, DLAHM, CART LAH, CART LAHM
On-off poppet type, directional valves equipped with ex-proof solenoids certified for safe operation in hazardous environments with potentially explosive atmosphere.

- Certifications:
- Multicertification **ATEX, IECEx, EAC** and **PESO** for gas group **II 2G** and dust category **II 2D**
 - Multicertification **ATEX** and **IECEx** for gas group **I M2** (mining)
 - **cULus** North American certification for gas group **C&D**

They are **SIL** compliance with IEC 61508 (TÜV certified)

The flameproof enclosure of solenoid prevents the propagation of accidental internal sparks or fire to the external environment. The solenoid is also designed to limit the surface temperature within the classified limits.

DLAH subplate, **CART LAH** screw-in
Size: **06** - ISO 4401 (only for DLAH)
Max flow: **12 l/min**
Max pressure: **350 bar**

DLAHM subplate, **CART LAHM** screw-in
Size: **06** - ISO 4401 (only for DLAHM)
Max flow: **30 l/min**
Max pressure: **315 bar**

1 MODEL CODE

DLAH	/	*	-	2		A	/	M	/	*		24DC	/	**	/	*
<p>Ex-proof solenoid directional valves, poppet type</p> <p>Subplate mounting DLAH = max flow 12 l/min DLAHM = max flow 30 l/min</p> <p>Screw-in mounting CART LAH = max flow 12 l/min CART LAHM = max flow 30 l/min</p> <p>Certification type: Multicertification ATEX, IECEx, EAC, PESO: - = omit for Group II 2G / II 2D (1) M = Group I M2 (mining) North American Certification: UL = cULus</p> <p>2 = two way (only for DLAH and CART LAH) 3 = three way</p> <p>Configuration, see section 2</p> <p>A C</p>																
<p>Seals material, see section 6:</p> <p>- = NBR PE = FKM BT = HNBR (1)</p> <p>Series number</p> <p>Voltage code, see section 5</p>																
<p>Options (3):</p> <p>O = horizontal cable entrance (2) R = with check valve on port P (only for DLAH) WP = manual override protected by metallic cap</p>																
<p>Solenoid threaded connection for cable gland fitting:</p> <p>GK = GK-1/2" - not for cULus (4) M = M20x1,5 - not for cULus NPT = 1/2" NPT</p>																

(1) The valves with Multicertification for Group II are also certified for Indian market according to **PESO** (Petroleum and Explosives Safety Organization). The PESO certificate can be downloaded from www.atos.com

(2) Not for multicertification **M** group I (mining) **(3)** For possible combined options, see 12.1 **(4)** Approved only for the Italian market

The pressure at T port makes difficult the manual override operation that can be possible only if its value is lower than 50 bar

2 CONFIGURATIONS AND HYDRAULIC SYMBOLS (representation according to ISO 1219-1)

<p>DLAH-2A CART LAH-2A</p>	<p>DLAH-2A/R</p>	<p>DLAH-2C CART LAH-2C</p>	<p>DLAH-2C/R</p>	<p>DLAHM-3A CART LAHM-3A</p>
<p>DLAH-3A CART LAH-3A</p>	<p>DLAH-3A/R</p>	<p>DLAH-3C CART LAH-3C</p>	<p>DLAH-3C/R</p>	<p>DLAHM-3C CART LAHM-3C</p>

3 GENERAL CHARACTERISTICS

Assembly position / location	Any position
Subplate surface finishing to ISO 4401	Acceptable roughness index, Ra ≤0,8 recommended Ra 0,4 - flatness ratio 0,01/100
MTTFd values according to EN ISO 13849	150 years, for further details see technical table P007
Ambient temperature	Standard = -20°C ÷ +70°C /PE option = -20°C ÷ +70°C /BT option = -40°C ÷ +70°C
Storage temperature range	Standard = -20°C ÷ +80°C /PE option = -20°C ÷ +80°C /BT option = -40°C ÷ +70°C
Surface protection	Zinc coating with black passivation - salt spray test (EN ISO 9227) > 200h
Compliance	Explosion proof protection, see section 7 -Flame proof enclosure "Ex d" -Dust ignition protection by enclosure "Ex t" RoHs Directive 2011/65/EU as last update by 2015/65/EU REACH Regulation (EC) n°1907/2006

4 HYDRAULIC CHARACTERISTICS

Operating pressure	DLAH, CART LAH, ports P,A,B: 350 bar; DLAHM, CART LAHM ports P,A: 315 bar; Port T 210 bar
Rated flow	See diagrams Q/Δp at section 13
Maximum flow	DLAH, CART LAH: 12 l/min , DLAHM, CART LAHM: 30 l/min , see operating limits at section 14

5 ELECTRICAL CHARACTERISTICS

Valve type	DLAH, DLAHM CART LAH, LAHM	DLAH/M, DLAHM/M CART LAH/M, LAHM/M	DLAH/UL, DLAHM/UL CART LAH/UL, LAHM/UL
Voltage code (1) VDC ±10%	12DC, 24DC, 28DC, 48DC, 110DC, 125DC, 220DC		12DC, 24DC, 110DC, 125DC, 220DC
VAC 50/60 Hz ±10%	12AC, 24AC, 110AC, 230AC		12AC, 24AC, 110AC, 230AC
Power consumption at 20°C	8W		12W
Coil insulation	class H		
Protection degree with relevant cable gland	IP66/67 to DIN EN60529		raintight enclosure, UL approved
Duty factor	100%		

(1) For alternating current supply a rectifier bridge is provided built-in the solenoid
For power supply frequency 60 Hz, the nominal supply voltage of solenoids 110AC and 230AC must be 115/60 and 240/60 respectively

6 SEALS AND HYDRAULIC FLUIDS - for other fluids not included in below table, consult our technical office

Seals, recommended fluid temperature	NBR seals (standard) = -20°C ÷ +60°C, with HFC hydraulic fluids = -20°C ÷ +50°C FKM seals (/PE option) = -20°C ÷ +80°C HNBR seals (/BT option) = -40°C ÷ +60°C, with HFC hydraulic fluids = -40°C ÷ +50°C		
Recommended viscosity	15 ÷ 100 mm ² /s - max allowed range 2.8 ÷ 500 mm ² /s		
Max fluid contamination level	ISO4406 class 20/18/15 NAS1638 class 9, see also filter section at www.atos.com or KTF catalog		
Hydraulic fluid	Suitable seals type	Classification	Ref. Standard
Mineral oils	NBR, FKM, HNBR	HL, HLP, HLPD, HVL, HLPD	DIN 51524
Flame resistant without water	FKM	HFDR, HFDR	ISO 12922
Flame resistant with water	NBR, HNBR	HFC	

 The ignition temperature of the hydraulic fluid must be 50°C higher than the max solenoid surface temperature.

(1) Performance limitations in case of flame resistant fluids with water:

- max operating pressure = 210 bar
- max fluid temperature = 50°C

7 CERTIFICATION DATA

Valve type	DLAH, DLAHM CART LAH, LAHM		DLAH/M, DLAHM/M CART LAH/M, LAHM/M	DLAH/UL, DLAHM/UL CART LAH/UL, LAHM/UL
Certifications	Multicertification Group II ATEX IECEX EAC PESO		Multicertification Group I ATEX IECEX	North American cULus cULus
Solenoid certified code	OA		OA/M	OA/EC
Type examination certificate (1)	ATEX: CESI 02 ATEX 014 IECEX: IECEX CES 10.0010x EAC: TC RU C-IT. 08.B.01784 PESO: P338131		ATEX: CESI 03 ATEX 057x IECEX: IECEX CES 12.0007x	20170324 - E366100
Method of protection	<ul style="list-style-type: none"> • ATEX, EAC Ex II 2G Ex d IIC T6/T4/T3 Gb Ex II 2D Ex tb IIIC T85°C/T200°C Db • IECEX Ex d IIC T6/T4/T3 Gb Ex tb IIIC T85°C/T200°C Db • PESO Ex II 2G Ex d IIC T6/T4 Gb 		<ul style="list-style-type: none"> • ATEX Ex I M2 Ex db I Mb • IECEX Ex db I Mb 	<ul style="list-style-type: none"> • UL 1203 Class I, Div. I, Groups C & D Class I, Zone I, Groups IIA & IIB
Temperature class	T6	T4	-	T6 T5
Surface temperature	≤ 85 °C	≤ 135 °C	≤ 150 °C	≤ 85 °C ≤ 100 °C
Ambient temperature (2)	-40 ÷ +45 °C	-40 ÷ +70 °C	-20 ÷ +70 °C	-40 ÷ +55 °C -40 ÷ +70 °C
Applicable standards	EN 60079-0: 2012+A11:2013 EN 60079-1:2014 EN 60079-31:2014		IEC 60079-0:2017 IEC 60079-1:2017-04 IEC 60079-31:2013	UL 1203 and UL429, CSA 22.2 n°30-1986 CSA 22.2 n°139-13
Cable entrance: threaded connection vertical (standard) or horizontal (option /O)	GK = GK-1/2" M = M20x1,5 NPT = 1/2" NPT		1/2" NPT ANSI/ASME B46.1	

(1) The type examiner certificates can be downloaded from www.atos.com

(2) The solenoids **Group II** and **cULus** are certified for minimum ambient temperature -40°C

In case the complete valve must withstand with minimum ambient temperature of -40°C, select **/BT** in the model code

⚠ WARNING: service work performed on the valve by the end users or not qualified personnel invalidates the certification

8 SIL compliance with IEC 61508: 2010 - only subplate version DLAH and DLAHM

DLAH and DLAHM (multicertified for surface and mining) meets the requirements of:

- **SC3** (systematic capability)
- max **SIL 2** (HFT = 0 if the hydraulic system does not provide the redundancy for the specific safety function where the component is applied)
- max **SIL 3** (HFT = 1 if the hydraulic system provides the redundancy for the specific safety function where the component is applied)

9 EX PROOF SOLENOIDS WIRING

Multicertification

Standard version **Option /O**

① cover with threaded connection for vertical cable gland fitting
 ② cover with threaded connection for horizontal cable gland fitting
 ③ terminal board for cables wiring
 ④ standard manual override
 ⑤ screw terminal for additional equipotential grounding

1 = Coil PCB 3 poles terminal board
2 = GND suitable for wires cross sections
3 = Coil up to 2,5 mm² (max AWG14)

cULus certification

Standard version **Option /O**

① cover with threaded connection for vertical cable gland fitting
 ② cover with threaded connection for horizontal cable gland fitting
 ③ terminal board for cables wiring
 ④ standard manual override

⚠ Pay attention to coil polarity

1 = Coil + PCB 3 poles terminal board
2 = GND suggested cable section up to 1,5 mm²
3 = Coil - (max AWG16), see section 10 note 1

alternative GND screw terminal connected to solenoid housing

10 CABLE SPECIFICATION AND TEMPERATURE - Power supply and grounding cables have to comply with following characteristics:

Multicertification Group I and Group II	
Power supply: section of coil connection wires = 2,5 mm ²	Grounding: section of internal ground wire = 2,5 mm ² section of external ground wire = 4 mm ²
cULus certification:	
<ul style="list-style-type: none"> Suitable for use in Class I Division 1, Gas Groups C Armored Marine Shipboard Cable which meets UL 1309 Tinned Stranded Copper Conductors Bronze braided armor Overall impervious sheath over the armor 	
Any Listed (UBVZ/UBVZ7) Marine Shipboard Cable rated 300 V min, 15A min. 3C 2,5 mm ² (14 AWG) having a suitable service temperature range of at least -25°C to +110°C ("BT" Models require a temperature range from -40°C to +110°C)	
Note 1: For Class I wiring the 3C 1,5 mm ² AWG 16 cable size is admitted only if a fuse lower than 10 A is connected to the load side of the solenoid wiring.	

10.1 Cable temperature

The cable must be suitable for the working temperature as specified in the "safety instructions" delivered with the first supply of the products.

Multicertification

Max ambient temperature [°C]	Temperature class		Max surface temperature [°C]		Min cable temperature
	Group I	Group II	Group I	Group II	
45 °C	-	T6	150 °C	85 °C	not prescribed
70 °C	-	T4	150 °C	135 °C	90 °C

cULus

Max ambient temperature [°C]	Temperature class	Max surface temperature [°C]	Min cable temperature
55 °C	T6	85 °C	100 °C
70 °C	T5	100 °C	100 °C

11 CABLE GLANDS only for Multicertification

Cable glands with threaded connections GK-1/2", 1/2"NPT or M20x1,5 for standard or armoured cables have to be ordered separately, see tech. table **KX800**

Note: a Loctite sealant type 545, should be used on the cable gland entry threads

12 OPTIONS

O = Horizontal cable entrance, to be selected in case of limited vertical space

R = Only for DLAH: integral check valve for free reverse flow

The DLAH-*/R are provided with integral check valve for free reverse flow A→B

WP = Manual override protect by metallic cap

12.1 Possible combined options: /OP, /OR, /PR, /OPR

13 Q/Δp DIAGRAMS (based on mineral oil ISO VG 46 at 50°C)

Flow direction	P → A (1) (P → B)	A → T (B → T)
Valve type		
DLAH-2A CART LAH-2A	B	-
DLAH-2C CART LAH-2C	C	-
DLAH-3A CART LAH-3A	D	C
DLAH-3C CART LAH-3C	C	A
DLAHM-3A CART LAHM-3A	F	E
DLAHM-3C CART LAHM-3C	F	E

(1) For two-way valves, pressure drop refers to P→T

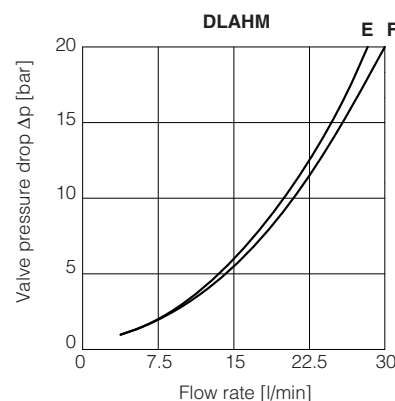
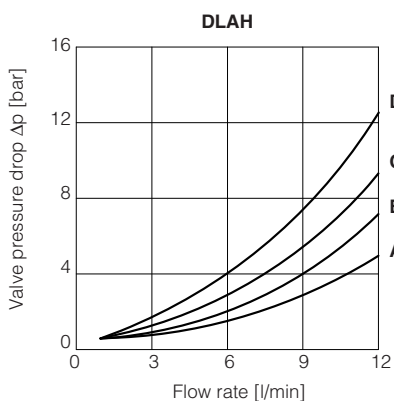

14 OPERATING LIMITS (based on mineral oil ISO VG 46 at 50°C)

DLAH, CART LAH

A = CART LAH-3A, DLAH-3A;

B = CART LAH-2A, DLAH-2A,
CART LAH-3C, DLAH-3C

DLAHM, CART LAHM

C = CART LAHM-3A, DLAHM-3A;

D = CART LAHM-3C, DLAHM-3C

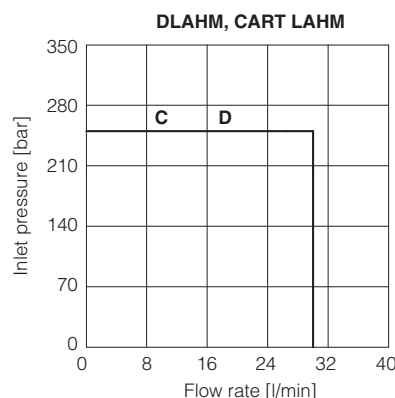
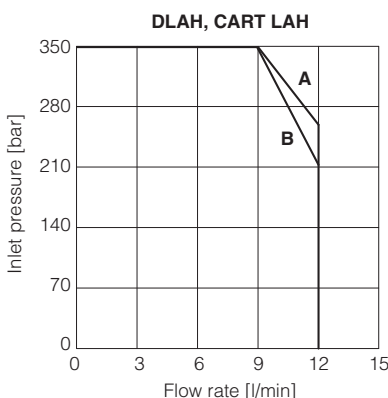

DLAH-2*

ISO 4401: 2005 (see table P005)

Mounting surface: 4401-03-02-0-05
without A and B ports

Fastening bolts:
4 socket head screws M5x50 class 12.9
Tightening torque = 8 Nm
Seals: 2 OR 108
Ports P, T: Ø = 7,5 mm (max)

P = PRESSURE PORT
T = USE PORT

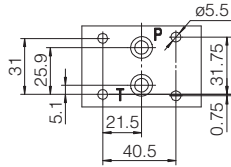

DLAH-3*

ISO 4401: 2005 (see table P005)

Mounting surface: 4401-03-02-0-05

Fastening bolts: 4 socket head screws:
M5X50 class 12.9
Tightening torque = 8 Nm
Seals: 4 OR 108
Ports P,A,B,T: Ø = 7.5 mm (max)

P = PRESSURE PORT
A = USE PORT (not used for DLAH-3C version)
B = USE PORT (not used for DLAH-3A version)
T = TANK PORT

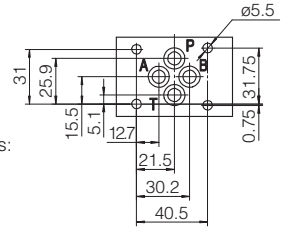

Mass [kg]	
DLAH-2*	2,65
DLAH-3*	2,65
Option /O	+0,35
Option /WP	+0,25

DLAH-2A, DLHA-2C

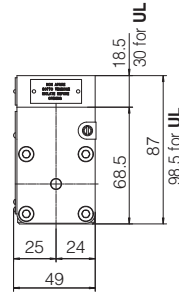
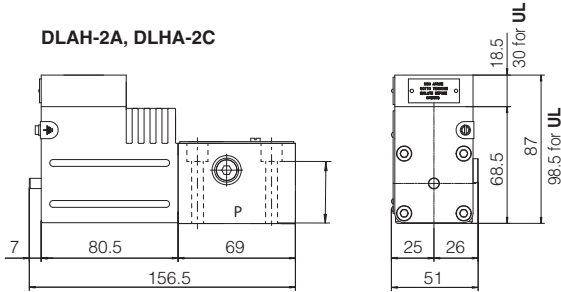

DLAH-3A, DLAH-3C

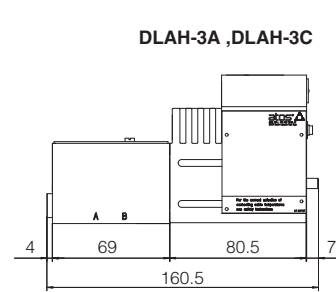

DLAH-2A /O, DLHA-2C /O

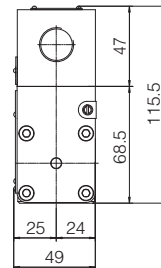
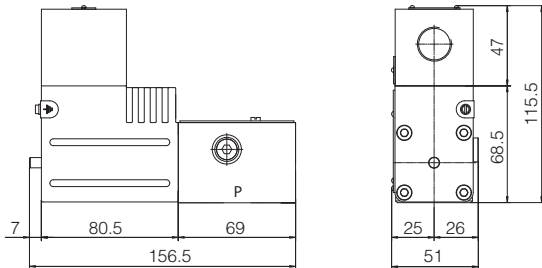

DLAH-3A /O, DLAH-3C /O

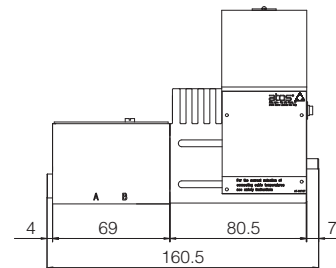

DLAH-2A /WP, DLHA-2C /WP

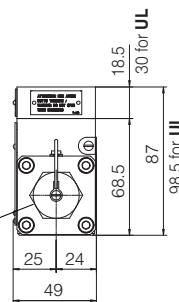
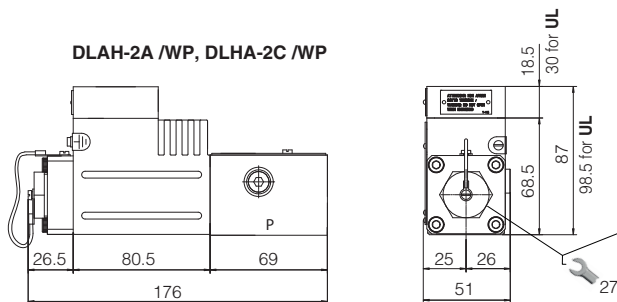

DLAH-3A /WP, DLAH-3C

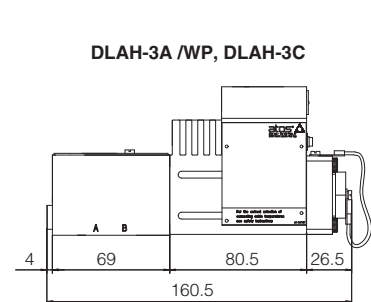

DLAHM-3*

ISO 4401: 2005 (see table P005)

Mounting surface: 4401-03-02-0-05

Fastening bolts: 4 socket head screws:

M5X50 class 12.9

Tightening torque = 8 Nm

Seals: 4 OR 108

Ports P,A,B,T: $\varnothing = 7.5$ mm (max)

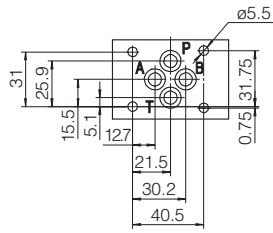

Mass [kg]	
DLAHM-3*	2,85
Option /O	+0,35
Option /WP	+0,25

P = PRESSURE PORT
A = USE PORT
B = not used
T = TANK PORT

DLAHM-3C

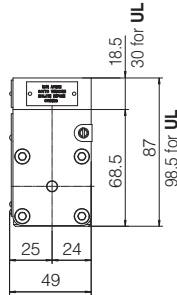
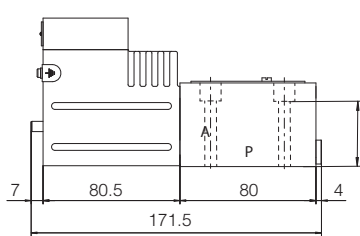

DLAHM-3A

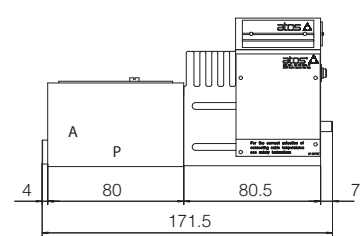

DLAHM-3C /O

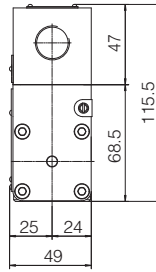
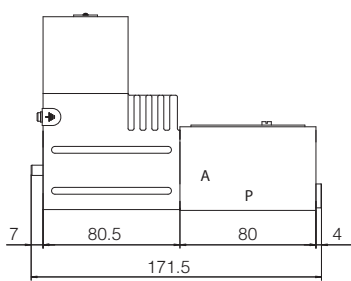

DLAHM-3A /O

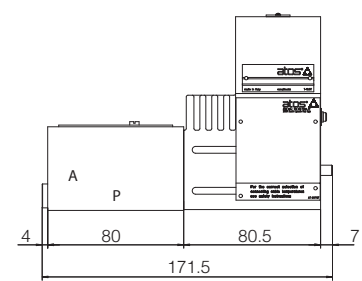

DLAHM-3C /WP

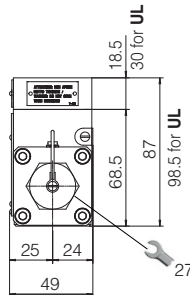
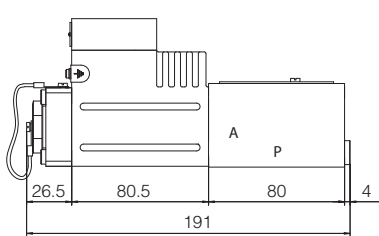

DLAHM-3A /WP

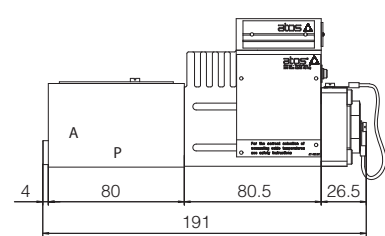

16 INSTALLATION DIMENSIONS FOR SCREW-IN VERSION [mm] - Multicertified and UL

CART LAH-2A
CART LAH-2C

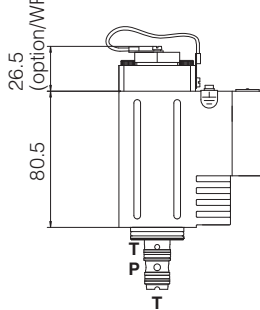

CART LAH-3A
CART LAH-3C

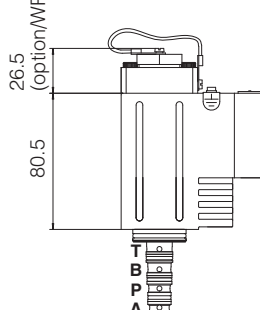

CART LAHM-3A
CART LAHM-3C

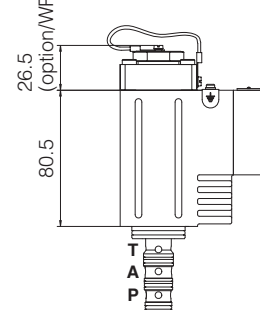

17 RELATED DOCUMENTATION

X010	Basics for electrohydraulics in hazardous environments
X020	Summary of Atos ex-proof components certified to ATEX, IECEx, EAC, PESO
X030	Summary of Atos ex-proof components certified to cULus
EX900	Operating and maintenance information for ex-proof on-off valves

KX800	Cable glands for ex-proof valves
P005	Mounting surfaces for electrohydraulic valves
P006	Mounting surfaces and cavities for cartridge valves