

Ex-proof solenoid directional valves

on-off, piloted - **ATEX, IECEX, EAC, PESO** or **cULus**

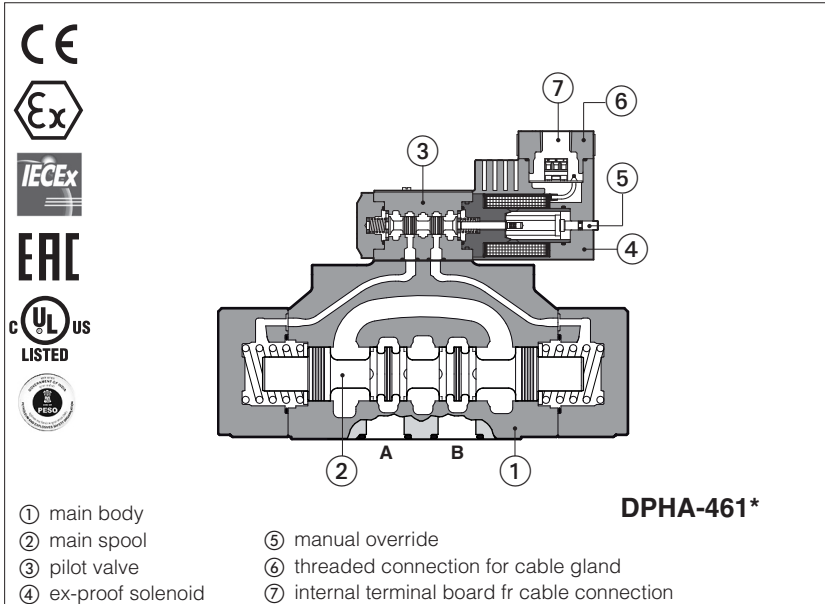

DPHA

On-off spool type, piloted directional valves equipped with ex-proof solenoids certified for safe operation in hazardous environments with potentially explosive atmosphere.

Certifications:

- Multicertification **ATEX, IECEX, EAC** and **PESO** for gas group **II 2G** and dust category **II 2D**
- Multicertification **ATEX** and **IECEX** for gas group **I M2** (mining)
- **cULus** North American certification for gas group **C&D**

The flameproof enclosure of solenoid prevents the propagation of accidental internal sparks or fire to the external environment.

The solenoid is also designed to limit the surface temperature within the classified limits.

Size: **10 ÷ 32** - ISO 4401

Max flow: **160 ÷ 1000 l/min**

Max pressure: **350 bar**

1 MODEL CODE

DPHA	/	*	-	2	63	1/2	/	M	/	*	24DC	**	/	*
Ex-proof directional valve, piloted														
Certification type: Multicertification ATEX, IECEX, EAC, PESO: - = omit for Group II 2G / II 2D (1) M = Group I M2 (mining) North American certification UL = cULus														Seals material, see section [8] : - = NBR PE = FKM BT = HNBR (3)
Valve size (ISO 4401) 1 = 10 2 = 16 4 = 25 6 = 32														Series number
Configuration , see section [2]														Voltage code , see section [7]
Spool type , see section [2]														
Solenoid threaded connection for cable gland fitting: GK = GK-1/2" - not for cULus (3) M = M20x1,5 - not for cULus NPT = 1/2" NPT														
														Options (4): A = solenoid at side of port B (for single solenoid valves) O = horizontal cable entrance (3) /D = Internal drain /E = external pilot pressure /H = adjustable chokes (meter-out to the pilot chambers of the main valve) /H9 = adjustable chokes (meter-in to the pilot chambers of the main valve) L1, L2, L3 = calibrated restrictors in A and B ports of pilot valve /L9 = (only for DPHA-2 and DPHA-4) plug with calibrated restrictor on port P of pilot valve /R = pilot pressure generator (not for DPHA-1) /S = main spool stroke adjustment (not for DPHA-1) WP = manual override protected by metallic cap

- (1)** The valves with Multicertification for Group II are also certified for Indian market according to **PESO** (Petroleum and Explosives Safety Organization). The PESO certificate can be downloaded from www.atos.com **(2)** Approved only for the Italian market
(3) Not for multicertification **M** group I (mining) **(4)** For possible combined options, see **[10]**

For valves with external drain (option /D), the pressure at T port makes difficult the manual override operation that can be possible only if its value is lower than 50 bar.

2 CONFIGURATIONS AND SPOOLS

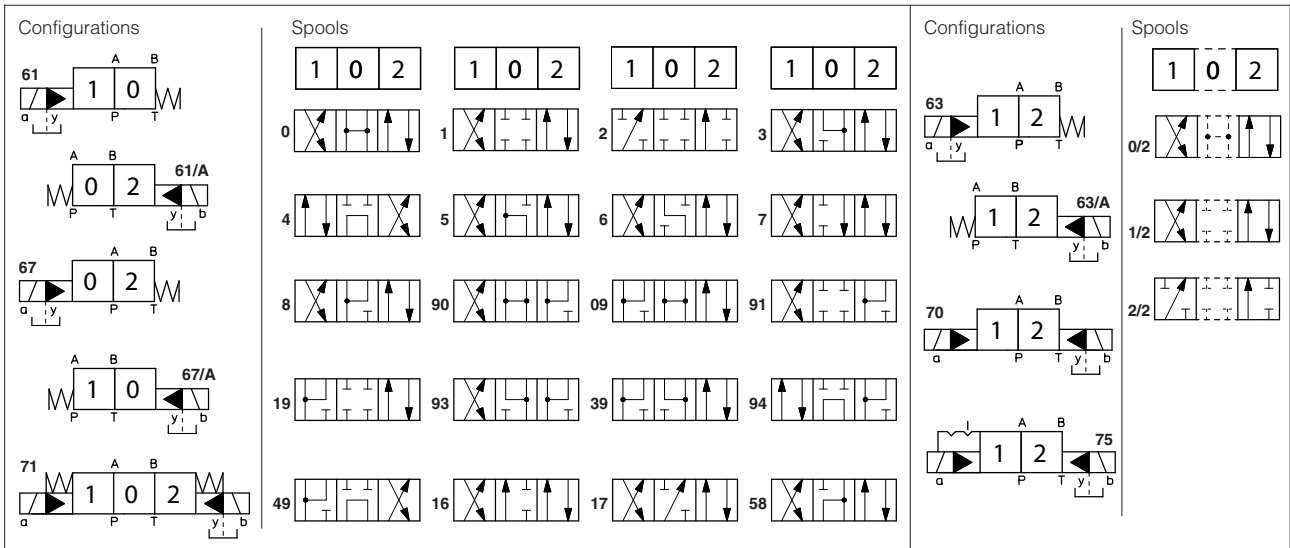

2.1 Standard spools availability

- DPHA-1 are available only with spools **0, 0/2, 1, 1/2, 3, 4, 5, 58, 6, 7**
- DPHA-2 and DPHA-4 are available with all spools shown in the above table
- DPHA-6 are available only with spools **0, 1, 1/2, 2, 3, 4, 5, 58, 6, 7, 8, 19, 91**

2.2 Special shaped spools

- spools type **0** and **3** are also available as **0/1** and **3/1** with restricted oil passages in central position, from user ports to tank.
- spools type **1, 4, 5, 58, 6** and **7** are also available as **1/1, 4/8, 5/1, 58/1, 6/1** and **7/1** that are properly shaped to reduce water-hammer shocks during the switching (to use with option /L*).

2.3 Special spool availability

Valve size	standard spools							
	0/1	3/1	1/1	4/8	5/1	58/1	6/1	7/1
DPHA-1	•	•		•				
DPHA-2, DPHA-4	•	•	•	•	•	•	•	•
DPHA-6		•	•	•				

3 DEVICES FOR MAIN SPOOL SWITCHING CONTROL

Folowing options are suggested to reduce the hydraulic shocks at the valve operation

/H = Adjustable chokes (meter-out to the pilot chambers of the main valve).

/H9 = Adjustable chokes (meter-in to the pilot chambers of the main valve).

/L1, /L2, /L3 = calibrated restrictors on A and B ports of the pilot valve:

L1 = 0,8 mm, **L2** = 1 mm, **L3** = 1,25 mm

/L9 (only for DPHA-2 and DPHA-4) plug with calibrated restrictor in P port of pilot valve see section **16**

Suggested for pilot pressure higher than 210 bar or to limit the hydraulics shocks caused by the fast main spool switching

FUNCTIONAL SCHEME (config. 71)
example of switching control options

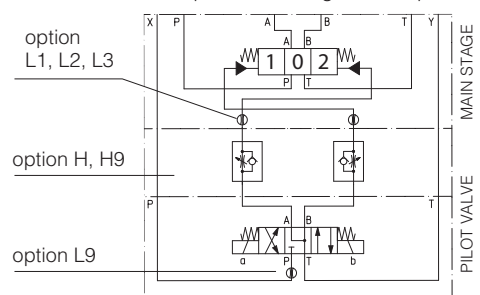

4 PILOT PRESSURE GENERATOR (OPTION /R)

The device **/R** generates an additional pressure drop, in order to ensure the minimum pilot pressure, for correct operation of the valves with internal pilot and fitted with spools type **0, 0/1, 4, 4/8, 5, 58, 09, 90, 94, 49**. The device **/R** has to be fitted when the pressure drop in the valve, verified on flow versus pressure diagrams, is lower than the minimum pilot pressure value.

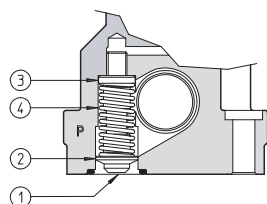

- ① Flapper-guide
- ② Flapper
- ③ Spring stop-washer
- ④ Spring

Ordering code of spare pilot pressure generator

R/DP	-	*
Pilot pressure generator		Size: 2 for DPHA-2 4 for DPHA-4 6 for DPHA-6 Not available for DPHA-1

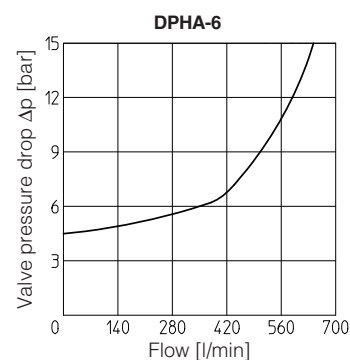
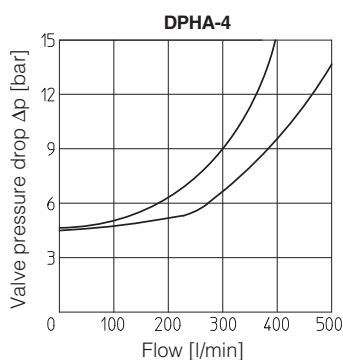
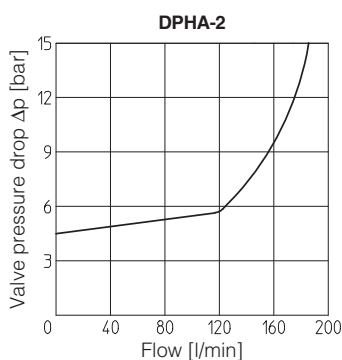

5 GENERAL CHARACTERISTICS

Assembly position / location	Any position
Subplate surface finishing to ISO 4401	Acceptable roughness index, Ra ≤0,8 recommended Ra 0,4 - flatness ratio 0,01/100
MTTFd values according to EN ISO 13849	75 years, for further details see technical table P007
Ambient temperature	Standard = -20°C ÷ +70°C /PE option = -20°C ÷ +70°C /BT option = -40°C ÷ +70°C
Storage temperature range	Standard = -20°C ÷ +80°C /PE option = -20°C ÷ +80°C /BT option = -40°C ÷ +70°C
Surface protection	Zinc coating with black passivation - salt spray test (EN ISO 9227) > 200 h
Compliance	Explosion proof protection, see section 9 -Flame proof enclosure "Ex d" -Dust ignition protection by enclosure "Ex t" RoHs Directive 2011/65/EU as last update by 2015/65/EU REACH Regulation (EC) n°1907/2006

6 HYDRAULIC CHARACTERISTICS

Operating pressure	P, A, B, X = 350 bar T = 250 bar with external drain (standard) T and Y = 210 bar with internal drain (option /D) Minimum pilot pressure for correct operation is = 8 bar
Rated flow	See diagrams Q/Δp at section 14
Maximum flow	DPHA-1: 160 l/min ; DPHA-2: 300 l/min ; DPHA-4: 700 l/min ; DPHA-6: 1000 l/min see Q/Δp diagrams at section 14 and operating limits at section 15

7 ELECTRICAL CHARACTERISTICS

Valve type	DPHA	DPHA/M	DPHA/UL
Voltage code (1) $V_{DC} \pm 10\%$	12DC, 24DC, 28DC, 48DC, 110DC, 125DC, 220DC		12DC, 24DC, 110DC, 125DC, 220DC
$V_{AC} 50/60 \text{ Hz} \pm 10\%$	12AC, 24AC, 110AC, 230AC		12AC, 24AC, 110AC, 230AC
Power consumption at 20°C	8W		12W
Coil insulation	class H		
Protection degree with relevant cable gland	IP66/67 to DIN EN60529		raintight enclosure, UL approved
Duty factor	100%		

(1) For alternating current supply a rectifier bridge is provided built-in the solenoid
For power supply frequency 60 Hz, the nominal supply voltage of solenoids 110AC and 230AC must be 115/60 and 240/60 respectively

8 SEALS AND HYDRAULIC FLUIDS - for other fluids not included in below table, consult our technical office

Seals, recommended fluid temperature	NBR seals (standard) = -20°C ÷ +60°C, with HFC hydraulic fluids = -20°C ÷ +50°C FKM seals (/PE option) = -20°C ÷ +80°C HNBR seals (/BT option) = -40°C ÷ +60°C, with HFC hydraulic fluids = -40°C ÷ +50°C		
Recommended viscosity	15 ÷ 100 mm ² /s - max allowed range 2.8 ÷ 500 mm ² /s		
Max fluid contamination level	ISO4406 class 20/18/15 NAS1638 class 9, see also filter section at www.atos.com or KTF catalog		
Hydraulic fluid	Suitable seals type	Classification	Ref. Standard
Mineral oils	NBR, FKM, HNBR	HL, HLP, HLPD, HVLP, HVLPD	DIN 51524
Flame resistant without water	FKM	HFDU, HFDR	ISO 12922
Flame resistant with water	NBR, HNBR	HFC	

 The ignition temperature of the hydraulic fluid must be 50°C higher than the max solenoid surface temperature

(1) Performance limitations in case of flame resistant fluids with water:

- max operating pressure = 210 bar
- max fluid temperature = 50°C

9 CERTIFICATION DATA

Valve type	DPHA		DPHA/M	DPHA/UL	
Certifications	Multicertification Group II ATEX IECEx EAC PESO		Multicertification Group I ATEX IECEx	North American cULus cULus	
Solenoid certified code	OA		OA/M	OA/EC	
Type examination certificate (1)	ATEX: CESI 02 ATEX 014 IECEX: IECEx CES 10.0010x EAC: TC RU C-IT. 08.B.01784 PESO: P338131		ATEX: CESI 03 ATEX 057x IECEX: IECEx CES 12.0007x	20170324 - E366100	
Method of protection	<ul style="list-style-type: none"> • ATEX, EAC Ex II 2G Ex d IIC T6/T4/T3 Gb Ex II 2D Ex tb IIIC T85°C/T200°C Db • IECEx Ex d IIC T6/T4/T3 Gb Ex tb IIIC T85°C/T200°C Db • PESO Ex II 2G Ex d IIC T6/T4 Gb 		<ul style="list-style-type: none"> • ATEX Ex I M2 Ex db I Mb • IECEx Ex db I Mb 	<ul style="list-style-type: none"> • UL 1203 Class I, Div.I, Groups C & D Class I, Zone I, Groups IIA & IIB 	
Temperature class	T6	T4	-	T6	T5
Surface temperature	≤ 85 °C	≤ 135 °C	≤ 150 °C	≤ 85 °C	≤ 100 °C
Ambient temperature (2)	-40 ÷ +45 °C	-40 ÷ +70 °C	-20 ÷ +70 °C	-40 ÷ +55 °C	-40 ÷ +70 °C
Applicable standards	EN 60079-0: 2012+A11:2013 EN 60079-1:2014 EN 60079-31:2014		IEC 60079-0:2017 IEC 60079-1:2017-04 IEC 60079-31:2013	UL 1203 and UL429, CSA 22.2 n°30-1986 CSA 22.2 n°139-13	
Cable entrance: threaded connection vertical (standard) or horizontal (option /O)	GK = GK-1/2" M = M20x1,5 NPT = 1/2" NPT			1/2" NPT ANSI/ASME B46.1	

(1) The type examiner certificates can be downloaded from www.atos.com

(2) The solenoids **Group II** and **cULus** are certified for minimum ambient temperature -40°C

In case the complete valve must withstand with minimum ambient temperature of -40°C, select **/BT** in the model code

 **WARNING: service work performed on the valve by the end users or not qualified personnel invalidates the certification**

10 OPTIONS

A = Solenoid at side of port B of the main stage (for single solenoid valves)

O = Horizontal cable entrance, to be selected in case of limited vertical space

/D = Internal drain

/E = External pilot pressure

/H = Adjustable chokes (meter-out to the pilot chambers of the main valve)

/H9 = Adjustable chokes (meter-in to the pilot chambers of the main valve)

L1, L2, L3 = Calibrated restrictors in A and B ports of pilot valve

/L9 = (only for DPHA-2 and DPHA-4) plug with calibrated restrictor on port P of pilot valve

/R = Pilot pressure generator (not for DPHA-1)

/S = Main spool stroke adjustment (not for DPHA-1)

WP = Manual override protected by metallic cap

11 EX PROOF SOLENOIDS WIRING

Multicertification

Standard version **Option /O**

① cover with threaded connection for vertical cable gland fitting
 ② cover with threaded connection for horizontal cable gland fitting
 ③ terminal board for cables wiring
 ④ standard manual override
 ⑤ screw terminal for additional equipotential grounding

① = Coil PCB 3 poles terminal board
 ② = GND suitable for wires cross sections
 ③ = Coil up to 2,5 mm² (max AWG14)

cULus certification

Standard version **Option /O**

① cover with threaded connection for vertical cable gland fitting
 ② cover with threaded connection for horizontal cable gland fitting
 ③ terminal board for cables wiring
 ④ standard manual override

Pay attention to coil polarity

① = Coil + PCB 3 poles terminal board suggested cable section up to 1,5 mm²
 ② = GND
 ③ = Coil - (max AWG16), see section [12] note 1

alternative GND screw terminal connected to solenoid housing

12 CABLE SPECIFICATION AND TEMPERATURE - Power supply and grounding cables have to comply with following characteristics:

Multicertification Group I and Group II
Power supply: section of coil connection wires = 2,5 mm² **Grounding:** section of internal ground wire = 2,5 mm²
 section of external ground wire = 4 mm²

cULus certification:

- Suitable for use in Class I Division 1, Gas Groups C
- Armored Marine Shipboard Cable which meets UL 1309
- Tinned Stranded Copper Conductors
- Bronze braided armor
- Overall impervious sheath over the armor

Any Listed (UBVZ/UBVZ7) Marine Shipboard Cable rated 300 V min, 15A min. 3C 2,5 mm² (14 AWG) having a suitable service temperature range of at least -25°C to +110°C ("BT" Models require a temperature range from -40°C to +110°C)

Note 1: For Class I wiring the 3C 1,5 mm² AWG 16 cable size is admitted only if a fuse lower than 10 A is connected to the load side of the solenoid wiring.

12.1 Cable temperature

The cable must be suitable for the working temperature as specified in the "safety instructions" delivered with the first supply of the products.

Multicertification

Max ambient temperature [°C]	Temperature class		Max surface temperature [°C]		Min cable temperature
	Group I	Group II	Group I	Group II	
45 °C	-	T6	150 °C	85 °C	not prescribed
70 °C	-	T4	150 °C	135 °C	90 °C

cULus certification

Max ambient temperature [°C]	Temperature class	Max surface temperature [°C]	Min cable temperature
55 °C	T6	85 °C	100 °C
70 °C	T5	100 °C	100 °C

13 CABLE GLANDS only for Multicertification

Cable glands with threaded connections GK-1/2", 1/2"NPT or M20x1,5 for standard or armoured cables have to be ordered separately, see tech. table **KX800**

Note: a Loctite sealant type 545, should be used on the cable gland entry threads

14 FLOW VERSUS PRESSURE DIAGRAMS Based on mineral oil ISO VG 46 at 50°C

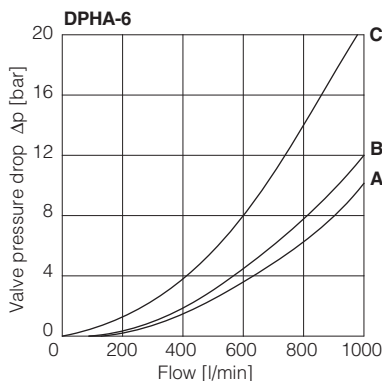
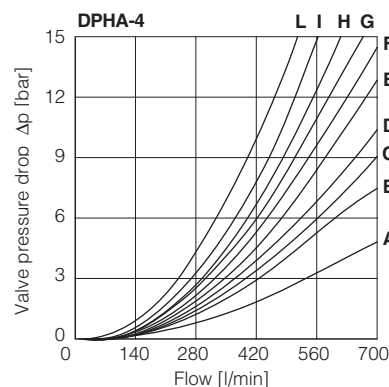
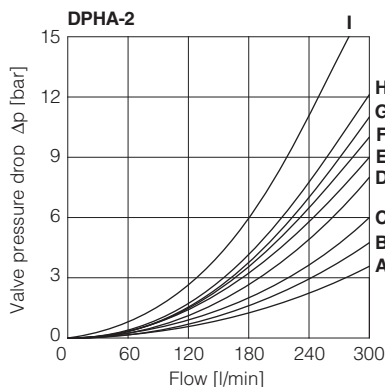
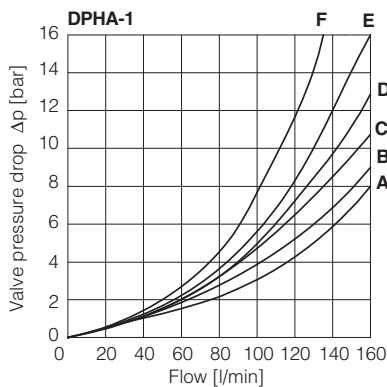

DPHA-2

Spool type	Flow direction				
	P→A	P→B	A→T	B→T	P→T
0/2, 1, 3, 6, 7, 8	A	A	D	A	-
1/1, 1/2, 7/1	B	B	D	E	-
0	A	A	D	E	C
0/1	A	A	D	-	-
2	A	A	-	-	-
2/2	B	B	-	-	-
3/1	A	A	D	D	-
4	C	C	H	I	F
4/8	C	C	G	I	F
5	A	B	F	H	G
5/1	A	B	D	F	-
6/1	B	B	C	E	-
09	A	-	-	G	-
16	A	C	D	F	-
17	C	A	E	F	-
19	C	-	-	G	-
39	C	-	-	H	-
49	-	D	-	-	-
58	B	A	F	H	H
58/1	B	A	D	F	-
90	A	A	E	-	D
91	C	C	E	-	-
93	-	C	D	-	-
94	D	-	-	-	-

DPHA-4

Spool type	Flow direction				
	P→A	P→B	A→T	B→T	P→T
1	B	B	B	D	-
1/1	D	E	E	F	-
1/2	E	D	B	C	-
0	D	C	D	E	F
0/1, 3/1, 5/1, 6, 7	D	D	D	F	-
0/2	D	D	D	E	-
2	B	B	-	-	-
2/2	E	D	-	-	-
3	B	B	D	F	-
4	C	C	H	L	L
5	A	D	D	D	H
6/1	D	E	D	F	-
7/1	D	E	F	F	-
8	D	D	E	F	-
09	D	-	-	F	F
16	C	D	E	F	-
17	E	D	E	F	-
19	F	-	-	E	-
39	G	F	-	F	-
58	E	A	B	F	H
58/1	E	D	D	F	-
90	D	D	D	-	F
91	F	F	D	-	-
93	-	G	D	-	-

DPHA-1

Spool type	Flow direction				
	P→A	P→B	A→T	B→T	P→T
0/2, 1/2	D	E	D	C	-
0	D	E	C	C	E
1	A	B	D	C	-
3, 6, 7	A	B	C	C	-
4, 4/8	B	C	D	D	-
5, 58	A	E	C	C	F

DPHA-6

Spool type	Flow direction				
	P→A	P→B	A→T	B→T	P→T
0	A	A	B	B	B
1	A	A	A	B	-
3	A	-	A	B	-
4	A	A	C	C	C

15 OPERATING LIMITS For a correct valve operation do not exceed the max recommended flow rates (l/min) shown in the below tables

DPHA-1

Spool type	Inlet pressure [bar]			
	70	160	210	350
	Flow rate [l/min]			
0, 1, 3, 6, 7	160	160	160	145
4, 4/8	160	160	135	100
5, 58	160	160	145	110
0/1, 0/2, 1/2	160	160	145	135

DPHA-2

Spool type	Inlet pressure [bar]			
	70	140	210	350
	Flow rate [l/min]			
0, 1, 3, 6, 7, 8	300	300	300	300
2, 4, 4/8	300	300	240	140
5	260	220	180	100
0/1, 0/2, 1/2	300	250	210	180
16, 17, 56, *9, 9*	300	300	270	200

DPHA-4

Spool type	Inlet pressure [bar]			
	70	140	210	350
	Flow rate [l/min]			
1, 6, 7, 8	700	700	700	600
2, 4, 4/8	500	500	450	400
5, 0/1, 0/2, 1/2	600	520	400	300
0, 3	700	700	600	540
16, 17, 58, *9, 9*	500	500	500	450

DPHA-6

Spool type	Inlet pressure [bar]			
	70	140	210	350
	Flow rate [l/min]			
1, 3, 6, 7, 8	1000	950	850	700
0	950	900	800	650
2, 4, 4/8, 5	850	800	700	450
0/1, 58, 19, 91	950	850	650	450

16 PLUGS LOCATION FOR PILOT/DRAIN CHANNELS

Depending on the position of internal plugs, different pilot/drain configurations can be obtained as shown below. To modify the pilot/drain configuration, proper plugs must only be interchanged. The plugs have to be sealed using loctite 270. Standard valves configuration provides internal pilot and external drain

DPHA-1

Pilot channels

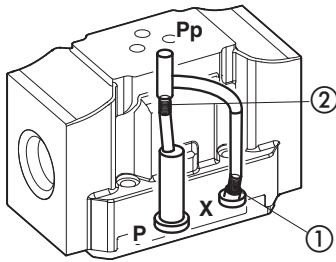

Drain channels

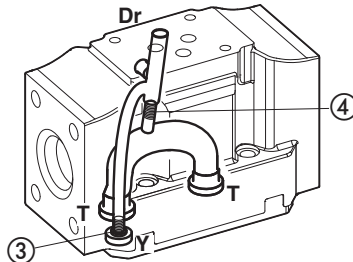

Internal piloting: blinded plug SP-X300F ① in X; plug SP-X310F ② in Pp;
External piloting: blinded plug SP-X300F ② in Pp; plug SP-X310F ① in X;
Internal drain: blinded plug SP-X300F ③ in Y;
External drain: blinded plug SP-X300F ④ in Dr.

DPHA-2

Pilot channels

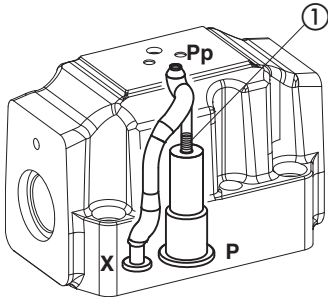

Drain channels

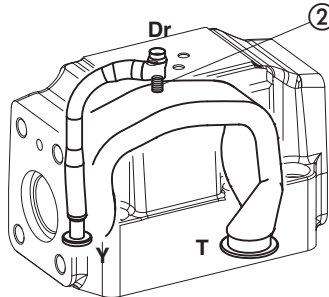

Internal piloting: Without blinded plug SP-X300F ①;
External piloting: Add blinded plug SP-X300F ①;
Internal drain: Without blinded plug SP-X300F ②;
External drain: Add blinded plug SP-X300F ②.

Option L9

This option provides a calibrated restrictor PLUG-H-12A (Ø 1,2 mm) in the P port of the pilot valve

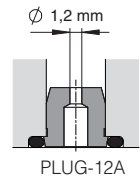

DPHA-4

Pilot channels

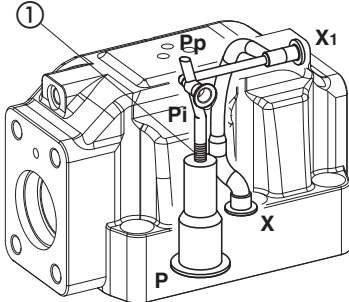

Drain channels

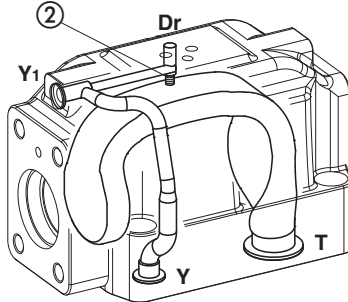

Internal piloting: Without blinded plug SP-X500F ①;
External piloting: Add blinded plug SP-X500F ①;
Internal drain: Without blinded plug SP-X300F ②;
External drain: Add blinded plug SP-X300F ②.

Option L9

This option provides a a calibrated restrictor PLUG-H-15A (Ø 1,5 mm) in the P port of the pilot valve

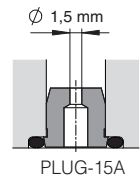

DPHA-6

Pilot channels

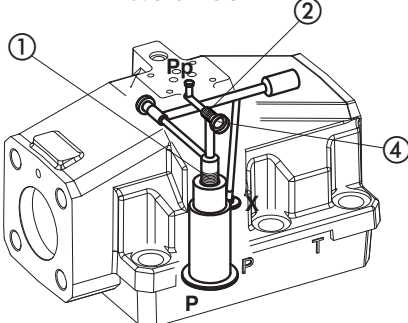

Drain channels

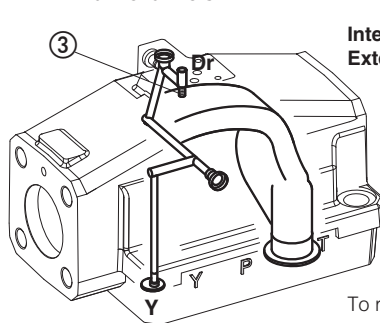

Internal piloting: Without plug ①;
External piloting: Add DIN-908 M16x1,5 in pos ①; plug SP-X325A in pos ②;
Internal drain: Without blinded plug SP-X300F ③;
External drain: Add blinded plug SP-X300F ③.

To reach the orifice ②, remove plug ④ = G 1/8"

DPHA-1*

ISO 4401: 2005

Mounting surface: 4401-05-05-0-05

Fastening bolts:

4 socket head screws M6x40 class 12.9

Tightening torque = 15 Nm

Diameter of ports A, B, P, T: $\varnothing = 11$ mm;

Diameter of ports X, Y: $\varnothing = 5$ mm;

Seals: 5 OR 2050, 2 OR 108

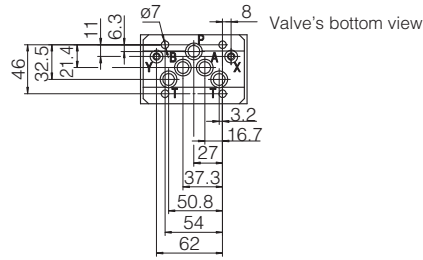

- P** = PRESSURE PORT
- A, B** = USE PORT
- T** = TANK PORT
- X** = EXTERNAL PILOT PORT
- Y** = DRAIN PORT

Mass [kg]	
DPHA-16	8,0
DPHA-17	9,5
Option /WP	+0,25
Option /O	+0,35
Option /H, /H9	+1,0

DPHA-16
DPHA-17 (dotted line)

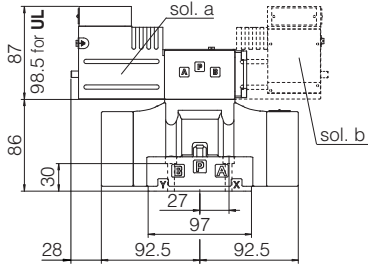

Option /WP

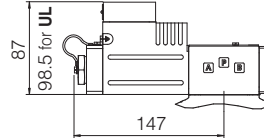

Option /O

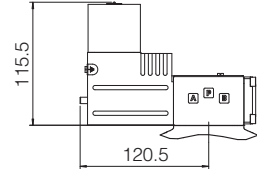

Option /H; /H9

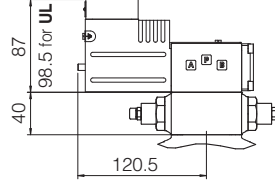

DPHA-2*

ISO 4401: 2005

Mounting surface: 4401-07-07-0-05

Fastening bolts:

4 socket head screws M10x50 class 12.9

Tightening torque = 70 Nm

2 socket head screws M6x45 class 12.9

Tightening torque = 15 Nm

Diameter of ports A, B, P, T: $\varnothing = 20$ mm;

Diameter of ports X, Y: $\varnothing = 7$ mm;

Seals: 4 OR 130, 2 OR 2043

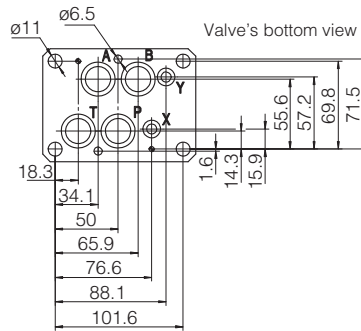

- P** = PRESSURE PORT
- A, B** = USE PORT
- T** = TANK PORT
- X** = EXTERNAL PILOT PORT
- Y** = DRAIN PORT

Mass [kg]	
DPHA-26	11
DPHA-27	12,5
Option /WP	+0,25
Option /O	+0,35
Option /S	+1,0
Option /H, /H9	+1,0

DPHA-26
DPHA-27 (dotted line)

Option /S

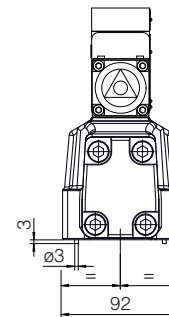
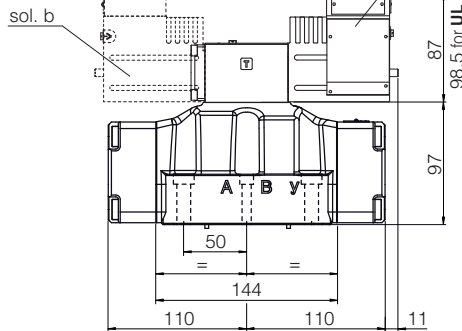
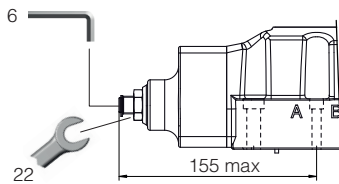

Option /WP

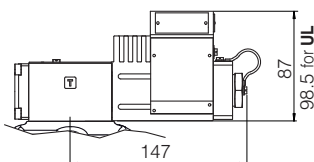

Option /O

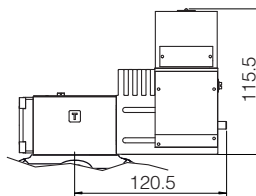

Option /H; /H9

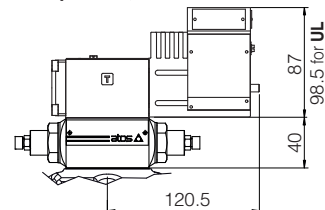

DPHA-4*

ISO 4401: 2005 (see table P005)

Mounting surface: 4401-08-08-0-05

Fastening bolts:

6 socket head screws M12x60 class 12.9

Tightening torque = 125 Nm

Seals: 4 OR 4112; 2 OR 3056

Diameter of ports A, B, P, T: $\varnothing = 24$ mm;

Diameter of ports X, Y: $\varnothing = 7$ mm;

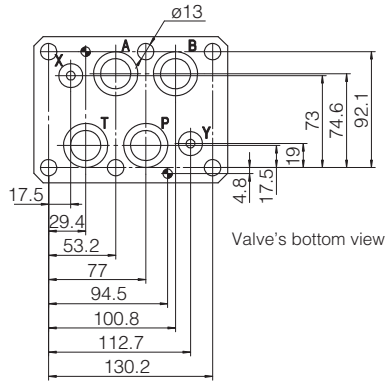

Valve's bottom view

P = PRESSURE PORT
A, B = USE PORT
T = TANK PORT
X = EXTERNAL PILOT PORT
Y = DRAIN PORT

Mass [kg]	
DPHA-46	18,5
DPHA-47	20,0
Option /WP	+0,25
Option /O	+0,35
Option /S	+1,5
Option /H, /H9	+1,0

DPHA-46
 DPHA-47 (dotted line)

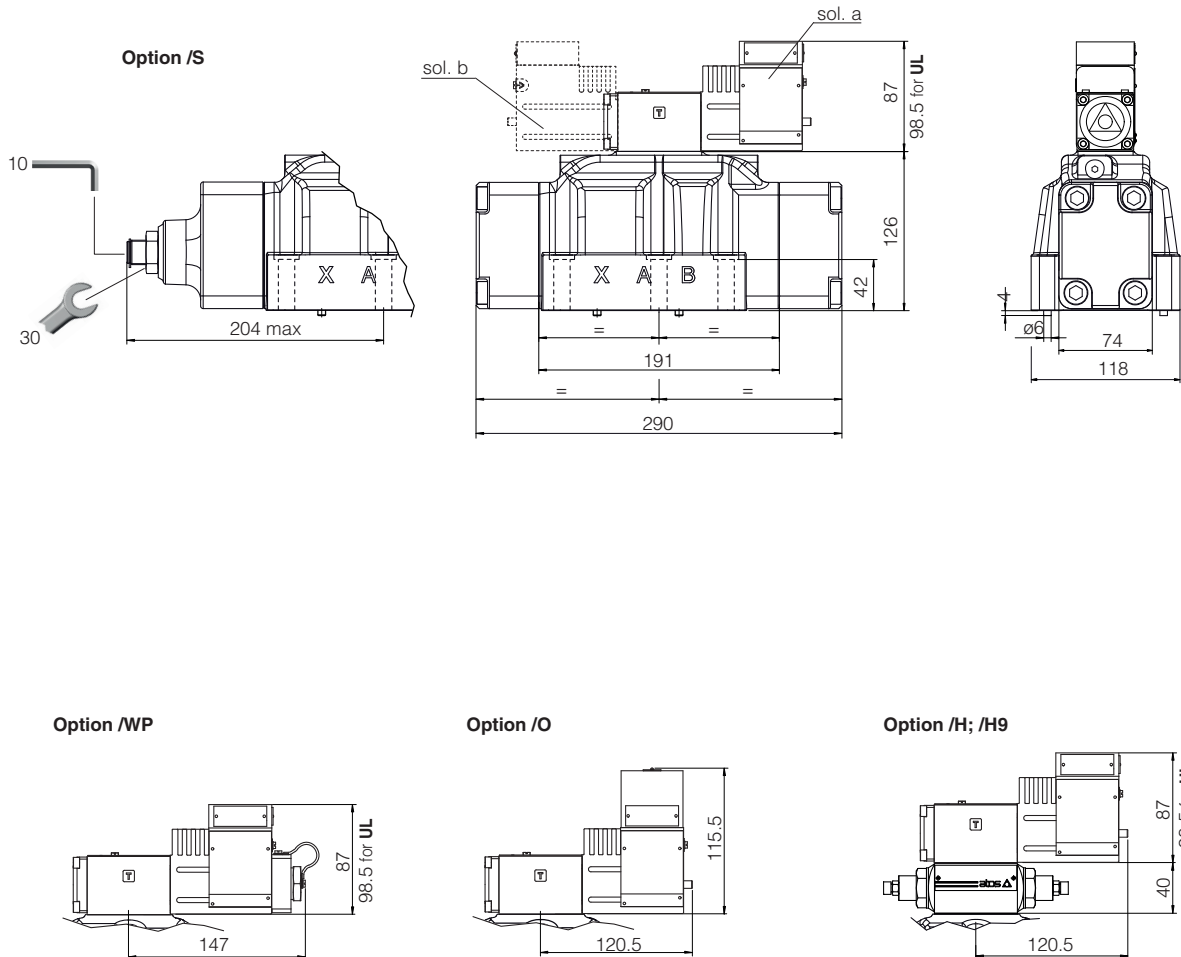

DPHA-6*

ISO 4401: 2005

Mounting surface: 4401-10-09-0-05

Fastening bolts:
6 socket head screws M20x80 class 12.9
Tightening torque = 600 Nm
Diameter of ports A, B, P, T: $\varnothing = 34$ mm;
Diameter of ports X, Y: $\varnothing = 7$ mm;
Seals: 4 OR 144, 2 OR 3056

Mass [kg]	
DPHA-66	45,0
DPHA-67	46,5
Option /WP	+0,25
Option /O	+0,35
Option /S	+3,5
Option /H, /H9	+1,0

Valve's bottom view

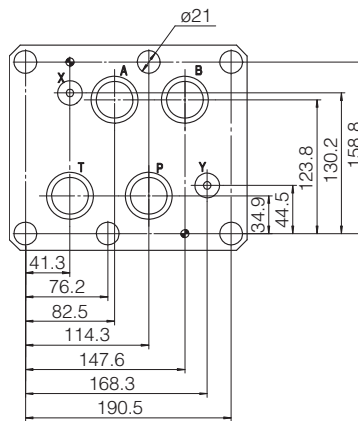

P = PRESSURE PORT
A, B = USE PORT
T = TANK PORT
X = EXTERNAL OIL PILOT PORT
Y = DRAIN PORT

DPHA-66
DPHA-67 (dotted line)

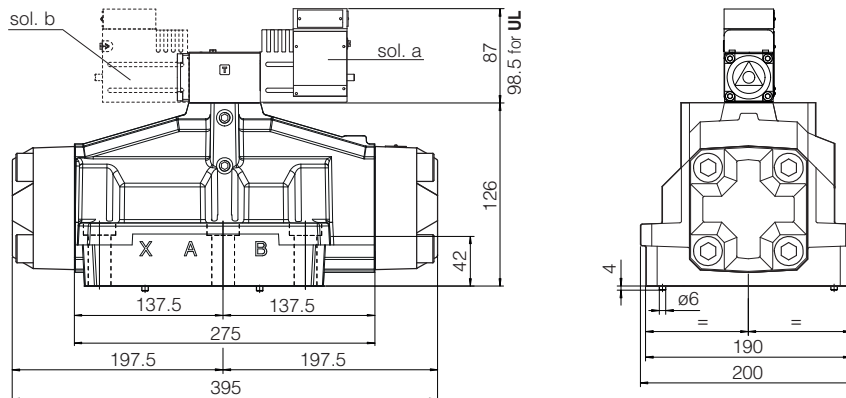

Option /S

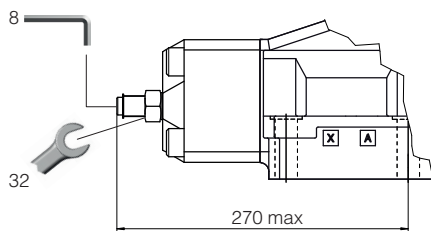

Option /WP

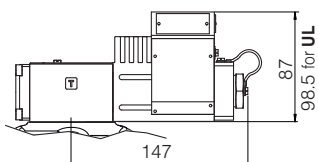

Option /O

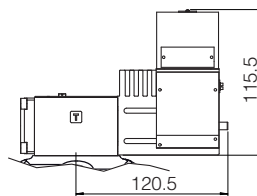

Option /H; /H9

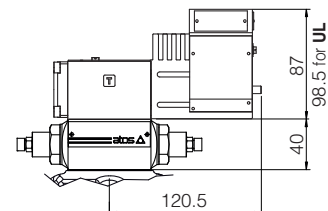

18 RELATED DOCUMENTATION

X010 Basics for electrohydraulics in hazardous environments
X020 Summary of Atos ex-proof components certified to ATEX, IECEx, EAC, PESO
X030 Summary of Atos ex-proof components certified to cULus

EX900 Operating and maintenance information for ex-proof on-off valves
KX800 Cable glands for ex-proof valves
P005 Mounting surfaces for electrohydraulic valves