

Ex-proof digital proportional flow valves high performance

pressure compensated, with LVDT transducer and on-board driver - **ATEX and IECEx**

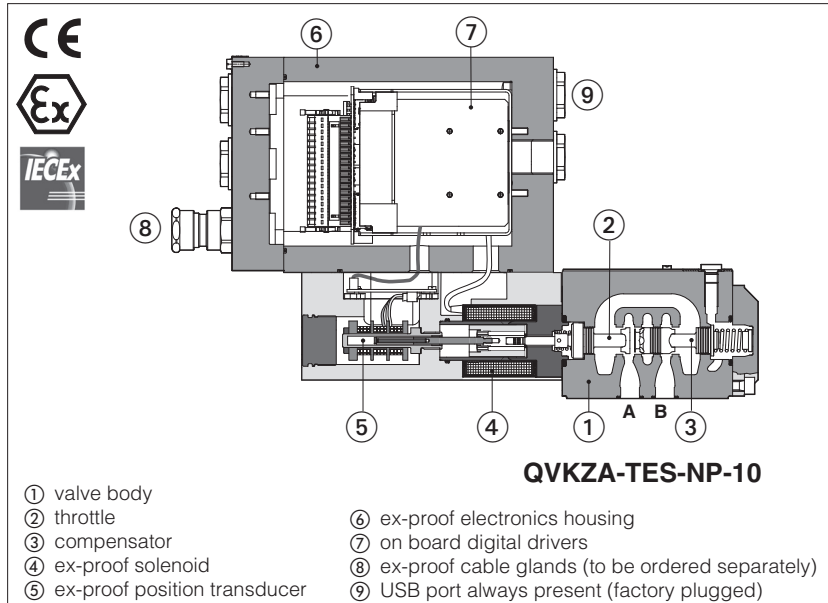

QVHZA-TES, QVKZA-TES

Pressure compensated, ex-proof digital high performance proportional flow valves, with LVDT position transducer for closed loop flow regulation.

They are equipped with ex-proof on-board digital driver, LVDT transducer and solenoid certified for safe operations in hazardous environments with potentially explosive atmosphere.

● Multicertification **ATEX** and **IECEx**
for gas group **II 2G** and dust category **II 2D**

The flameproof enclosure of integral digital driver and solenoid prevents the propagation of accidental internal sparks or fire to the external environment.

The driver and solenoid are also designed to limit the surface temperature within the classified limits.

QVHZA:	QVKZA:
Size: 06 - ISO4401	Size: 10 - ISO4401
Max flow: 45 l/min	Max flow: 90 l/min
Max pressure: 210 bar	Max pressure: 210 bar

1 MODEL CODE

QVKZA	-	T	-	ES	-	NP	-	10	/	65	/	M	*	/	**	/	*										
<p>Ex-proof pressure compensated proportional flow valves, direct</p> <p>QVHZA = size 06 QVKZA = size 10</p> <p>T = with LVDT transducer</p> <p>ES = full integral driver</p> <p>Fieldbus interfaces, USB port always present: NP = Not Present BC = CANopen BP = PROFIBUS DP EH = EtherCAT</p> <p>Valve size ISO 4401: 06 = size 06 (QVHZA) 10 = size 10 (QVKZA)</p> <p>Seals material, see section 9: - = NBR PE = FKM BT = HNBR</p> <p>Electronic options: I = current reference input and monitor 4 ÷ 20 mA (omit for std voltage ±10 Vdc)</p> <p>Cable entrance threaded connection: M = M20x1,5</p> <p>Max regulated flow:</p> <table border="0" style="width: 100%;"> <tr> <td>QVHZA:</td> <td>QVKZA:</td> </tr> <tr> <td>3 = 3,5 l/min</td> <td>36 = 35 l/min</td> </tr> <tr> <td>12 = 12 l/min</td> <td>45 = 45 l/min</td> </tr> <tr> <td>18 = 18 l/min</td> <td>90 = 90 l/min</td> </tr> <tr> <td></td> <td>65 = 65 l/min</td> </tr> </table>																		QVHZA:	QVKZA:	3 = 3,5 l/min	36 = 35 l/min	12 = 12 l/min	45 = 45 l/min	18 = 18 l/min	90 = 90 l/min		65 = 65 l/min
QVHZA:	QVKZA:																										
3 = 3,5 l/min	36 = 35 l/min																										
12 = 12 l/min	45 = 45 l/min																										
18 = 18 l/min	90 = 90 l/min																										
	65 = 65 l/min																										

2 HYDRAULIC SYMBOLS

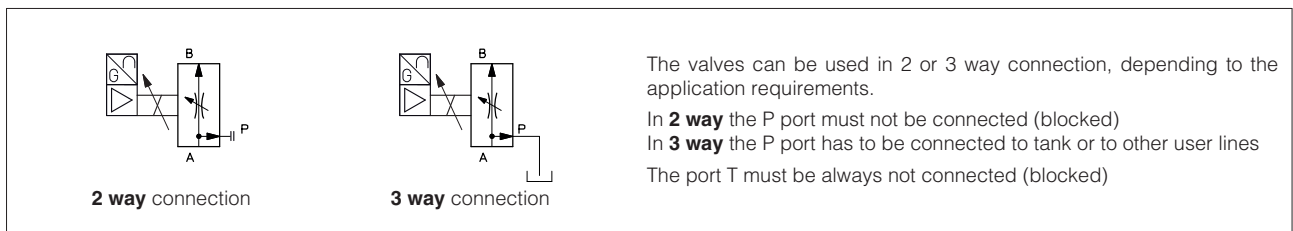

3 GENERAL NOTES

Atos digital proportionals valves are CE marked according to the applicable directives (e.g. Immunity and Emission EMC Directive). Installation, wirings and start-up procedures must be performed according to the general prescriptions shown in tech table **F003** and in the user manuals included in the E-SW-* programming software.

4 VALVE SETTINGS AND PROGRAMMING TOOLS

WARNING: the below operation must be performed in a safety area

Valve's functional parameters and configurations, can be easily set and optimized using Atos E-SW programming software connected via USB port to the digital driver (see table **GS003**). For fieldbus versions, the software permits valve's parameterization through USB port also if the driver is connected to the central machine unit via fieldbus.

The software is available in different versions according to the driver's options (see table **GS500**):

E-SW-BASIC support: NP (USB) PS (Serial) IR (Infrared)
E-SW-FIELDBUS support: BC (CANopen) BP (PROFIBUS DP) EH (EtherCAT)
 EW (POWERLINK) EI (EtherNet/IP) EP (PROFINET)
E-SW-*/PQ support: valves with SP, SF, SL alternated control (e.g. E-SW-BASIC/PQ)

WARNING: drivers USB port is not isolated! For E-C-SB-USB/M12 cable, the use of isolator adapter is highly recommended for PC protection

WARNING: Bluetooth adapter is available only for European, USA and Canadian markets! Bluetooth adapter is certified according RED (Europe), FCC (USA) and ISED (Canada) directives

USB or Bluetooth connection

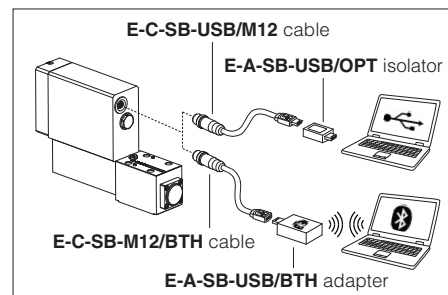

5 FIELDBUS - see tech. table **GS510**

Fieldbus allows valve direct communication with machine control unit for digital reference, valve diagnostics and settings. These execution allow to operate the valves through fieldbus or analog signals available on the terminal board.

6 GENERAL CHARACTERISTICS

Assembly position	Any position
Subplate surface finishing to ISO 4401	Acceptable roughness index, Ra ≤0,8 recommended Ra 0,4 - flatness ratio 0,01/100
MTTFd valves according to EN ISO 13849	150 years, see technical table P007
Ambient temperature range	Standard = -20°C ÷ +60°C /PE option = -20°C ÷ +60°C /BT option = -40°C ÷ +60°C
Storage temperature range	Standard = -20°C ÷ +70°C /PE option = -20°C ÷ +70°C /BT option = -40°C ÷ +70°C
Surface protection	Zinc coating with black passivation - salt spray test (EN ISO 9227) > 200 h
Compliance	Explosion proof protection, see section 10 -Flame proof enclosure "Ex d" -Dust ignition protection by enclosure "Ex t" RoHs Directive 2011/65/EU as last update by 2015/65/EU REACH Regulation (EC) n°1907/2006

7 HYDRAULIC CHARACTERISTICS - based on mineral oil ISO VG 46 at 50 °C

Valve model	QVHZA					QVKZA			
	[l/min]	3,5	12	18	35	45	65	90	
Max regulated flow	[l/min]	3,5	12	18	35	45	65	90	
Min regulated flow	[cm³/min]	15	20	30	50	60	85	100	
Regulating Δp	[bar]	4 - 6		10 - 12		15	6 - 8	10 - 12	
Max flow on port A (1)	[l/min]	40			50	55	70	100	
Max pressure	[bar]	210							
Response time 0÷100% step signal	[ms]	30					45		
Hysteresis		≤ 5 [% of the regulated max flow]							
Linearity		≤ 3 [% of the regulated max flow]							
Repeatability		≤ 1 [% of the regulated max flow]							

(1) for different Δp, the max flow is in accordance to diagrams in section 14.3

8 ELECTRICAL CHARACTERISTICS

Power supplies	Nominal : +24 VDC Rectified and filtered : $V_{RMS} = 20 \div 32 V_{MAX}$ (ripple max 10 % VPP)			
Max power consumption	35 W			
Analog input signals	Voltage: range ± 10 VDC (24 VMAX tollerant) Current: range ± 20 mA		Input impedance: $R_i > 50$ k Ω Input impedance: $R_i = 500$ Ω	
Insulation class	H (180°) Due to the occuring surface temperatures of the solenoid coils, the European standards ISO 13732-1 and EN982 must be taken into account			
Monitor outputs	Output range: voltage ± 10 Vdc @ max 5 mA current ± 20 mA @ max 500 Ω load resistance			
Enable input	Range: 0 \div 5 Vdc (OFF state), 9 \div 24 Vdc (ON state), 5 \div 9 Vdc (not accepted); Input impedance: $R_i > 10$ k Ω			
Fault output	Output range: 0 \div 24 Vdc (ON state > [power supply - 2 V] ; OFF state < 1 V) @ max 50 mA; external negative voltage not allowed (e.g. due to inductive loads)			
Pressure transducer power supply	+24VDC @ max 100 mA (E-ATRA-7 see tech table GX800)			
Alarms	Solenoid not connected/short circuit, cable break with current reference signal, over/under temperature, valve spool transducer malfunctions			
Protection degree to DIN EN60529	IP66/67 with relevant cable gland			
Duty factor	Continuous rating (ED=100%)			
Tropicalization	Tropical coating on electronics PCB			
Additional characteristics	Short circuit protection of solenoid current supply; spool position control by P.I.D. with rapid solenoid switching; protection against reverse polarity of power supply			
Electromagnetic compatibility (EMC)	According to Directive 2014/30/UE (Immunity: EN 61000-6-2; Emission: EN 61000-6-3)			
Communication interface	USB Atos ASCII coding	CANopen EN50325-4 + DS408	PROFIBUS DP EN50170-2/IEC61158	EtherCAT, POWERLINK, EtherNet/IP, PROFINET IO RT / IRT EC 61158
Communication physical layer	not insulated USB 2.0 + USB OTG	optical insulated CAN ISO11898	optical insulated RS485	Fast Ethernet, insulated 100 Base TX

Note: a maximum time of 800 ms (depending on communication type) have be considered between the driver energizing with the 24 Vdc power supply and when the valve is ready to operate. During this time the current to the valve coils is switched to zero

9 SEALS AND HYDRAULIC FLUIDS - for other fluids not included in below table, consult our technical office

Seals, recommended fluid temperature	NBR seals (standard) = -20°C \div +60°C, with HFC hydraulic fluids = -20°C \div +50°C FKM seals (/PE option) = -20°C \div +80°C HNBR seals (/BT option) = -40°C \div +60°C, with HFC hydraulic fluids = -40°C \div +50°C			
Recommended viscosity	20 \div 100 mm ² /s - max allowed range 15 \div 380 mm ² /s			
Max fluid contamination level	normal operation	ISO4406 class 18/16/13 NAS1638 class 7		see also filter section at
	longer life	ISO4406 class 16/14/11 NAS1638 class 5		www.atos.com or KTF catalog
Hydraulic fluid	Suitable seals type		Classification	Ref. Standard
Mineral oils	NBR, FKM, HNBR		HL, HLP, HLPD, HVLP, HVLPD	DIN 51524
Flame resistant without water	FKM		HFDU, HFDR	ISO 12922
Flame resistant with water (1)	NBR, HNBR		HFC	

 The ignition temperature of the hydraulic fluid must be 50°C higher than the max solenoid surface temperature

(1) Performance limitations in case of flame resistant fluids with water:

- max operating pressure = 210 bar
- max fluid temperature = 50°C

10 CERTIFICATION DATA

Valve type	QVHZA, QVKZA		
Certifications	Multicertification and Group II ATEX IECEx		
Solenoid certified code	OZA-TES		
Type examination certificate (1)	• ATEX: TUV IT 18 ATEX 068 X		• IECEx: IECEx TPS 19.0004X
Method of protection	• ATEX 2014/34/EU Ex II 2G Ex db IIC T6/T5/T4 Gb Ex II 2D Ex tb IIIC T85°C/T100°C/T135°C Db		• IECEx Ex db IIC T6/T5/T4 Gb Ex tb IIIC T85°C/T100°C/T135°C Db
Temperature class	T6	T5	T4
Surface temperature	≤ 85 °C	≤ 100 °C	≤ 135 °C
Ambient temperature (2)	-40 \div +40 °C	-40 \div +55 °C	-40 \div +70 °C
Applicable Standards	EN 60079-0: 2012+A11:2013 EN 60079-1:2014	EN 60079-31:2014	IEC 60079-0:2017 IEC 60079-1:2017-04
Cable entrance: threaded connection	M = M20x1,5		

(1) The type examiner certificates can be downloaded from www.atos.com

(2) The driver and solenoids are certified for minimum ambient temperature -40°C.

In case the complete valve must withstand with minimum ambient temperature -40°C, select **/BT** in the model code.

 **WARNING: service work performed on the valve by the end users or not qualified personnel invalidates the certification**

11 CABLE SPECIFICATION AND TEMPERATURE - Power supply and grounding cables have to comply with following characteristics:

Power supply and signals: section of wire = 1,0 mm ²	Grounding: section of external ground wire = 4 mm ²
--	---

11.1 Cable temperature

The cable must be suitable for the working temperature as specified in the "safety instructions" delivered with the first supply of the products.

Max ambient temperature [°C]	Temperature class	Max surface temperature [°C]	Min. cable temperature [°C]
40 °C	T6	85 °C	80 °C
55 °C	T5	100 °C	90 °C
70 °C	T4	135 °C	110 °C

12 CABLE GLANDS

Cable glands with threaded connections M20x1,5 for standard or armoured cables have to be ordered separately, see tech table **KX800**

Note: a Loctite sealant type 545, should be used on the cable gland entry threads

13 ELECTRONIC OPTIONS

I = It provides 4 ÷ 20 mA current reference signal, instead of the standard ±10 V_{DC}. Input signal can be reconfigured via software selecting between voltage and current, within a maximum range of ±10 V_{DC} or ±20 mA. It is normally used in case of long distance between the machine control unit and the valve or where the reference signal can be affected by electrical noise; the valve functioning is disabled in case of reference signal cable breakage.

14 DIAGRAMS - based on mineral oil ISO VG 46 at 50 °C

14.1 Regulation diagrams

- 1 = QVHZA-*-06/3
- 2 = QVHZA-*-06/12
- 3 = QVHZA-*-06/18
- 4 = QVHZA-*-06/36
- 5 = QVHZA-*-06/45
- 6 = QVKZA-*-10/65
- 7 = QVKZA-*-10/90

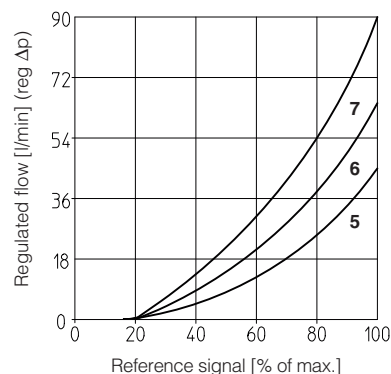
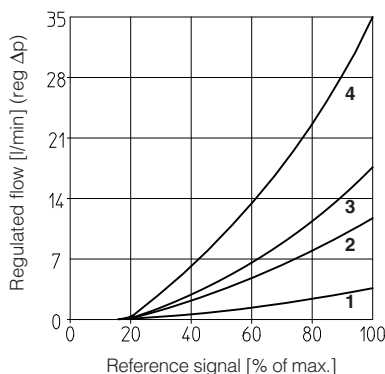

14.2 Regulated flow/outlet pressure diagrams
with inlet pressure = 210 bar

- 1 = QVHZA
- 2 = QVKZA

Dotted line for 3-way versions

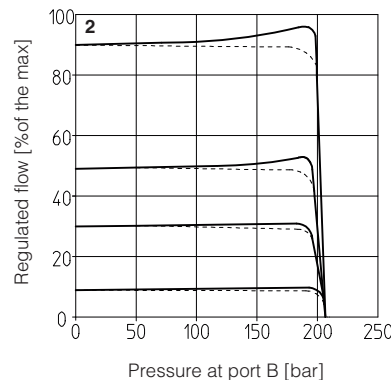
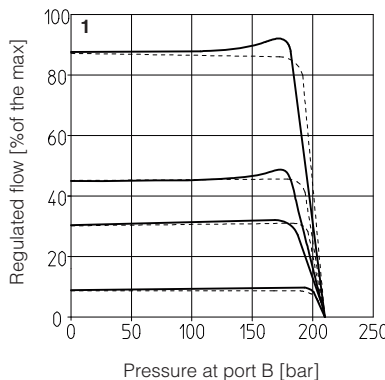

14.3 Flow A → P/Δp diagrams
3-way configuration

- 1 = QVHZA-*-06/3
- 2 = QVHZA-*-06/12
- 3 = QVHZA-*-06/18
- 4 = QVHZA-*-06/36
- 5 = QVHZA-*-06/45
- 6 = QVKZA-*-10/65
- 7 = QVKZA-*-10/90

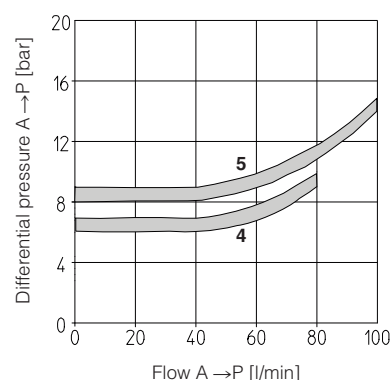
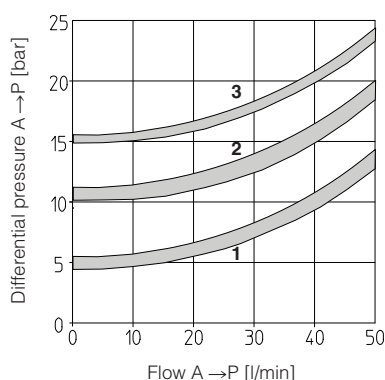

15 POWER SUPPLY AND SIGNALS SPECIFICATIONS

Generic electrical output signals of the valve (e.g. fault or monitor signals) must not be directly used to activate safety functions, like to switch-ON/OFF the machine's safety components, as prescribed by the European standards (Safety requirements of fluid technology systems and components-hydraulics, EN-982).

15.1 Power supply (V+ and V0)

The power supply must be appropriately stabilized or rectified and filtered: apply at least a 10000 $\mu\text{F}/40\text{ V}$ capacitance to single phase rectifiers or a 4700 $\mu\text{F}/40\text{ V}$ capacitance to three phase rectifiers.

 A safety fuse is required in series to each power supply: 2,5 A time lag fuse.

15.2 Power supply for driver's logic and communication (VL+ and VL0)

The power supply for driver's logic and communication must be appropriately stabilized or rectified and filtered: apply at least a 10000 $\mu\text{F}/40\text{ V}$ capacitance to single phase rectifiers or a 4700 $\mu\text{F}/40\text{ V}$ capacitance to three phase rectifiers.

The separate power supply for driver's logic on pin 3 and 4, allow to remove solenoid power supply from pin 1 and 2 maintaining active the diagnostics, USB and fieldbus communications.

 A safety fuse is required in series to each driver's logic and communication power supply: 500 mA fast fuse.

15.3 Flow reference input signal (Q_INPUT+)

The driver controls in closed loop the valve spool position proportionally to the external reference input signal.

Reference input signal is factory preset according to selected valve code, defaults are $\pm 10\text{ VDC}$ for standard and $4 \div 20\text{ mA}$ for /I option.

Input signal can be reconfigured via software selecting between voltage and current, within a maximum range of $\pm 10\text{ VDC}$ or $\pm 20\text{ mA}$.

Drivers with fieldbus interface can be software set to receive reference signal directly from the machine control unit (fieldbus reference). Analog reference input signal can be used as on-off commands with input range $0 \div 24\text{VDC}$.

15.4 Flow monitor output signal (Q_MONITOR)

The driver generates an analog output signal proportional to the actual spool position of the valve; the monitor output signal can be software set to show other signals available in the driver (e.g. analog reference, fieldbus reference, pilot spool position).

Monitor output signal is factory preset according to selected valve code, defaults are $\pm 10\text{ VDC}$ for standard and $4 \div 20\text{ mA}$ for /I option.

Output signal can be reconfigured via software selecting between voltage and current, within a maximum range of $\pm 10\text{ VDC}$ or $\pm 20\text{ mA}$.

15.5 Enable input signal (ENABLE)

To enable the driver, supply a 24 Vdc on pin 5: Enable input signal allows to enable/disable the current supply to the solenoid, without removing the electrical power supply to the driver; it is used to activate the communication and the other driver functions when the valve must be disabled for safety reasons. This condition **does not comply** with norms IEC 61508 and ISO 13849.

Enable input signal can be used as generic digital input by software selection.

15.6 Fault output signal (FAULT)

Fault output signal indicates fault conditions of the driver (solenoid short circuits/not connected, reference signal cable broken for $4 \div 20\text{ mA}$ input, spool position transducer cable broken, etc.). Fault presence corresponds to 0 VDC, normal working corresponds to 24 VDC.

Fault status is not affected by the Enable input signal. Fault output signal can be used as digital output by software selection.

16 TERMINAL BOARD OVERVIEW

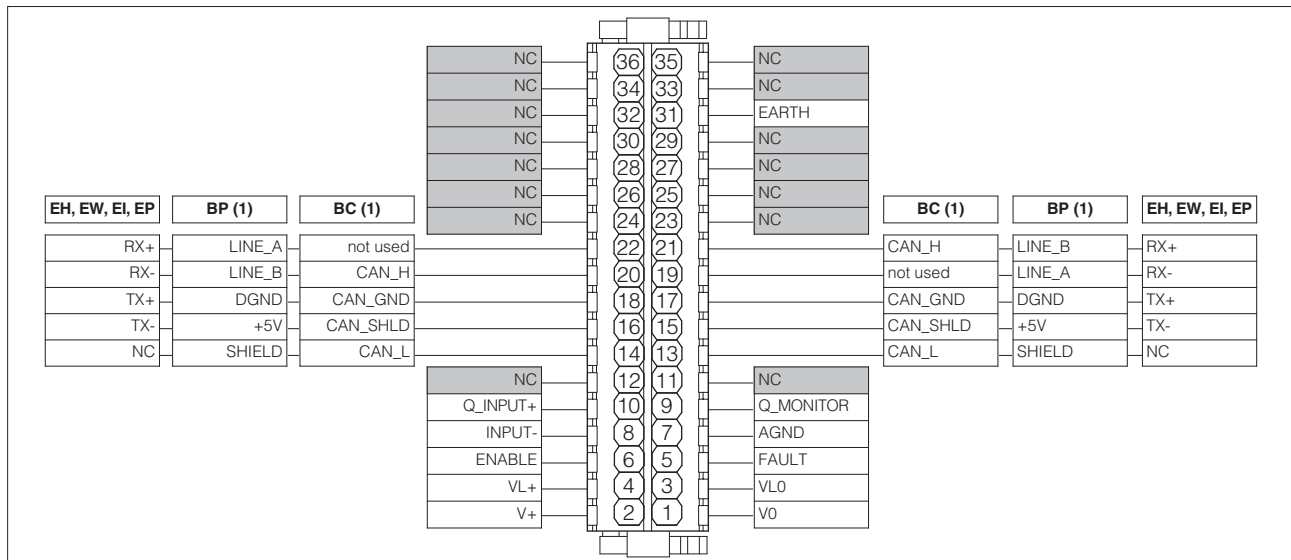

(1) For BC and BP executions the fieldbus connections have an internal pass-through connection

17 ELECTRONIC CONNECTIONS

17.1 Main connections signals

CABLE ENTRANCE	PIN	SIGNAL	TECHNICAL SPECIFICATIONS	NOTES
A	1	V0	Power supply 0 Vdc	Gnd - power supply
	2	V+	Power supply 24 Vdc	Input - power supply
	3	VL0	Power supply 0 Vdc for driver's logic and communication	Gnd - power supply
	4	VL+	Power supply 24 Vdc for driver's logic and communication	Input - power supply
	5	FAULT	Fault (0 Vdc) or normal working (24 Vdc), referred to VL0	Output - on/off signal
	6	ENABLE	Enable (24 Vdc) or disable (0 Vdc) the driver, referred to VL0	Input - on/off signal
	7	AGND	Analog ground	Gnd - analog signal
	8	INPUT-	Negative reference input signal for INPUT+	Input - analog signal
	9	Q_MONITOR	Flow monitor output signal: ± 10 Vdc / ± 20 mA maximum range, referred to AGND Defaults are: ± 10 Vdc for standard and $4 \div 20$ mA for /I option	Output - analog signal Software selectable
	10	Q_INPUT+	Flow reference input signal: ± 10 Vdc / ± 20 mA maximum range, referred to AGND Defaults are: ± 10 Vdc for standard and $4 \div 20$ mA for /I option	Input - analog signal Software selectable
	31	EARTH	Internally connected to driver housing	

17.2 USB connector - M12 - 5 pin always present

CABLE ENTRANCE	PIN	SIGNAL	TECHNICAL SPECIFICATIONS
B	1	+5V_USB	Power supply
	2	ID	Identification
	3	GND_USB	Signal zero data line
	4	D-	Data line -
	5	D+	Data line +

Driver view

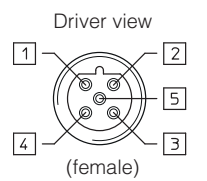

(female)

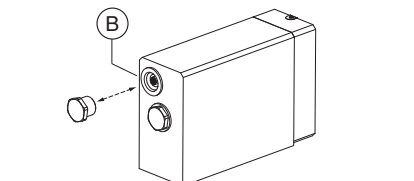

17.3 BC fieldbus execution connections

CABLE ENTRANCE	PIN	SIGNAL	TECHNICAL SPECIFICATIONS
C1	14	CAN_L	Bus line (low)
	16	CAN_SHLD	Shield
	18	CAN_GND	Signal zero data line
	20	CAN_H	Bus line (high)
	22	not used	Pass-through connection (1)

CABLE ENTRANCE	PIN	SIGNAL	TECHNICAL SPECIFICATIONS
C2	13	CAN_L	Bus line (low)
	15	CAN_SHLD	Shield
	17	CAN_GND	Signal zero data line
	19	not used	Pass-through connection (1)
	21	CAN_H	Bus line (high)

(1) Pin 19 and 22 can be fed with external +5V supply of CAN interface

17.4 BP fieldbus execution connections

CABLE ENTRANCE	PIN	SIGNAL	TECHNICAL SPECIFICATIONS
C1	14	SHIELD	
	16	+5V	Power supply
	18	DGND	Data line and termination signal zero
	20	LINE_B	Bus line (low)
	22	LINE_A	Bus line (high)

CABLE ENTRANCE	PIN	SIGNAL	TECHNICAL SPECIFICATIONS
C2	13	SHIELD	
	15	+5V	Power supply
	17	DGND	Data line and termination signal zero
	19	LINE_A	Bus line (high)
	21	LINE_B	Bus line (low)

17.5 EH fieldbus execution connections

CABLE ENTRANCE	PIN	SIGNAL	TECHNICAL SPECIFICATIONS
C1 (input)	14	NC	do not connect
	16	TX-	Transmitter
	18	TX+	Transmitter
	20	RX-	Receiver
	22	RX+	Receiver

CABLE ENTRANCE	PIN	SIGNAL	TECHNICAL SPECIFICATIONS
C2 (output)	13	NC	do not connect
	15	TX-	Transmitter
	17	TX+	Transmitter
	19	RX-	Receiver
	21	RX+	Receiver

CABLE ENTRANCE OVERVIEW

Cables entrance description:

- (A) main connections
- (B) USB connector always present (factory plugged)
- (C1) fieldbus (input)
- (C2) fieldbus (output)
- (D1) pressure transducer 1
- (D2) pressure transducer 2
- (P) threaded plug

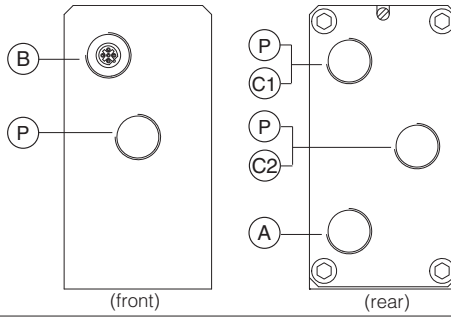

TERMINAL BOARD AND FIELDBUS TERMINATOR

Remove the 4 screws of driver's rear cover to access terminal board and fieldbus terminator

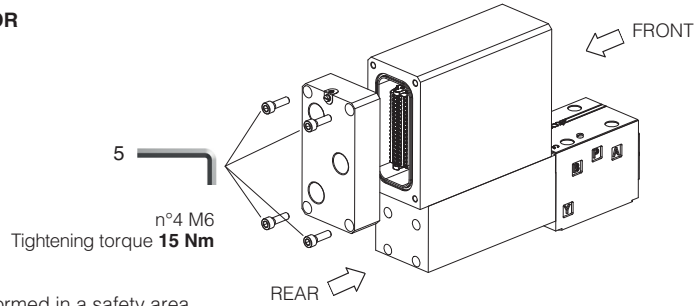

WARNING: the above operation must be performed in a safety area

Terminal board - see section 17

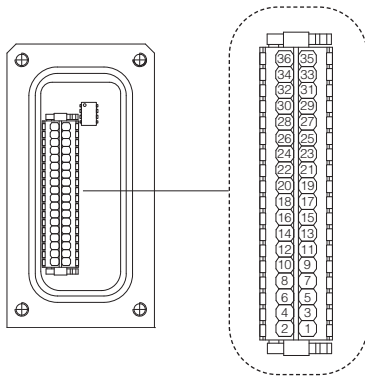

Fieldbus terminator only for BC and BP executions (1)

BC - CANopen setting:		Termination enabled
Switch 1	OFF	<input type="checkbox"/> 1
Switch 2	OFF	<input checked="" type="checkbox"/> 2
Switch 3	OFF	<input type="checkbox"/> 3
Switch 4	ON	<input checked="" type="checkbox"/> 4

BP - PROFIBUS DP setting:		Termination enabled
Switch 1	ON	<input checked="" type="checkbox"/> 1
Switch 2	ON	<input checked="" type="checkbox"/> 2
Switch 3	ON	<input type="checkbox"/> 3
Switch 4	OFF	<input checked="" type="checkbox"/> 4

USB CONNECTOR

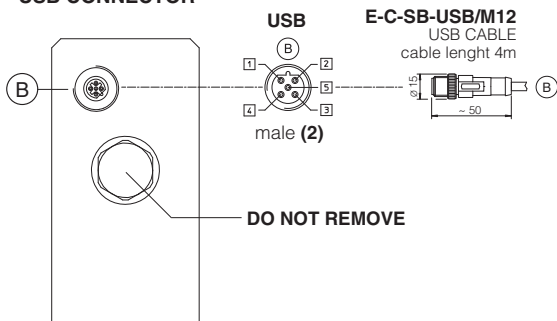

METALLIC PROTECTION CAP - supplied with the valves 24

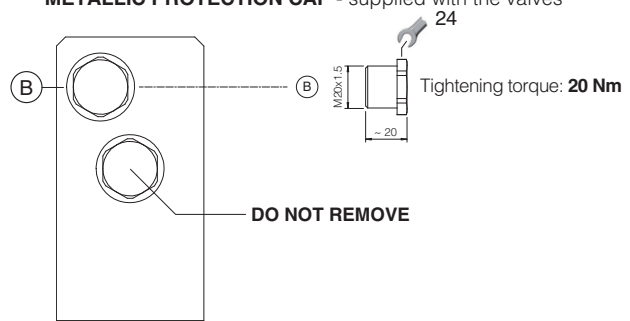

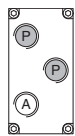
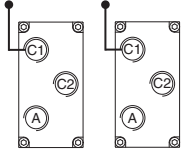
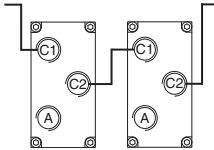

(1) Drivers with BC and BP fieldbus interface are delivered by default 'Not Terminated'. All switches are set OFF
 (2) Pin layout always referred to driver's view

18.1 Cable glands and threaded plug

Communication interfaces	To be ordered separately				Cable entrance overview	Notes
	Cable gland quantity	entrance	Threaded plug quantity	entrance		
NP	1	A	none	none		Cable entrance A is open for costumers Cable entrance P are factory plugged
BC, BP, EH, EW, EI, EP "via stub" connection	2	C1 A	1	C2		Cable entrance A, C1, C2 are open for costumers
BC, BP, EH, EW, EI, EP "daisy chain" connection	3	C1 C2 A	none	none		Cable entrance A, C1, C2 are open for costumers

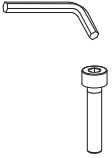
19 FASTENING BOLTS AND SEALS

	QVHZA	QVKZA
	<p>Fastening bolts: 4 socket head screws M5x50 class 12.9 Tightening torque = 8 Nm</p>	<p>Fastening bolts: 4 socket head screws M6x40 class 12.9 Tightening torque = 15 Nm</p>
	<p>Seals: 4 OR 108; Diameter of ports A, B, P, T: Ø 7,5 mm (max)</p>	<p>Seals: 5 OR 2050; Diameter of ports A, B, P, T: Ø 11,2 mm (max)</p>

20 INSTALLATION DIMENSIONS [mm]

QVHZA-TES

ISO 4401: 2005

Mounting surface: 4401-03-02-0-05 (see tab. P005)

Mass [kg]	
QVHZA-TES	7,2

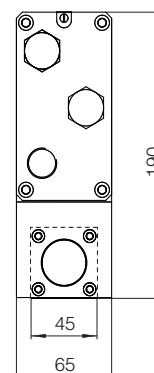
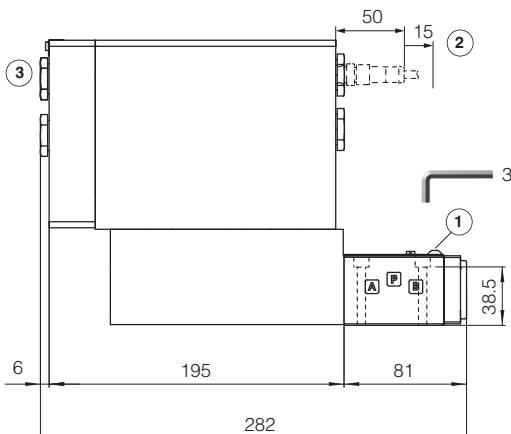

QVKZA-TES

ISO 4401: 2005

Mounting surface: 4401-05-04-0-05 (see tab. P005)

Mass [kg]	
QVKZA	9

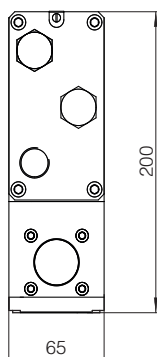
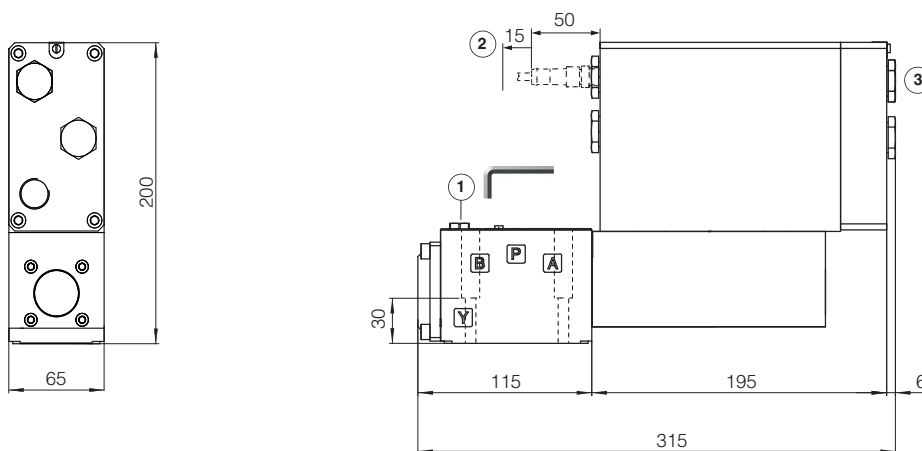

- ① = Air bleed off
- ② = Space to remove the connectors
- ③ = The dimensions of cable glands must be considered (see tech table **KX800**)

21 RELATED DOCUMENTATION

X010	Basics for electrohydraulics in hazardous environments	GS500	Programming tools
X020	Summary of Atos ex-proof components certified to ATEX, IECEx, EAC, PESO	GS510	Fieldbus
FX900	Operating and maintenance information for ex-proof proportional valves	KX800	Cable glands for ex-proof valves
		P005	Mounting surfaces for electrohydraulic valves