

Digital E-BM-TEB/LEB drivers

DIN-rail format, for proportional valves with one or two LVDT transducers

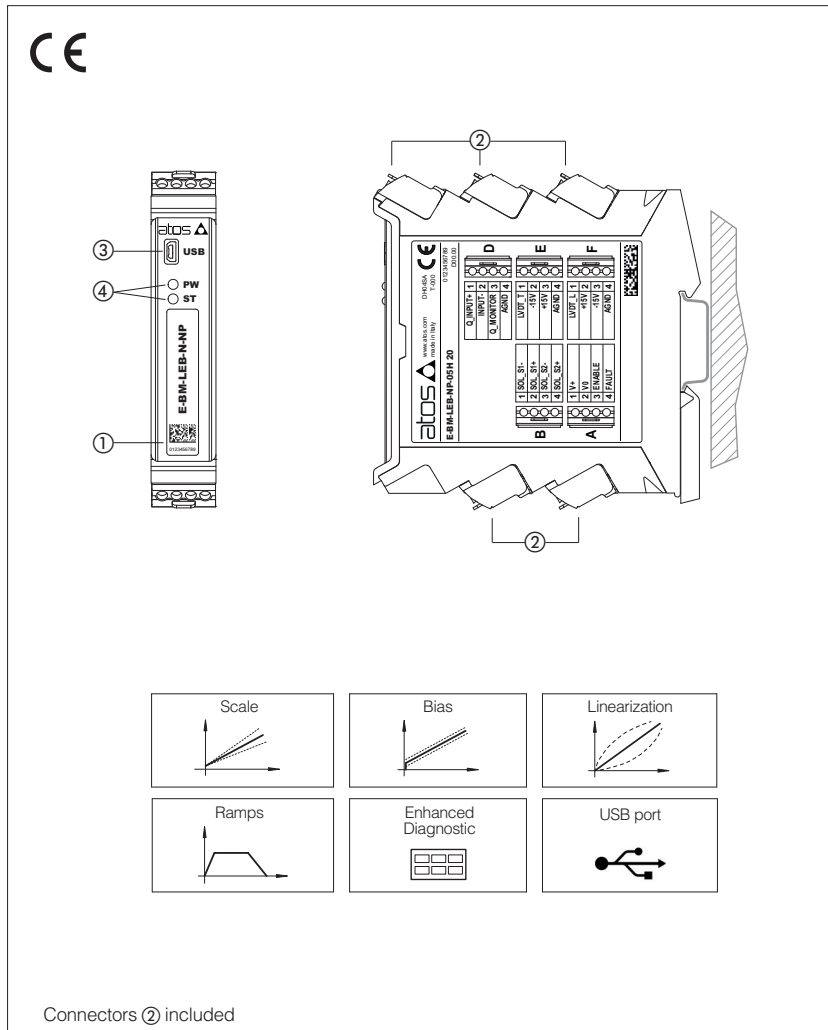

E-BM-TEB/LEB

Digital drivers ① control in closed loop the position of the spool or poppet of direct and pilot operated proportional valves, according to the electronic reference input signal.

TEB execution controls direct operated directional/flow valves with one LVDT transducer.

LEB execution controls pilot operated directional valves with two LVDT transducers.

Atos PC software allows to customize the driver configuration to the specific application requirements.

Electrical Features:

- 5 fast plug-in connectors ②
- Mini USB port ③ always present
- 2 leds for diagnostics ④ (see 5.1)
- Electrical protection against reverse polarity of power supply
- Operating temperature range: $-20 \div +60 \text{ }^\circ\text{C}$
- Plastic box with IP20 protection degree and standard DIN-rail mounting
- CE mark according to EMC directive

Software Features:

- Intuitive graphic interface
- Setting of valve's functional parameters: bias, scale, ramps, dither
- Linearization function for hydraulic regulation
- Setting of PID gains
- Selection of analog IN / OUT range
- Complete diagnostic of driver status
- Internal oscilloscope function
- In field firmware update through USB port

1 MODEL CODE

E-BM	-	TEB	-	N	-	NP	-	01H	*	/	*	*	/	*
Off-board electronic driver in DIN rail format TEB = digital basic driver, for valves with one LVDT transducer LEB = digital basic driver, for valves with two LVDT transducers Alternated P/Q control: N = none									Set code (see section 6) Series number Options , see section 5: A = max current limitation for Ex-proof valves C = current feedback $4 \div 20 \text{ mA}$ for LVDT transducers only in combination with option A I = current reference input and monitor $4 \div 20 \text{ mA}$ (omit for voltage reference and monitor input $\pm 10 \text{ VDC}$) - = omit for direct valves and for pilot operated valves with two LVDT transducers P = for pilot operated valves with one LVDT transducer (only for TEB)					
Fieldbus interface , USB port always present: NP = Not Present									01H = for single solenoid proportional valves 05H = for double solenoid proportional valves (only for TEB)					

2 BLOCK DIAGRAM EXAMPLE

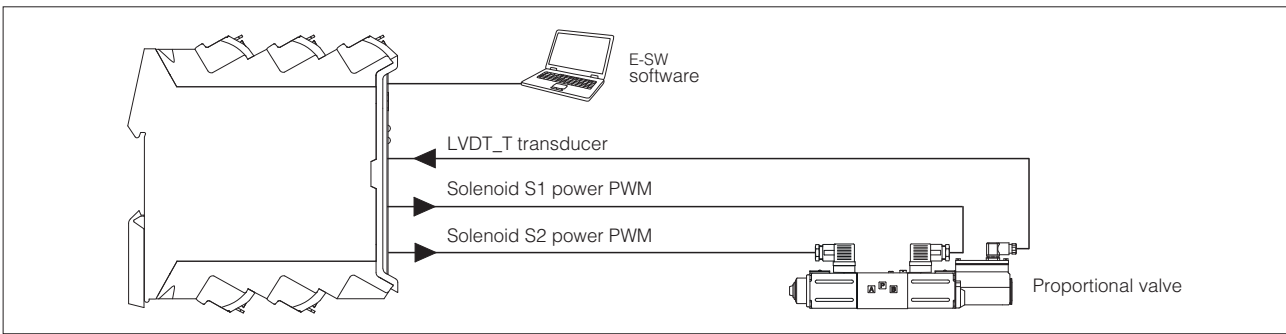

3 VALVES RANGE

Valves	Directional			Flow	Directional	Cartridge
Industrial Tech table	DHZO-T, DKZOR-T F165, F168	DLHZO-T, DLKZOR-T F180	DPZO-T F172	QVHZO-T, QVKZOR-T F412	DPZO-L F175, F178	LIQZP-L F330, F340
Ex-proof Tech table	DHZA-T, DKZA-T FX120	DLHZA-T, DLKZA-T FX140	DPZA-T FX220	QVHZA-T, QVKZA-T FX420	-	LIQZA-L FX350, FX370
Driver model	E-BM-TEB				E-BM-LEB	

4 MAIN CHARACTERISTICS

Power supply (see 7.1)	Nominal : +24 V _{DC} Rectified and filtered : V _{RMS} = 20 ÷ 32 V _{MAX} (ripple max 10 % V _{PP})
Max power consumption	50 W
Current supplied to solenoids	I _{MAX} = 3.0 A for standard driver I _{MAX} = 2.5 A for ex-proof driver (/A option)
Analog input signal (see 7.2)	Voltage: range ±10 V _{DC} (24 V _{MAX} tollerant) Input impedance: R _i > 50 kΩ Current: range ±20 mA Input impedance: R _i = 500 Ω
Monitor output (see 7.3)	Output range: voltage ±10 V _{DC} @ max 5 mA current ±20 mA @ max 500 Ω load resistance
Enable input (see 7.4)	Range: 0 ÷ 5 V _{DC} (OFF state), 9 ÷ 24 V _{DC} (ON state), 5 ÷ 9 V _{DC} (not accepted); Input impedance: R _i > 10 kΩ
Fault output (see 7.5)	Output range: 0 ÷ 24 V _{DC} (ON state > [power supply - 2 V]; OFF state < 1 V) @ max 50 mA; external negative voltage not allowed (e.g. due to inductive loads)
Alarms	Solenoid not connected/short circuit, cable break with current reference signal, over/under temperature, valve spool transducer malfunctions, alarms history storage function
Format	Plastic box ; IP20 protection degree ; L 35 - H 7,5 mm DIN-rail mounting as per EN60715
Operating temperature	-20 ÷ +60 °C (storage -25 ÷ +85 °C)
Mass	Approx. 300 g
Additional characteristics	2 leds for diagnostic; protection against reverse polarity of power supply
Compliance	CE according to EMC directive 2014/30/EU (Immunity: EN 61000-6-2; Emission: EN 61000-6-3) RoHS Directive 2011/65/EU as last update by 2015/65/EU REACH Regulation (EC) n°1907/2006
Communication interface	USB Atos ASCII coding
Communication physical layer	USB 2.0 + USB OTG not insulated
Recommended wiring cable	LiYCY shielded cables: 0,5 mm ² max 50 m for logic - 1,5 mm ² max 50 m for power supply Note: for transducers wiring cable please consult the transducers datasheet
Max conductor size (see 11)	2,5 mm ²

Note: a maximum time of 400 ms have be considered between the driver energizing with the 24 V_{DC} power supply and when the valve is ready to operate. During this time the current to the valve coils is switched to zero.

5 CONNECTIONS AND LEDS

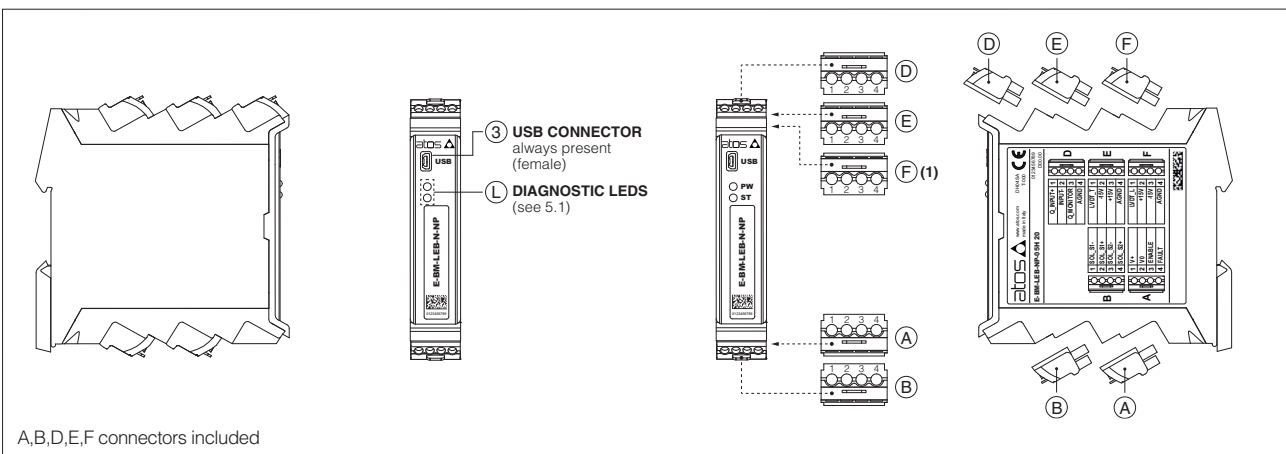

(1) F connector is available only for LEB

5.1 Diagnostic LEDs

Two leds show driver operative conditions for immediate basic diagnostics. Please refer to the driver user manual for detailed information.

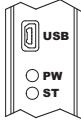
LEDS	DESCRIPTION		
PW	OFF = Power supply OFF	ON = Power supply ON	
ST	OFF = Fault present	ON = No fault	

5.2 Connectors - 4 pin

CONNECTOR	PIN	SIGNALS	TECHNICAL SPECIFICATIONS	NOTES
A	A1	V+	Power supply 24 Vdc (see 7.1)	Input - power supply
	A2	V0	Power supply 0 Vdc (see 7.1)	Gnd - power supply
	A3	ENABLE	Enable (24 Vdc) or disable (0 Vdc) the controller, referred to V0 (see 7.4)	Input - on/off signal
	A4	FAULT	Fault (0 Vdc) or normal working (24 Vdc), referred to V0 (see 7.5)	Output - on/off signal
B	B1	SOL_S1-	Negative current to solenoid S1	Output - power PWM
	B2	SOL_S1+	Positive current to solenoid S1	Output - power PWM
	B3	SOL_S2-	Negative current to solenoid S2	Output - power PWM
	B4	SOL_S2+	Positive current to solenoid S2	Output - power PWM
D	D1	Q_INPUT+	Flow reference input signal: ± 10 Vdc / ± 20 mA maximum range Default are ± 10 Vdc for standard and $4 \div 20$ mA for /I option (see 7.2)	Input - analog signal Software selectable
	D2	INPUT-	Negative reference input signal for Q_INPUT+	Input - analog signal
	D3	Q_MONITOR	Flow monitor output signal: ± 10 Vdc / ± 20 mA maximum range, referred to AGND Default are ± 10 Vdc for standard and $4 \div 20$ mA for /I option (see 7.3)	Output - analog signal Software selectable
	D4	AGND	Common gnd for monitor output	Common gnd
E	E1	LVDT_T	Direct valve or pilot valve position transducer signal (see 7.6)	Input - analog signal
	E2	-15V	Direct valve or pilot valve stage position transducer power supply -15V	Output power supply
	E3	+15V	Direct valve or pilot valve tage position transducer power supply +15V	Output power supply
	E4	AGND	Common gnd for transducer power	Common gnd
F ⁽¹⁾	F1	LVDT_L	Main stage valve position transducer signal (see 7.6)	Input - analog signal
	F2	-15V	Main stage valve position transducer power supply -15V	Output power supply
	F3	+15V	Main stage valve position transducer power supply +15V	Output power supply
	F4	AGND	Common gnd for transducer power	Common gnd

(1) F connector is available only for LEB

6 SET CODE

The basic calibration of electronic driver is factory preset, according to the proportional valve to be coupled. These pre-calibrations are identified by the set code at the end of driver's model code (see section [1](#)). For correct set code selection, please include in the driver order also the complete code of the coupled proportional valve. For further information about set code, please contact Atos technical office.

7 POWER SUPPLY AND SIGNALS SPECIFICATIONS

Atos digital drivers are CE marked according to the applicable directives (e.g. Immunity and Emission EMC Directive).

Installation, wirings and start-up procedures must be performed according to the general prescriptions shown in the user manuals included in the E-SW-* programming software.

Generic electrical output signals of the valve (e.g. fault or monitor signals) must not be directly used to activate safety functions, like to switch-ON/OFF the machine's safety components, as prescribed by the European standards (Safety requirements of fluid technology systems and components-hydraulics, ISO 4413).

7.1 Power supply (V+ and V0)

The power supply (pin A1 and A2) must be appropriately stabilized or rectified and filtered: apply at least a 10000 μ F/40 V capacitance to single phase rectifiers or a 4700 μ F/40 V capacitance to three phase rectifiers.

 A safety fuse is required in series to each power supply: 2,5 A time lag fuse.

7.2 Flow reference input signal (Q_INPUT+)

The driver is designed to receive an analog reference input signal (pin D1) for the valve's spool position.

Reference input signal is factory preset according to selected valve code, defaults are ± 10 Vdc for standard and $4 \div 20$ mA for /I option.

Input signal can be reconfigured via software selecting between voltage and current, within a maximum range of ± 10 Vdc or ± 20 mA.

7.3 Flow monitor output signal (Q_MONITOR)

The driver generates an analog output signal (pin D3) proportional to the actual spool position; the monitor output signal can be software set to show other signals available in the driver (e.g. analog reference, valve spool position).

Monitor output signal is factory preset according to selected valve code, defaults are ± 10 Vdc for standard and $4 \div 20$ mA for /I option.

Output signal can be reconfigured via software selecting between voltage and current, within a maximum range of ± 10 Vdc or ± 20 mA.

7.4 Enable input signal (ENABLE)

To enable the driver, supply 24 Vdc on pin A3: Enable input signal allows to enable/disable the current supply to the solenoid, without removing the electrical power supply to the driver; it is used to active the communication and the other driver functions when the valve must be disabled for safety reasons. This condition **does not comply** with norms IEC 61508 and ISO 13849.

7.5 Fault output signal (FAULT)

Fault output signal (pin A4) indicates fault conditions of the driver (solenoid short circuits/not connected, reference or transducer signal cable broken, maximum error exceeded, etc.). Fault presence corresponds to 0 Vdc, normal working corresponds to 24 Vdc.

Fault status is not affected by the status of the Enable input signal.

7.6 Main stage and direct or pilot position transducer input signals (LVDT_L and LVDT_T)

Main stage (LVDT_L pin F1) and direct or pilot (LVDT_T pin E1) position transducer integrated to the valve have to be directly connected to the driver using ± 15 Vdc supply output available at pin F2, F3 and pin E2, E3.

Note: transducer input signals working range is ± 10 Vdc for standard or $4 \div 20$ mA for /C option and **cannot** be reconfigured via software (input signals setting depends to the driver set code).

7.7 Possible combined options: /AC, /AI, /ACI

8 VALVE SETTINGS AND PROGRAMMING TOOLS

Valve's functional parameters and configurations, can be easily set and optimized using Atos E-SW programming software connected via USB/Bluetooth to the digital driver.

For fieldbus versions, the software permits valve's parameterization through USB/Bluetooth also if the driver is connected to the central machine unit via fieldbus.

The software is available in different versions according to the driver's options (see table **GS500**):

E-SW-BASIC support: NP (USB) IL (IO-Link) PS (Serial) IR (Infrared)

E-SW-FIELDBUS support: BC (CANopen) BP (PROFIBUS DP) EH (EtherCAT)

EW (POWERLINK) EI (EtherNet/IP) EP (PROFINET)

E-SW-*/PQ support: valves with SP, SF, SL alternated control (e.g. E-SW-BASIC/PQ)

 **WARNING: drivers USB port is not isolated!** For E-C-SB-USB/BM cable, the use of isolator adapter is highly recommended for PC protection

 **WARNING:** see tech table **GS500** for the list of countries where the Bluetooth adapter has been approved

Free programming software, web download:

E-SW-BASIC web download = software can be downloaded upon web registration at www.atos.com; service and USB memory stick not included
Upon web registration user receive via email the Activation Code (software free license) and login data to access Atos Download Area

USB memory stick of programming software, to be ordered separately:

E-SW-*/PQ USB memory stick first supply = software has to be activated via web registration at www.atos.com; 1 year service included
Upon web registration user receive via email the Activation Code (software license) and login data to access Atos Download Area

E-SW-*/N/PQ USB memory stick next supplies = only for supplies after the first; service not included, web registration not allowed
Software has to be activated with Activation Code received upon first supply web registration

Atos Download Area: direct access to latest releases of E-SW software, manuals, USB drivers and fieldbus configuration files at www.atos.com

USB Adapters, Cables and Terminators, can be ordered separately

9 MAIN SOFTWARE PARAMETER SETTINGS

For detailed descriptions of settings, wirings and installation procedures, please refer to the user manual included in the E-SW programming software:

E-MAN-BM-LEB - user manual for **E-BM-TEB** and **E-BM-LEB** digital drivers

USB or Bluetooth connection

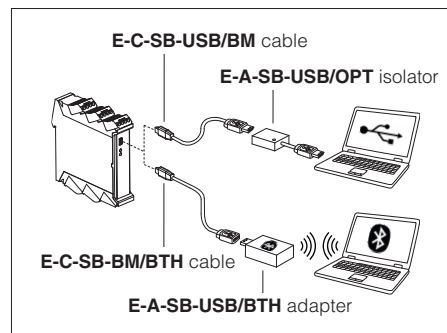

10 OVERALL DIMENSIONS [mm]

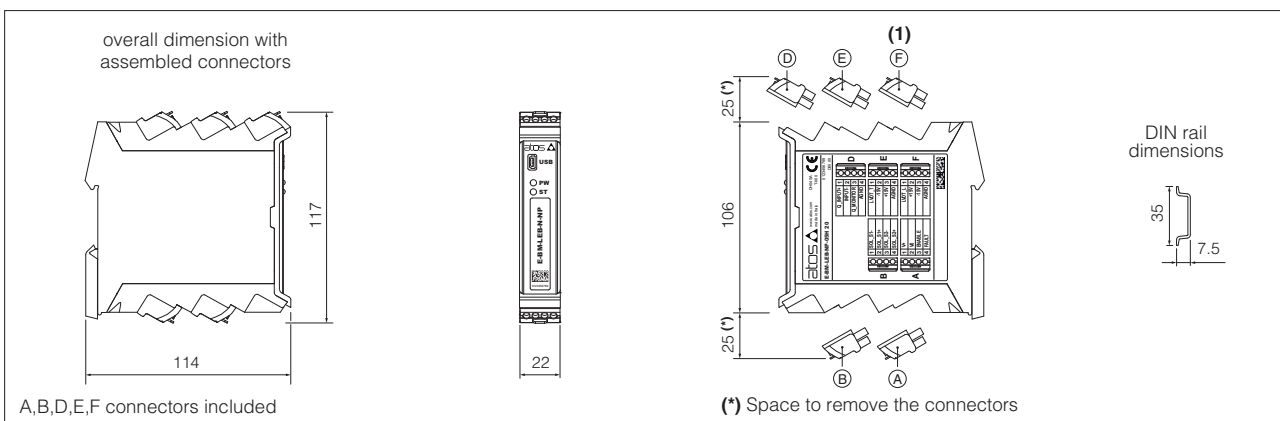

(1) F connector is available only for LEB

11 INSTALLATION

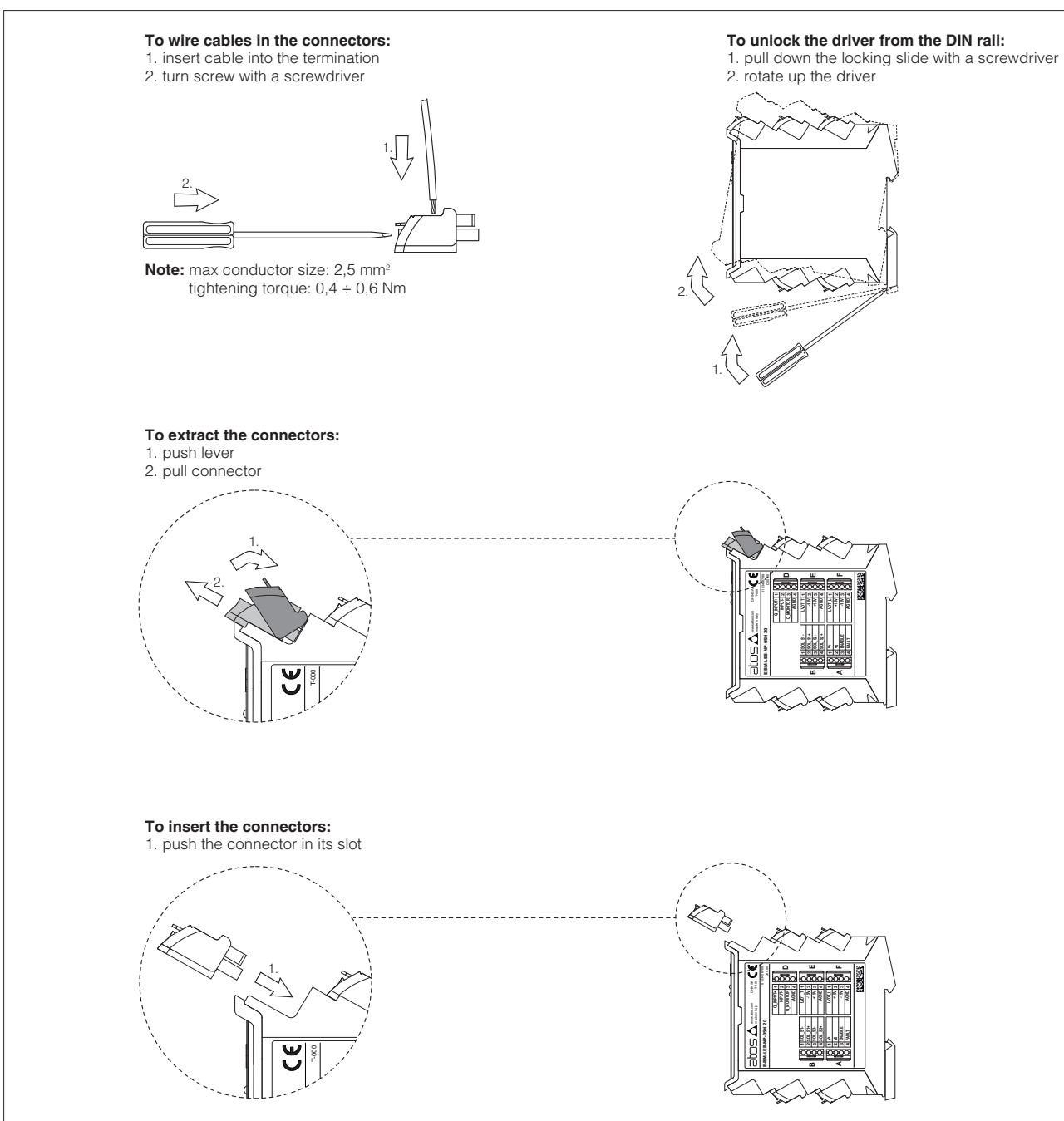

Note: all connectors are supplied with a mechanical coding. This feature ensures a unique insertion of each connector in the own slot. (e.g. connector A can not be inserted into connector slot of B,D,E,F)