

# Digital proportional directional valves high performance

direct, with on-board driver, LVDT transducer and positive spool overlap

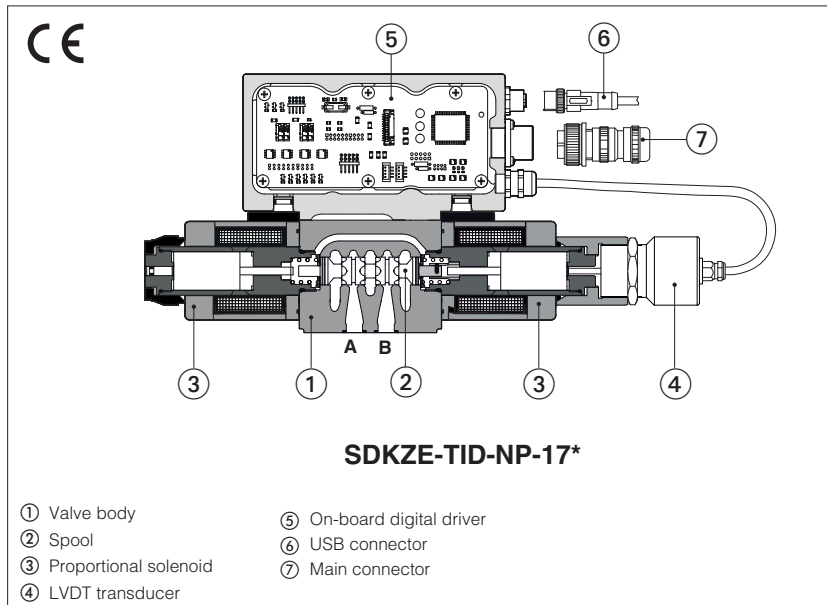

### SDHZE-TID, SDKZE-TID

Digital high performances proportional directional valves, direct, with LVDT position transducer and positive spool overlap for directional controls and not compensated flow regulations.

**TID** on board digital driver performs the valve's hydraulic regulation according to the reference signal sent to the 7 pin main connector.

The software setting of functional parameters can be performed via USB port.

The LVDT transducer grants high regulation accuracy and response sensitivity.

With de-energized proportional solenoids, the mechanical central position of the spool is performed by centering springs.

#### SDHZE:

Size: **06** - ISO 4401

4/3 and 4/2 way

Max flow: **80 l/min**

Max pressure: **350 bar**

#### SDKZE:

Size: **10** - ISO 4401

4/3 and 4/2 way

Max flow: **180 l/min**

Max pressure: **315 bar**

## 1 MODEL CODE

<b>SDHZE</b>	-	<b>TID</b>	-	<b>NP</b>	-	<b>0</b>	-	<b>71</b>	-	<b>S</b>	-	<b>5</b>	/	<b>*</b>	-	<b>*</b>	/	<b>*</b>	
<b>SDHZE</b> = size 06 <b>SDKZE</b> = size 10																			
<b>TID</b> = on-board digital driver and LVDT transducer																			
<b>Fieldbus interfaces</b> , USB port always present: <b>NP</b> = Not present																			
<b>Valve size</b> ISO 4401: <b>0</b> = 06 <b>1</b> = 10																			
																		<b>Series number</b>	
																		<b>Seals material</b> , see section <a href="#">7</a> : - = NBR PE = FKM	
																		<b>Options</b> , see section <a href="#">9</a> : <b>B</b> = on-board digital driver connections and LVDT position transducer at side of port A	

### Configuration: Standard      Option /B

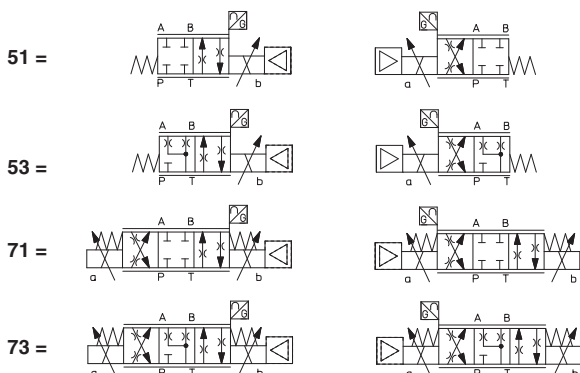

<b>Spool size:</b>	<b>3</b> (L,S,D)	<b>5</b> (L,S,D)
SDHZE =	18	28
SDKZE =	45	75

Nominal flow (l/min) at  $\Delta p$  10 bar P-T

### Spool type, regulating characteristics:

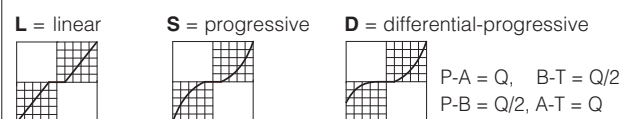

## 2 GENERAL NOTES

Atos digital proportionals valves are CE marked according to the applicable directives (e.g. Immunity and Emission EMC Directive). Installation, wirings and start-up procedures must be performed according to the general prescriptions shown in the user manuals included in the E-SW-\* programming software.

### 3 VALVE SETTINGS AND PROGRAMMING TOOLS

Valve's functional parameters and configurations, can be easily set and optimized using Atos E-SW-BASIC programming software connected via USB port to the digital driver.

**WARNING: drivers USB port is not isolated!** For E-C-SB-USB/M12 cable, the use of isolator adapter is highly recommended for PC protection

### USB or Bluetooth connection

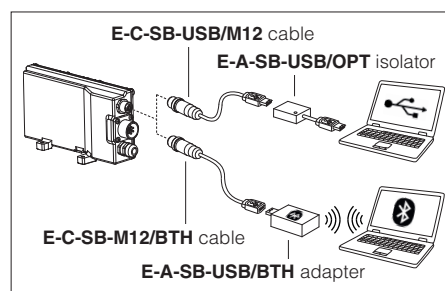

### 4 GENERAL CHARACTERISTICS

Assembly position	Any position
Subplate surface finishing to ISO 4401	Acceptable roughness index: Ra ≤ 0,8, recommended Ra 0,4 – Flatness ratio 0,01/100
MTTFd valves according to EN ISO 13849	150 years, see technical table P007
Ambient temperature range	<b>Standard</b> = -20°C ÷ +60°C <b>/PE option</b> = -20°C ÷ +60°C
Storage temperature range	<b>Standard</b> = -20°C ÷ +70°C <b>/PE option</b> = -20°C ÷ +70°C
Surface protection	Zinc coating with black passivation (body), tin plating (driver housing)
Corrosion resistance	Salt spray test (EN ISO 9227) > 200 h
Conformity	CE according to EMC directive 2014/30/EU (Immunity: EN 61000-6-2; Emission: EN 61000-6-3) RoHS Directive 2011/65/EU as last update by 2015/863/EU REACH Regulation (EC) n°1907/2006

### 5 HYDRAULIC CHARACTERISTICS - based on mineral oil ISO VG 46 at 50 °C

Valve model	SDHZE						SDKZE									
	ports <b>P, A, B</b> = 350; <b>T</b> = 210						ports <b>P, A, B</b> = 315; <b>T</b> = 210									
Pressure limits [bar]																
Spool type (1)	L3, S3		D3		L5, S5		D5		L3, S3		D3		L5, S5		D5	
Nominal flow Δp P-T [l/min]			P-A A-T	P-B B-T			P-A A-T	P-B B-T			P-A A-T	P-B B-T			P-A A-T	P-B B-T
(2) Δp= 10 bar	18	18	9	28	28	14	45	45	22	75	75	37	130	130	65	
Δp= 30 bar	30	30	15	50	50	25	80	80	40	130	130	65	170	170	85	
Δp= 70 bar	45	45	22	75	75	37	120	120	60	170	170	85	180	180	90	
Max permissible flow	50	50	25	80	80	40	130	130	65	180	180	90	180	180	90	
Leakage [cm <sup>3</sup> /min]	<30 (at p = 100 bar); <135 (at p = 350 bar)						<80 (at p = 100 bar); <600 (at p = 315 bar)									
Response time (3) [ms]	≤ 15						≤ 20									
Hysteresis	≤ 0,2 [% of max regulation]															
Repeatability	± 0,1 [% of max regulation]															
Thermal drift	zero point displacement < 1% at ΔT = 40°C															

(1) For spool type **D\*** the flow value is referred to Δp/2 per control edge

(2) For different Δp, the max flow is in accordance to the diagrams in section 8.2

(3) 0-100% step signal

### 6 ELECTRICAL CHARACTERISTICS

Power supply	Nominal : +24 VDC Rectified and filtered : VRMS = 20 ÷ 32 VMAX (ripple max 10 % VPP)
Max power consumption	50 W
Max. solenoid current	<b>SDHZE</b> = 2,6 A <b>SDKZE</b> = 3 A
Coil resistance R at 20°C	<b>SDHZE</b> = 3,1 Ω <b>SDKZE</b> = 3,2 Ω
Analog input signals	Voltage: range ±10 VDC (24 VMAX tollerant)     Input impedance: Ri > 50 kΩ
Monitor outputs	Output range: voltage ±10 Vdc @ max 5 mA
Alarms	Solenoid not connected/short circuit, cable break with current reference signal, over/under temperature, valve spool transducer malfunctions, alarms history storage function
Insulation class	H (180°) Due to the occurring surface temperatures of the solenoid coils, the European standards ISO 13732-1 and EN982 must be taken into account
Protection degree to DIN EN60529	IP66 / IP67 with mating connectors
Duty factor	Continuous rating (ED=100%)
Additional characteristics	Short circuit protection of solenoid's current supply; spool position control by P.I.D. with rapid solenoid switching; protection against reverse polarity of power supply
Communication interface	USB - Atos ASCII coding
Communication physical layer	not insulated - USB 2.0 + USB OTG
Recommended wiring cable	LiYCY shielded cables, see section 12

**Note:** a maximum time of 400 ms have to be considered between the driver energizing with the 24 Vdc power supply and when the valve is ready to operate. During this time the current to the valve coils is switched to zero.

**7 SEALS AND HYDRAULIC FLUID** - for other fluids not included in below table, consult Atos Technical Office

Seals, recommended fluid temperature	NBR seals (standard) = -20°C ÷ +60°C, with HFC hydraulic fluids = -20°C ÷ +50°C FKM seals (/PE option) = -20°C ÷ +80°C		
Recommended viscosity	20 ÷ 100 mm <sup>2</sup> /s - max allowed range 15 ÷ 380 mm <sup>2</sup> /s		
Max fluid contamination level	normal operation	ISO4406 class 18/16/13 NAS1638 class 7	see also filter section at <a href="http://www.atos.com">www.atos.com</a> or KTF catalog
	longer life	ISO4406 class 16/14/11 NAS1638 class 5	
<b>Hydraulic fluid</b>	<b>Suitable seals type</b>	<b>Classification</b>	<b>Ref. Standard</b>
Mineral oils	NBR, FKM	HL, HLP, HLPD, HVLP, HVLPD	DIN 51524
Flame resistant without water	FKM	HFDU, HFDR	ISO 12922
Flame resistant with water	NBR	HFC	

**8 DIAGRAMS** (based on mineral oil ISO VG 46 at 50 °C)

**8.1 Regulation diagrams** - values measure at Δp 30 bar P-T

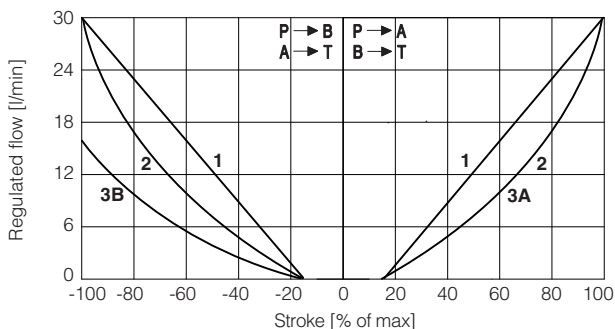

**SDHZE**  
**1 = L3**    **2 = S3**    **3A = D3 (P → A, A → T)**  
**3B = D3 (P → B, B → T)**

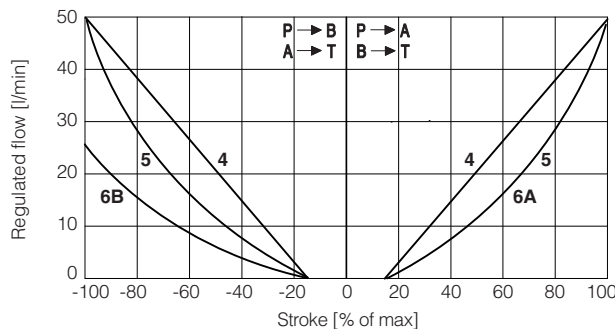

**SDHZE**  
**4 = L5**    **5 = S5**    **6A = D5 (P → A, A → T)**  
**6B = D5 (P → B, B → T)**

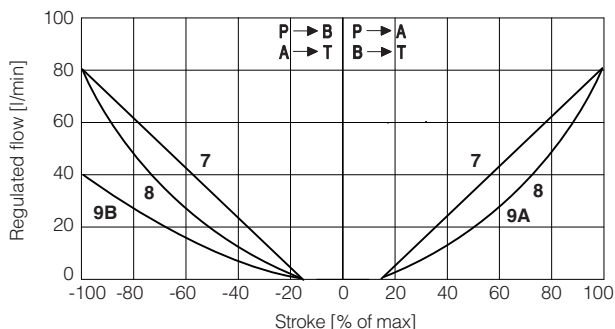

**SDKZE**  
**7 = L3**    **8 = S3**    **9A = D3 (P → A, A → T)**  
**9B = D3 (P → B, B → T)**

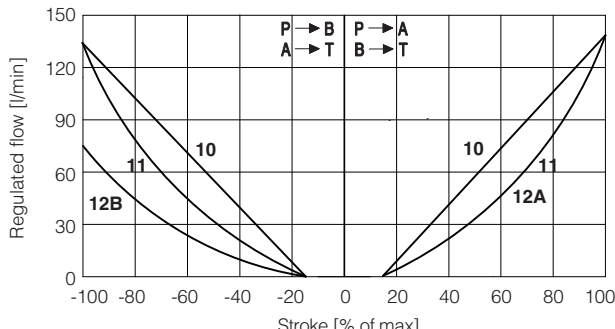

**SDKZE**  
**10 = L5**    **11 = S5**    **12A = D5 (P → A, A → T)**  
**12B = D5 (P → B, B → T)**

**Note:** Hydraulic configuration vs. reference signal for configuration 71 and 73 (standard and option /B)

Reference signal 0 ÷ +10 V } P → A / B → T

Reference signal 0 ÷ -10 V } P → B / A → T

**8.2 Operating limits**

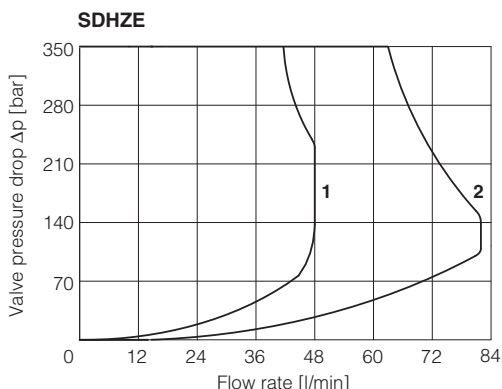

**1 = spool L3, S3, D3**    **2 = spool L5, S5, D5**

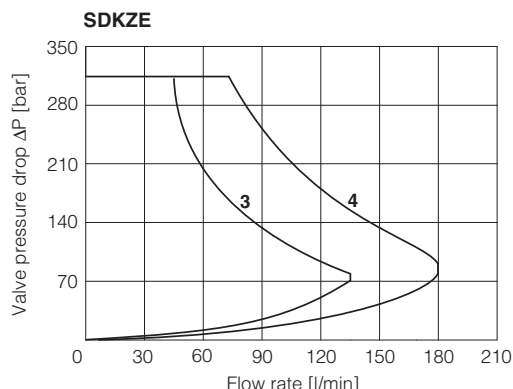

**3 = spool S3, L3, D3**    **4 = spool S5, L5, D5**

**9 OPTIONS**

**B** = Configurations 51, 53: solenoid, on-board digital driver connections and LVDT transducer at side of port A.  
 Configurations 71, 73: on-board digital driver connections and LVDT transducer at side of port A.  
 For hydraulic configuration vs reference signal, see 8.1

**10 POWER SUPPLY AND SIGNALS SPECIFICATIONS**

Generic electrical output signals of the valve (e.g. monitor signal) must not be directly used to activate safety functions, like to switch-ON/OFF the machine's safety components, as prescribed by the European standards (Safety requirements of fluid technology systems and components-hydraulics, EN-982).

**10.1 Power supply (V+ and V0)**

The power supply must be appropriately stabilized or rectified and filtered: apply at least a 10000 µF/40 V capacitance to single phase rectifiers or a 4700 µF/40 V capacitance to three phase rectifiers.

 A safety fuse is required in series to the power supply: 2,5 A time lag fuse.

**10.2 Flow reference input signal (Q\_INPUT+)**

The driver controls in closed loop the valve spool position proportionally to the external reference input signal.  
 Default range is ±10 Vdc

**10.3 Flow monitor output signal (Q\_MONITOR)**

The driver generates an analog output signal proportional to the actual spool position of the valve; the monitor output signal can be software set to show other signals available in the driver.  
 Default range is ±10 Vdc for standard

**Note:** Flow refernece input signal and flow monitor output signal can be software selected with max range ±10 Vdc

**11 ELECTRONIC CONNECTIONS**

**11.1 Main connector signals - 7 pin (A1)**

PIN	SIGNAL	TECHNICAL SPECIFICATIONS	NOTES
A	V+	Power supply 24 Vdc	Input - power supply
B	V0	Power supply 0 Vdc	Gnd - power supply
C	AGND	Analog ground	Gnd - analog signal
D	Q_INPUT+	Flow reference input signal: ±10 Vdc maximum range Default is: ±10 Vdc	Input - analog signal
E	INPUT-	Negative reference input signal for Q_INPUT+	Input - analog signal
F	Q_MONITOR	Flow monitor output signal: ±10 Vdc maximum range, referred to AGND Default is: ±10 Vdc	Output - analog signal
G	EARTH	Internally connected to driver housing	

**11.2 Communication connectors (B)**

**(B) USB connector - M12 - 5 pin** always present

PIN	SIGNAL	TECHNICAL SPECIFICATION (1)
1	+5V_USB	Power supply
2	ID	Identification
3	GND_USB	Signal zero data line
4	D-	Data line -
5	D+	Data line +

**11.3 Connections layout**

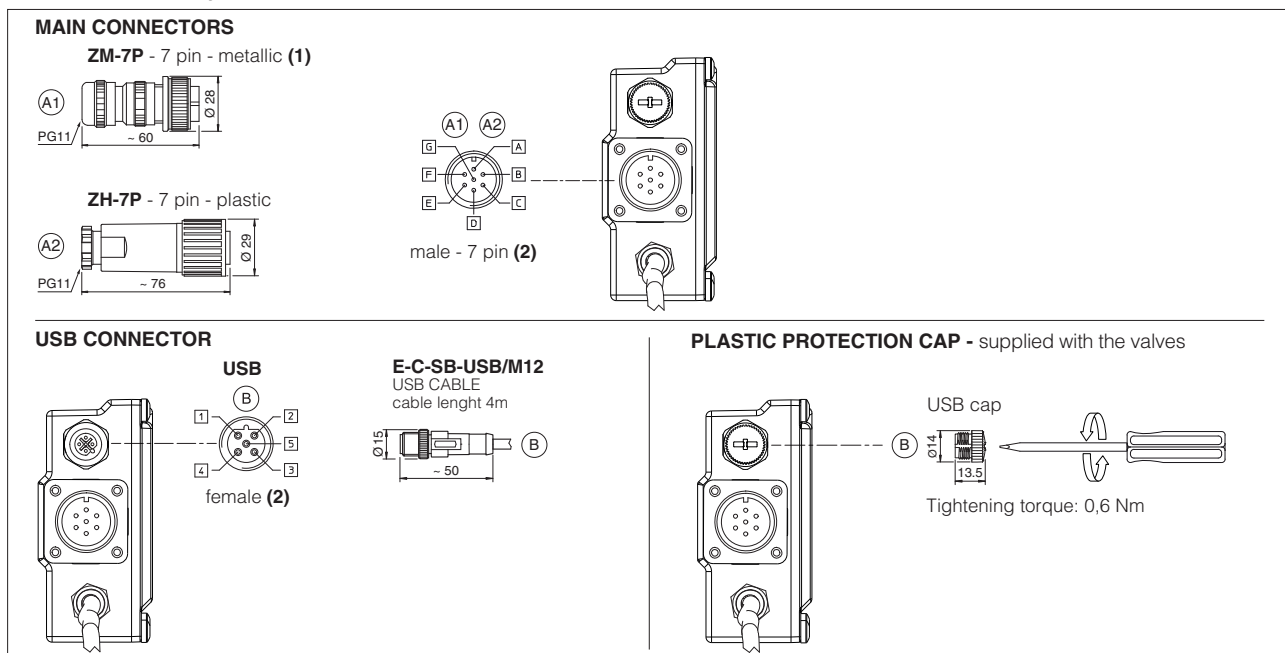



**(1)** use of metallic connectors is strongly recommended in order to fulfill EMC requirements **(2)** pin layout always referred to driver's view

**12 CONNECTORS CHARACTERISTICS** - to be ordered separately

CONNECTOR TYPE	POWER SUPPLY	POWER SUPPLY
CODE	(A1) <b>ZM-7P</b>	(A2) <b>ZH-7P</b>
Type	7pin female straight circular	7pin female straight circular
Standard	According to MIL-C-5015	According to MIL-C-5015
Material	Metallic	Plastic reinforced with fiber glass
Cable gland	PG11	PG11
Recommended cable	LiYCY 7 x 0,75 mm <sup>2</sup> max 20 m (logic and power supply) or LiYCY 7 x 1 mm <sup>2</sup> max 40 m (logic and power supply)	LiYCY 7 x 0,75 mm <sup>2</sup> max 20 m (logic and power supply) or LiYCY 7 x 1 mm <sup>2</sup> max 40 m (logic and power supply)
Conductor size	up to 1 mm <sup>2</sup> - available for 7 wires	up to 1 mm <sup>2</sup> - available for 7 wires
Connection type	to solder	to solder
Protection (EN 60529)	IP 67	IP 67

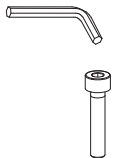
**13 FASTENING BOLTS AND SEALS**

	SDHZE	SDKZE
	<b>Fastening bolts:</b> 4 socket head screws M5x30 class 12.9 Tightening torque = 8 Nm	<b>Fastening bolts:</b> 4 socket head screws M6x40 class 12.9 Tightening torque = 15 Nm
	<b>Seals:</b> 4 OR 108 Diameter of ports A, B, P, T: Ø 7,5 mm (max)	<b>Seals:</b> 5 OR 2050 Diameter of ports A, B, P, T: Ø 11,2 mm (max)

**14 INSTALLATION DIMENSIONS [mm]**

**SDHZE-TID-NP-\***

ISO 4401: 2000 (see table P005)  
 Mounting surface: 4401-03-02-0-05

P, A, B, T = Ø 7,5 max  
 Y = Ø 3,3 max

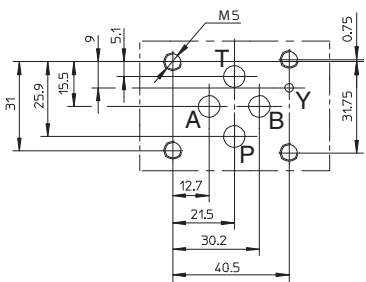

Valve	Mass [kg]
DHZE-05*	2,5
DHZE-07*	3

**SDHZE-TID-NP-05\***

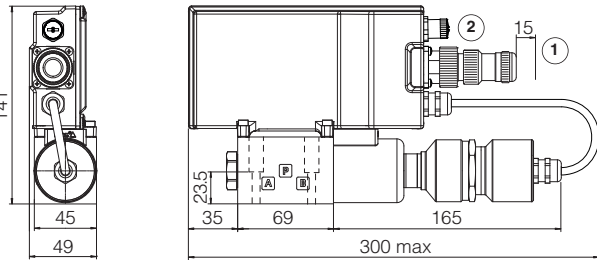

**SDHZE-TID-NP-05\*/B**

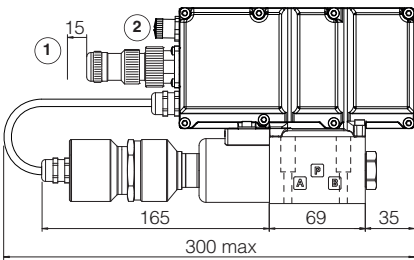

**SDHZE-TID-NP-07\***

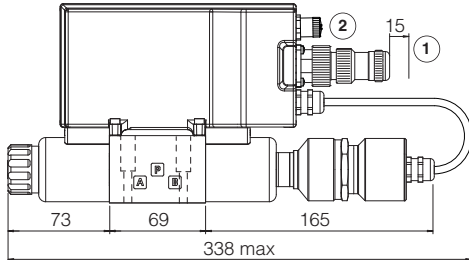

**SDHZE-TID-NP-07\*/B**

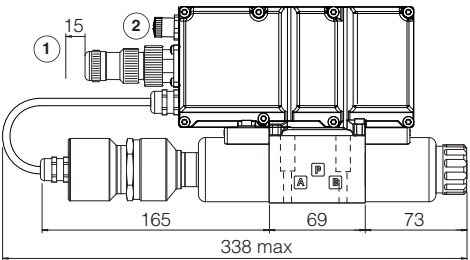

## SDKZE-TID-NP-\*

ISO 4401: 2000 (see table P005)  
 Mounting surface: 4401-05-04-0-05

P, A, B, T =  $\varnothing$  11,2 max

X, Y =  $\varnothing$  6,3 max

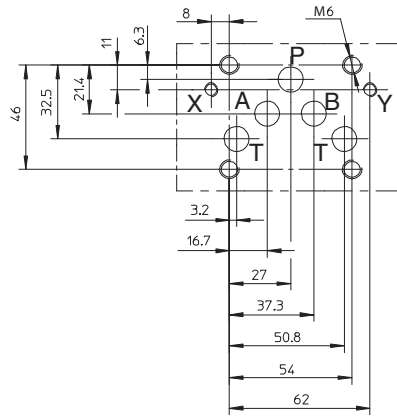

Valve	Mass [kg]
DKZE-15*	5,5
DKZE-17*	7,1

### SDKZE-TID-NP-15\*

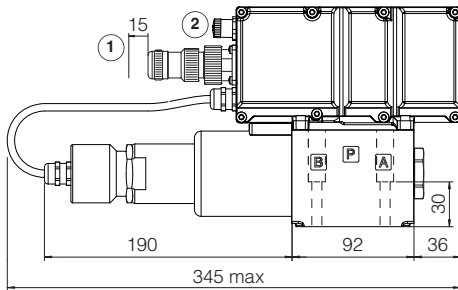

### SDKZE-TID-NP-15\*/B

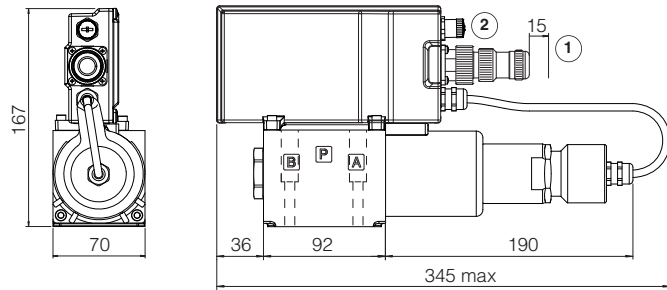

### SDKZE-TID-NP-17\*

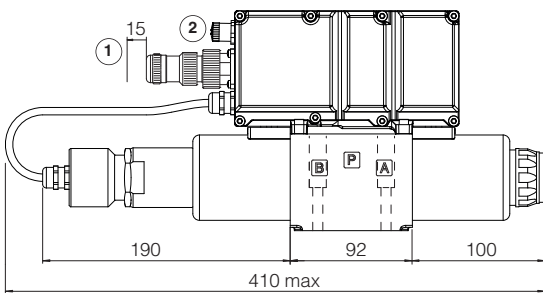

### SDKZE-TID-NP-17\*/B

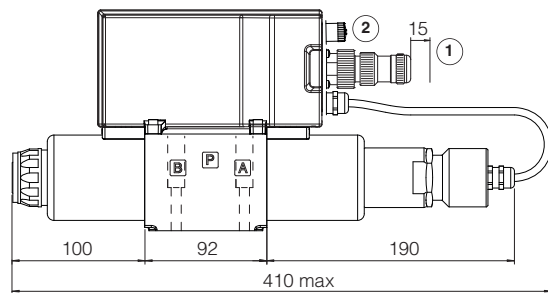

① = Space to remove the connectors

② = The dimensions of all connectors must be considered, see section 11.3