

Proportional relief valves

direct, without transducer

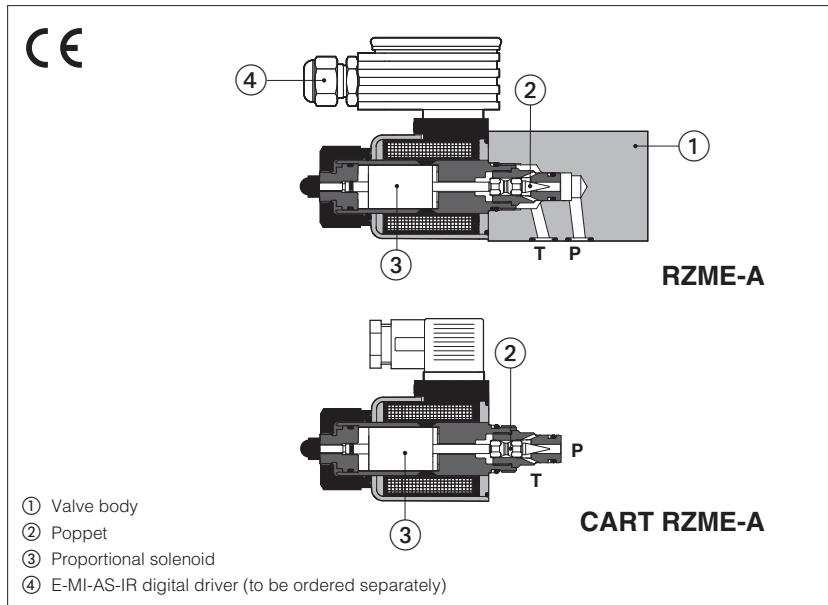

RZME-A, CART RZME-A

Poppet type, direct, proportional pressure relief valves for open loop pressure controls. They operate in association with off-board driver, which supply the proportional valves with proper current to align the valve regulation to the reference signal supplied to the driver.

They are available in following executions:

RZME: subplate mounting, ISO size 06

CART RZME: M20 cartridge execution

The solenoids are certified according to North American standard **cURus**.

Size: **06** - ISO 4401 (RZME); **M20** (CART RZME)

Max flow: **4 l/min**

Max pressure: **420 bar**

For cavity CART RZME see section [15](#)

1 MODEL CODE

RZME	-	A	-	010	/	315	-	*	/	*	/	*	/	*	
Proportional pressure relief valve, direct RZME = subplate mounting CART RZME = cartridge execution												Seals material , see section 8 : - = NBR PE = FKM BT = HNBR			
A = for off-board driver, see section 3												Series number			
Configuration: 010 = regulation on port P, discharge in T												Coil voltage , see section 10 : - = standard coil for 24 Vdc Atos drivers 6 = optional coil for 12 Vdc Atos drivers 18 = optional coil for low current drivers (1)			
Max regulated pressure: 50 = 50 bar 100 = 100 bar 210 = 210 bar 315 = 315 bar 420 = 420 bar												Coil with special connectors , see section 11 : - = omit for standard DIN connector J = AMP Junior Timer connector K = Deutsch connector S = Lead Wire connection			

(1) Select valve's coil voltage /18 in case of electronic drivers not supplied by Atos, with power supply 24 VDC and with max current limited to 1A

2 HYDRAULIC SYMBOL

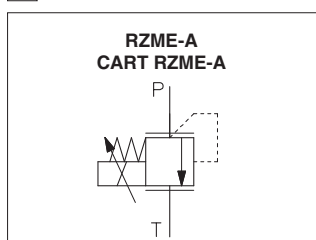

3 OFF-BOARD ELECTRONIC DRIVERS

Drivers model	E-MI-AC-01F (1)		E-MI-AS-IR (1)		E-BM-AS-PS		E-BM-AES
Type	Analog		Digital				
Voltage supply (VDC)	12	24	12	24	12	24	24
Valve coil option	/6	std	/6	std	/6	std	std
Format	plug-in to solenoid				DIN-rail panel		
Tech table	G010		G020		G030		GS050

(1) For **CART RZME** the electronic driver may interfere with the manifold surface. Please check the installation dimensions at section [15](#)

4 GENERAL NOTES

Atos digital proportionals valves are CE marked according to the applicable directives (e.g. Immunity and Emission EMC Directive). Installation, wirings and start-up procedures must be performed according to the general prescriptions shown in tech table **FS900** and in the installation notes supply with relevant components.

5 GENERAL CHARACTERISTICS

Assembly position	Any position
Subplate surface finishing to ISO 4401	Acceptable roughness index: Ra ≤ 0,8, recommended Ra 0,4 – Flatness ratio 0,01/100
MTTFd valves according to EN ISO 13849	150 years, see technical table P007
Ambient temperature range	Standard = -20°C ÷ +70°C /PE option = -20°C ÷ +70°C /BT option = -40°C ÷ +60°C
Storage temperature range	Standard = -20°C ÷ +80°C /PE option = -20°C ÷ +80°C /BT option = -40°C ÷ +70°C
Surface protection	Zinc coating with black passivation
Corrosion resistance	Salt spray test (EN ISO 9227) > 200 h
Conformity	CE according to EMC directive 2014/30/EU (Immunity: EN 61000-6-2; Emission: EN 61000-6-3) RoHS Directive 2011/65/EU as last update by 2015/863/EU REACH Regulation (EC) n°1907/2006

6 HYDRAULIC CHARACTERISTICS

Valve model	RZME-A-010	
Max regulated pressure	50; 100; 210; 315; 420;	
Min. regulated pressure [bar]	see min. pressure / flow diagrams at section 9	
Max. pressure at port P [bar]	420	
Max. pressure at port T [bar]	210	
Max. flow [l/min]	4	
Response time 0-100% step signal (1) [ms] (depending on installation)	≤ 70	
Hysteresis [% of the max pressure]	≤ 3	
Linearity [% of the max pressure]	± 3	
Repeatability [% of the max pressure]	≤ 2	

Note: above performance data refer to valves coupled with Atos electronic drivers, see section 3

(1) Average response time values; the pressure variation in consequence of a modification of the reference input signal to the valve is affected by the stiffness of the hydraulic circuit: greater is the stiffness of the circuit, faster is the dynamic response

7 ELECTRICAL CHARACTERISTICS

	Standard	option /6	option /18
Coil voltage code	standard coil to be used with Atos drivers with power supply 24Vdc	optional coil to be used with Atos drivers with power supply 12 Vdc	optional coil to be used with electronic drivers not supplied by Atos, with power supply 24 Vdc and max current limited to 1A
Max. solenoid current	2,3 A	2,7 A	1,1 A
Coil resistance R at 20°C	3,1 Ω	2,1 Ω	13,1 Ω
Insulation class	H (180°) Due to the occurring surface temperatures of the solenoid coils, the European standards ISO 13732-1 and EN982 must be taken into account		
Protection degree to DIN EN60529	IP 65 (with connectors 666 correctly assembled)		
Duty factor	Continuous rating (ED=100%)		
Certification	cURus North American Standards		

8 SEALS AND HYDRAULIC FLUIDS - for other fluids not included in below table, consult our technical office

Seals, recommended fluid temperature	NBR seals (standard) = -20°C ÷ +80°C, with HFC hydraulic fluids = -20°C ÷ +50°C FKM seals (/PE option) = -20°C ÷ +80°C HNBR seals (/BT option) = -40°C ÷ +60°C, with HFC hydraulic fluids = -40°C ÷ +50°C		
Recommended viscosity	20 ÷ 100 mm ² /s - max allowed range 15 ÷ 380 mm ² /s		
Max fluid contamination level	normal operation	ISO4406 class 18/16/13 NAS1638 class 7	see also filter section at www.atos.com or KTF catalog
	longer life	ISO4406 class 16/14/11 NAS1638 class 5	
Hydraulic fluid	Suitable seals type	Classification	Ref. Standard
Mineral oils	NBR, FKM, HNBR	HL, HLP, HLPD, HVLP, HVLPD	DIN 51524
Flame resistant without water	FKM	HFDR, HFDR	ISO 12922
Flame resistant with water	NBR, HNBR	HFC	

9 DIAGRAMS (based on mineral oil ISO VG 46 at 50 °C)

Regulation diagrams - with flow rate $Q = 1$ l/min

1 = regulation characteristic linearized with Atos digital divers E-MI-AS-IR, E-BM-AS, E-BM-AES using Atos E-SW-BASIC software

2 = regulation characteristic without linearization

Note: the presence of counter pressure at port T can affect the effective pressure regulation

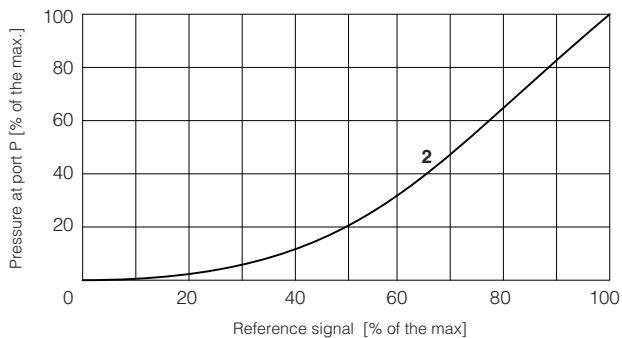
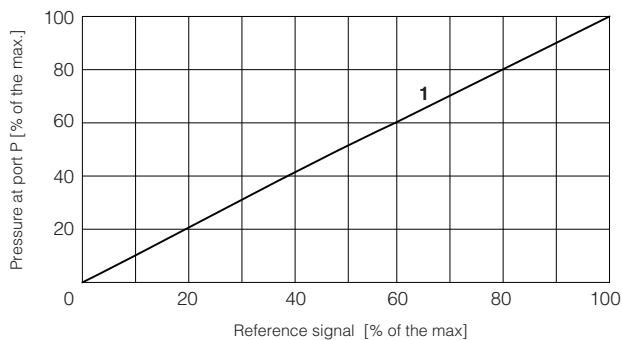

3 = Pressure/flow diagrams

with reference signal set at $Q = 1$ l/min

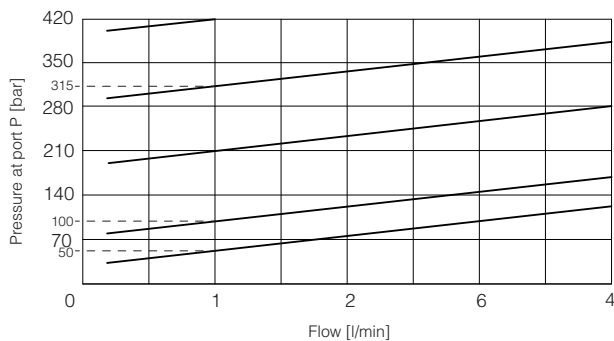

4-7 = Min. pressure/flow diagrams

with zero reference signal

4 = pressure range: 50

5 = pressure range: 100

6 = pressure range: 210

7 = pressure range: 315

8 = pressure range: 420

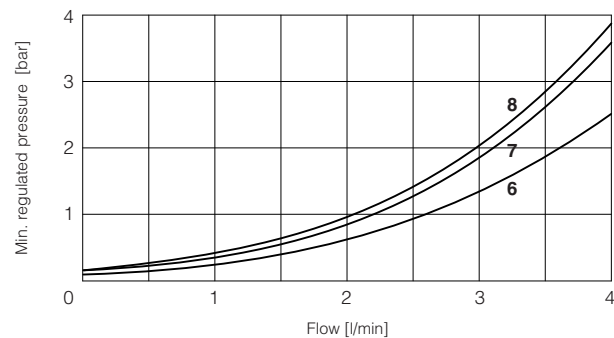
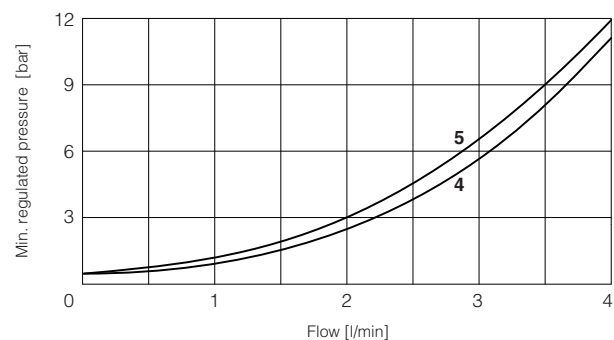

10 COIL VOLTAGE OPTIONS

6 = Optional coil to be used with Atos drivers with power supply 12 Vdc.

18 = Optional coil to be used with electronic drivers not supplied by Atos, with power supply 24 Vdc and with max current limited to 1A.

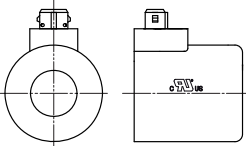
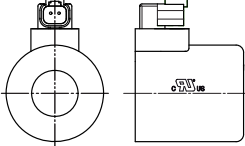
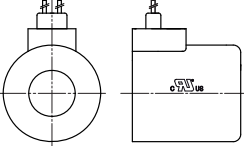

11 COILS WITH SPECIAL CONNECTORS

<p>J option Coil type COZEJ AMP Junior Timer connector Protection degree IP67</p> 	<p>K option Coil type COZEK Deutsch connector, DT-04-2P male Protection degree IP67</p> 	<p>S option Coil type COZES Lead Wire connection Cable length = 180 mm</p> 
--	--	---

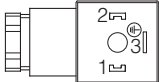
12 SOLENOID CONNECTION

PIN	SIGNAL	TECHNICAL SPECIFICATION	Connector code 666
1	COIL	Power supply	
2	COIL	Power supply	
3	GND	Ground	

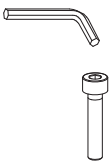
13 FASTENING BOLTS AND SEALS FOR RZME

	<p>Fastening bolts: 4 socket head screws M5x50 class 12.9 Tightening torque = 8 Nm</p>
	<p>Seals: 2 OR 108 Diameter of ports P, T: Ø 5 mm</p>

14 INSTALLATION DIMENSIONS FOR RZME [mm]

ISO 4401: 2005

Mounting surface: 4401-03-02-0-05 (see table P005)
 (without ports A and B)

Mass [kg]	
RZME	1,5
RZME with E-MI-AS-IR	2,0

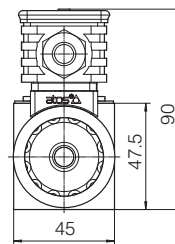
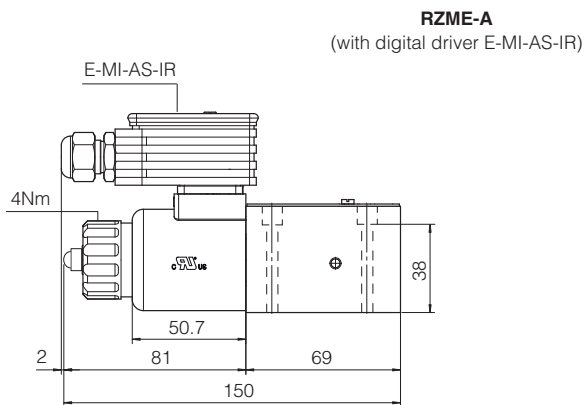
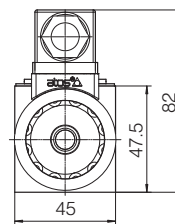
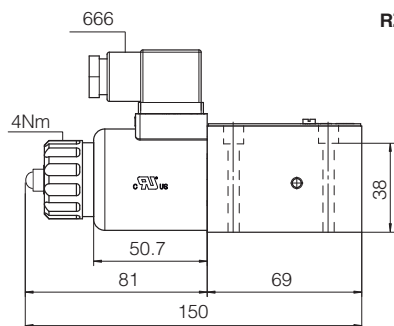
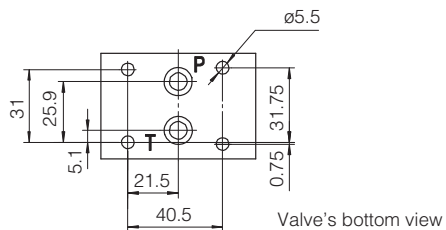

15 INSTALLATION DIMENSIONS FOR CART RZME [mm]

Cavity dimensions for **CART RZME-A**

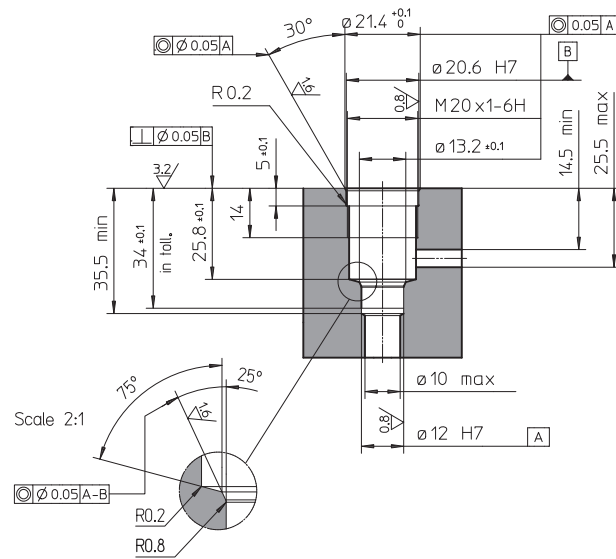

CART RZME-A

CART RZME-A
(with E-MI-AS-IR digital driver)

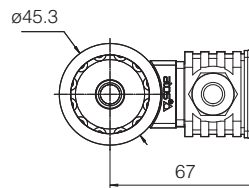
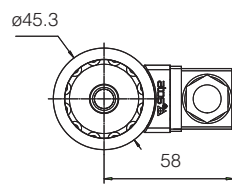
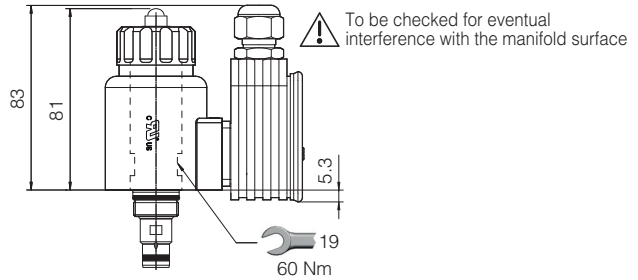
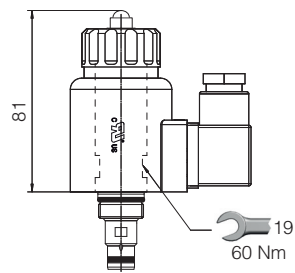

Mass [kg]	
CART RZME	0,6
CART RZME with E-MI-AS-IR	1,1

16 RELATED DOCUMENTATION

FS001	Basics for digital electrohydraulics	GS050	E-BM-AES digital driver
FS900	Operating and maintenance information for proportional valves	GS500	Programming tools
G010	E-MI-AC analog driver	K800	Electric and electronic connectors
G020	E-MI-AS-IR digital driver	P005	Mounting surfaces for electrohydraulic valves
G030	E-BM-AS digital driver		