

# Digital servoproportional 2-way cartridges high flow

piloted, with on-board driver and two LVDT transducers

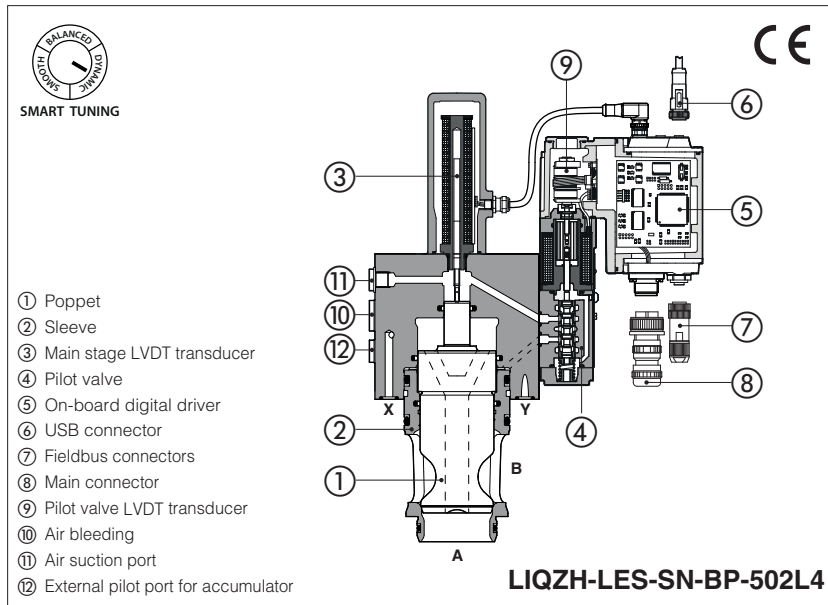

## LIQZH-LEB, LIQZH-LES

High flow 2-way servoproportional cartridge valves specifically designed for high flow applications requiring maximum dynamics and accurate control. Typical applications are die casting and fast forging presses. They are equipped with two LVDT position transducers for best dynamics in not compensated flow regulations.

The cartridge execution for blocks installation grants high flow capabilities and minimized pressure drops.

**LEB** basic execution with analog reference signal or IO-Link interface for digital reference signals, valve settings, and real-time diagnostics.

**LES** full execution which includes also optional fieldbus interfaces for digital reference signals, valve settings, and real-time diagnostics.

For both **LEB** and **LES**, USB port is always present for valve settings via Atos PC software.

Size: 50 ÷ 100 - ISO 7368

Max flow: 5500 ÷ 25000 l/min

Max pressure: 420 bar

### 1 MODEL CODE

<b>LIQZH</b>	-	<b>LES</b>	-	<b>SN</b>	-	<b>NP</b>	-	<b>50</b>	<b>2</b>	<b>L4</b> /	<b>*</b>	/	<b>*</b>				
Servoproportional 2-way cartridge, piloted, high response  <b>LEB</b> = basic on-board digital driver <b>LES</b> = full on-board digital driver  <b>Alternated P/Q controls:</b> <b>SN</b> = none  <b>IO-Link interface</b> , only for LEB, see section [5]: <b>NP</b> = Not present <b>IL</b> = IO-Link  <b>Fieldbus interfaces</b> , only for LES, see section [6]: <b>NP</b> = Not present <b>EW</b> = POWERLINK <b>BC</b> = CANopen <b>EI</b> = EtherNet/IP <b>BP</b> = PROFIBUS DP <b>EP</b> = PROFINET RT/IRT <b>EH</b> = EtherCAT										<b>Seals material</b> , see section [10]: - = NBR <b>PE</b> = FKM <b>BT</b> = NBR low temperature  Series number				<b>Electronics options (1)</b> , not available for LEB-SN-IL: <b>F</b> = fault signal <b>I</b> = current reference input and monitor 4 ÷ 20 mA <b>Q</b> = enable signal <b>Z</b> = double power supply (only for LES), enable, fault and monitor signals - 12 pin connector			
<b>Valve size</b> ISO 7368, see section [8]:										<b>Poppet type</b> , regulating characteristics: L4 = linear							
size	<b>50</b>	<b>63</b>	<b>80</b>	<b>100</b>													
l/min	3200	5200	7200	11000													
Nominal flow (l/min) at Δp 5 bar																	
<b>Configuration:</b> <b>2</b> = 2 way										functional symbol 				simplified symbol 			

(1) Possible combined options: /FI, /IQ, /IZ

## 2 GENERAL NOTES

Atos digital proportionals valves are CE marked according to the applicable directives (e.g. Immunity and Emission EMC Directive). Installation, wirings and start-up procedures must be performed according to the general prescriptions shown in tech table **FS900** and in the user manuals included in the E-SW-\* programming software.

### WARNING

To avoid overheating and possible damage of the electronic driver, the valves must be never energized without hydraulic supply to the pilot stage. In case of prolonged pauses of the valve operation during the machine cycle, it is always advisable to disable the driver (option /Q or /Z). A safety fuse 2,5 A installed on 24Vdc power supply of each valve is always recommended, see also power supply note at sections **15**.

### WARNING

The loss of the pilot pressure causes the undefined position of the main poppet.  
The sudden interruption of the power supply during the valve operation causes the immediate shut-off of the main poppet.  
This could cause pressure surges in the hydraulic system or high decelerations which may lead to machine damages.

## 3 VALVE SETTINGS AND PROGRAMMING TOOLS

Valve's functional parameters and configurations, can be easily set and optimized using Atos E-SW programming software connected via USB/Bluetooth to the digital driver.  
For fieldbus/IO-Link versions, the software permits valve's parameterization through USB/Bluetooth also if the driver is connected to the central machine unit via fieldbus/IO-Link.

The software is available in different versions according to the driver's options (see table **GS500**):

**E-SW-BASIC** support: NP (USB) IL (IO-Link) PS (Serial) IR (Infrared)

**E-SW-FIELDBUS** support: BC (CANopen) BP (PROFIBUS DP) EH (EtherCAT)  
EW (POWERLINK) EI (EtherNet/IP) EP (PROFINET)

**E-SW-\*/PQ** support: valves with SP, SF, SL alternated control (e.g. E-SW-BASIC/PQ)

 **WARNING: drivers USB port is not isolated!** For E-C-SB-USB/M12 cable, the use of isolator adapter is highly recommended for PC protection

 **WARNING:** see tech table **GS500** for the list of countries where the Bluetooth adapter has been approved

### USB or Bluetooth connection

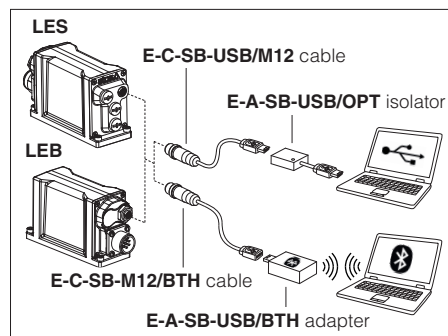

## 4 SMART TUNING

Smart tuning allows to adjust the cartridge dynamic response in order to match different performance requirements.

The cartridge is provided with 3 factory settings for the spool control:

- **dynamic** fast response time and high sensitivity for best dynamic performances. Default factory setting for cartridges
- **balanced** average response time and sensitivity suitable for major applications
- **smooth** attenuated response time and sensitivity to improve control stability in critical applications or in environments with electrical disturbances

Smart tuning setting can be switched from Dynamic (default) to Balanced or Smooth via software or fieldbus; if requested, performances can be further customized directly tuning each single control parameter. For details consult related manuals E-MAN-RI-\*, see section **23**.

For Response time and Bode diagrams see section **11**.

## 5 IO-LINK - only for LEB, see tech. table **GS520**

IO-Link allows low cost digital communication between the valve and machine central unit. The valve is directly connected to a port of an IO-Link master (point-to-point connection) via low-cost unshielded cables for digital reference, diagnostic and settings. The IO-Link master works as a hub exchanging this information with the machine central unit via fieldbus.

## 6 FIELDBUS - only for LES, see tech. table **GS510**

Fieldbus allows valve direct communication with machine control unit for digital reference, valve diagnostics and settings. These execution allow to operate the valves through fieldbus or analog signals available on the main connector.

## 7 GENERAL CHARACTERISTICS

Assembly position	Any position
Subplate surface finishing to ISO 4401	Acceptable roughness index: Ra ≤0,8, recommended Ra 0,4 – Flatness ratio 0,01/100
MTTFd valves according to EN ISO 13849	75 years, for further details see technical table P007
Ambient temperature range	<b>Standard</b> = -20°C ÷ +60°C <b>/PE</b> option = -20°C ÷ +60°C <b>/BT</b> option = -40°C ÷ +60°C
Storage temperature range	<b>Standard</b> = -20°C ÷ +70°C <b>/PE</b> option = -20°C ÷ +70°C <b>/BT</b> option = -40°C ÷ +70°C
Surface protection	Zinc coating with black passivation, galvanic treatment (driver housing)
Corrosion resistance	Salt spray test (EN ISO 9227) > 200 h
Vibration resistance	See technical table G004
Compliance	CE according to EMC directive 2014/30/EU (Immunity: EN 61000-6-2; Emission: EN 61000-6-3) RoHS Directive 2011/65/EU as last update by 2015/863/EU REACH Regulation (EC) n°1907/2006

## 8 HYDRAULIC CHARACTERISTICS - based on mineral oil ISO VG 46 at 50 °C

Size	50	63	80	100
Max regulated flow [l/min]				
at Δp = 5 bar	3200	5200	7200	11000
at Δp = 10 bar	4500	7350	10200	15550
Max permissible flow	5500	10500	17000	25000
Max pressure [bar]	Ports A, B = 420    X = 350    Y < 210			
Nominal flow of pilot valve at Δp = 70 bar [l/min]	40	100	100	100
Leakage of pilot valve at P = 100 bar [l/min]	0,7	1	1	1
Piloting pressure [bar]	recommended: system pressure (max 350);    minimum 140			
Response time 0 ÷ 100% step signal <b>(2)</b> [ms]	24	24	29	33
Hysteresis [% of the max regulation]	≤ 0,1			
Repeatability [% of the max regulation]	± 0,1			
Thermal drift	zero point displacement < 1% at ΔT = 40°C			

**(1)** With step reference input 0÷100%

**(2)** With pilot pressure = 140 bar, see detailed diagrams in section 11.2

## 9 ELECTRICAL CHARACTERISTICS

Power supplies	Nominal : +24 VDC Rectified and filtered : V <sub>RMS</sub> = 20 ÷ 32 V <sub>MAX</sub> (ripple max 10 % V <sub>PP</sub> )				
Max power consumption	50 W				
Max. solenoid current	2,6 A				
Coil resistance R at 20°C	3 ÷ 3,3 Ω				
Analog input signals	Voltage: range ±10 Vdc (24 V <sub>MAX</sub> tolerant) Current: range ±20 mA		Input impedance: Ri > 50 kΩ Input impedance: Ri = 500 Ω		
Monitor outputs	Output range:    voltage    ±10 Vdc @ max 5 mA current    ±20 mA @ max 500 Ω load resistance				
Enable input	Range: 0 ÷ 5 Vdc (OFF state), 9 ÷ 24 Vdc (ON state), 5 ÷ 9 Vdc (not accepted); Input impedance: Ri > 10 kΩ				
Fault output	Output range: 0 ÷ 24 Vdc (ON state > [power supply - 2 V] ; OFF state < 1 V ) @ max 50 mA; external negative voltage not allowed (e.g. due to inductive loads)				
Alarms	Solenoid not connected/short circuit, cable break with current reference signal, over/under temperature, valve spool transducer malfunctions, alarms history storage function				
Insulation class	H (180°) Due to the occurring surface temperatures of the solenoid coils, the European standards ISO 13732-1 and EN982 must be taken into account				
Protection degree to DIN EN60529	IP66 / IP67 with mating connectors				
Duty factor	Continuous rating (ED=100%)				
Tropicalization	Tropical coating on electronics PCB				
Additional characteristics	Short circuit protection of solenoid's current supply; 3 leds for diagnostic (only for LES); poppet position control by P.I.D. with rapid solenoid switching; protection against reverse polarity of power supply				
Communication interface	USB Atos ASCII coding	IO-Link Interface and System Specification 1.1.3	CANopen EN50325-4 + DS408	PROFIBUS DP EN50170-2/IEC61158	EtherCAT POWERLINK EtherNet/IP PROFINET IO RT/IRT IEC 61158
Communication physical layer	not insulated USB 2.0+ USB OTG	SDCI class port B	optical insulated CAN ISO11898	optical insulated RS485	Fast Ethernet, insulated 100 Base TX
Recommended wiring cable	LIYCY shielded cables, see section 19				

**Note:** a maximum time of 800 ms (depending on communication type) has to be considered between the driver energizing with the 24 Vdc power supply and when the valve is ready to operate. During this time the current to the valve coils is switched to zero.

**10 SEALS AND HYDRAULIC FLUIDS** - for other fluids not included in below table, consult our technical office

Seals, recommended fluid temperature	NBR seals (standard) = -20°C ÷ +60°C, with HFC hydraulic fluids = -20°C ÷ +50°C FKM seals (/PE option) = -20°C ÷ +80°C NBR low temp. seals (/BT option) = -40°C ÷ +60°C, with HFC hydraulic fluids = -20°C ÷ +50°C		
Recommended viscosity	20 ÷ 100 mm <sup>2</sup> /s - max allowed range 15 ÷ 380 mm <sup>2</sup> /s		
Max fluid contamination level	normal operation	ISO4406 class 18/16/13	NAS1638 class 7
	longer life	ISO4406 class 16/14/11	NAS1638 class 5
			see also filter section at <a href="http://www.atos.com">www.atos.com</a> or KTF catalog
<b>Hydraulic fluid</b>	<b>Suitable seals type</b>	<b>Classification</b>	<b>Ref. Standard</b>
Mineral oils	NBR, FKM, NBR low temp.	HL, HLP, HLPD, HVLP, HVLPD	DIN 51524
Flame resistant without water	FKM	HFDU, HFDR	ISO 12922
Flame resistant with water	NBR, NBR low temp.	HFC	

**11 DIAGRAMS** (based on mineral oil ISO VG 46 at 50 °C)

**11.1 Regulation diagrams** (values measured at Δp 5 bar)

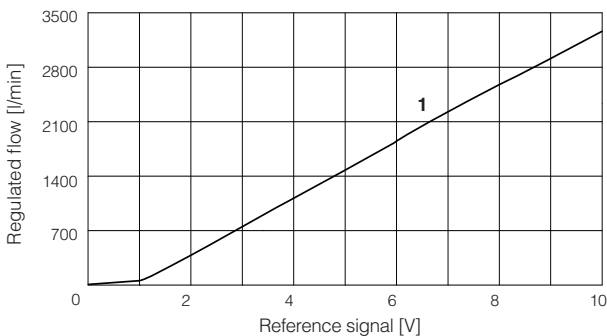

**1** = LIQZH-L\*-502L4

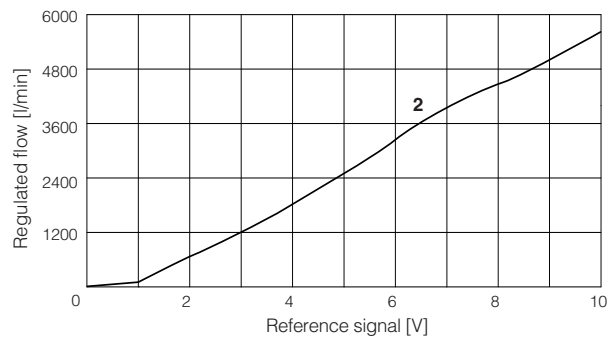

**2** = LIQZH-L\*-632L4

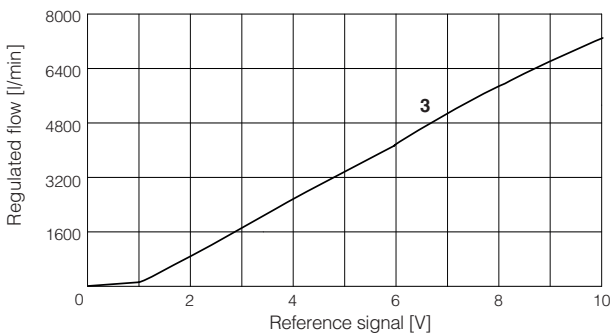

**3** = LIQZH-L\*-802L4

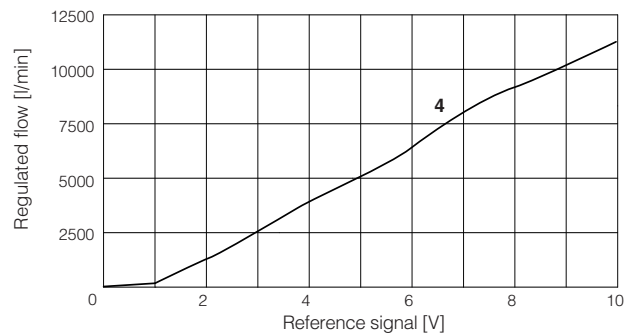

**4** = LIQZH-L\*-1002L4

### 11.2 Response time

The response times in below diagrams are measured at different steps of the reference input signal. They have to be considered as average values. For the valves with digital electronics the dynamics performances can be optimized by setting the internal software parameters.

#### LIQZH-50

#### LIQZH-63

- 1 = dynamic
- 2 = balanced
- 3 = smooth

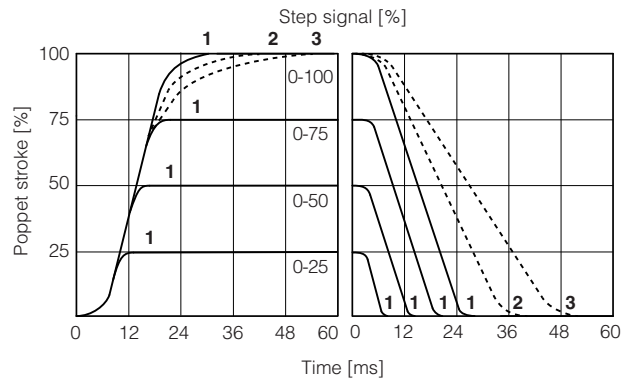

#### LIQZH-80

- 1 = dynamic
- 2 = balanced
- 3 = smooth

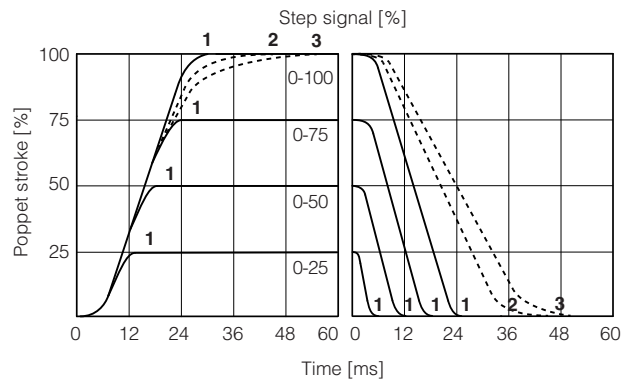

#### LIQZH-100

- 1 = dynamic
- 2 = balanced
- 3 = smooth

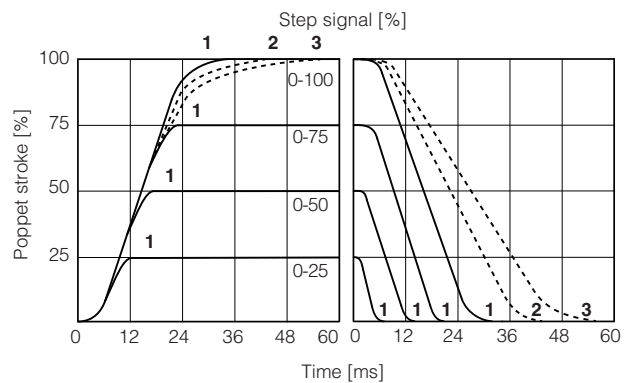

**11.3 Bode diagrams** - stated at nominal hydraulic conditions

**LIQZH-LE\*-502L4**

Stated at nominal hydraulic conditions

50% ± 5% nominal stroke:

- 1 = dynamic
- 2 = balanced
- 3 = smooth

10% ↔ 90% nominal stroke:

- 4 = dynamic
- 5 = balanced
- 6 = smooth

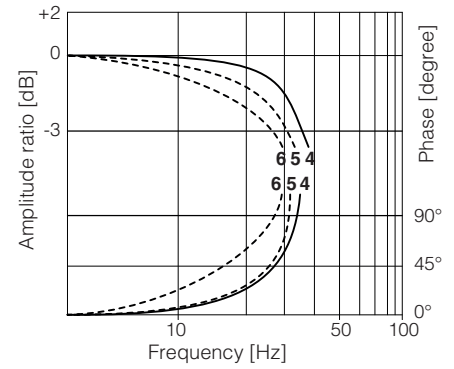
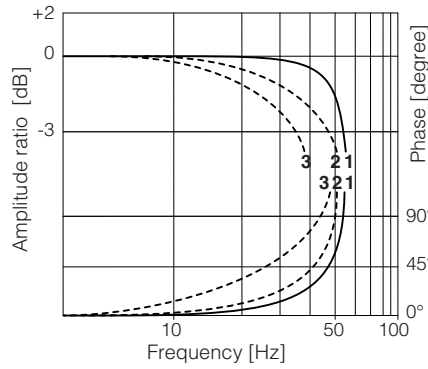

**LIQZH-LE-632L4**

Stated at nominal hydraulic conditions

50% ± 5% nominal stroke:

- 1 = dynamic
- 2 = balanced
- 3 = smooth

10% ↔ 90% nominal stroke:

- 4 = dynamic
- 5 = balanced
- 6 = smooth

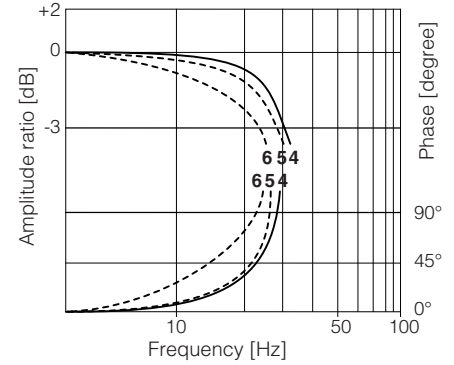
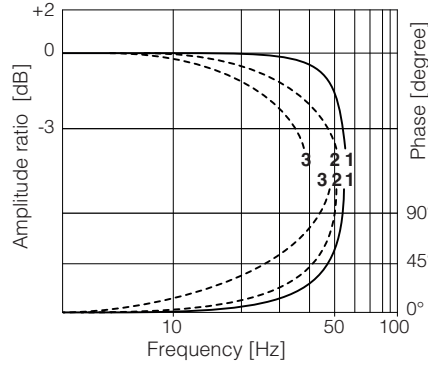

**LIQZH-LE\*-802L4**

Stated at nominal hydraulic conditions

50% ± 5% nominal stroke:

- 1 = dynamic
- 2 = balanced
- 3 = smooth

10% ↔ 90% nominal stroke:

- 4 = dynamic
- 5 = balanced
- 6 = smooth

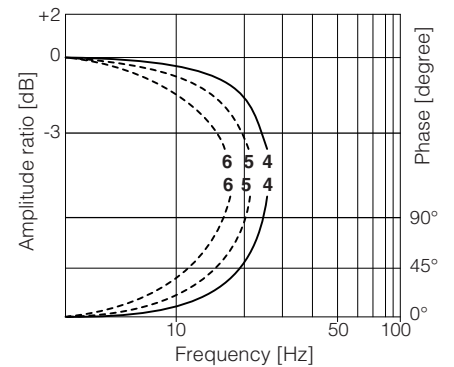
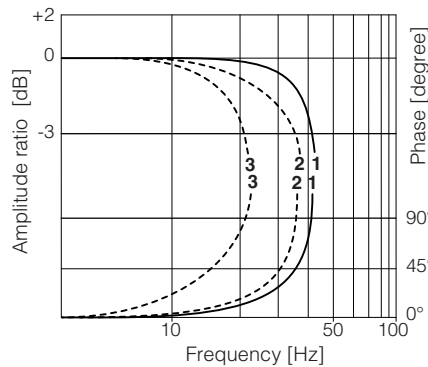

**LIQZH-LE\*-1002L4**

Stated at nominal hydraulic conditions

50% ± 5% nominal stroke:

- 1 = dynamic
- 2 = balanced
- 3 = smooth

10% ↔ 90% nominal stroke:

- 4 = dynamic
- 5 = balanced
- 6 = smooth

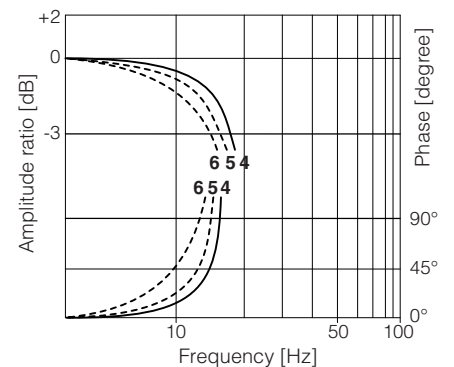
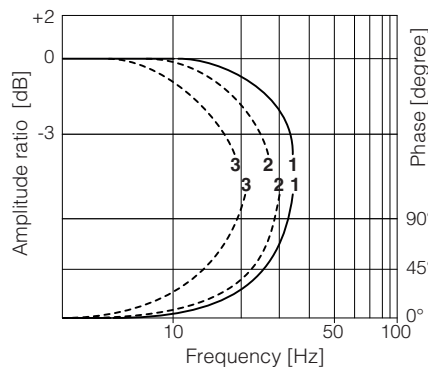

**12 ELECTRONICS OPTIONS** - not available for **LEB-SN-IL**

- F** = This option permits to monitor the eventual fault condition of the driver, as for example the solenoid short circuit/not connected, reference signal cable broken for option /I, poppet position transducer broken, etc. - see 15.7 for signal specifications.
- I** = This option provides 4 ÷ 20 mA current reference and monitor signals, instead of the standard 0 ÷ 10 VDC.  
Input signal can be reconfigured via software selecting between voltage and current, within a maximum range of ±10 VDC or ±20 mA.  
It is normally used in case of long distance between the machine control unit and the valve or where the reference signal can be affected by electrical noise; the valve functioning is disabled in case of reference signal cable breakage.
- Q** = This option permits to inhibit the valve function without removing the power supply to the driver. Upon disable command the current to the solenoid is zeroed and the valve's poppet moves to rest position.  
The option /Q is suggested for all cases where the valve has to be frequently inhibited during the machine cycle – see 15.5 for signal specifications.
- Z** = This option provides, on the 12 pin main connector, the following additional features:  
**Fault output signal** - see above option /F  
**Enable input signal** - see above option /Q  
**Repeat enable output signal** - only for **LEB-SN-NP** (see 15.6)  
**Power supply for driver's logics and communication** - only for **LES** (see 15.2)

**13 POSSIBLE COMBINED OPTIONS**

/FI, /IQ, /IZ

**14 AIR BLEEDING**

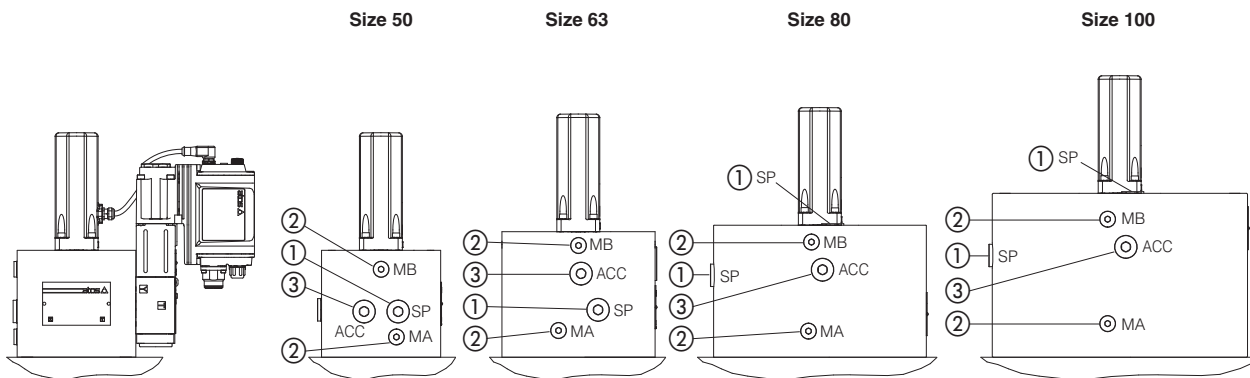

- ① To be used only in case port A is connected to tank and subjected to negative pressure, consult our technical office.
- ② At the machine commissioning it is advisable to bleed the air from piloting chambers, by loosening the 2 plugs shown in the picture.  
Operate the valve for few seconds at low pressure and then lock the plugs.
- ③ Additional external pilot port for accumulator connection.

Port	LIQZH Size			
	50	63	80	100
① Air suction		G1/2" CH 10		
② Air bleeding		G1/4" CH 6		
③ External pilot		G1/2" CH 10		

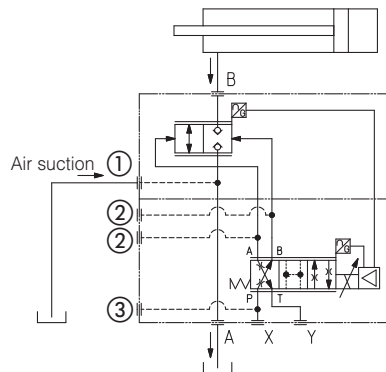

## 15 POWER SUPPLY AND SIGNALS SPECIFICATIONS

Generic electrical output signals of the valve (e.g. fault or monitor signals) must not be directly used to activate safety functions, like to switch-ON/OFF the machine's safety components, as prescribed by the European standards (Safety requirements of fluid technology systems and components-hydraulics, ISO 4413).

For **LEB-SN-IL** signals see section 16

### 15.1 Power supply (V+ and V0)

The power supply must be appropriately stabilized or rectified and filtered: apply at least a 10000  $\mu$ F/40 V capacitance to single phase rectifiers or a 4700  $\mu$ F/40 V capacitance to three phase rectifiers. In case of separate power supply see 15.2.



A safety fuse is required in series to each power supply: 2,5 A time lag fuse.

### 15.2 Power supply for driver's logic and communication (VL+ and VL0) - only for LES with /Z option

The power supply for driver's logic and communication must be appropriately stabilized or rectified and filtered: apply at least a 10000  $\mu$ F/40 V capacitance to single phase rectifiers or a 4700  $\mu$ F/40 V capacitance to three phase rectifiers.

The separate power supply for driver's logic on pin 9 and 10, allow to remove solenoid power supply from pin 1 and 2 maintaining active the diagnostics, USB and fieldbus communications.



A safety fuse is required in series to each driver's logic and communication power supply: 500 mA fast fuse.

### 15.3 Flow reference input signal (Q\_INPUT+)

The driver controls in closed loop the valve spool position proportionally to the external reference input signal.

Reference input signal is factory preset according to selected valve code, defaults are  $\pm 10$  VDC for standard and  $4 \div 20$  mA for /I option.

Input signal can be reconfigured via software selecting between voltage and current, within a maximum range of  $\pm 10$  VDC or  $\pm 20$  mA.

Drivers with fieldbus interface can be software set to receive reference signal directly from the machine control unit (fieldbus reference).

Analog reference input signal can be used as on-off commands with input range  $0 \div 24$ VDC.

### 15.4 Flow monitor output signal (Q\_MONITOR) - not for /F

The driver generates an analog output signal proportional to the actual spool position of the valve; the monitor output signal can be software set to show other signals available in the driver (e.g. analog reference, fieldbus reference, pilot spool position).

Monitor output signal is factory preset according to selected valve code, defaults are  $\pm 10$  VDC for standard and  $4 \div 20$  mA for /I option.

Output signal can be reconfigured via software selecting between voltage and current, within a maximum range of  $\pm 10$  VDC or  $\pm 20$  mA.

### 15.5 Enable input signal (ENABLE) - not for standard and /F

To enable the driver, supply a 24 VDC on pin 3 (pin C): Enable input signal allows to enable/disable the current supply to the solenoid, without removing the electrical power supply to the driver; it is used to active the communication and the other driver functions when the valve must be disabled for safety reasons. This condition **does not comply** with norms IEC 61508 and ISO 13849.

Enable input signal can be used as generic digital input by software selection.

### 15.6 Repeat enable output signal (R\_ENABLE) - only for LEB-SN-NP with /Z option

Repeat enable is used as output repeater signal of enable input signal (see 15.5).

### 15.7 Fault output signal (FAULT) - not for standard and /Q

Fault output signal indicates fault conditions of the driver (solenoid short circuits/not connected, reference signal cable broken for  $4 \div 20$  mA input, spool position transducer cable broken, etc.). Fault presence corresponds to 0 VDC, normal working corresponds to 24 VDC.

Fault status is not affected by the Enable input signal. Fault output signal can be used as digital output by software selection.

## 16 IO-LINK SIGNALS SPECIFICATIONS - only for LEB-SN-IL

### 16.1 Power supply for IO-Link communication (L+ and L-)

The IO-Link master provides dedicated 24 Vdc power supply for IO-Link communication.

Maximum power consumption: 2 W

Internal electrical isolation of power L+, L- from P24, N24

### 16.2 Power supply for drive logic and valve regulation (P24 and N24)

The IO-Link master provides dedicated 24 VDC power supply for valve regulation, logics and diagnostics.

Maximum power consumption: 50 W

Internal electrical isolation of power P24, N24 from L+, L-

### 16.3 IO-Link data line (C/Q)

C/Q signal is used to establish communication between IO-Link master and valve.



## 17 ELECTRONIC CONNECTIONS AND LEDS

### 17.1 Main connector signals - 7 pin - standard, /Q and /F options (A1)

PIN	Standard	/Q	/F	TECHNICAL SPECIFICATIONS	NOTES
A	V+			Power supply 24 Vdc	Input - power supply
B	V0			Power supply 0 Vdc	Gnd - power supply
C	AGND		AGND	Analog ground	Gnd - analog signal
		ENABLE		Enable (24 Vdc) or disable (0 Vdc) the valve, referred to V0	Input - on/off signal
D	Q_INPUT+			Flow reference input signal: $\pm 10$ Vdc / $\pm 20$ mA maximum range Defaults are 0 $\div$ 10 Vdc for standard and 4 $\div$ 20 mA for /I option	Input - analog signal <b>Software selectable</b>
E	INPUT-			Negative reference input signal for Q_INPUT+	Input - analog signal
F	Q_MONITOR referred to:			Flow monitor output signal: $\pm 10$ Vdc / $\pm 20$ mA maximum range Defaults are 0 $\div$ 10 Vdc for standard and 4 $\div$ 20 mA for /I option	Output - analog signal <b>Software selectable</b>
	AGND	V0			
			FAULT	Fault (0 Vdc) or normal working (24 Vdc)	Output - on/off signal
G	EARTH			Internally connected to the driver housing	

### 17.2 Main connector signal - 12 pin - /Z option (A2)

PIN	LEB /Z	LES /Z	TECHNICAL SPECIFICATIONS	NOTES
1	V+		Power supply 24 Vdc	Input - power supply
2	V0		Power supply 0 Vdc	Gnd - power supply
3	ENABLE referred to: V0   VL0		Enable (24 Vdc) or disable (0 Vdc) the valve	Input - on/off signal
4	Q_INPUT+		Flow reference input signal: $\pm 10$ Vdc / $\pm 20$ mA maximum range Defaults are 0 $\div$ 10 Vdc for standard and 4 $\div$ 20 mA for /I option	Input - analog signal <b>Software selectable</b>
5	INPUT-		Negative reference input signal for Q_INPUT+	Input - analog signal
6	Q_MONITOR referred to: AGND   VL0		Flow monitor output signal: $\pm 10$ Vdc / $\pm 20$ mA maximum range Defaults are 0 $\div$ 10 Vdc for standard and 4 $\div$ 20 mA for /I option	Input - analog signal <b>Software selectable</b>
7	AGND		Analog ground	Output - analog signal
		NC	Do not connect	Gnd - analog signal
8	R_ENABLE		Repeat enable, output repeater signal of enable input, referred to V0	Output - on/off signal
		NC	Do not connect	
9	NC		Do not connect	
		VL+	Power supply 24 Vdc for driver's logic and communication	Input - power supply
10	NC		Do not connect	
		VL0	Power supply 0 Vdc for driver's logic and communication	Gnd - power supply
11	FAULT referred to: V0   VL0		Fault (0 Vdc) or normal working (24 Vdc)	Output - on/off signal
PE	EARTH		Internally connected to the driver housing	

**Note:** do not disconnect VL0 before VL+ when the driver is connected to PC USB port

### 17.3 IO-Link connector signals - M12 - 5 pin - Coding A, port class B (A) only for LEB-SN-IL

PIN	SIGNAL	TECHNICAL SPECIFICATIONS	NOTES
1	L+	Power supply 24 Vdc for IO-Link communication	Input - power supply
2	P24	Power supply 24 Vdc for valve regulation, logics and diagnostics	Input - power supply
3	L-	Power supply 0 Vdc for IO-Link communication	Gnd - power supply
4	C/Q	IO-Link data line	Input / Output - signal
5	N24	Power supply 0 Vdc for valve regulation, logics and diagnostics	Gnd - power supply

**Note:** L+, L- and P24, N24 are electrically isolated

### 17.4 Communications connectors (B) - (C)

(B) USB connector - M12 - 5 pin always present		
PIN	SIGNAL	TECHNICAL SPECIFICATION (1)
1	+5V_USB	Power supply
2	ID	Identification
3	GND_USB	Signal zero data line
4	D-	Data line -
5	D+	Data line +

(C1) (C2) BC fieldbus execution, connector - M12 - 5 pin		
PIN	SIGNAL	TECHNICAL SPECIFICATION (1)
1	CAN_SHLD	Shield
2	not used	(C1) - (C2) pass-through connection (2)
3	CAN_GND	Signal zero data line
4	CAN_H	Bus line (high)
5	CAN_L	Bus line (low)

(C1) (C2) BP fieldbus execution, connector - M12 - 5 pin		
PIN	SIGNAL	TECHNICAL SPECIFICATION (1)
1	+5V	Termination supply signal
2	LINE-A	Bus line (high)
3	DGND	Data line and termination signal zero
4	LINE-B	Bus line (low)
5	SHIELD	

(C1) (C2) EH, EW, EI, EP fieldbus execution, connector - M12 - 4 pin		
PIN	SIGNAL	TECHNICAL SPECIFICATION (1)
1	TX+	Transmitter
2	RX+	Receiver
3	TX-	Transmitter
4	RX-	Receiver
	SHIELD	

(1) shield connection on connector's housing is recommended

(2) Pin 2 can be fed with external +5V supply of CAN interface

## 17.5 LEB-SN-NP connections layout

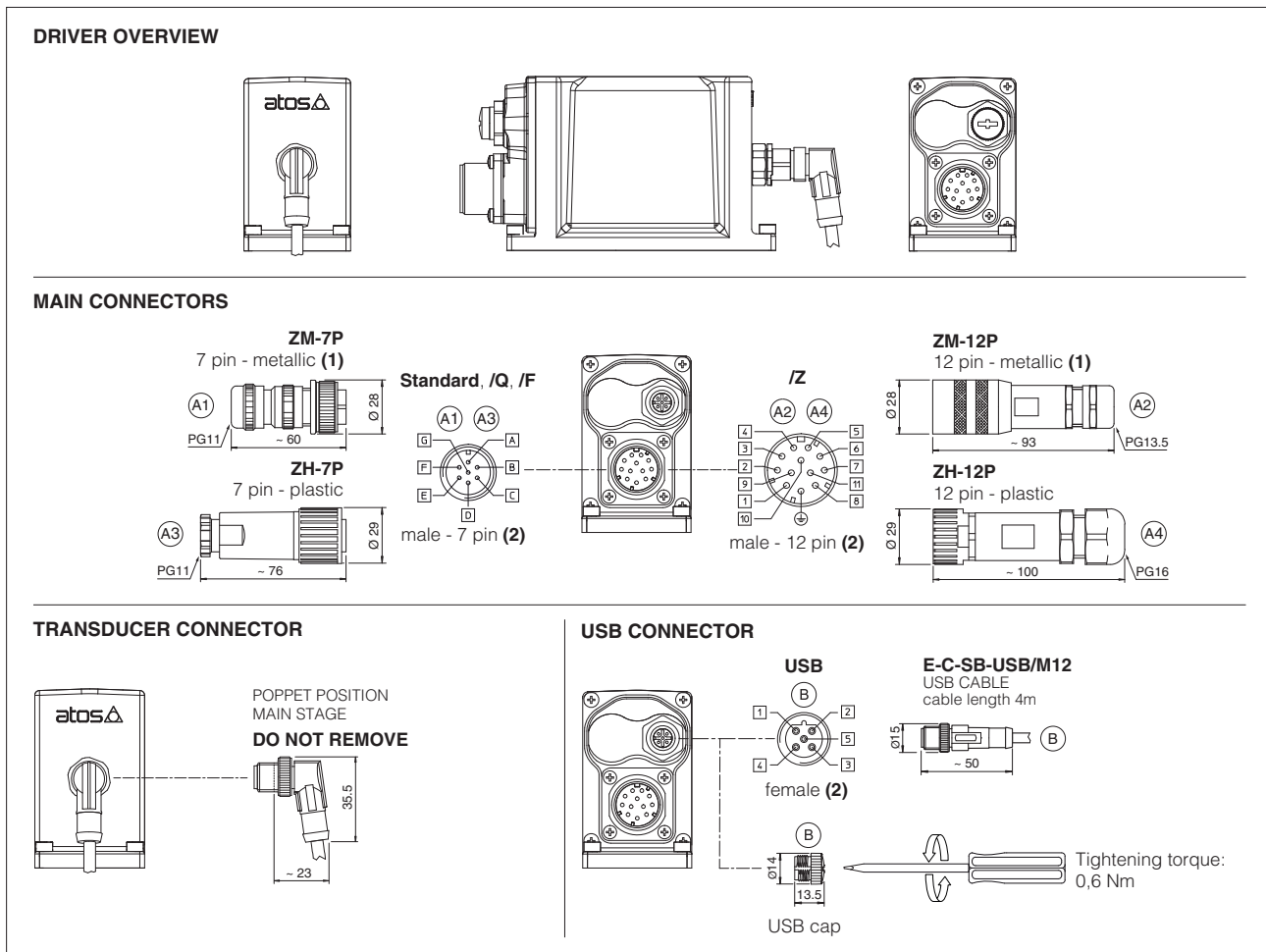

(1) Use of metallic connectors is strongly recommended in order to fulfill EMC requirements (2) Pin layout always referred to driver's view

## 17.6 LEB-SN-IL connections layout

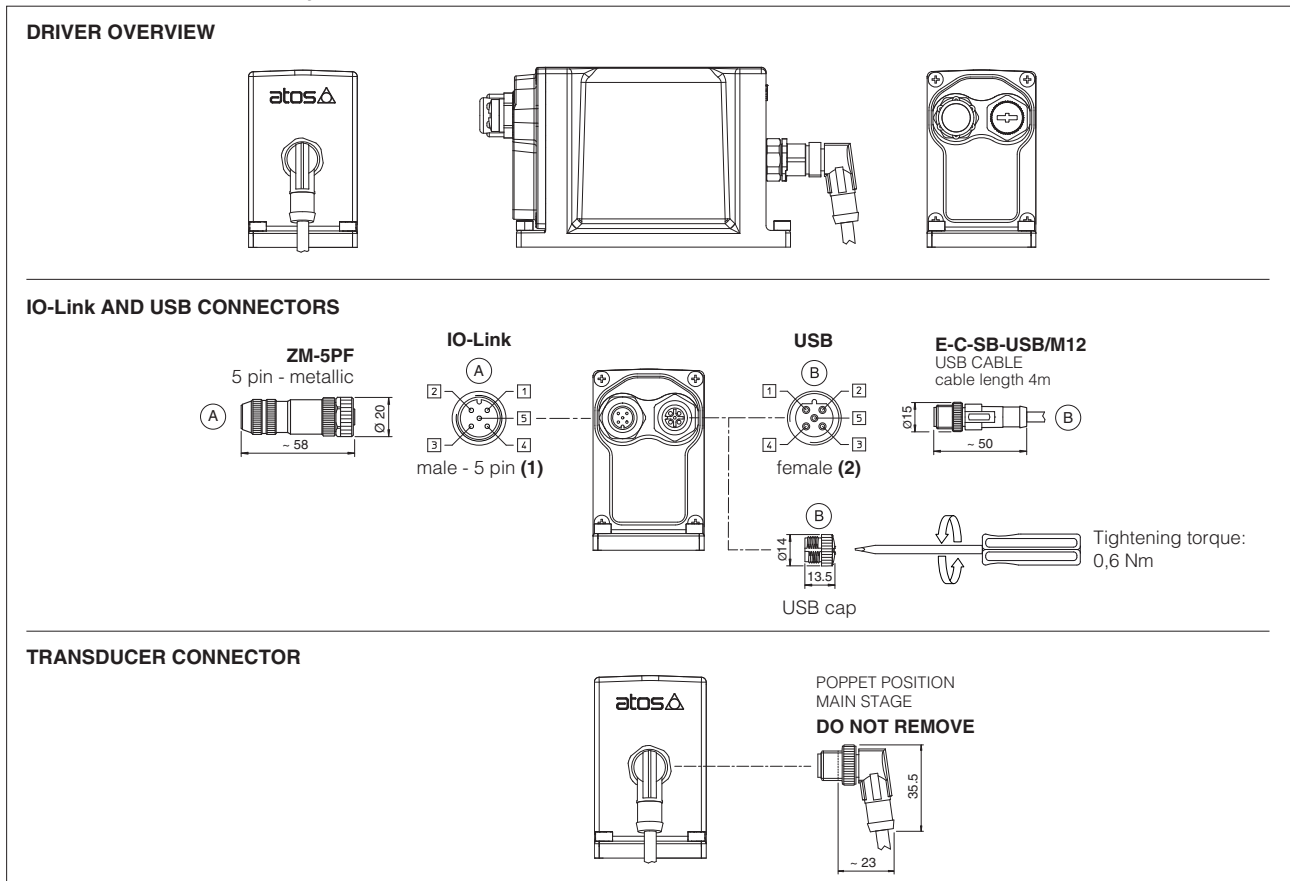

(1) Pin layout always referred to driver's view

## 17.7 LES connections layout

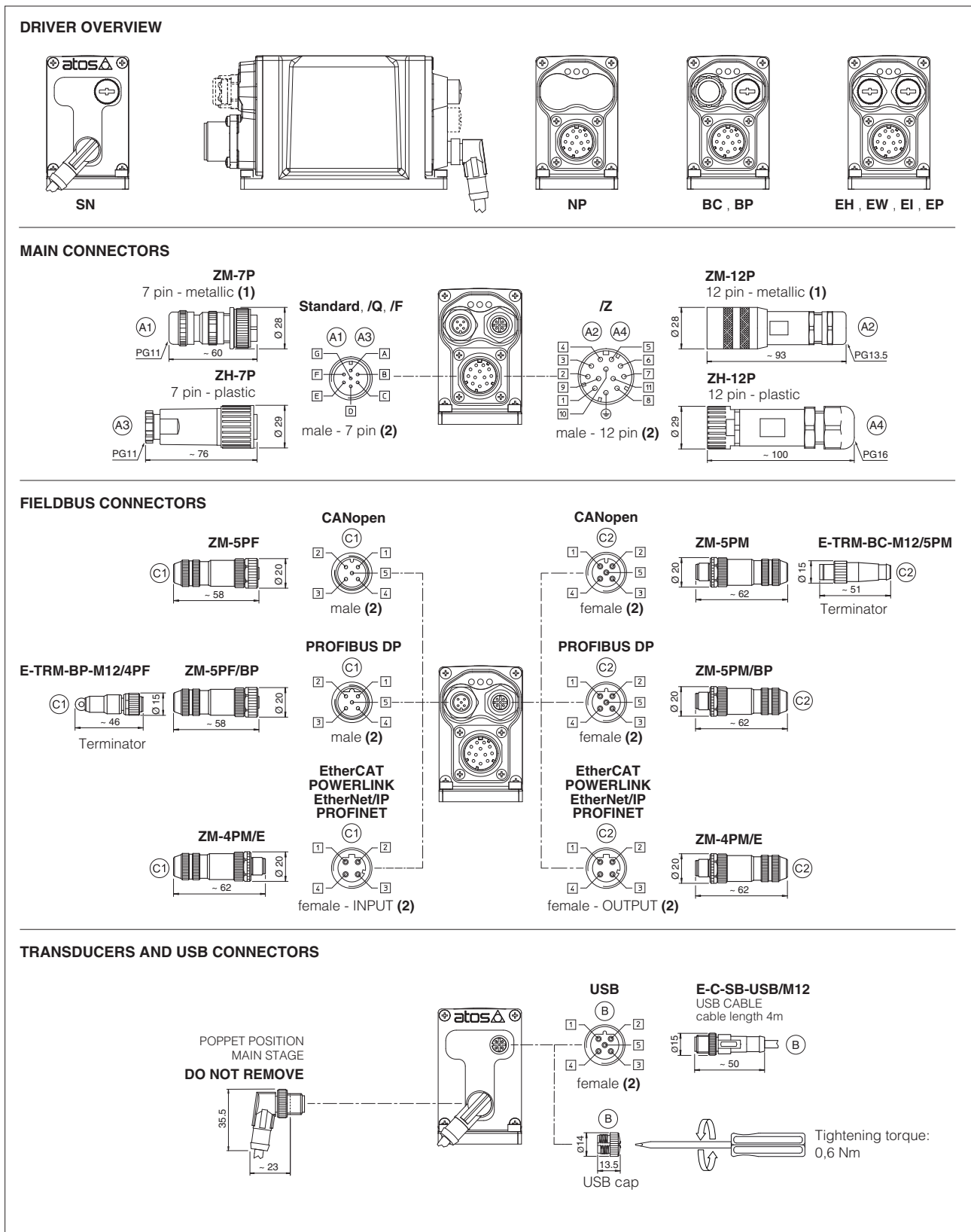

(1) Use of metallic connectors is strongly recommended in order to fulfill EMC requirements (2) Pin layout always referred to driver's view

## 17.8 Diagnostic LEDs - only for LES

Three leds show driver operative conditions for immediate basic diagnostics. Please refer to the driver user manual for detailed information.

FIELDBUS LEDS	NP Not Present	BC CANopen	BP PROFIBUS DP	EH EtherCAT	EW POWERLINK	EI EtherNet/IP	EP PROFINET	L1 L2 L3
L1		VALVE STATUS			LINK/ACT			
L2		NETWORK STATUS			NETWORK STATUS			
L3		SOLENOID STATUS			LINK/ACT			

## 18 IN / OUT FIELDBUS COMMUNICATION CONNECTORS

Two fieldbus communication connectors are always available for digital drivers executions BC, BP, EH, EW, EI, EP. This features allows considerable technical advantages in terms of installation simplicity, wirings reduction and also avoid the usage expensive T-connectors.

For BC and BP executions the fieldbus connectors have an internal pass-through connection and can be used like end point of the fieldbus network, using an external terminator (see tech table **GS500**).

For EH, EW, EI and EP executions the external terminators are not required: each connector is internally terminated.

### BC and BP pass-through connection

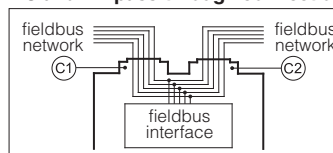

## 19 CONNECTORS CHARACTERISTICS - to be ordered separately

### 19.1 Main connectors - 7 pin

CONNECTOR TYPE	POWER SUPPLY AND SIGNALS	POWER SUPPLY AND SIGNALS
<b>CODE</b>	<b>(A1) ZM-7P</b>	<b>(A3) ZH-7P</b>
Type	7pin female straight circular	7pin female straight circular
Standard	According to MIL-C-5015	According to MIL-C-5015
Material	Metallic	Plastic reinforced with fiber glass
Cable gland	PG11	PG11
Recommended cable	LiYCY 7 x 0,75 mm <sup>2</sup> max 20 m (logic and power supply) or LiYCY 7 x 1 mm <sup>2</sup> max 40 m (logic and power supply)	LiYCY 7 x 0,75 mm <sup>2</sup> max 20 m (logic and power supply) or LiYCY 7 x 1 mm <sup>2</sup> max 40 m (logic and power supply)
Conductor size	up to 1 mm <sup>2</sup> - available for 7 wires	up to 1 mm <sup>2</sup> - available for 7 wires
Connection type	to solder	to solder
Protection (EN 60529)	IP 67	IP 67

### 19.2 Main connectors - 12 pin

CONNECTOR TYPE	POWER SUPPLY AND SIGNALS	POWER SUPPLY AND SIGNALS
<b>CODE</b>	<b>(A2) ZM-12P</b>	<b>(A4) ZH-12P</b>
Type	12pin female straight circular	12pin female straight circular
Standard	DIN 43651	DIN 43651
Material	Metallic	Plastic reinforced with fiber glass
Cable gland	PG13,5	PG16
Recommended cable	LiYCY 12 x 0,75 mm <sup>2</sup> max 20 m (logic and power supply)	LiYCY 10 x 0,14mm <sup>2</sup> max 40 m (logic) LiYY 3 x 1mm <sup>2</sup> max 40 m (power supply)
Conductor size	0,5 mm <sup>2</sup> to 1,5 mm <sup>2</sup> - available for 12 wires	0,14 mm <sup>2</sup> to 0,5 mm <sup>2</sup> - available for 9 wires 0,5 mm <sup>2</sup> to 1,5 mm <sup>2</sup> - available for 3 wires
Connection type	to crimp	to crimp
Protection (EN 60529)	IP 67	IP 67

### 19.3 IO-Link connector - only for LEB-SN-IL

CONNECTOR TYPE	IL IO-Link
<b>CODE</b>	<b>(A) ZM-5PF</b>
Type	5pin female straight circular
Standard	M12 coding A – IEC 61076-2-101
Material	Metallic
Cable gland	Pressure nut - cable diameter 6÷8 mm
Recommended cable	5 x 0,75 mm <sup>2</sup> max 20 m
Connection type	screw terminal
Protection (EN 60529)	IP 67

### 19.4 Fieldbus communication connectors

CONNECTOR TYPE	BC CANopen (1)		BP PROFIBUS DP (1)		EH EtherCAT, EW POWERLINK, EI EtherNet/IP, EP PROFINET (2)
	<b>(C1) ZM-5PF</b>	<b>(C2) ZM-5PM</b>	<b>(C1) ZM-5PF/BP</b>	<b>(C2) ZM-5PM/BP</b>	<b>(C1) (C2) ZM-4PM/E</b>
Type	5 pin female straight circular	5 pin male straight circular	5 pin female straight circular	5 pin male straight circular	4 pin male straight circular
Standard	M12 coding A – IEC 61076-2-101		M12 coding B – IEC 61076-2-101		M12 coding D – IEC 61076-2-101
Material	Metallic		Metallic		Metallic
Cable gland	Pressure nut - cable diameter 6÷8 mm		Pressure nut - cable diameter 6÷8 mm		Pressure nut - cable diameter 4÷8 mm
Cable	CANbus Standard (DR 303-1)		PROFIBUS DP Standard		Ethernet standard CAT-5
Connection type	screw terminal		screw terminal		terminal block
Protection (EN 60529)	IP67		IP 67		IP 67

(1) E-TRM-\*\* terminators can be ordered separately - see tech table **GS500**

(2) Internally terminated

**20 FASTENING BOLTS AND VALVE MASS**

Type	Size	Fastening bolts (1)	Mass [kg]
LIQZH	50	4 socket head screws M20x80 class 12.9 Tightening torque = 600 Nm	23,0
	63	4 socket head screws M30x120 class 12.9 Tightening torque = 2100 Nm	41,5
	80	8 socket head screws M24x80 class 12.9 Tightening torque = 1000 Nm	66,0
	100	8 socket head screws M30x120 class 12.9 Tightening torque = 2100 Nm	113

(1) Fastening bolts supplied with the valve

**21 MAIN CONNECTORS INSTALLATION DIMENSIONS**

**Installation 1** - possible interference between manifold and main connector

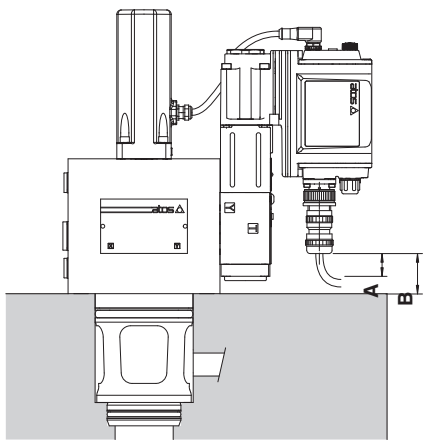

**A** = 15 mm space to remove the 7 or 12 pin main connectors  
**B** = Clearance between main connector to valve's mounting surface.  
 See the below table to verify eventual interferences, depending to the valve size and connector type

**Installation 2** - no interference

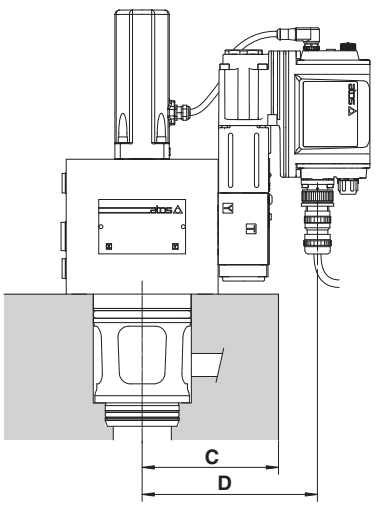

**C** = Max manifold dimension to avoid interference with the main connector, see below table

Reference dimension	Main connector code	Valve size			
		50	63	80	100
<b>B</b>	ZM-7P	38	96	98	125
	ZH-7P	(1)	80	82	109
	ZM-12P	(1)	51	53	65
	ZH-12P	(1)	44	46	58
<b>C (max)</b>	-	141	172	202	230
<b>D</b>	-	161	192	222	250

Above dimensions refer to the main connector fully screwed to driver's connector. The space **A** = 15 mm to remove the connector must be considered

- (1) The connector installation can be performed only if the valve's driver protrudes from the edge of the relevant mounting manifold as represented in above "Installation 2"
- (2) The connector installation may be critic, depending to the cable size and bending radius

LIQZH-LEB-502  
LIQZH-LES-502

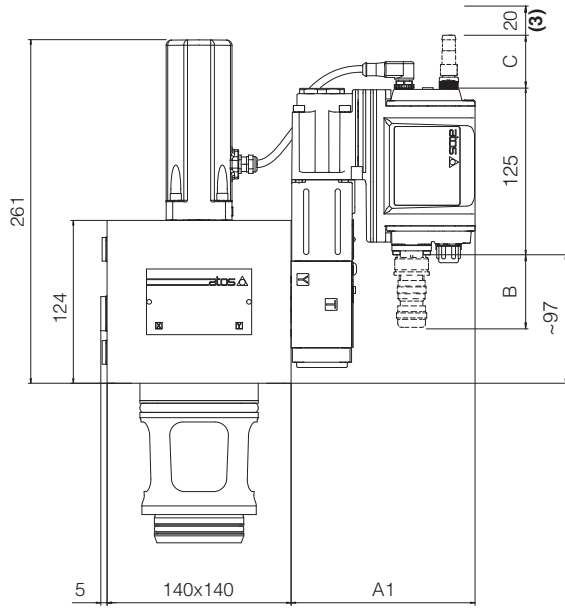

LIQZH-LEB-632  
LIQZH-LES-632

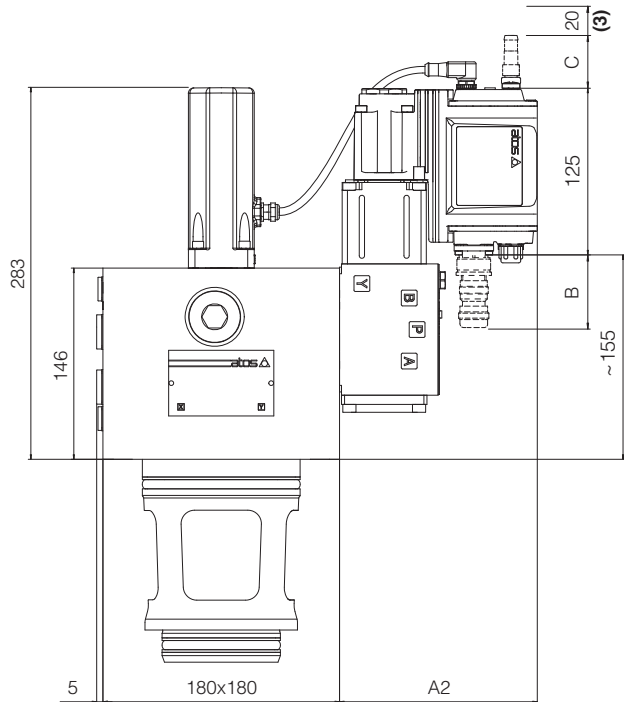

LIQZH	A1	A2	B (1)	C (2)
LEB - SN - IL	140	150	60	-
LEB - SN - NP	140	150	60	-
LES - SN - NP, BC, BP, EH	140	150	60	50
LES - SN - EW, EI, EP	155	165	60	50

- (1) The indicated dimension refers to the main connector ZM-7P. See section 21 for main connectors installation dimensions
- (2) The indicated dimension refers to the longer main connector. For dimensions of all connectors, see sections 17.5, 17.6 and 17.7
- (3) Space required for connector cable and for connector removal

**Note:** for mounting surface and cavity dimensions, see table P006

LIQZH-LEB-802  
LIQZH-LES-802

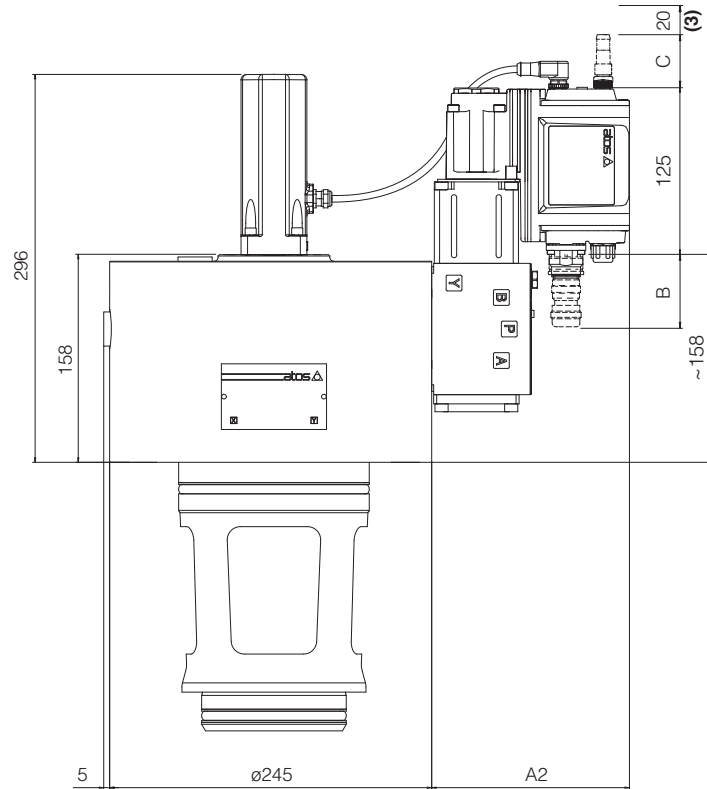

LIQZH	A2	B (1)	C (2)
LEB - SN - IL	150	60	-
LEB - SN - NP	150	60	-
LES - SN - NP, BC, BP, EH	150	60	50
LES - SN - EW, EI, EP	165	60	50

- (1) The indicated dimension refers to the main connector ZM-7P. See section 21 for main connectors installation dimensions  
(2) The indicated dimension refers to the longer main connector. For dimensions of all connectors, see sections 17.5, 17.6 and 17.7  
(3) Space required for connector cable and for connector removal

**Note:** for mounting surface and cavity dimensions, see table P006

LIQZH-LEB-1002  
LIQZH-LES-1002

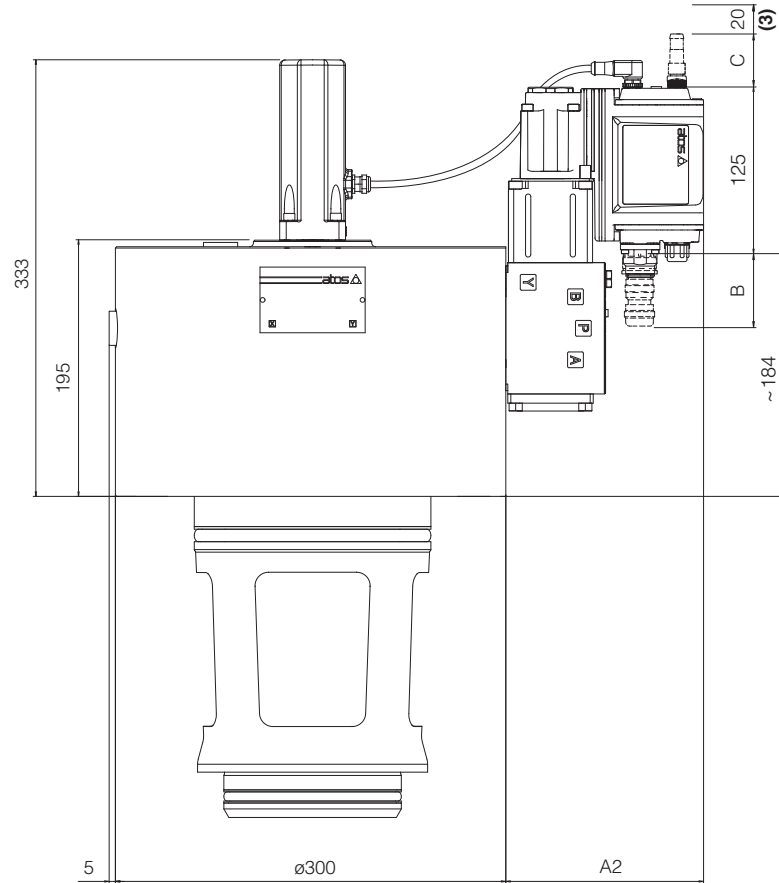

LIQZH	A2	B (1)	C (2)
LEB - SN - IL	150	60	-
LEB - SN - NP	150	60	-
LES - SN - NP, BC, BP, EH	150	60	50
LES - SN - EW, EI, EP	165	60	50

(1) The indicated dimension refers to the main connector ZM-7P. See section 21 for main connectors installation dimensions

(2) The indicated dimension refers to the longer main connector. For dimensions of all connectors, see sections 17.5, 17.6 and 17.7

(3) Space required for connector cable and for connector removal

**Note:** for mounting surface and cavity dimensions, see table P006

23 RELATED DOCUMENTATION

**FS001** Basics for digital electrohydraulics  
**FS900** Operating and maintenance information for proportional valves  
**GS500** Programming tools  
**GS510** Fieldbus  
**GS520** IO-Link interface

**K800** Electric and electronic connectors  
**P006** Mounting surfaces and cavities for cartridge valves  
**E-MAN-RI-LEB** TEB/LEB user manual  
**E-MAN-RI-LES** TES/LES user manual