

STARTUP E-SW-FIELDBUS

INSTALLATION AND CONFIGURATION
E-SW-FIELDBUS & E-SW-FIELDBUS/PQ

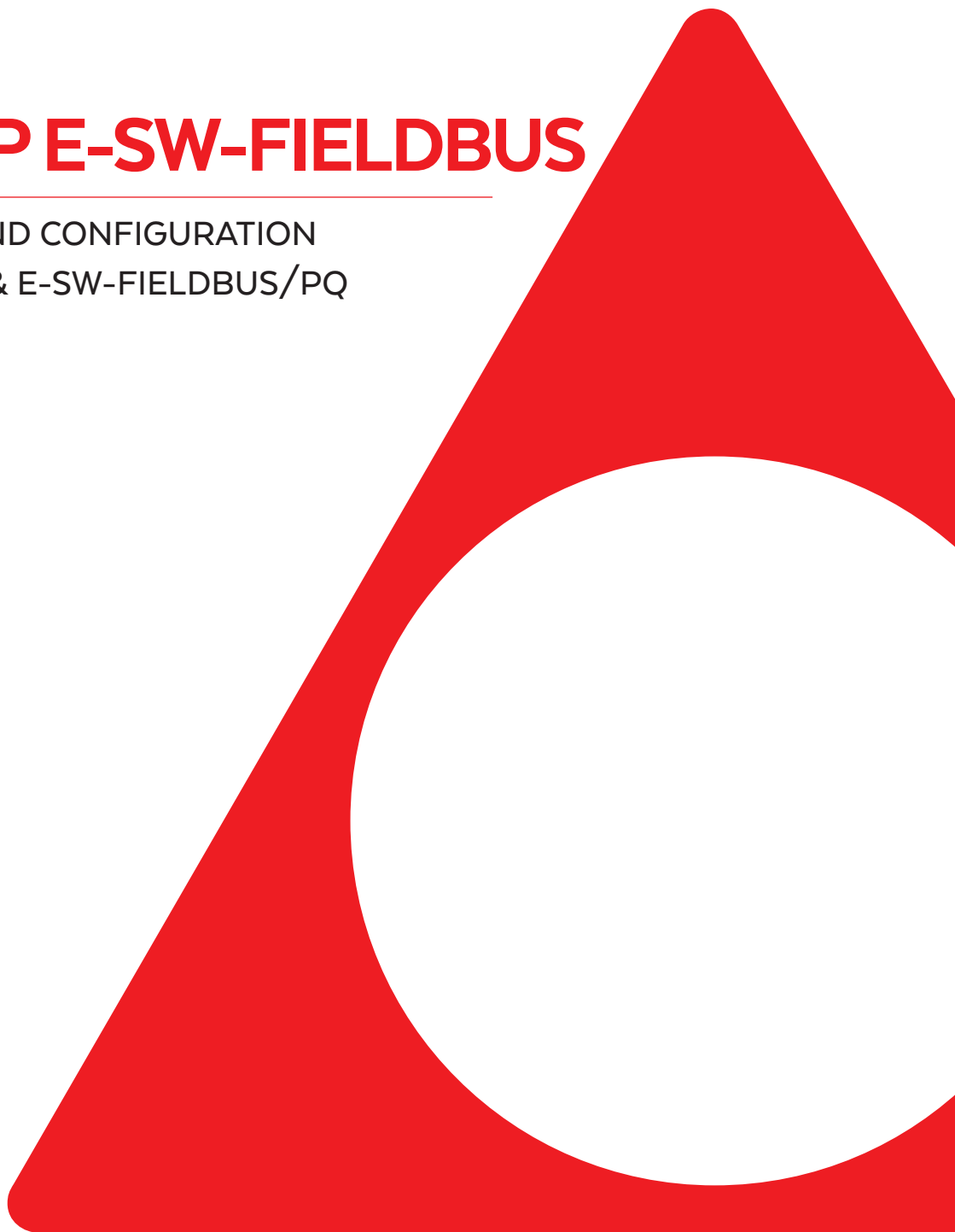

INDEX

1	GENERAL	3
1.1	About this guide.....	3
1.2	Trademarks	3
2	ABOUT E-SW PROGRAMMING SOFTWARE	4
2.1	USB memory stick contents	5
2.2	Software Activation (first supply).....	5
3	GETTING STARTED	7
3.1	Software Installation wizard.....	7
3.2	Activation Form.....	8
3.3	Cables, isolator and Adapters	9
3.4	Software start-up with connected valve - (ON-LINE mode)	10
3.5	Software start-up without connected valve - (OFF-LINE mode)	13
3.6	Access levels.....	14
3.7	Store/Restore operation	14

1 GENERAL

1.1 About this guide

This guide describes the required operations to install and configure Atos E-SW-FIELDBUS(/PQ) programming software for Atos digital electrohydraulics.

Before installing or operating the driver for the first time, read this guide.

The purpose of this guide is not to cover all the details or variations of Atos drivers and software, and it does not provide complete details for all possible working conditions; if any further information or technical support are required, please contact the Technical Sales Support of Atos Electronic Division (ele-support@atos.com).

In addition please follow up all the current regulations of the country/community where the drivers will be used.

A basic skill in using personal computers and Windows® operating system is required.

 For safety prescription, refer to the related drivers manuals.

1.2 Trademarks

All Atos trademarks ™ and ® are distinctive sign of Atos rights, know-how, and in general intellectual properties. Partial or full-unauthorized reproduction of this guide, images, logos, or casting through internet, may be object of punishment by local law. Upon delivery, all installed software is copyright-protected. The software may only be reproduced with our written consent or in accordance with the license agreement.

Windows® is a registered trademark of Microsoft Corporation

Pentium® is a registered trademark of Intel Corporation

EtherCAT® is registered trademark and patented technology, licensed by Beckhoff Automation GmbH, Germany

Beckhoff® and TwinCAT®, are registered trademarks of and licensed by Beckhoff Automation GmbH

B&R AUTOMATION STUDIO is a trademark of B&R Industrial Automation Corporation. POWERLINK is a patent-free communication system

EtherNet/IP is a trademark licensed by Open DeviceNet Vendor Association, Inc.

PROFIBUS™, PROFINET™ and PROFIsafe™, as well as the relevant logos, are registered trademarks of PROFIBUS Nutzerorganisation e.V. (PNO) SIMATIC is a registered trademark of SIEMENS AG

2 ABOUT E-SW PROGRAMMING SOFTWARE

E-SW-FIELDBUS programming software is the entry door to the Atos fieldbus technology.

E-SW-FIELDBUS/PQ is an extended software version for Atos electrohydraulics with alternated flow/pressure(force) controls.

The software automatically recognizes the connected valve model and it adapts the displayed parameters.

The graphic interface is organized in pages and levels (see 2.2) related to different specific functional groups and it allows to:

- simply access all the functional parameters of Atos digital proportional valves and drivers
- numerically adapt the factory preset parameters to the application requirements
- verify the actual working conditions
- identify and quickly solve fault conditions
- store the customized setting into the valve and into the PC

Main features

- automatic valve recognition
- multilevel graphic interface
- numeric parameters settings (scale, bias, ramp, linearization, dither, etc.)
- real-time parameters modification
- diagnostic and monitor signals
- preset data storing into the digital driver
- internal database of customized preset

Versions (supported communication interface):

- E-SW-FIELDBUS for USB Serial, CANopen, PROFIBUS, EtherCAT, POWERLINK, EtherNet/IP, PROFINET interface (NP, BC, BP, EH, EW, EI, EP)
- E-SW-FIELDBUS/PQ for USB Serial, CANopen, PROFIBUS, EtherCAT, POWERLINK, EtherNet/IP, PROFINET interface (NP, BC, BP, EH, EW, EI, EP) – for valves with SP, SF, SL alternated controls

Cables, isolator and adapter

- USB – isolator and cables (see 3.3.1)
- BTH – adapter and cables (see 3.3.2)

Minimum system requirements

- Pentium® processor 1GHz or equivalent
- Windows® XP SP3
- SVGA 16 Bit color depth in 1024x768 or higher
- 512 MB RAM
- USB port

2.1 USB memory stick contents

- Programming software
- User manuals
- Fieldbus and IO-Link configuration files



The serial number, to activate the software (see 2.2), is printed on the label placed on the USB memory stick plastic box.

The 'README_E-*.pdf' file is present in the root folder of the USB memory stick containing the software installation instructions and the 'Level passwords' to change graphic interface levels (see 2.2). 'Level Passwords' are also available in MyAtos - Download area.



E-SW-*-N programming software are not supplied with 'Level passwords' (for further information see technical table GS500).

2.2 Software Activation (first supply)

Before to perform the software activation, is mandatory login to web site Atos (see also MYATOS-GUIDE included into USB memory stick).

Please follow the steps below:

Step 1: My Atos - Register

In order to have the access in download area, perform a registration at <https://www.atos.com/en-it/register> by filling the form. Within maximum 2 working days, the registration confirmation will be sent via email from no-reply@atos.com (please also check your spam folder).

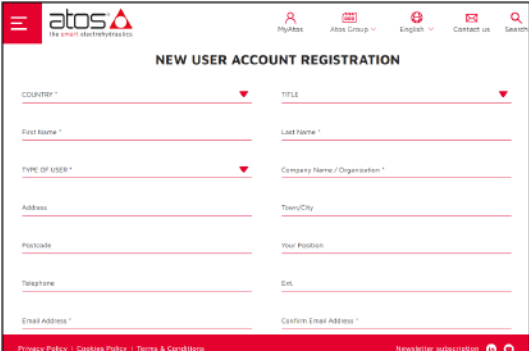

Upon first access set a personal password through the link received by email and access the My Atos section at <https://www.atos.com/en-it/login>

Upon first access download area contains:

- E-SW-BASIC
- Activation Code FREE for E-SW-BASIC
- S-SW-SETUP
- S-SW-SIZING
- USB Drivers
- Fieldbus and IO-Link Configuration Files
- User Manuals
- SWK/SWC configuration software

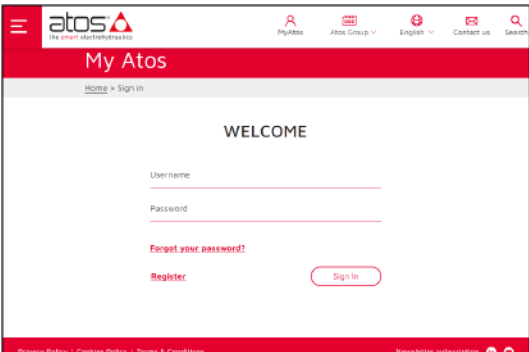

Step 2: Download area electronics - Software Registration (on first supply)

In My Atos section, at <https://www.atos.com/en-it/login> , perform login with personal username and password and then press the **Download area** button.

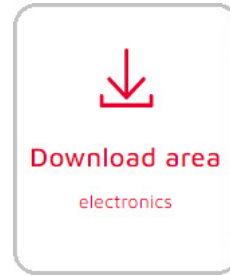

Enter the software serial number and press **Send** button, to obtain the full access to your purchased software through personal activation code. Within 2 working days Atos electronic support will update your personal area and will send to you an email with software activation code (file *.txt), see 3.2.

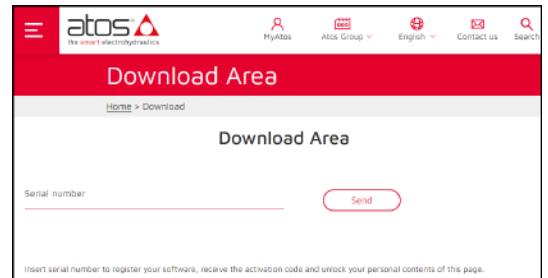

The software serial number (e.g. **01234**) is printed on the label placed on the USB memory stick plastic box received after purchase.

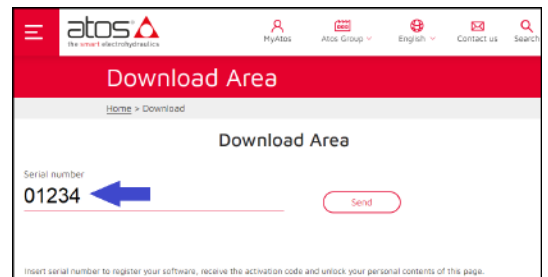
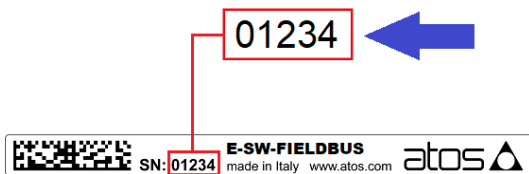



3 GETTING STARTED

This section contains a brief review of the main operations required to install E-SW software, cables and USB adapter.

3.1 Software Installation wizard

REMAKE! The software works without activation code for 10 days from the installation date: after 10 days the software stops until the user inputs the activation code.

 The login to MyAtos is mandatory to obtain the software activation code (see 2.2).

 The software must be activated to be fully operated (see 3.2).

 To install Atos software, the user must have administrator rights on the system.

 Close any open applications and do not plug any adapter to the PC before proceeding with the installation.

 If E-SW software already installed in the PC, user data are maintained and software version is updated. E-SW version lower than 5.9 is not overwrite and the it is maintained in the PC.

 When installing different E-SW software, user data are maintained and all software versions are updated (e.g. Installing E-SW-FIELDBUS/PQ will update also E-SW-FIELDBUS if installed).

Enter USB memory stick into PC USB port and run file "Atos-SW.exe": the dedicated graphic interface will open for the software installation and for others available contents.

Press **Software Installation** button and follow displayed instructions to complete the process.

Once that installation is completed the software starts at **Level 1 – Basic** (to change access level see 2.2).

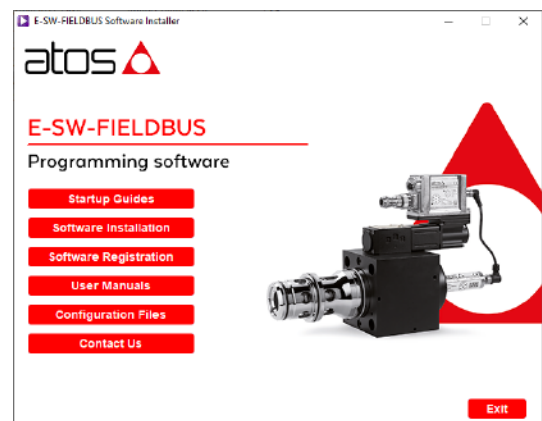

3.2 Activation Form

When the software is started for the first time, a message shows how many days are left before the software stops and it ask to perform the activation.

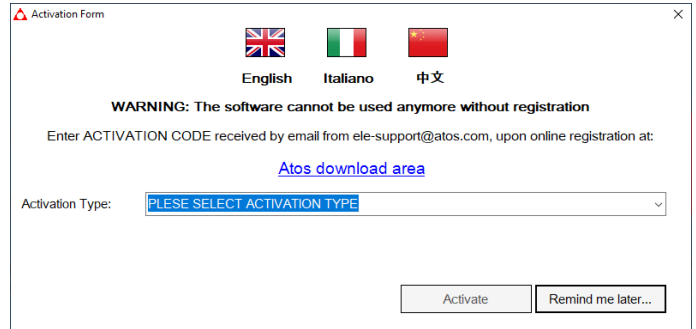

Select an activation type:

- **Activation Type:** select **FREE BASIC**
- Press **Activate** button



Selecting **FREE BASIC** will be activated only E-SW-BASIC version

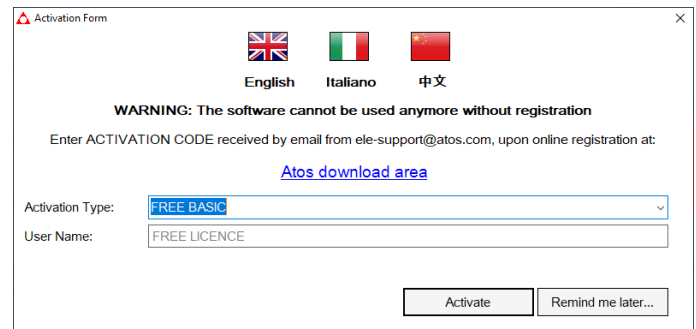

- **Activation Type:** select **FULL VERSION**
- **User Name:** enter the user name contained in the *.txt file received in attachment via email sent by ele-support@atos.com during registration
- **Activation Code:** enter the activation code contained in the *.txt file received in attachment via email sent by ele-support@atos.com during registration
- Press **Activate** button

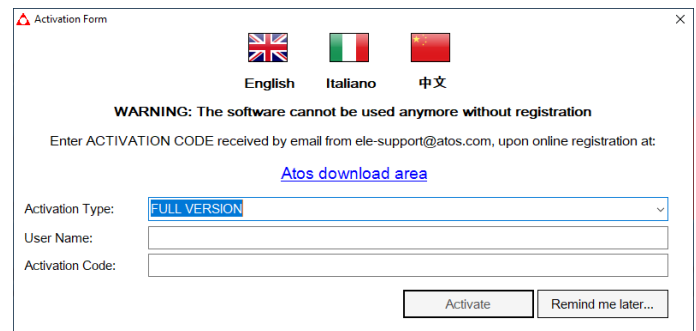

3.3 Cables, isolator and Adapters

USB cables, isolator and adapter are required to connect E-SW software to digital electronics. Cables, isolator and adapters must be ordered separately, for detailed description please refer also technical table GS500.

3.3.1 USB – isolator and cables

E-SW software permit valve's parameterization through USB port.

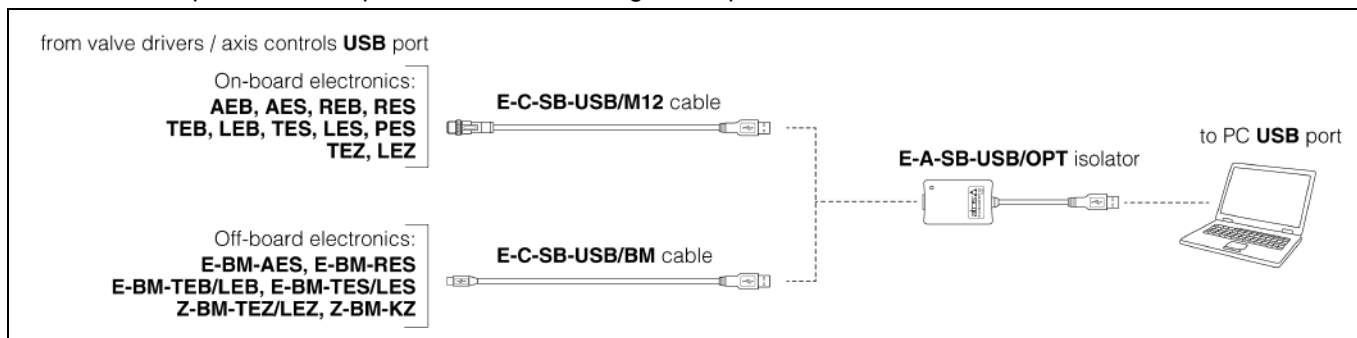

⚠ WARNING: the USB port of drivers/axis cards is not isolated and use of USB isolator adapter is highly recommended!

Wrong earthing connections may cause high potential difference between GNDs, generating high currents that could damage drivers/axis cards or the connected PC.

💡 E-SW-FIELDBUS allows EtherCAT, POWERLINK, EtherNet/IP and PROFINET drivers programming only through USB or Serial communication port.

3.3.2 BTH – adapter and cables

E-SW software permit valve's parameterization through Bluetooth.

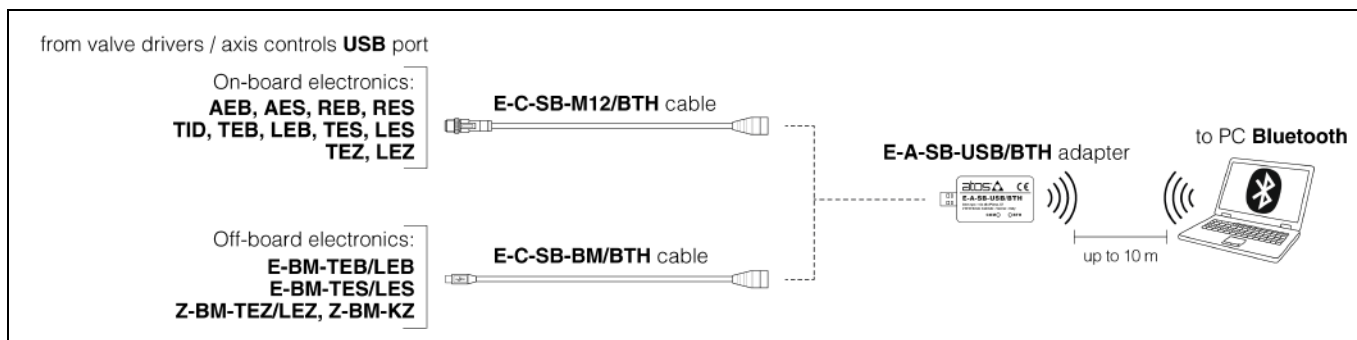

⚠ Bluetooth adapter is not compatible with E-BM-AES and E-BM-RES drivers

💡 To fully operate the E-SW software and the digital electrohydraulic, please refer to the relevant documentation (see 2.1).

3.4 Software start-up with connected valve - (ON-LINE mode)

To completely verify the programming tools installation and configuration, it is required to:

- connect valve to the PC (see 3)
- apply power supply to the connected valve (refer to specific driver operating manual – see 2.1)
- launch E-SW software by program shortcut on Windows desktop or start menu -> programs
- if software cannot start-up with the valve (ON-LINE mode) try to operate without the valve (OFF-LINE mode - see 3.5)

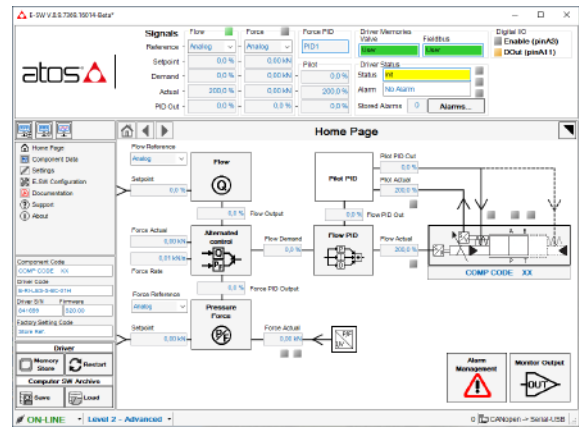

3.4.1 Driver connection not available

At start-up the E-SW software searches automatically an available interface to communicate with the connected valve/driver. If the connection is not valid, it will display the software page shown at side. The user can choose how to proceed:

- **ON-LINE** to retry the connection in two different modalities:
 - Wizard procedure** – see 3.4.2
 - Manual procedure** – see 3.4.3
- **OFF LINE** - see 3.5

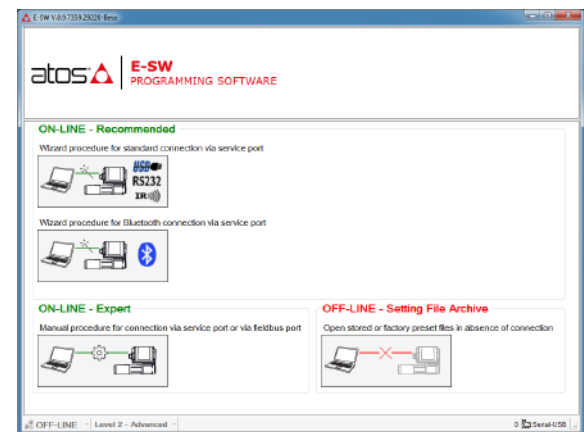

3.4.2 ON-LINE - Recommended

Verify adapter and cables connection from PC to driver:
 press button ① to start the automatic wizard procedure and press **CONNECT VIA USB TO BC, BP, EH, EW, EI, EP** button ②.

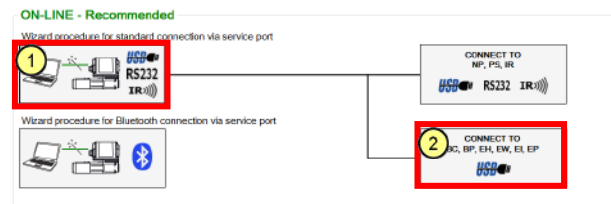

💡 **BC** = CANopen; **BP** = PROFIBUS; **EH** = EtherCAT; **EW** = POWERLINK; **EI** = EtherNet/IP; **EP** = PROFINET IRT

3.4.3 ON-LINE - Expert

Verify adapter and cables connection from PC to driver:
 press button ① to perform the manual procedure (see 3.4.4 for detailed description).



⚠️ E-SW communication settings can be modified only in OFF-LINE status.

3.4.4 Communication Parameters [expert users only]

In Communication software page is possible set the communication parameters.

Interface

Use the control ① to selects the communication as the active interface to the connected driver in fieldbus execution through USB connection (see 3.3.1):

- Serial-USB for CANopen - see 3.4.5
- Serial-USB for PROFIBUS - see 3.4.5
- Serial-USB for EtherCAT - see 3.4.5
- Serial-USB for POWELINK - see 3.4.5
- Serial-USB for EtherNet/IP - see 3.4.5
- Serial-USB for PROFINET IRT - see 3.4.5
- CANopen
- PROFIBUS

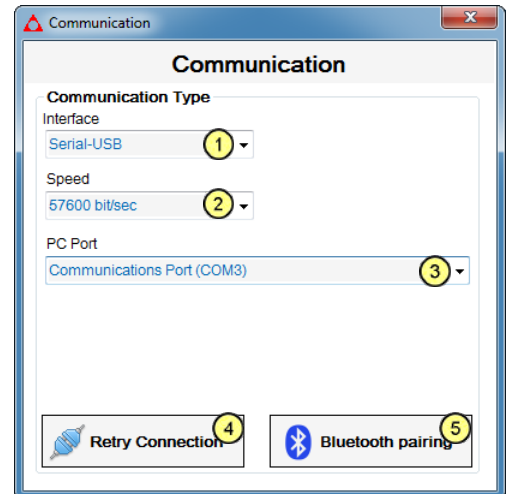

Speed

The control ② allows the user to select the speed of the communication with the connected driver: high speeds allow a faster update of displayed data but may cause Timeout communication errors.

PC port

The control ③ allows the user to select, which USB port has to be used to communicate with the connected driver among the available USB ports.



Valves connected with USB cable to the PC are recognized as **STMicroelectronics Virtual COM Port**.

Retry Connection

Press button ④ to retry the connection.



Once verified that all wirings are correct and pressing ④ the driver connection is still not available, please contact Atos technical support (see 3.5.2).



E-SW communication settings can be modified only in OFF-LINE mode.





When installing new E-SW software version check the communication configuration settings.



Bluetooth pairing

The button ⑤ perform the wizard procedure for Bluetooth connection. For more information please refer STARTUP BLUETOOTH guide.

3.4.5 Fieldbus connection via Serial-USB

 This procedure is available only for valve connected through E-C-SB-USB/M12 or E-C-SB-USB/BM cable (see 3.3.1). Use of E-A-SB-USB/OPT isolator adapter is highly recommended for drivers and PC protection.

To connect via USB the driver in fieldbus execution use the control  to select the fieldbus communication as the active interface, according to the connected valve.

- select E-SW speed  and PC port  to communicate with the connected valve

 By default the valves/drivers with Serial-USB communication interface are delivered with speed 57600 bit/sec.

- press button  to try to connect with the valve using current communication settings

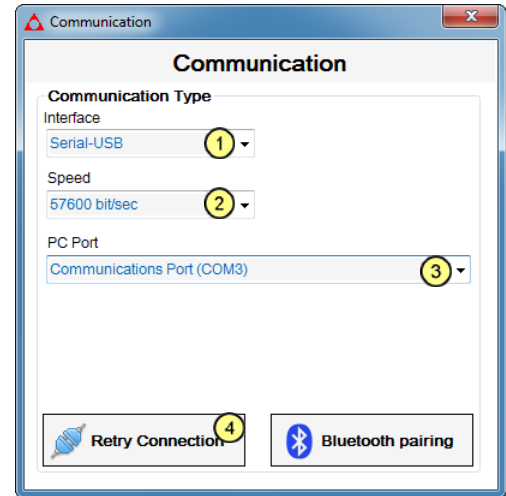

 Valves connected with USB cable to the PC are recognized as **STMicroelectronics Virtual COM Port**.

3.5 Software start-up without connected valve - (OFF-LINE mode)

If valve, adapter or cables is not available or ON-LINE mode cannot be achieved (see 3.4), is still possible to operate E-SW software to verify correct installation and its operation.

Press **SETTING FILE ARCHIVE** button ①, to access on **Computer SW Archive - Setting File** software page and select one of the available factory preset setting files.

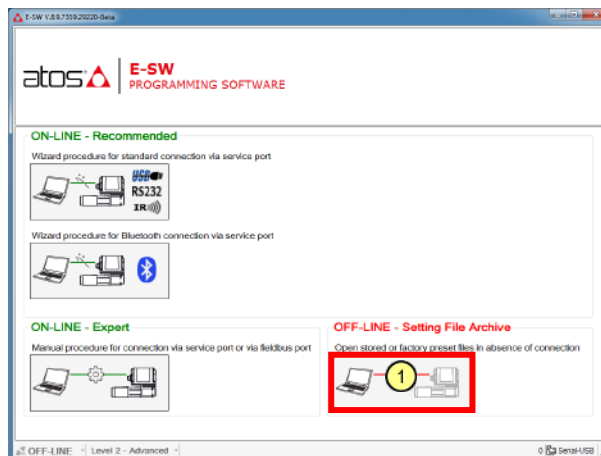

This operation allows to load a 'Setting Files' from the PC hard-disk into the programming software.

- Select: **User Archive** ②, **Atos Archive** ③ or **Atos Old Series Archive** ④
- Select one of the available 'Setting Files' ⑤
- Click-on **Load** button ⑥

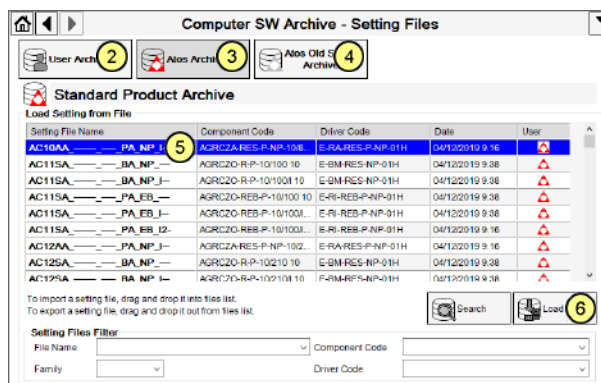

Refer specific driver operating manual (see 2.1) to completely operate with driver parameter.

3.5.1 Documentation

In OFF-LINE mode it is possible download the user manuals of the related valves.

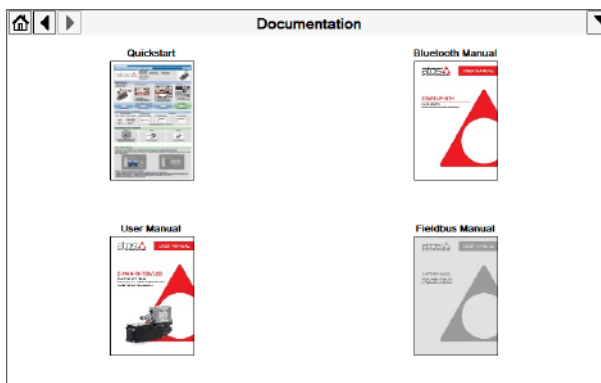

3.5.2 Support

In OFF-LINE mode you can request technical support service of Atos Electronic Division to solve installation problems.

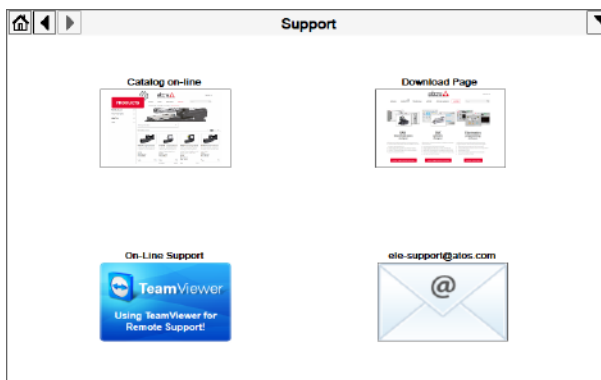

3.6 Access levels

The E-SW software graphic interface is organized in multiple pages and levels related to different specific functional groups; use the lowest access level that matches the application requirements to obtain the simplest software interface.

The indicator ① allows the user to verify the actual software level status.

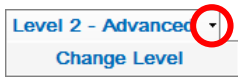

To change software level status click on black arrow and press 'Change Level' button

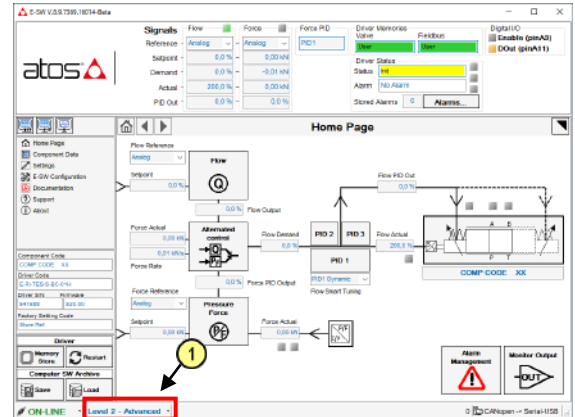

Actual Level

The indicator ② displays currently selected access level of the software graphic interface.

Level Password

The control ③ allows the user to input the password for the desired level of the graphic interface; level passwords are available in MyAtos - Download area (see 2.2) or in the 'README_E-*.pdf' file present in the root folder of the USB memory stick (see 2.1).

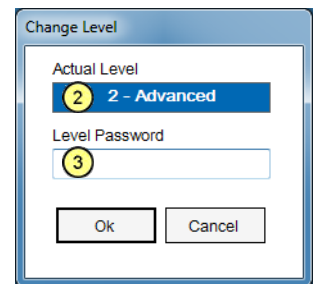

Actual Level Configuration

- 0 - Visualization** only visualization - not allowed parameters changes
- 1 - Basic** user with low experience in driver settings can handle basic parameters
- 2 - Advanced** free access to all standard parameters

A further level password is available only upon attending a dedicated training in Atos and upon submitting a detailed description of the application requirements to ele-support@atos.com.

- 3 - Expert** free access to all the driver parameters to specially customize the valve behaviour

3.7 Store/Restore operation

WARNING!

The user must always observe all information and instructions reported in FS900 or FX900 tech table to avoid damage and injury. Before operating/connect the valve with the programming software the user must read the user manual carefully: programming software can change/inhibit the behaviour of the valve causing damage and injury!

During store/restore operations of the electronic driver/axis control permanent memory:

- current to valve solenoid is switched off: operate store/restore with no active valve regulation in the system
- do not turn off power supply: driver/axis control parameter lose may occur

Faults of driver/axis control may compromise safety or change operating conditions, shut down the driver/axis control immediately and notify qualified personnel.



www.atos.com