

E-MAN-AAT

ATOS AUTOMATIC TEST SOFTWARE
INSTALLATION AND CONFIGURATION
FOR RC02 TESTING BENCH



INDEX

1	GENERAL	3
1.1	About this user manual.....	3
1.2	Documentation	3
1.3	Safety prescriptions	6
1.4	About programming software	8
1.5	Test procedure steps.....	8
2	ABOUT RC02 TESTING BENCH	9
2.1	Overview.....	9
2.2	Hardware installation	12
2.3	Connections description	16
3	DRIVERS AND SOFTWARE INSTALLATION	24
4	ABOUT E-SW AND Z-SW SOFTWARE	26
4.1	Main window.....	26
4.2	Communication area	29
4.3	Multifunction area [Computer SW Archive]	31
5	ABOUT ATOS AUTOMATIC TEST SOFTWARE	34
5.1	Main window.....	34
5.2	Configuration window	35
5.3	AAT– First Startup	36
5.4	Test Execution.....	41
6	SETTING FILE DOWNLOAD PROCEDURE	51

1 **GENERAL**

1.1 **About this user manual**

This manual describes the required operations to testing and calibration the Atos drivers and axis controls through Atos Automatic Test (AAT) programming software for PC.

Before installing or testing the driver for the first time, read this manual.

This manual does not provide complete details for all possible working conditions; if any further information or technical support are required, please contact the Technical Sales Support of Atos Electronic Division (ele-support@atos.com).

The manual contains important safety instructions (see 1.3), whose knowledge is required to:

- avoid hazards and dangers
- minimize service and downtime
- increase the working and reliability of the driver

In addition please follow up all the running regulations of the country/community where the drivers will be used.

A basic skill in using personal computers and Windows® operating system is required.

1.2 **Documentation**

Additional information about valves, electronic drivers/axis controls and Atos software can be found into the Atos Catalog on-line or in the MyAtos - Download area (see 1.2.2).

1.2.1 **Related documentations**

- QS-RC02 Quickstart RC02 – testing bench
- E-MAN-* Operating manuals for digital drivers
- Z-MAN-* Operating manuals for digital axis controls
- GS500 Programming tools for digital electronics - technical table

1.2.2 MyAtos area – Download area electronics

Latest releases of the programming software, manuals, USB drivers, configuration files and access passwords are available on MyAtos at www.atos.com.

 It is mandatory perform the login to web site Atos. See the steps below.

Step 1: My Atos – Register – New user account registration

In order to have the access in MyAtos, perform the registration at <https://www.atos.com/en-it/register> by filling the form. Within maximum 2 working days, the registration confirmation will be send via email from no-reply@atos.com (please check also your spam folder).

Upon first access set a personal password through the link received by email and access the MyAtos section at <https://www.atos.com/en-it/login>

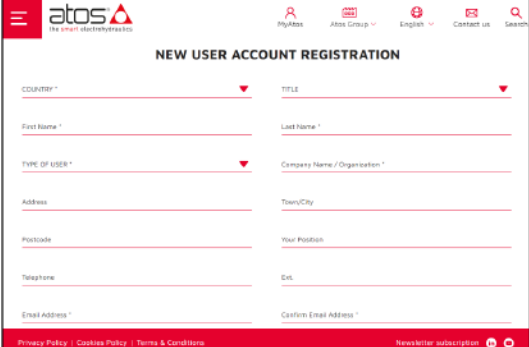

Step 2: Download Area

In MyAtos area, perform login with personal username and password and then press the **Download area electronics** button.

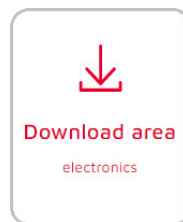
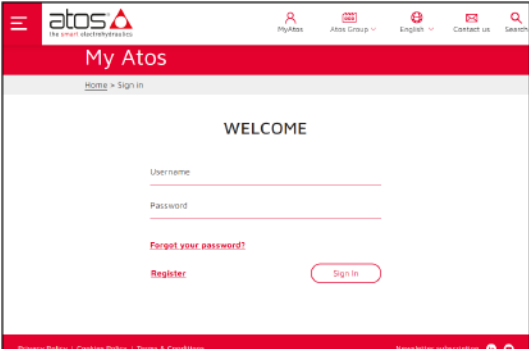
With the first access to the download area, the following will be available:

- E-SW-BASIC
- Activation Code FREE for E-SW-BASIC
- S-SW-SETUP
- S-SW-SIZING
- USB Drivers
- Fieldbus Configuration Files
- User Manuals
- SWK/SWC configuration software

 An automatic e-mail service will inform all users of registered software whenever new software updates are available.

 The E-SW and Z-SW software must be activated, see 1.4.2

1.2.3 Trademarks

All Atos trademarks [™] and [®] are distinctive sign of Atos rights, know-how, and in general intellectual properties. Partial or full-unauthorized reproduction of this manual, images, logos, or casting through internet, may be object of punishment by local law.

Upon delivery, all installed software is copyright-protected. The software may only be reproduced with our written consent or in accordance with the license agreement.

Windows[®] is a registered trademark of Microsoft Corporation

Pentium[®] is a registered trademark of Intel Corporation

EtherCAT[®] is registered trademark and patented technology, licensed by Beckhoff Automation GmbH, Germany

Beckhoff[®] and TwinCAT[®], are registered trademarks of and licensed by Beckhoff Automation GmbH

B&R AUTOMATION STUDIO is a trademark of B&R Industrial Automation Corporation. POWERLINK is a patent-free communication system

EtherNet/IP is a trademark licensed by Open DeviceNet Vendor Association, Inc.

PROFIBUS[™], PROFINET[™] and PROFIsafe[™], as well as the relevant logos, are registered trademarks of PROFIBUS Nutzerorganisation e.V. (PNO) SIMATIC is a registered trademark of SIEMENS AG

IO-Link is a registered trademark of PROFIBUS User Organization (PNO)

1.3 Safety prescriptions

1.3.1 General warning

- all information and instructions reported in this manual and in the supplementary documentation (see 1.2.1), must always be observed to avoid damage and injury

Hazardous situations may occur whenever the driver/axis control:

- is not properly transported and stored
- is altered or modified
- is not installed, commissioned and operated by qualified persons
- is not used properly

1.3.2 Personnel selection and qualification

Qualified personnel, in the sense of this document, are:

- persons properly trained and authorized to install, start-up and operate the digital driver/axis control in accordance with the established safety prescriptions and procedures
- persons who, based on their technical/standards knowledge and training, are able to evaluate their tasks, to recognize potential hazards and to carry out the correct safety measures

1.3.3 Electrical installation warning

Following recommendations on electrical installation must be always observed:

- Switch-off power supply before connecting or disconnecting the driver/axis control
- Do not use electrical signals of the driver/axis control (e.g. reference, monitor and enable signals) for safety purpose
- Take care when switch-on/off the driver/axis control because it could produce uncontrolled movements of the actuators operated by the driver/axis control
- Always shield analog signal wirings
- Use low-capacitance cables and do not use intermediate connections
- Do not wire any power cables close to control electronics or command/signals wirings
- Protect the driver and other control electronics from electromagnetic noises
- Maintain a proper distance from antenna lines, RF devices and radio equipment



WARNING: drivers/axis controls USB ports are not isolated!

Use of USB isolator adapters (see 1.3.4) are highly recommended for PC and RC02 testing bench protection: wrong earthing connections may cause high potential difference between GNDs, generating high currents that could damage the PC and RC02 testing bench connected to integral closed loop drivers/axis controls. Before connecting Atos driver/axis control and RC02 testing bench to PC USB ports, check correct potential level of earthing connection.

1.3.4 USB isolator adapter E-A-SB-USB/OPT

The USB isolator adapter E-A-SB-USB/OPT can be installed between USB cables and PC USB ports.

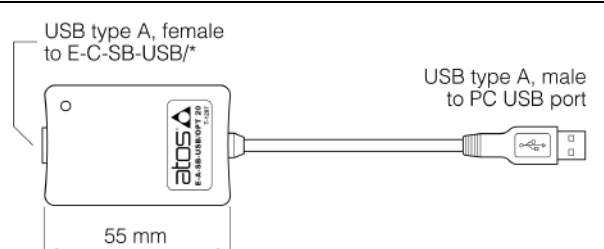
TECHNICAL SPECIFICATIONS	
USB 2.0 Full speed (12 MBps)	
electrical isolation 3 kV	
temperature range, -40° ÷ +80°	
external power supply not required	
PC drive not required	
status LED	

1.3.5 Electromagnetic compatibility

Atos electronic driver/axis control and proportional valves have been tested according to EMC directives.

The EMC Directive identifies the ability of a device, equipment or system to function in an electromagnetic environment in a satisfactory manner (immunity), without produce intolerable electromagnetic interferences into any equipment in same environment (emission). For further information please refer to specific technical tables for related product code.

 The electromagnetic compatibility of the drivers/axis controls is valid only if wirings are realized according to the recommended electric connections.

 Electromagnetic fields of machine environment may be different from test conditions: always verify the device functionality once installed.

1.3.6 Electrostatic discharge protection

Electrostatic discharge (ESD) can damage electronic components of the driver/axis control; to prevent damage observe the following recommendations:

- Discharge static voltage from your body before handling the valve/driver/axis control
- Work in a safe environment (do not use any device or surface that can generate or hold static charge)
- Avoid to touch any exposed pins or electronic components



1.4 About programming software

AAT, E-SW-FULL and Z-SW-FULL programming software are supplied in USB key format (see 1.4.3) and it can be easily installed on a desktop or notebook.

1.4.1 Minimum PC requirements for Atos software

- Celeron® I5 processor or equivalent
- Windows® 7 SP1
- SVGA 16 Bit color depth in 1024x768 or higher
- 1Gb RAM
- USB port

1.4.2 E-SW and Z-SW software activation (first supply)

The E-SW and Z-SW software must be activated by MyAtos after web registration on www.atos.com (see 1.2.2), using the serial number **99999**

In My Atos section, at <https://www.atos.com/en-it/login> perform login with personal username and password and then press the **Download area** button.

Insert the software serial number **99999** and press **Send** button, to obtain the full access to your purchased software through personal activation code. Atos support service will send an email with software activation code (file *.txt).



 Upon web registration user receives via email the Activation Code (purchased software license). File *.txt' in attachment containing 'User Name' and 'Activation Code' for software activation.

1.4.3 SW-KEY contents

- USB drivers
- Installer of E-SW-FULL software
- Installer of Z-SW-FULL software
- Installer of AAT software
- Documentations



1.5 Test procedure steps

Please refer the follow step, before to start with any operations with RC02 testing bench:

Step 1:

- pick up all the information about the problem claim of the customer
- test the complete valve on a hydraulic bench without doing any change
- try to understand if the issue is due to mechanical part or electronic driver/axis control
- evaluate if it is necessary to do automatic test on driver/axis control

Step 2:

- remove driver/axis control from valve or electrical cabinet
- for digital driver/axis control save always the customer parameter using E-SW or Z-SW software
- test the driver/axis control using the RC02 testing bench (see 2)

Step 3:

- Start the test procedure (see 5.3)
- For digital driver download the factory valve setting file using E-SW or Z-SW software (see 6)

2 ABOUT RC02 TESTING BENCH

The RC02 testing bench is a fundamental tool to able to test Atos drivers and axis controls.

Following a brief description of the main devices and tools supplied with the kit: for further information, please refer QS-RC02-0 Quickstart (see 1.2).

2.1 Overview

ESP-RC02-P – Programmable DC power supply – RIGOL DP832

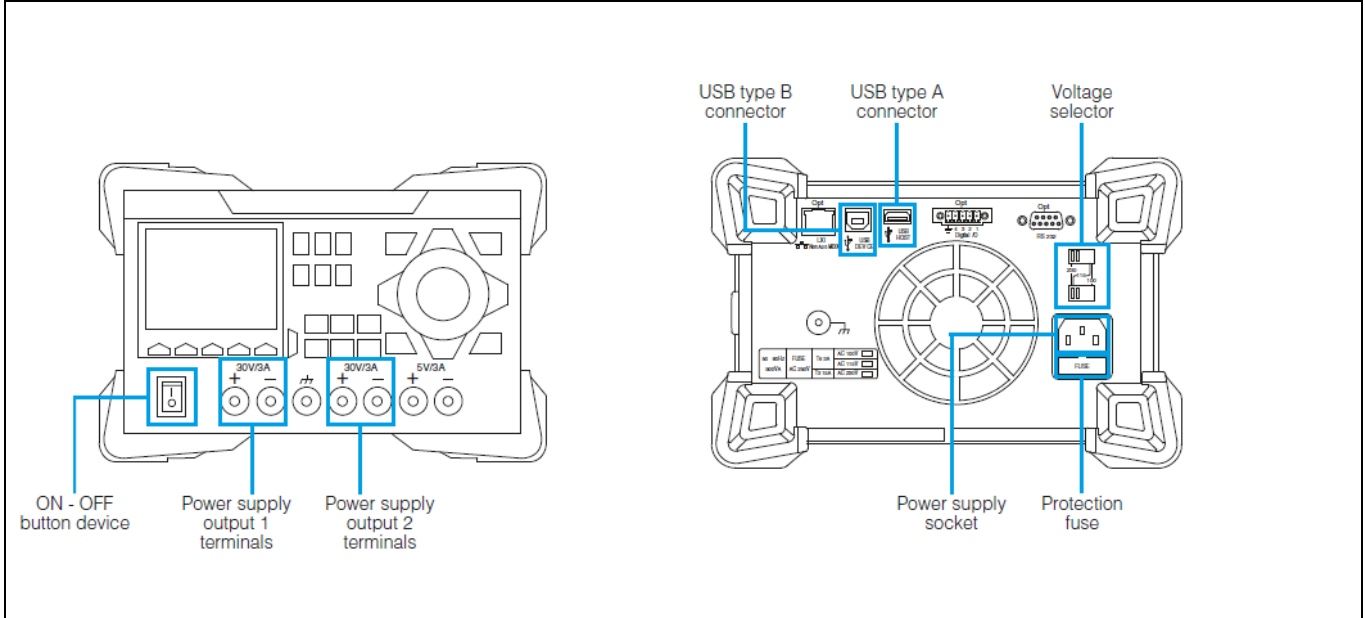

ESP-RC02-M – Main test bench

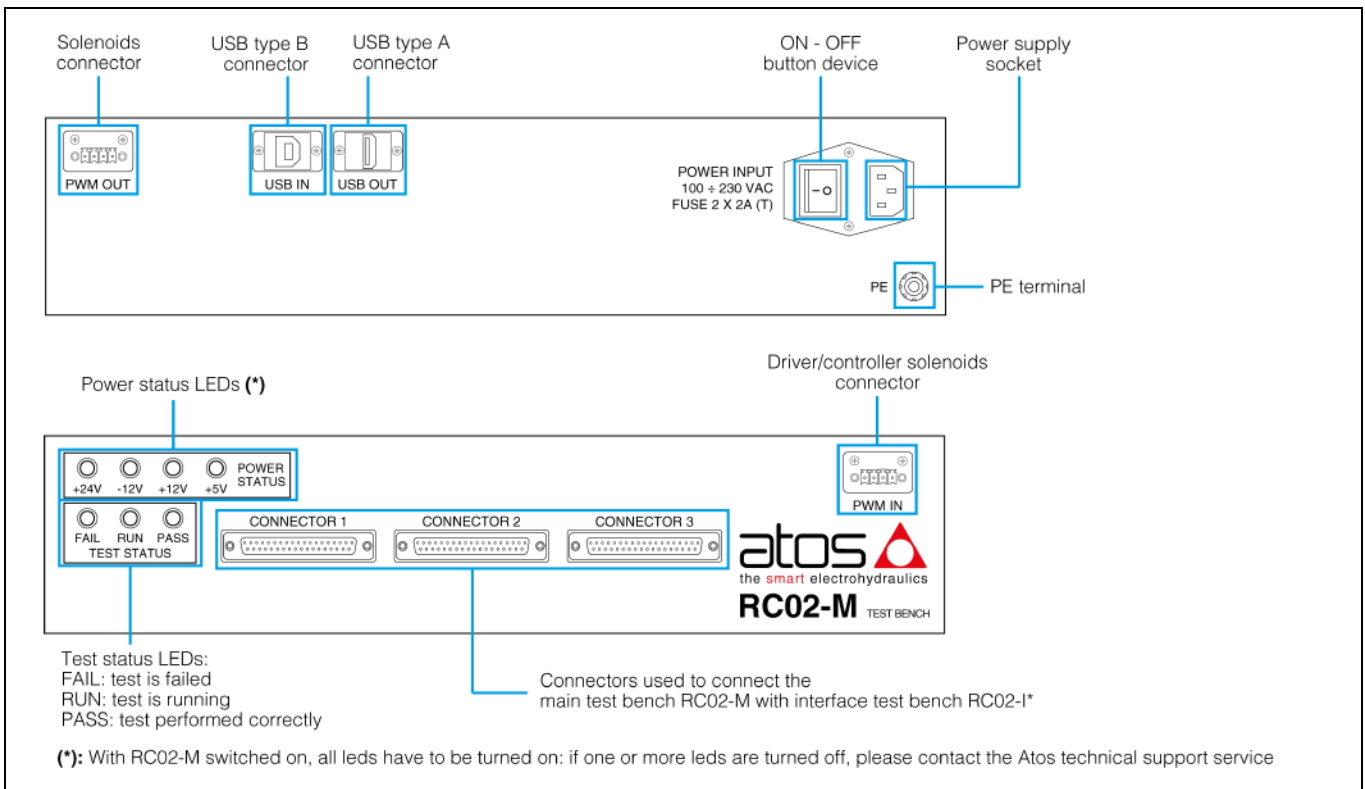

ESP-RC02-S – Solenoids

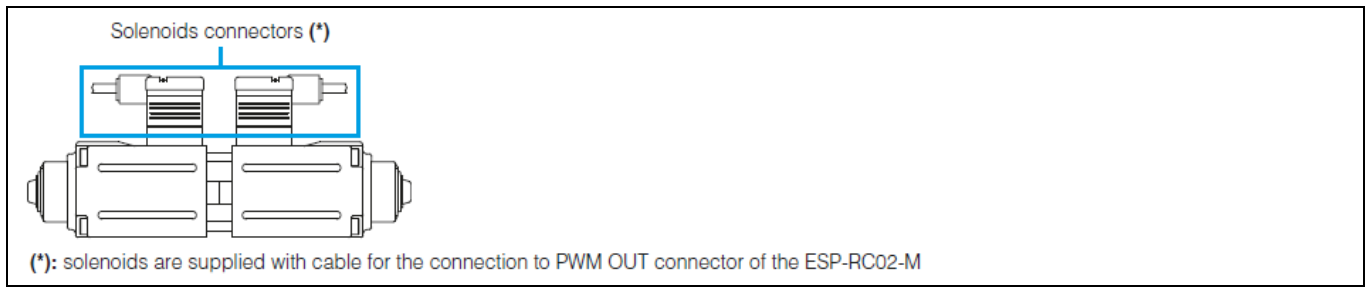

ESP-RC02-I1 – Interface 1 test bench

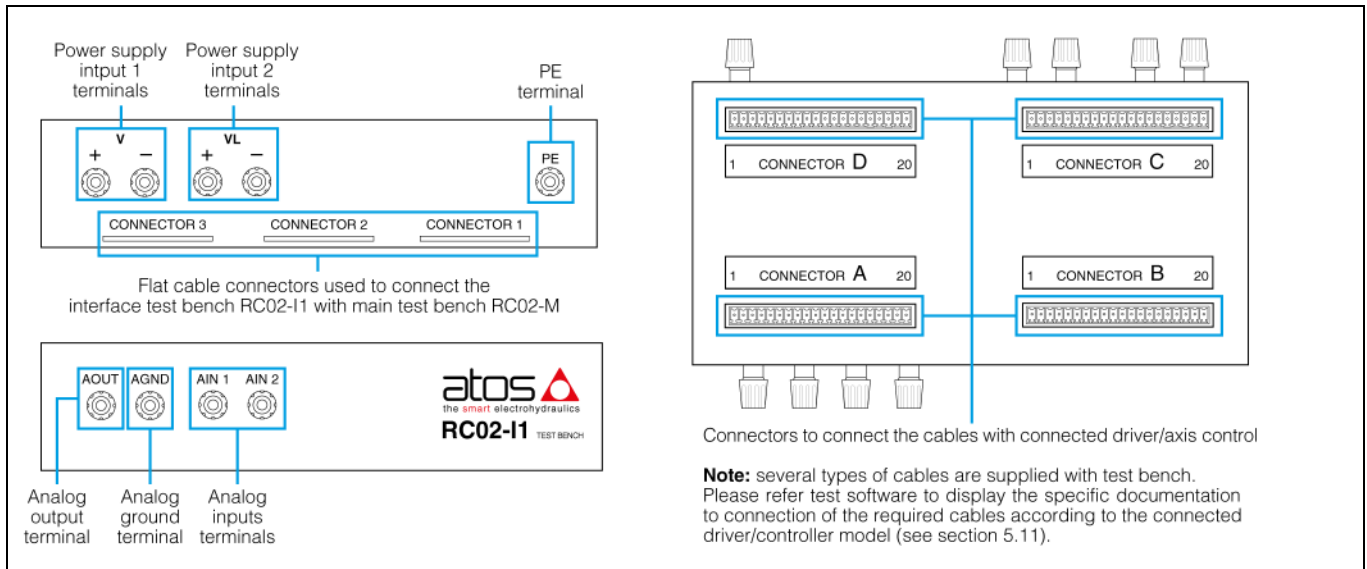

ESP-RC02-I2 – Interface 2 test bench

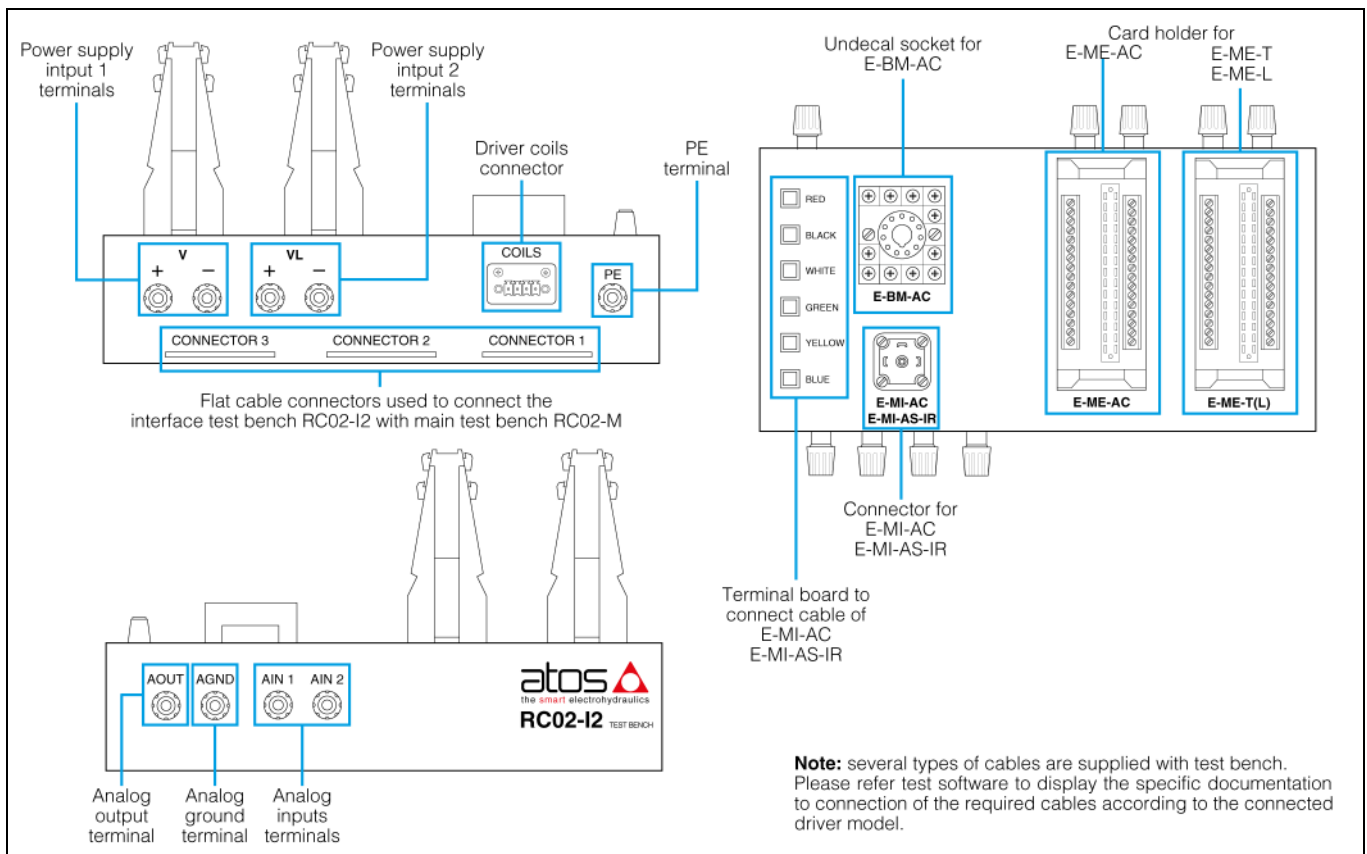

ESP-RC02-I3 – Interface 3 test bench

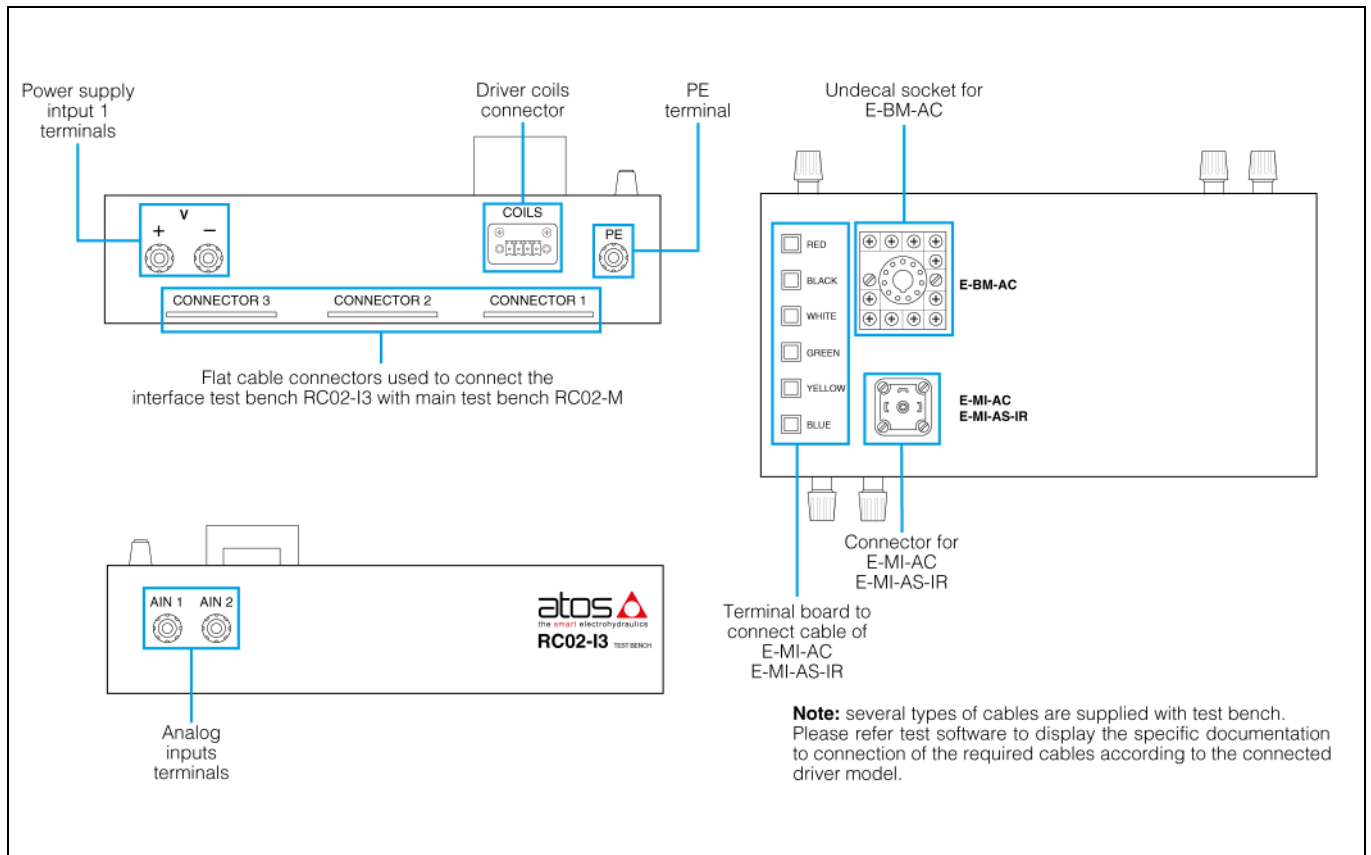

2.2 Hardware installation

1. Set voltage and replace fuse on **ESP-RC02-P** - programmable DC power supply RIGOL DP832

WARNING! Set voltage according to the country/community where the ESP-RC02-P will be used.

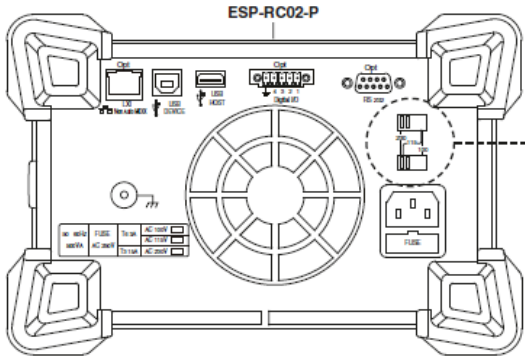

VOLTAGE SELECTOR SETTINGS

230 VAC

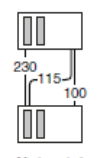

115 VAC

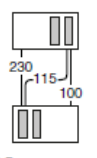

100 VAC

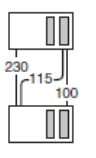

Note: default 230 VAC

WARNING! Check and eventually replace the fuse supplied with the ESP-RC02-P, according to the input voltage.

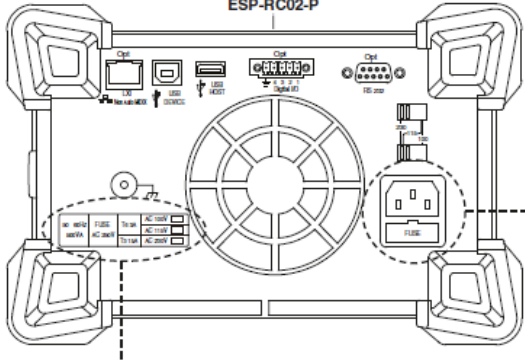

FUSE REPLACING

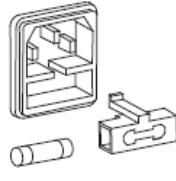

1. switch off the ESP-RC02-P
2. remove the cable ESP-RC02-C-220V-EU
3. use a straight screwdriver to extract the fuse holder
4. remove gently out the fuse

Refer label on rear panel of the instrument for the fuse specifications:

50 - 60Hz 500VA	FUSE:	T6.3A	AC 100V	<input type="checkbox"/>
	AC 250V	T3.15A	AC 115V	<input type="checkbox"/>
			AC 230V	<input type="checkbox"/>

Note: default T3.15A AC 230V

2. Connect power supply cable **ESP-RC02-C-220V-EU** on **ESP-RC02-P**

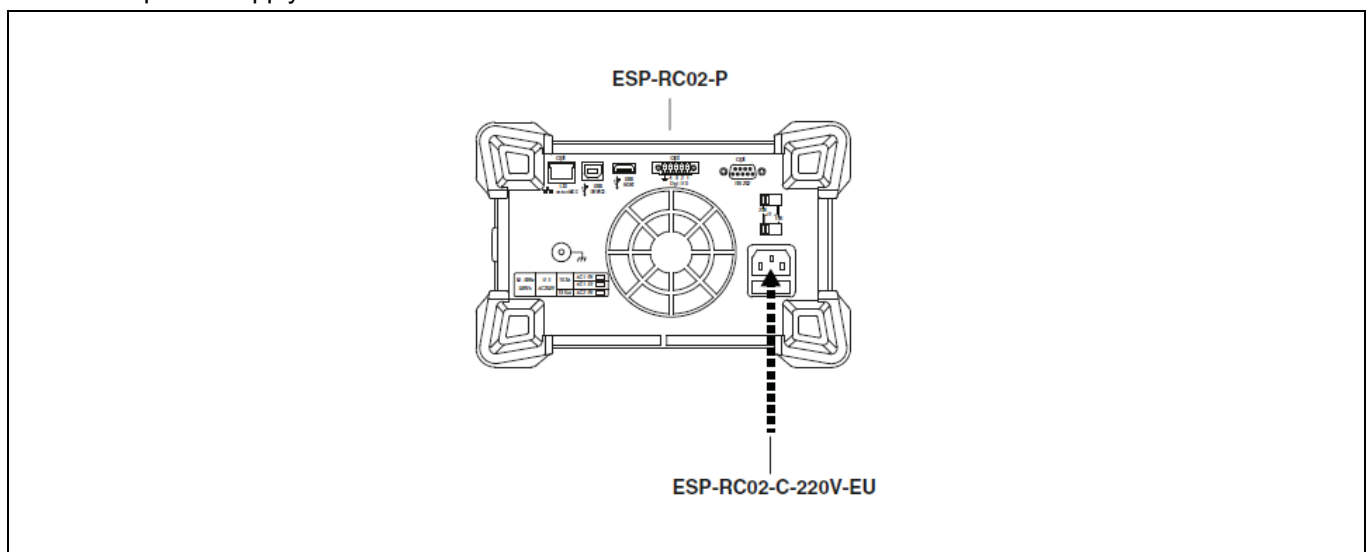

3. Connect power supply cable **ESP-RC02-C-220V-EU** on **ESP-RC02-M** – Main Test Bench

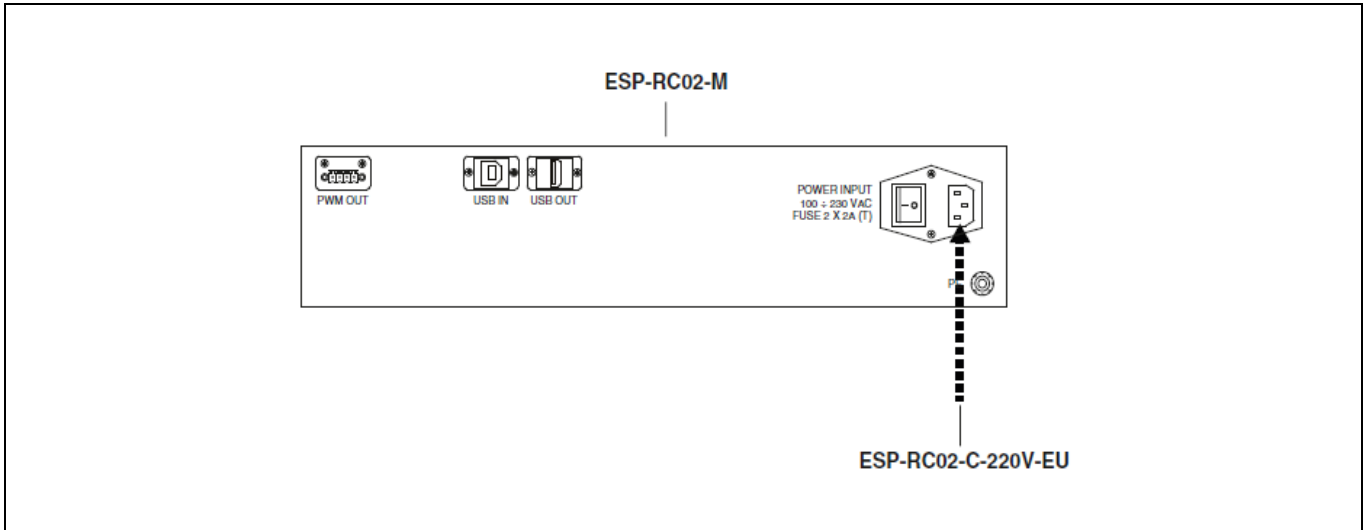

4. Connect PE cable **ESP-RC02-C-PE** from **ESP-RC02-M** to **ESP-RC02-I1** – Interface 1 Test Bench

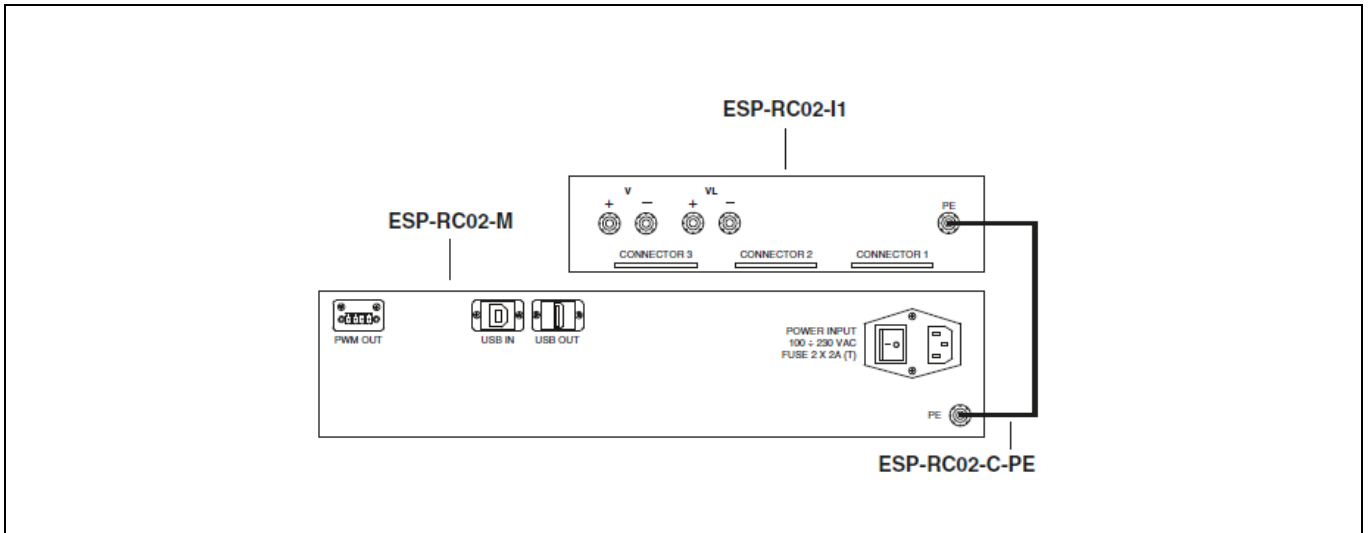

5. Connect PE cable **ESP-RC02-C-PE** from **ESP-RC02-M** to **ESP-RC02-I2** – Interface 2 Test Bench

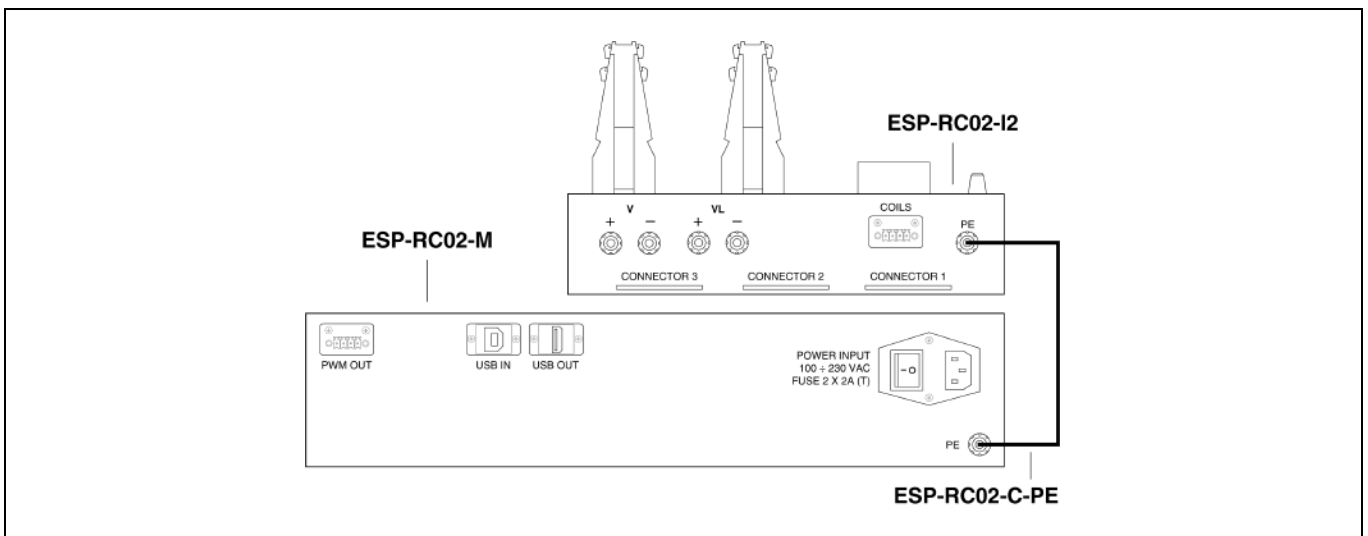

6. Connect PE cable **ESP-RC02-C-PE** from **ESP-RC02-M** to **ESP-RC02-I3** – Interface 3 Test Bench

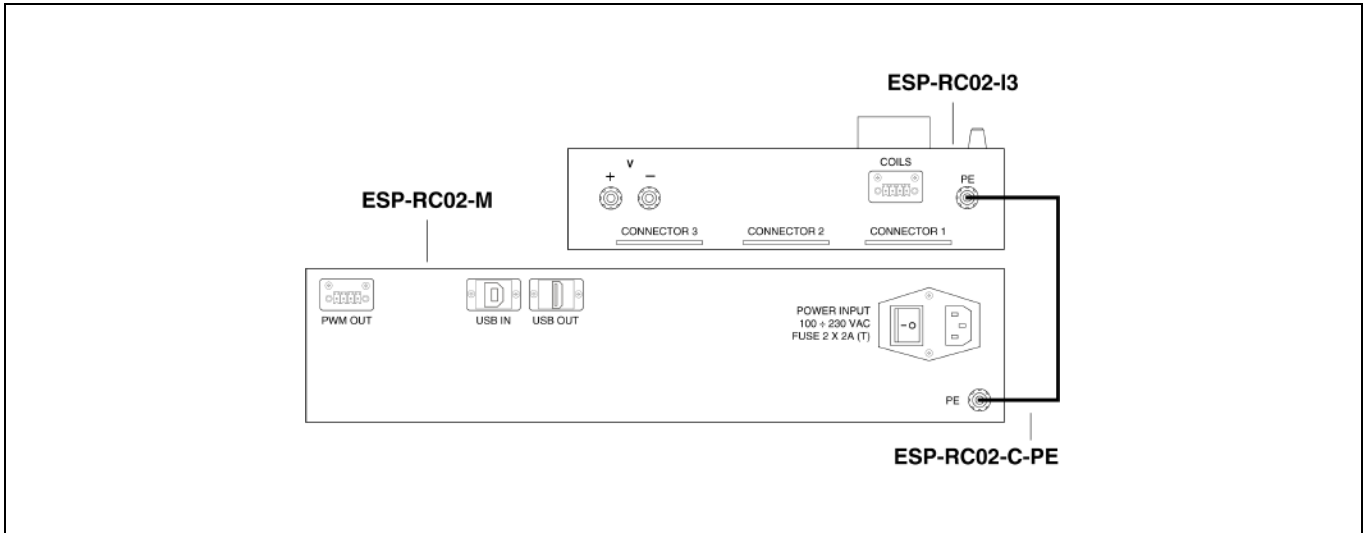

7. Connect USB cable from **ESP-RC02-P** to **ESP-RC02-M**

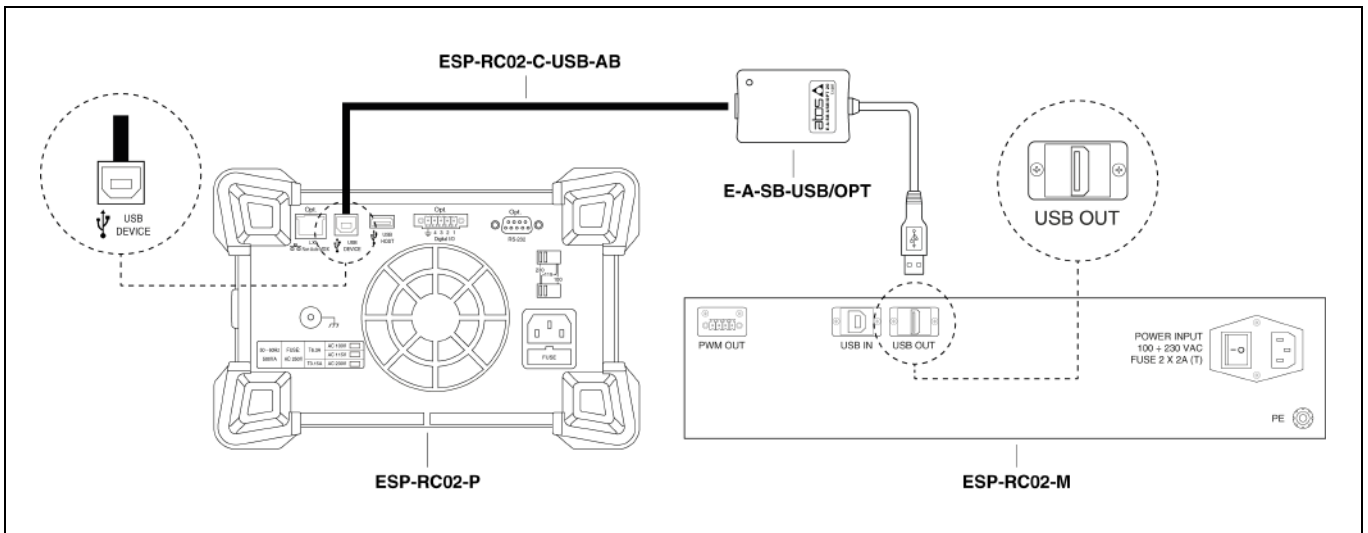

8. Connect USB cable from **ESP-RC02-M** to **PC**

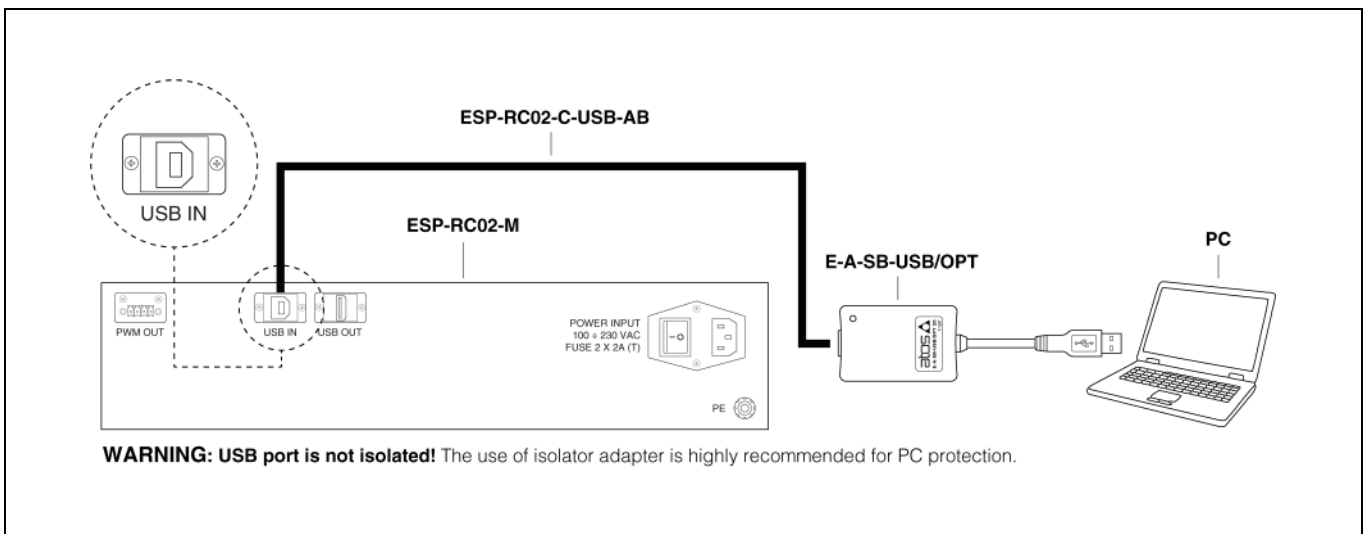

9. Connect solenoids **ESP-RC02-S** to **ESP-RC02-M**

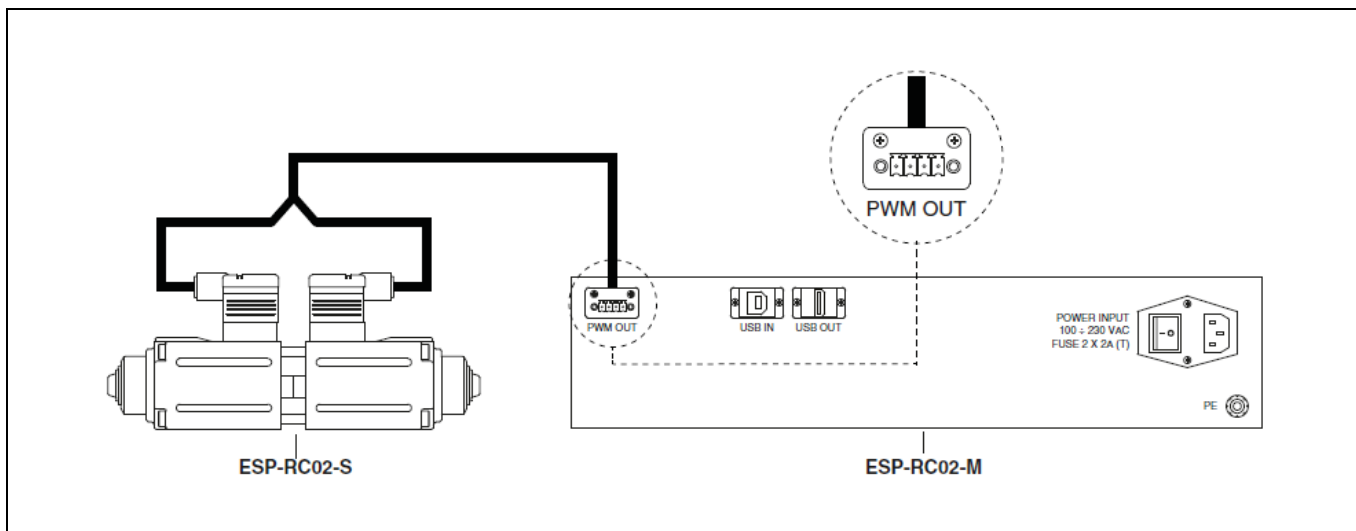

2.3 Connections description

Different types of connectors, cards holder, undecal socket and terminal boards are available on ESP-RC02-I* test bench interfaces to perform all connections with drivers and axis controls to be tested.

2.3.1 ESP-RC02-I1 connections

The ESP-RC02-I1 test bench interface is supplied with four main connectors. The signals of some pins of these connectors can automatically switch according to the drivers or axis controls connected. Others four connectors are available on the side to connect analog signals.

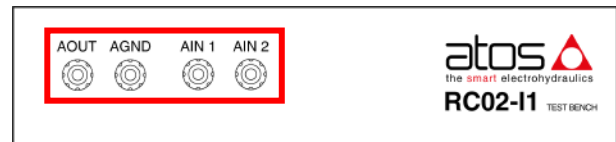
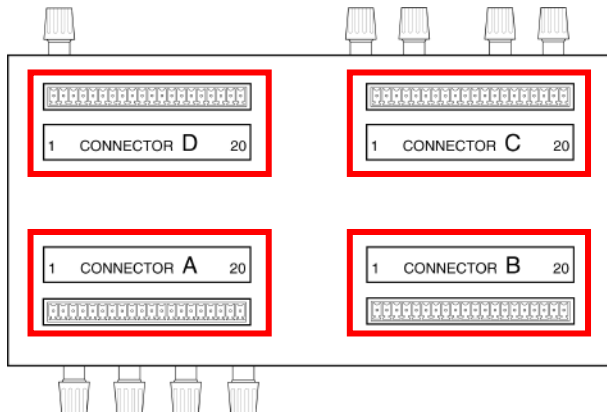

Connector A

PIN	SIGNAL	SIGNAL ALTERNATIVE 1	SIGNAL ALTERNATIVE 2
1	V+		
2	V0		AGND
3	VL+	DIN0	
4	VL0	DIN1	AGND
5	ENABLE	AGND	
6	FAULT		
7	REPEAT EN		
8	INPUT1+		
9	INPUT1-		
10	INPUT2+	AGND	
11	INPUT2-		
12	MONITOR 1	FAULT	
13	MONITOR 2	REPEAT EN	
14	DIN0		
15	DIN1		
16	FEED TR2+		
17	FEED TR3+		
18	PE		
19	DGND		
20	AGND		

Connector B

PIN	SIGNAL	SIGNAL ALTERNATIVE 1	SIGNAL ALTERNATIVE 2
1	FEED T		
2	+15VT		
3	-15VT		
4	+24VT		
5	FEED L		
6	+15VL		
7	-15VL		
8	+24VL		
9	FEED TR1+		
10	FEED TR1-		
11	FEED TR2+		
12	FEED TR2-		
13	FEED TR3+		
14	FEED TR3-		
15	+24VTR		
16	VREF+		
17	VREF-		
18	VSEL		
19	DGND		
20	AGND		

Connector C

PIN	SIGNAL	SIGNAL ALTERNATIVE 1	SIGNAL ALTERNATIVE 2
1	DATA+		
2	DATA-		
3	CLOCK+		
4	CLOCK-		
5	INPUT R		
6	INPUT /R		
7	INPUT A		
8	INPUT /A		
9	INPUT B		
10	INPUT /B		
11	VSEL		
12	AIN AUX 1		
13	AIN AUX 2		
14	OUT AN 1		
15	OUT AN 4		
16	TEST 3		
17	CTRL OUT +		
18	CTRL OUT -		
19	DGND		
20	AGND		

Connector D

PIN	SIGNAL	SIGNAL ALTERNATIVE 1	SIGNAL ALTERNATIVE 2
1	DI 1		
2	DI 2		
3	DI 3	VREF+	
4	DI 4	VREF-	
5	DI 5		
6	DI 6		
7	DI 7		
8	DI 8		
9	DO 1		
10	DO 2		
11	DO 3		
12	DO 4		
13	DO 5		
14	DO 6		
15	DO 7		
16	DO 8		
17	RAMP 0		
18	RAMP 0		
19	DGND		
20	AGND		

Analog connectors

The AOUI, AGND, AIN1, AIN2 analog connectors must be connected only with analog signals provided by drivers or axis controls connected.

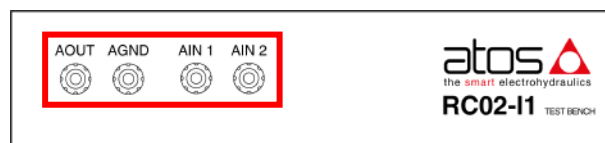

WARNING: connect only analog signals provided by drivers and axis controls (different analog signals connected could be damage the interface).

2.3.2 ESP-RC02-I2 connections

The ESP-RC02-I2 test bench interface is supplied with two cards holder, one undecal socket one connector and one terminal board. Others four connectors are available on the side to connect analog signals.

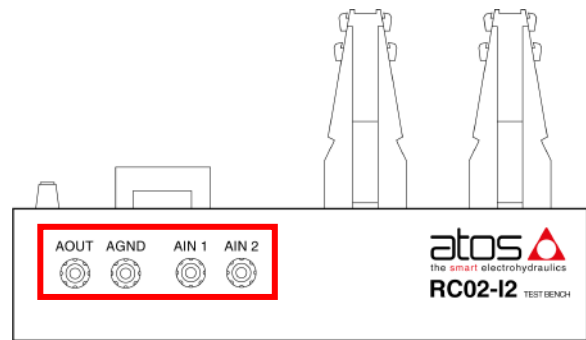
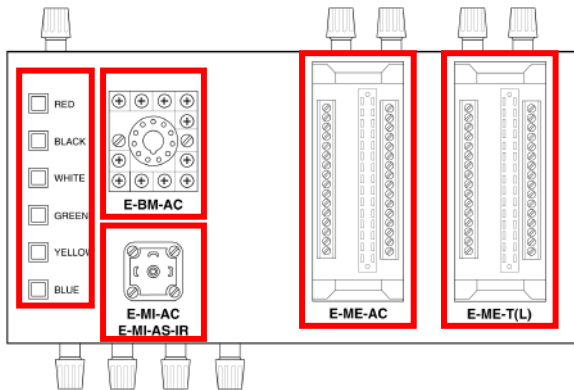

Card holder for E-ME-T

SIGNAL	PIN		SIGNAL
	c	a	
+ (24 V _{DC})	2	2	+ (24 V _{DC})
- (24 V _{DC})	4	4	- (24 V _{DC})
RAMP EXCLUSION	6	6	RAMP EXCLUSION
ENABLE (+ 24 V _{DC})	8	8	GND
+ 10 V _{DC} 10 mA	10	10	
REFERENCE +	12	12	- 15 V _{DC} 20 mA
- 10 V _{DC} 10 mA	14	14	+ 15 V _{DC} 50 mA
GND	16	16	GND
REFERENCE -	18	18	SPOOL FEEBACK
24 V _{DC}	20	20	24 V _{DC}
FAULT	22	22	
	24	24	
COIL S1	26	26	COIL S1
	28	28	
COIL S2	30	30	COIL S2
(E-ME-T-05H)	32	32	(E-ME-T-05H)

Card holder for E-ME-L

SIGNAL	PIN		SIGNAL
	c	a	
+ (24 V _{DC})	2	2	+ (24 V _{DC})
- (24 V _{DC})	4	4	- (24 V _{DC})
RAMP EXCLUSION	6	6	RAMP EXCLUSION
ENABLE	8	8	REFERENCE -
+ 10 V _{DC} 10 mA	10	10	
REFERENCE +	12	12	- 15 V _{DC} 20 mA
- 10 V _{DC} 10 mA	14	14	+ 15 V _{DC} 20 mA
GND	16	16	GND
IN E-TH-*	18	18	IN E-TH-*
24 V _{DC}	20	20	24 V _{DC}
AXIS READY	22	22	
	24	24	
COIL S1	26	26	COIL S1
	28	28	
	30	30	
	32	32	

Card holder for E-ME-AC

SIGNAL	PIN		SIGNAL
	c	a	
+ POWER SUPPLY	2	2	+ POWER SUPPLY
- POWER SUPPLY	4	4	- POWER SUPPLY
RAMP SW OFF	6	6	RAMP SW OFF
+ 15 V _{DC} 50 mA	8	8	GND
+ 5 V _{DC} 50 mA	10	10	
EXT REFERENCE IN	12	12	- 15 V _{DC} 20 mA
- 5 V _{DC} 20 mA	14	14	GND
	16	16	
REFERENCE INVERSION (+24 V _{DC}) (only for 05F)	18	18	ENABLE (+24 V _{DC})
REF. 1-2	20	20	REF. 4-3
REF. 1	22	22	REF. 4
REF. 2	24	24	REF. 3
COIL S1	26	26	COIL S1
	28	28	
COIL S2	30	30	COIL S2
(only for 05F)	32	32	(only for 05F)

Undecal socket for:

E-BM-AC-01F and E-BM-AC-011F

PIN	SIGNAL
1	- POWER GND
2	- INPUT SIGNAL R1 0 ÷ +5V
3	+ INPUT SIGNAL R1 0 ÷ +5V
4	COIL S2 (for 01F do not connect 4,5)
5	
6	+ 5V (10 mA)
7	+ INPUT SIGNAL R2 0 ÷ +5V (for 01F do not connect 7,8)
8	- INPUT SIGNAL R2 0 ÷ +5V (for 01F do not connect 7,8)
9	COIL S1
10	
11	+ POWER SUPPLY V+

Undecal socket for:

E-BM-AC-05F and E-BM-AC-01F/*B

PIN	SIGNAL
1	- POWER GND
2	- INPUT SIGNAL R1 ±5V
3	+ INPUT SIGNAL R1 ±5V
4	COIL S2 (for 01F/*B do not connect 4,5)
5	
6	+ 5V (10 mA)
7	- 5V (10 mA)
8	
9	COIL S1
10	
11	+ POWER SUPPLY V+

Coil connector and terminal board for E-MI-AC

Coil connector – for all versions

PIN	SIGNAL
1	COIL
2	
3	EARTH

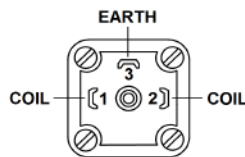

Terminal board – for standard execution

COLOUR		SIGNAL
TERMINAL BOARD	CABLE	
RED	RED	V+
BLACK	BLACK	V0
WHITE	WHITE	Current Input
GREEN	GREEN	Output 5VDC
YELLOW	YELLOW	Ref. Input +
BLUE	BLUE	Ref. Input -

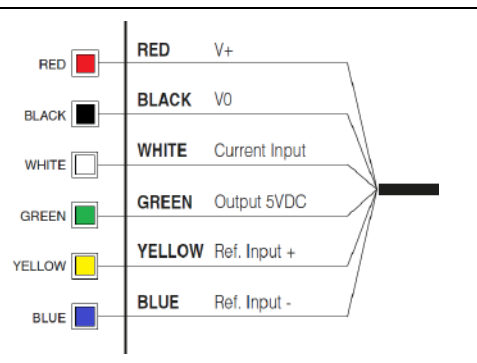

Terminal board – for /RR option

COLOUR		SIGNAL
TERMINAL BOARD	CABLE	
RED	RED	V+
BLACK	BLACK	V0
WHITE		
GREEN	GREEN	Output 5VDC
YELLOW	YELLOW	Ref. Input +
BLUE	BLUE	Ref. Input -
	WHITE	Current Input

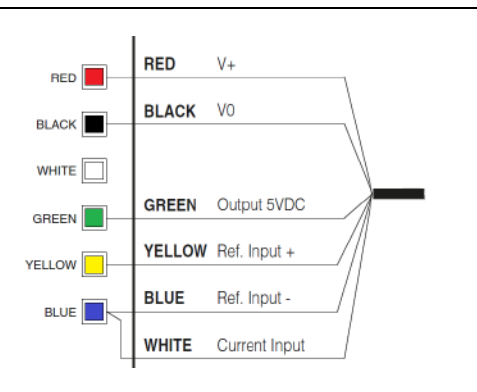

Coil connector and terminal board for E-MI-AS-IR

Coil connector – for all versions

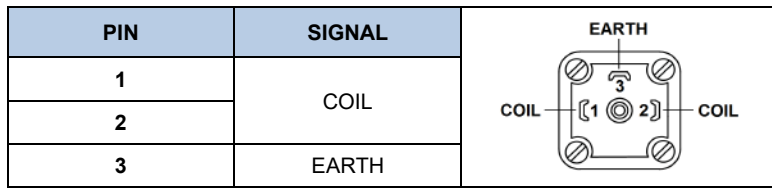

Terminal board – for standard execution

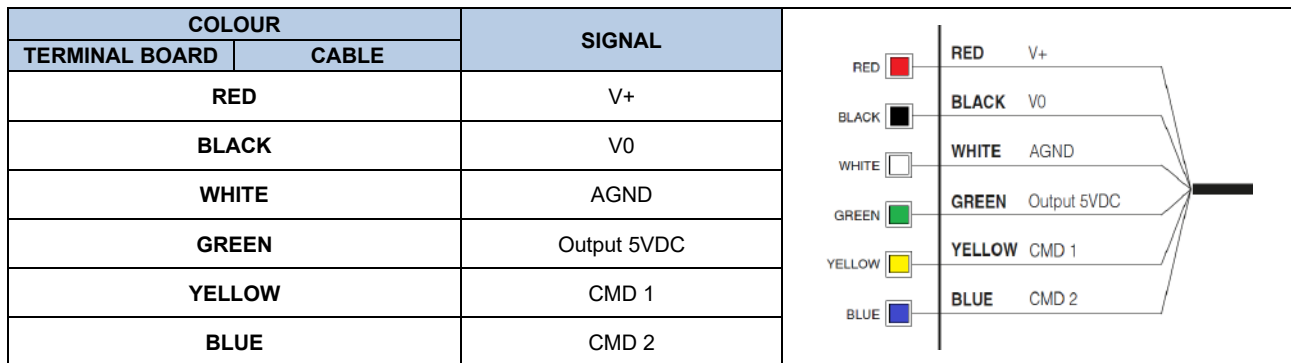

Terminal board – only for /M12 option

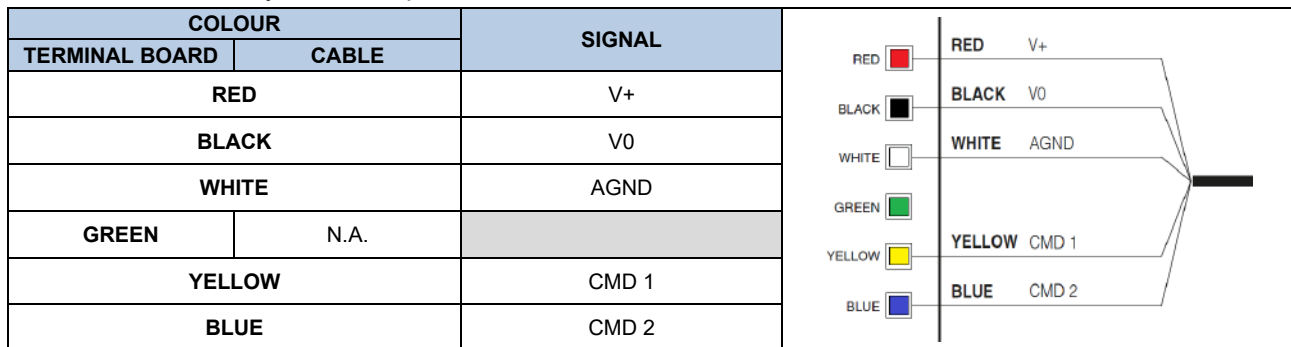

Analog connectors

The AOUT, AGND, AIN1, AIN2 analog connectors must be connected only with analog signals provided by drivers or axis controls connected.

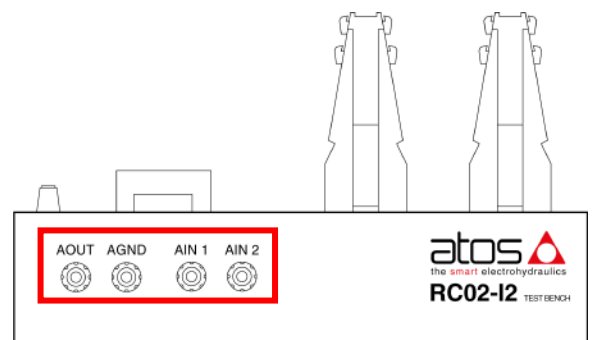

WARNING: connect only analog signals provided by drivers and axis controls (different analog signals connected could be damage the interface).

2.3.3 ESP-RC02-I3 connections

The ESP-RC02-I3 test bench interface is supplied with one undecal socket, one connector and one terminal board. Others two connectors are available on the side to connect analog signals.

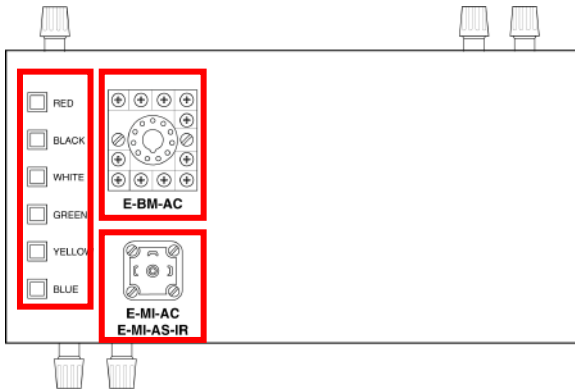

Undecal socket for:

E-BM-AC-01F and E-BM-AC-011F

PIN	SIGNAL
1	- POWER GND
2	- INPUT SIGNAL R1 0 ÷ +5V
3	+ INPUT SIGNAL R1 0 ÷ +5V
4	COIL S2 (for 01F do not connect 4,5)
5	
6	+ 5V (10 mA)
7	+ INPUT SIGNAL R2 0 ÷ +5V (for 01F do not connect 7,8)
8	- INPUT SIGNAL R2 0 ÷ +5V (for 01F do not connect 7,8)
9	COIL S1
10	
11	+ POWER SUPPLY V+

Undecal socket for:

E-BM-AC-05F and E-BM-AC-01F/*B

PIN	SIGNAL
1	- POWER GND
2	- INPUT SIGNAL R1 ±5V
3	+ INPUT SIGNAL R1 ±5V
4	COIL S2 (for 01F/*B do not connect 4,5)
5	
6	+ 5V (10 mA)
7	- 5V (10 mA)
8	
9	COIL S1
10	
11	+ POWER SUPPLY V+

Coil connector and terminal board for E-MI-AC

Coil connector – for all versions

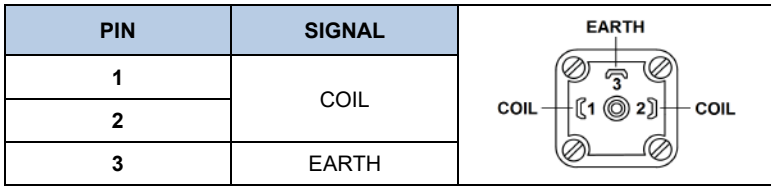

Terminal board – for standard execution

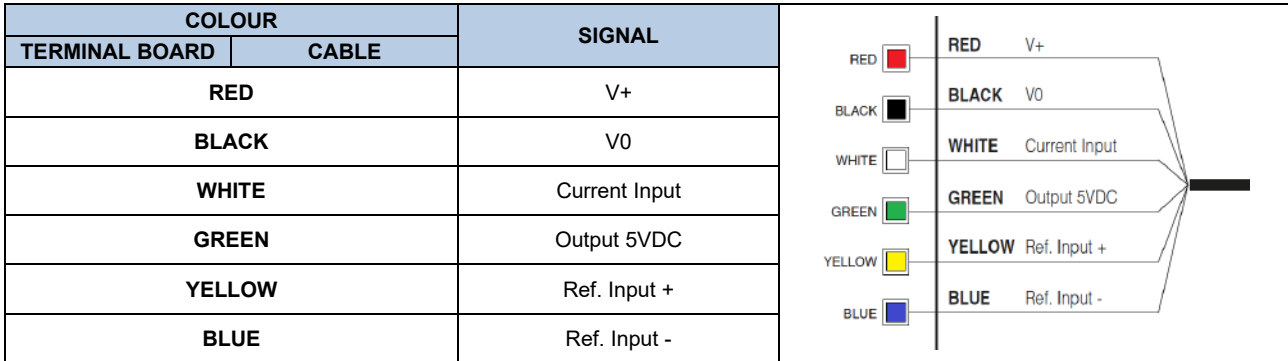

Terminal board – for /RR option

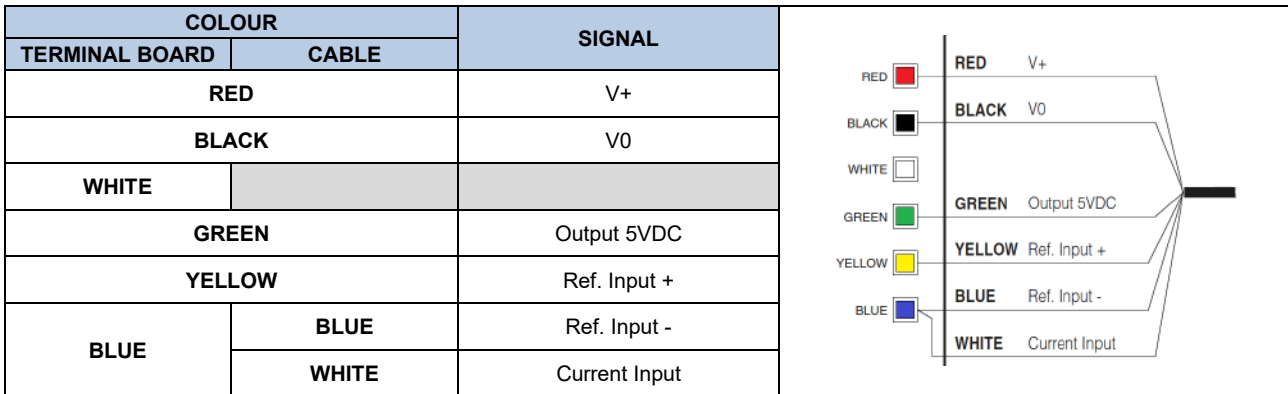

Coil connector and terminal board for E-MI-AS-IR

Coil connector – for all versions

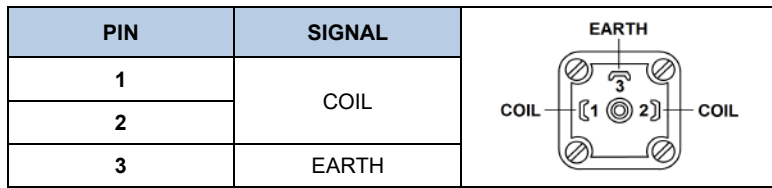

Terminal board – for standard execution

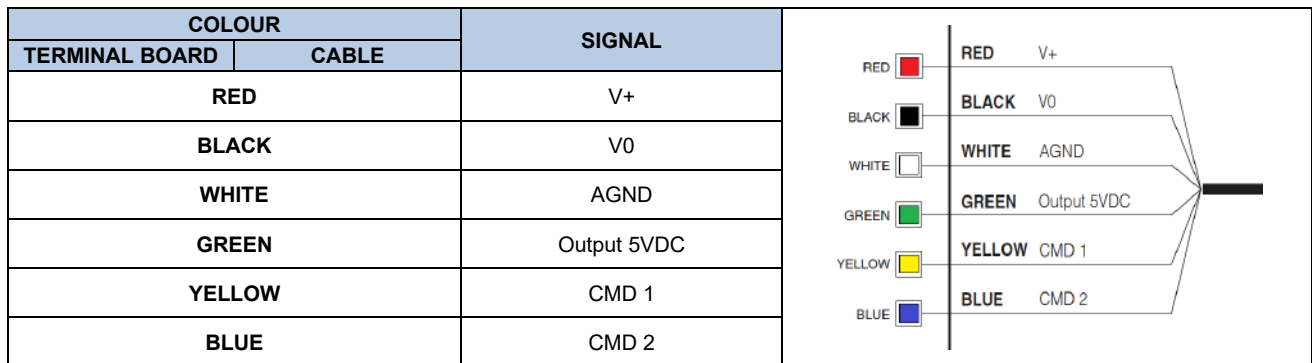

Terminal board – only for /M12 option

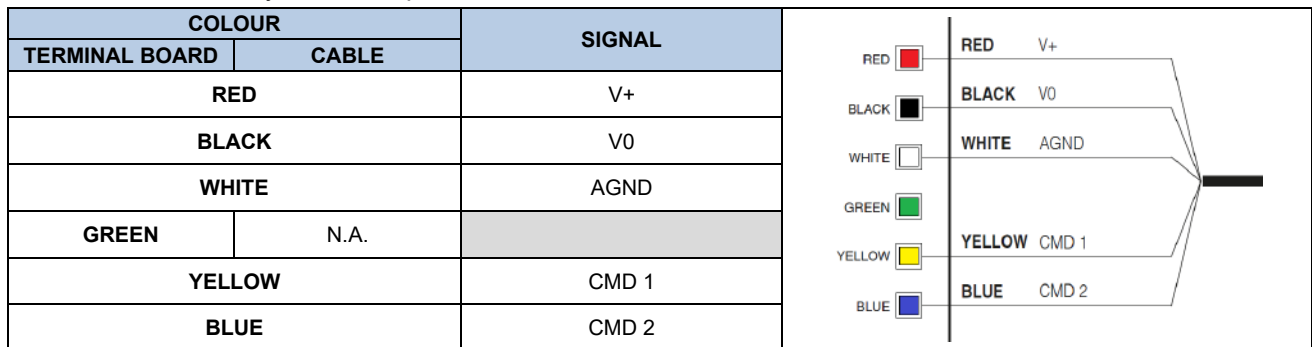

Analog connectors

The AIN1, AIN2 analog connectors must be connected only with analog signals provided by drivers or axis controls connected.

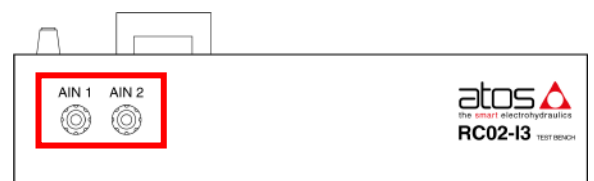

WARNING: connect only analog signals provided by drivers and axis controls (different analog signals connected could be damage the interface).

3 DRIVERS AND SOFTWARE INSTALLATION

Registration (only for first supply)

Register the Atos programming software on www.download.atos.com to obtain the password for the software activation; software starts and it works without activation code for 10 days from the installation date. After 10 days the software stops until the user inputs the activation code.

Once terminated the hardware installation (please refer also QS-RC02 Quickstart – see 1.2.1) install on PC the drivers and software.

- insert SW-KEY into the PC USB port
- open **Atos Software** directory

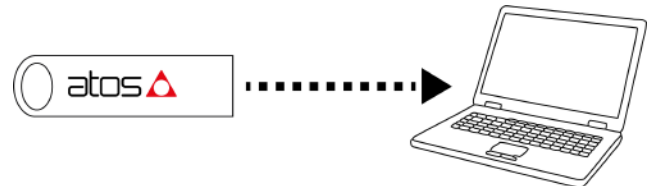

 **ATTENTION:** all drivers and software have to be correctly installed on PC before to start with the test procedure.

3.1.1 Drivers installation

- open **USB-IR** directory
 - click on *.**exe** to start driver installation
 - follow displayed instructions to complete the installation process
 - after installation open the **USB-M12** directory
- open **USB-M12** directory
 - click on *.**exe** to start driver installation
 - follow displayed instructions to complete the installation process
 - after installation open the **USB-SERIAL** directory
- open **USB-SERIAL** directory
 - click on *.**exe** to start driver installation
 - follow displayed instructions to complete the installation process
 - once terminated the drivers installation, go to 3.1.2

3.1.2 Software installation

 E-SW-FULL and Z-SW-FULL have to be installed before of AAT software.

 To install Atos software, the user must have administrator rights on the system.

- open **E-SW-FULL** directory
 - click on **setup.exe** to start driver installation
 - follow displayed instructions to complete the
 - installation process
 - after installation open the **Z-SW-FULL** directory

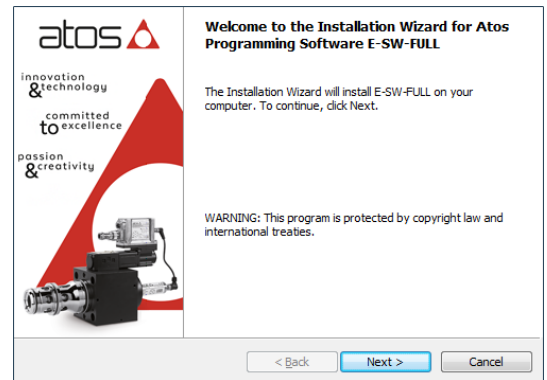

- open **Z-SW-FULL** directory
 - click on **setup.exe** to start driver installation
 - follow displayed instructions to complete the
 - installation process
 - after installation open the **AtosAutoTest** directory



- open **AtosAutoTest** directory
 - click on **setup.exe** to start driver installation
 - follow displayed instructions to complete the
 - installation process

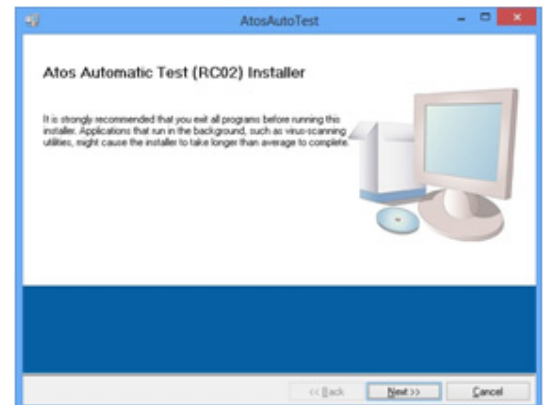

4 ABOUT E-SW AND Z-SW SOFTWARE

E-SW-FULL and Z-SW-FULL software allow to verify, modify and store/restore the drivers/axis controls parameters. The software can work directly with the parameters of a connected driver (ON-LINE) or with parameters stored in the PC (OFF-LINE). The 'Main window' of the software, displayed at start-up, allows to handle all basic settings and diagnostic operations on the driver/axis control.

4.1 Main window

The 'Main window' is divided in three areas:

- Communication Area
- Valve, Driver, Axis control Signals Area
- Multifunction Area

The 'Main window' allows to completely operate Atos valves/drivers/axis controls by:

- simply access and numerically set all the functional parameters
- verify the actual working conditions
- identify and quickly solve fault conditions
- adapt the factory parameters to the application requirements
- store the customized setting into the valve
- archive the customized setting into the PC

Main Window Structure

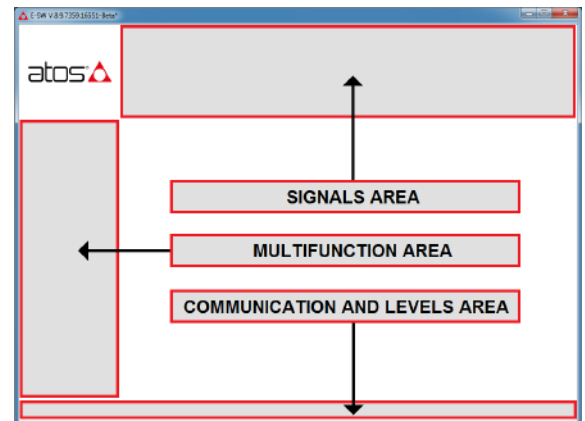

 The window's graphic interface is automatically adapted at start-up of the software according to the connected valve/driver/axis control and to the selected access level.

 For E-SW-FULL and Z-SW-FULL set the access level on: "**Level 7 - Service**"

In the 'Main window' are always available the following information and commands:

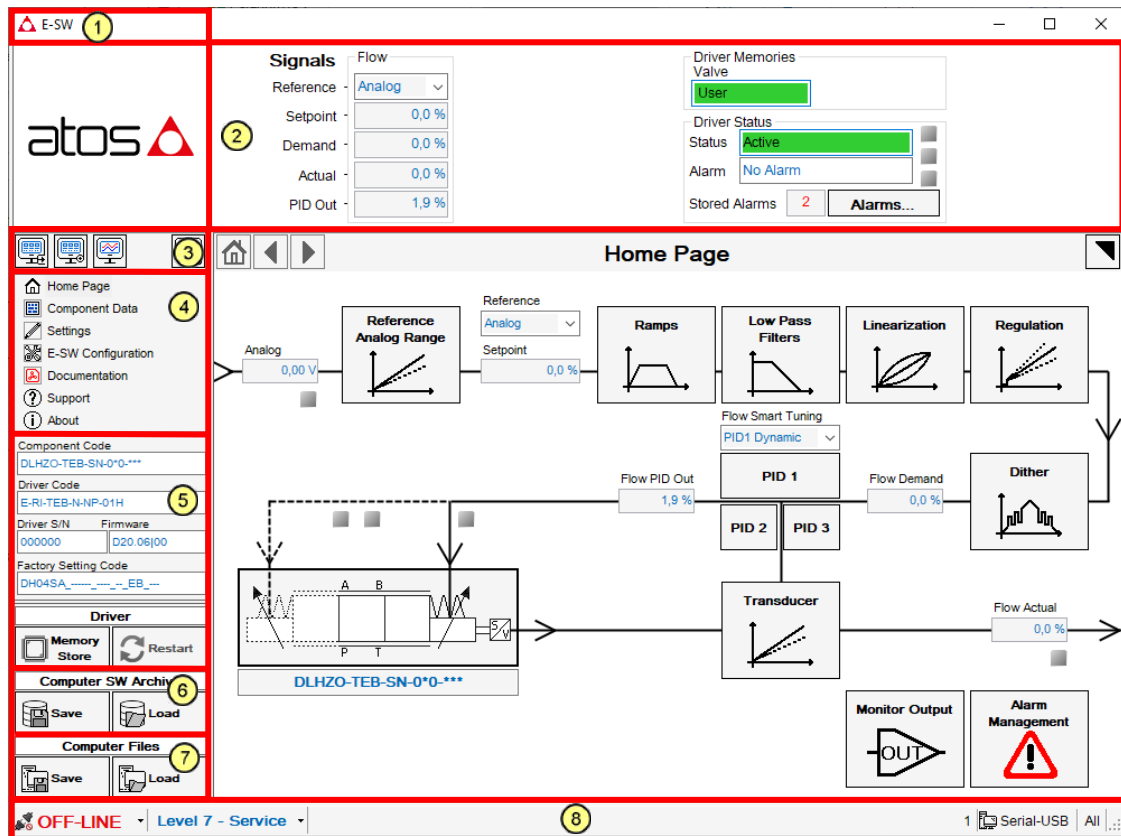

The image is intended for explanatory purposes only and may show differences in accordance to the connected electronics.

- ① software type and version
- ② Valve/Driver/Axis control signals area
- ③ commands to open windows of: 'Valve/Driver/Axis control Signals', 'Valve/Driver/Axis control Signals – Extended page' and 'Oscilloscope'
- ④ menu settings
- ⑤ Valve/Driver/Axis control characteristics connected
- ⑥ commands to open 'Valve/Driver/Axis control - Memory Store' window or to restart the driver/axis control
- ⑦ commands to access to 'Setting Files Archive' software page
- ⑧ communication and actual level area

4.1.1 Parameters issue



The Atos software implements parameters alarm detection system in order to identify missing parameters or eventual communication errors.

4.1.2 Missing parameters (OFF-LINE)

The indicator  shows specific colour for missing parameter value, if selected settings file is incomplete or corrupted.



 Write the missing value into the indicator  and save the 'Setting File' on the PC hard disk.

 The symbol  is displayed aside missing parameters.

 If a 'Setting File' with missing parameter is downloaded into the driver/axis control, the missing parameters will overwrite by default values present into the driver/axis control.

4.1.3 Communication errors (ON-LINE)

The indicator  shows specific colour for communication errors.



 Check the communication parameters.

4.2 Communication area

In the bottom area of the Main window, it is possible to verify and change the status of communication between software (E-SW or Z-SW) and devices connected (drivers or axis controls).

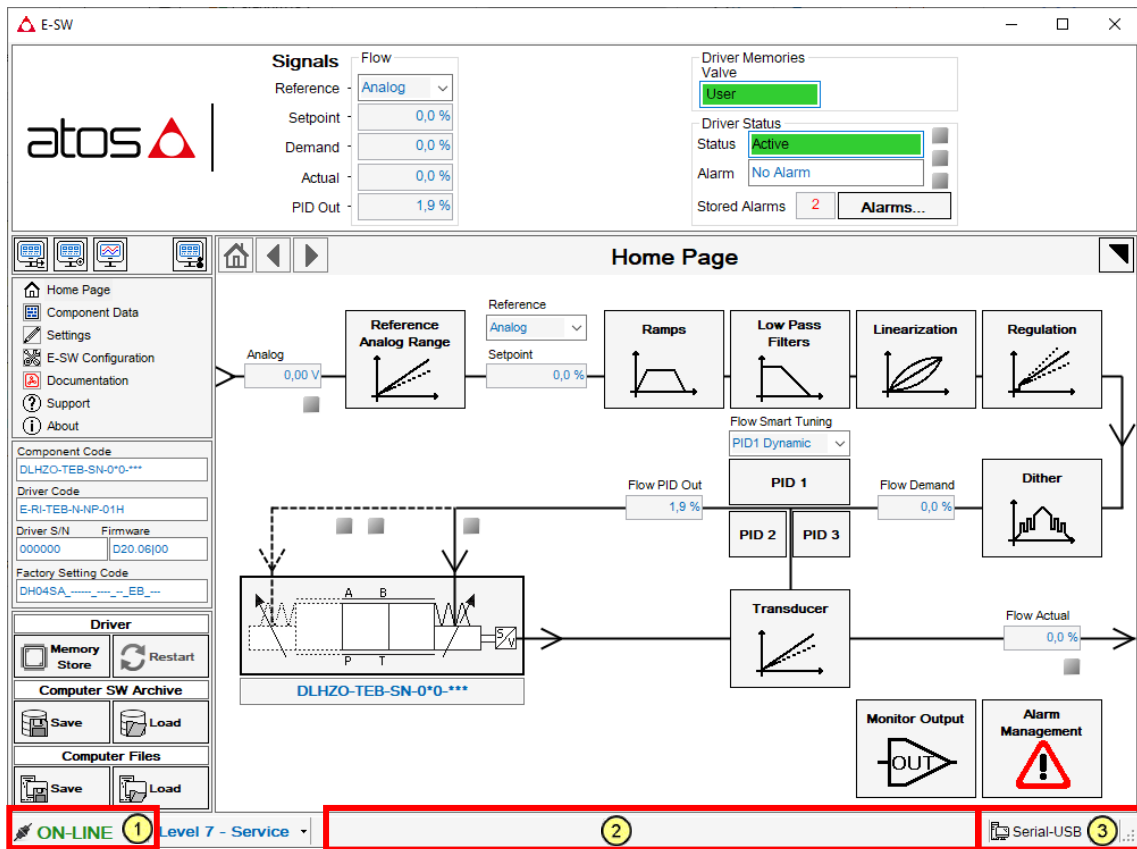

4.2.1 ON-LINE and OFF-LINE status

The indicator ① allows the user to verify the actual status of the communication between the E-SW or Z-SW software and the connected driver/axis control.



To change status between **ON-LINE** and **OFF-LINE** (or vice versa) click on black arrow: the selection menu opens (see image at side).

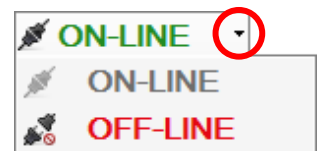

(communication active)

“Actual Parameters” of both software and driver are linked (every change in the software is applied in the driver/axis control and vice versa)
In this status the **OFF-LINE** button allows to disconnect the driver or axis control from E-SW or Z-SW and to pass in **OFF-LINE**



At start-up the E-SW or Z-SW software always tries to pass in ON-LINE mode if a valve/driver/axis control is properly connected.



Always use this communication mode to completely operate and verify the connected driver/axis control.



(communication not active)

“Actual Parameters” of the software are not linked to the driver/axis control (they can be changed but are not applied to the driver/axis control)
In this status the **ON-LINE** button allows to connect the driver/axis control to E-SW or Z-SW and to pass in **ON-LINE**



Switching from **OFF-LINE** to **ON-LINE** a message will ask which parameters must be maintained: the software or driver/axis control parameters value.



Press '**Download**' button to download parameters currently shown by software graphic interface into the driver/axis control, passing in **ON-LINE**.

Press '**Upload**' button to upload the driver/axis control actual parameters into the software graphic interface, passing in **ON-LINE**.



ON-LINE, **OFF-LINE** and **Download** buttons can be used to copy the same parameters into multiple driver, for example:

- Connect the driver to be copied and start the E-SW or Z-SW software (ON-LINE is automatically achieved)
- Press OFF-LINE button and connect communication cable to the second driver/axis control
- Press ON-LINE and select Download button

4.2.2 Communication Error

The indicator  allows the user to verify possible error in the communication with the valve/driver/axis control.



Only the last communication is displayed, double-click on the indicator  to view the list of all occurred messages.

4.2.3 Communication Settings Window

Double-click on indicator  to open the 'Communication' window and set the communication parameters of the E-SW or Z-SW programming software (OFF-LINE).

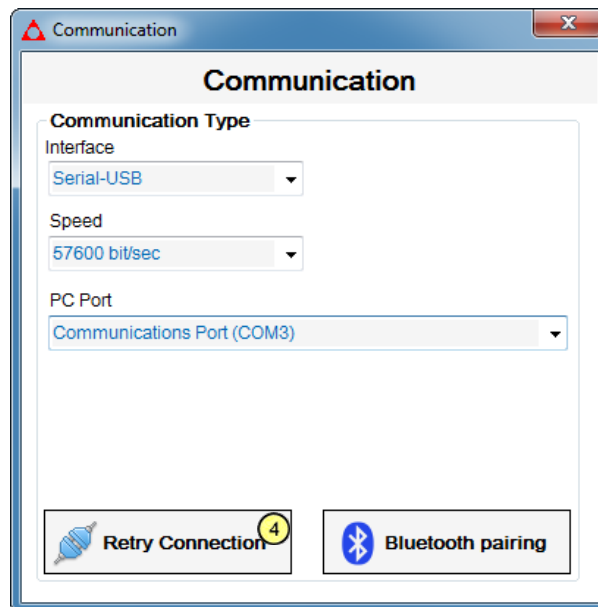

If button  is not displayed, press  for exit or confirm settings.



The commands not described are the same available for the 'Communication'.



For further information about E-SW and Z-SW, please refer the relevant programming manual.

4.3 Multifunction area [Computer SW Archive]

Multifunction area of the Main Window is organized in different section: press the “Save” or “Load” button in area ① to operate with the parameters ‘Setting Files’ saved into the PC hard-disk.



Save actual parameters (see 4.3.1)

Load setting file (see 4.3.2)

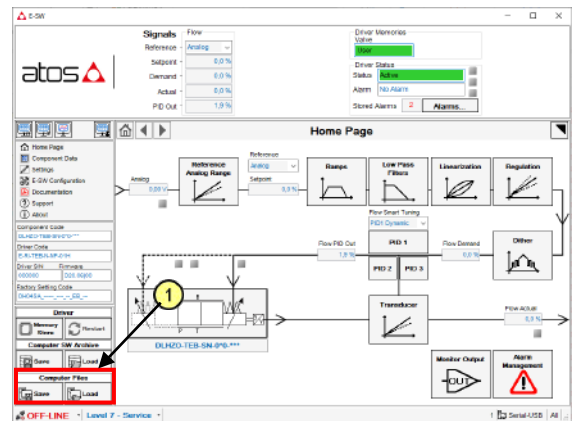

In ‘Computer SW Archive – Setting Files’ software page are available three different database:

User Archive

Press button to open the user setting database: this archive is used to save the setting files customized by the user.



Atos Archive

Press button to open the standard product archive: this archive is used to load the factory setting files included in the software installation, for standard series products.

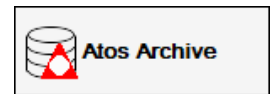

Atos Old Series Archive

Press button to open the old series product archive: this archive is used to load the factory setting files included in the software installation, for old series product.

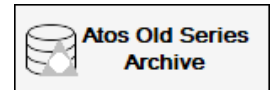

The setting file can be used efficiently as a starting point for executing repetitive installations of the same driver. For specific ‘Setting Files’ please contact the Technical Sales Support of Atos Electronic Division – ele-support@atos.com.

4.3.1 Save (store into pc)

This operation allows to save the “Actual Parameters” of the programming software into PC hard-disk as a ‘Setting File’.

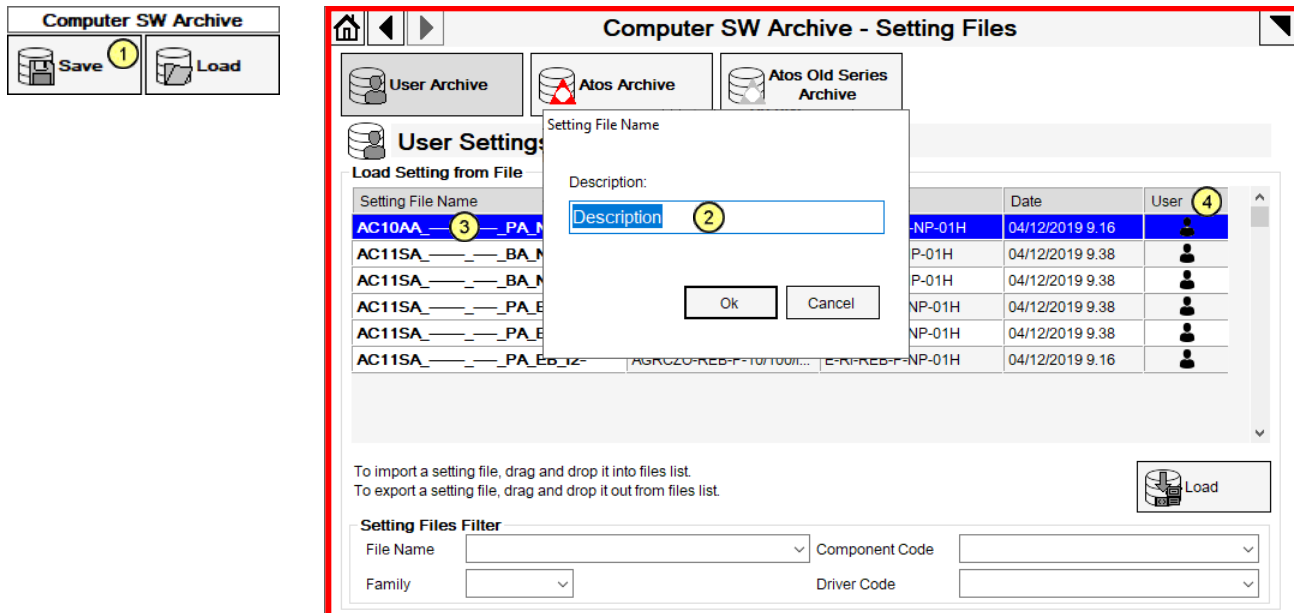

⚠ ATTENTION: only for digital drivers and axis controls the test procedure erases all setting parameters!



Before to start the test procedure, it is recommended save the user parameters.

- Click-on **Save** button (1) in multifunction area
- Insert a description (2) that will identify the new saved ‘Setting File’
- (e.g. “driver/axis control serial number_customer name”)
- click-on **Ok** button

💡 ‘Setting Files’ are only saved in ‘User Archive’.

💡 The new ‘Setting File’ will be displayed in (3): the available settings list for load operations.

💡 When in ON-LINE status (see 4.2.1), this operation allows to directly save “Actual Parameters” of the connected driver/axis control.

💡 User indication (4) allows to identify setting files delivered by Atos  and by the user .

5 ABOUT ATOS AUTOMATIC TEST SOFTWARE

Atos Automatic Test (AAT) software allow to testing all drivers/axis controls connected to the RC02 testing bench.

5.1 Main window

In the 'Main window' are always available the following information and commands:

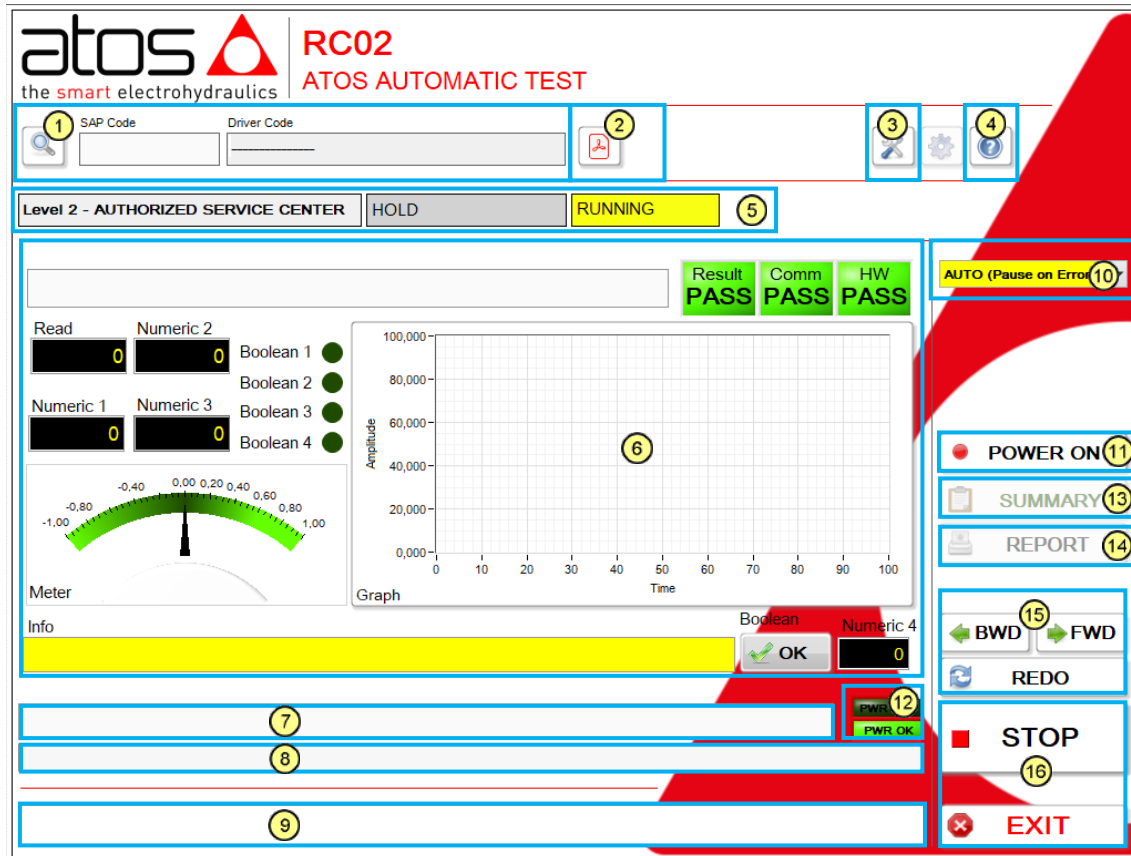

- ① Button to search SAP Code and Driver/Axis control Code information (see 5.4.1)
- ② Button to open documentation (see 5.4.2)
- ③ Button to open configuration software page (see 5.2)
- ④ Button to open user manual E-MAN-AAT
- ⑤ Actual level (5.3.4) and test sequence information (see 5.4.4)
- ⑥ Test information area
- ⑦ RC02 hardware info
- ⑧ Progress bar
- ⑨ Test result and program messages (see 5.4.10)
- ⑩ Test mode selection (see 5.4.3)
- ⑪ Button to switch on/off the power supply channels
- ⑫ Power supply information
- ⑬ Test Summary (see 5.4.11)
- ⑭ Report (see 5.4.12)
- ⑮ Control buttons (see 5.4.8)
- ⑯ Start (see 5.4.4), Stop (see 5.4.8) and Exit test buttons

5.2 Configuration window

In the 'Configuration window' are always available the following settings and commands:

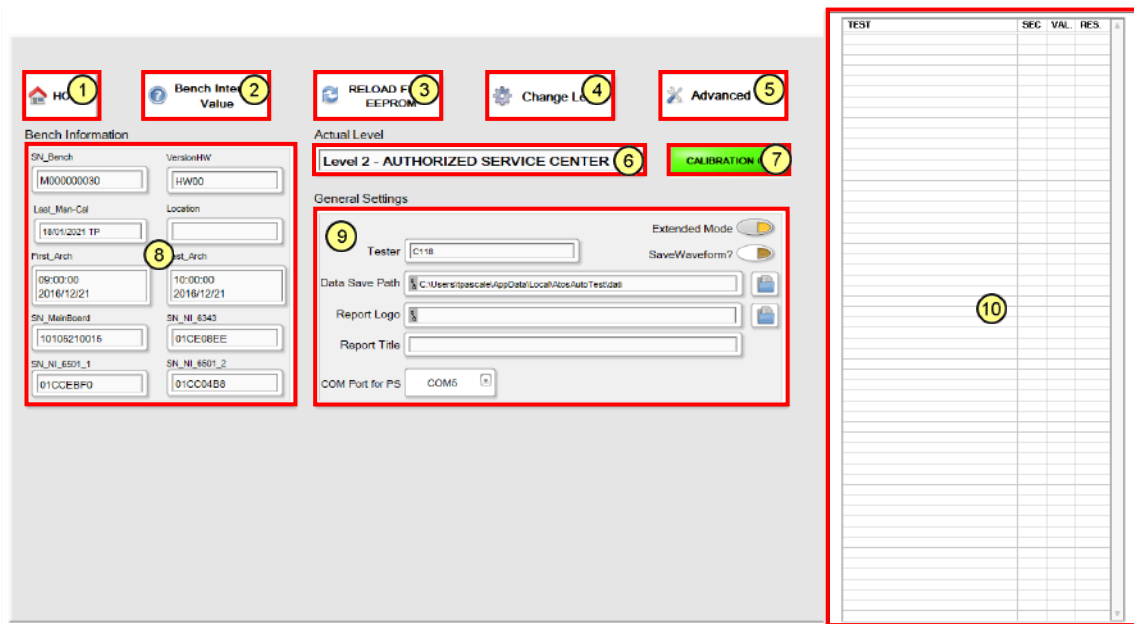

- ① Button to return to the main window (see 5.1)
- ② This button opens a window where are showed all internal voltage and temperature of the RC02
- ③ Press button to reload all 'Bench Information' data from internal EEPROM of the RC02
 - ⚠ The reload procedure takes several minutes. Use this function only if strictly necessary.
- ④ Press button to change the actual level (see 5.3.4)
- ⑤ 'Advanced Cfg' button functionality is available only for Atos
- ⑥ This indicator displays the actual level selected (see 5.3.4)
- ⑦ This indicator displays if calibration function is enabled (CALIBRATION ON) or disabled (CALIBRATION OFF) during the test procedure
- ⑧ RC02 test bench information area
- ⑨ RC02 test bench general settings area:

Tester: this control is used to insert the tester name (see 5.3.4)

Save Waveform?: this button allows to enable or disable the saving of graphs (Waveform) acquired during the test procedure

⚠ Saving the graphs significantly increases the size of the test summary file.

Data Save Path: this control allows to select the directory where to save the results of test procedure and configuration setting of the RC02

Extended Mode: this button allows to enable or disable the window ⑩, where are displayed the test sequence and the status of any single step

5.3 AAT– First Startup

5.3.1 Launch the software

1. Launch the AAT software using the proper icon on PC (desktop).

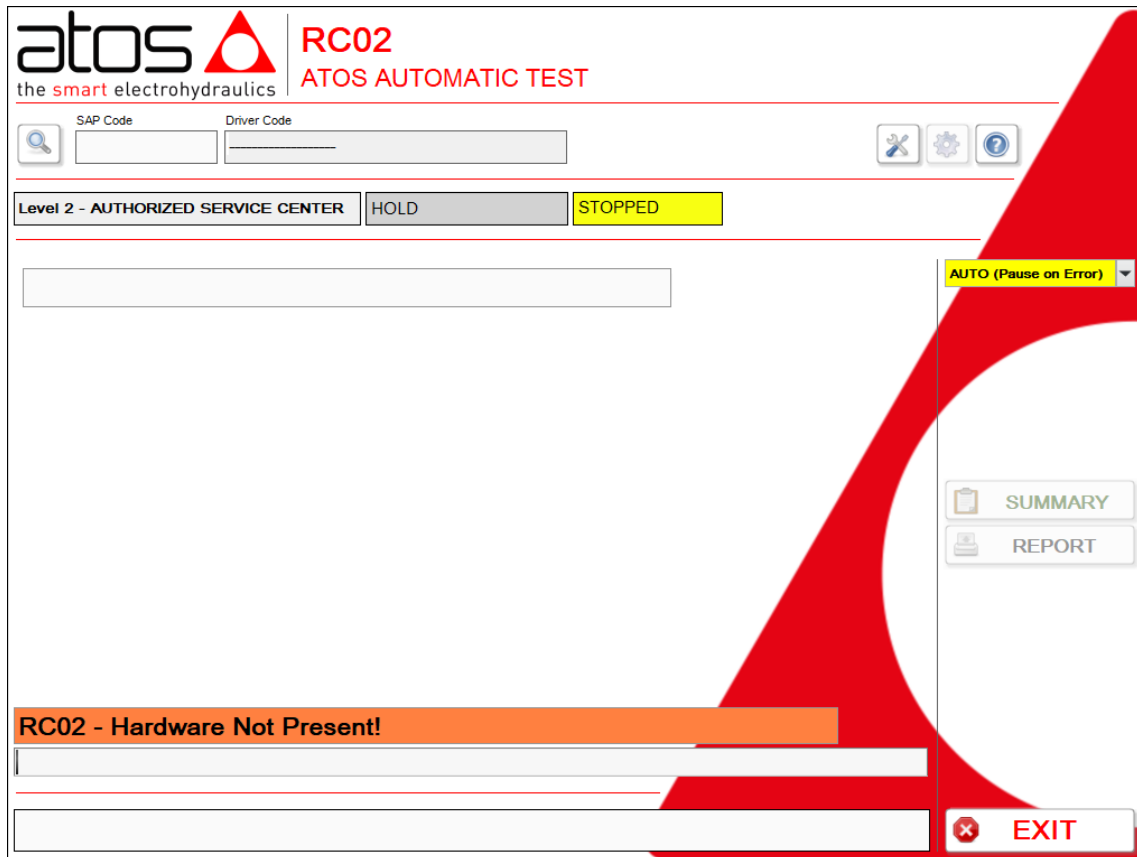

2. Set voltage and eventually replace the fuse for **ESP-RC02-P** (see 2.2)
3. Switch on the **ESP-RC02-P** - Programmable DC power supply (see 2.1)
4. Switch on the **ESP-RC02-M** - Main test bench (see 2.1)

 If appears the image below, select **Prevent all notification** (first run only).



5.3.2 Configuration Successfully

The system is configured automatically on the very first run. Press **OK** button.

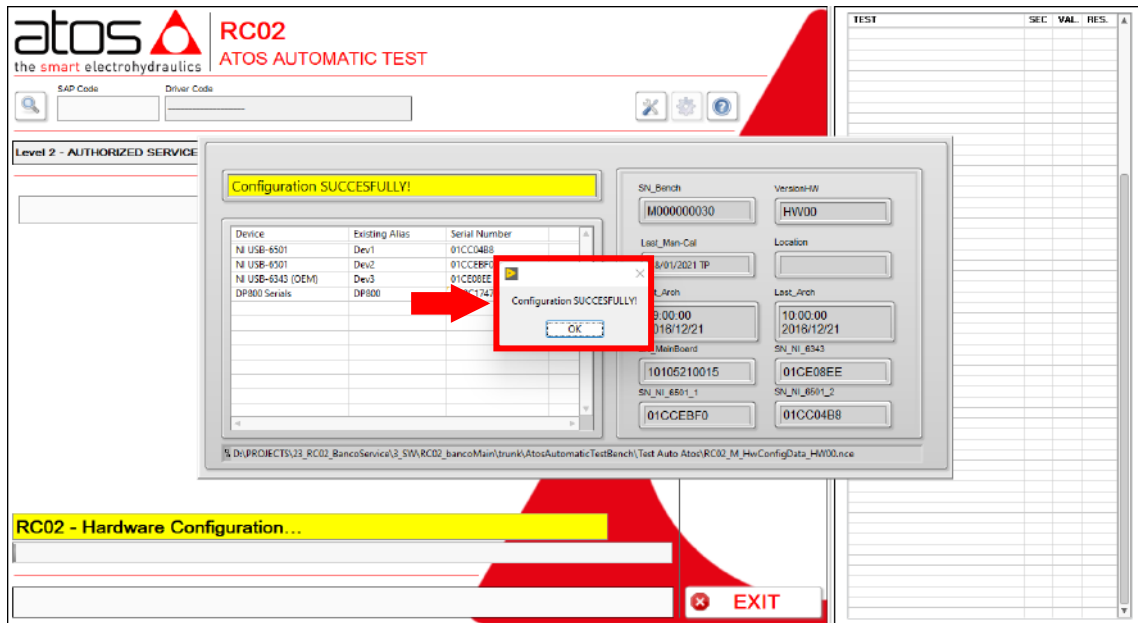

In case of 'Configuration Failed' switch off the ESP-RC02-M and repeat the procedure starting from 5.3.1. If the configuration is failed again, please contact the Atos technical support service.

5.3.3 RC02 - Hardware OK

The software has detected an hardware. Press **Config** button.

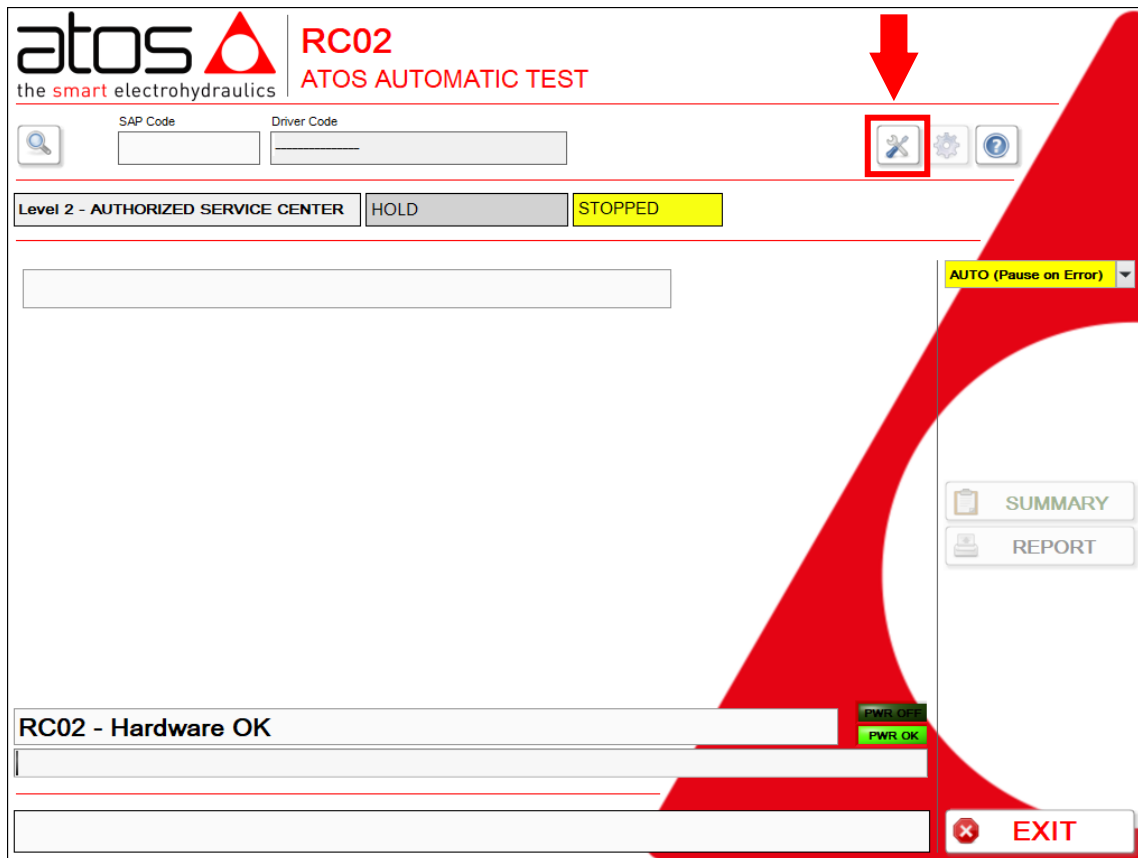

5.3.4 Configurations

1. Press **Change Level** button.

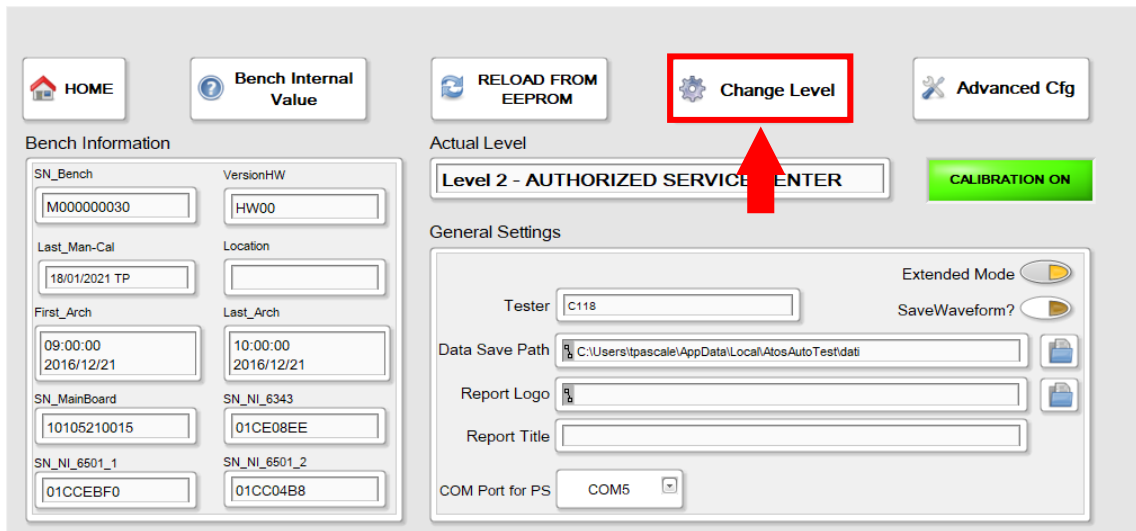

2. Insert access password **service** and press **OK** button.

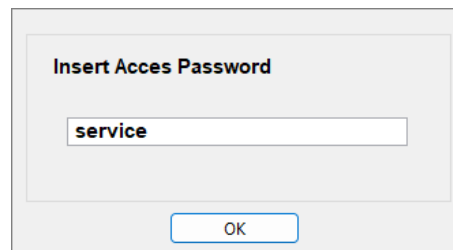

3. Only for drivers in **PS** execution (serial RS232), press **COM** button and select the serial COM port.

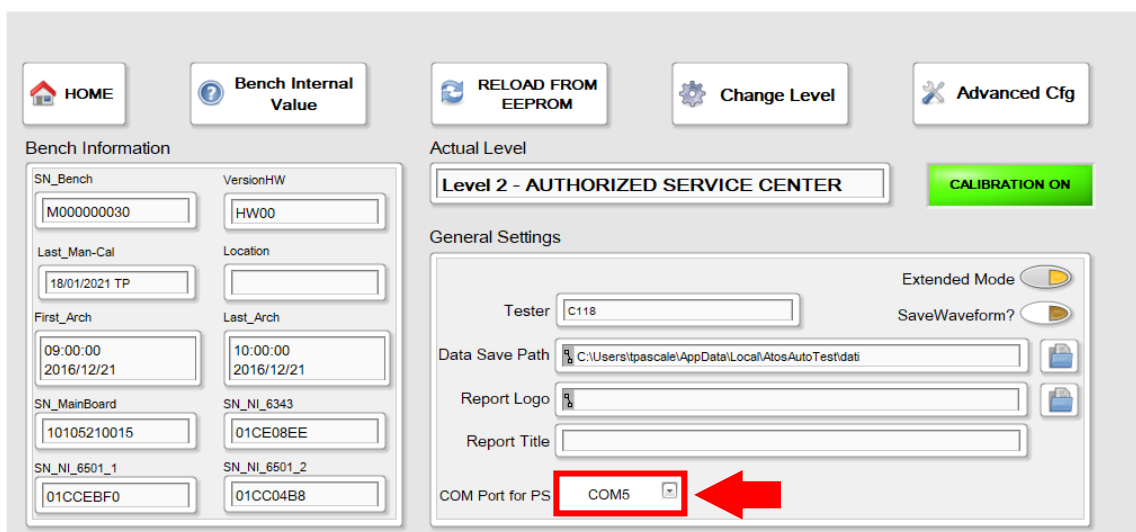

4. Insert the logo image or a title:

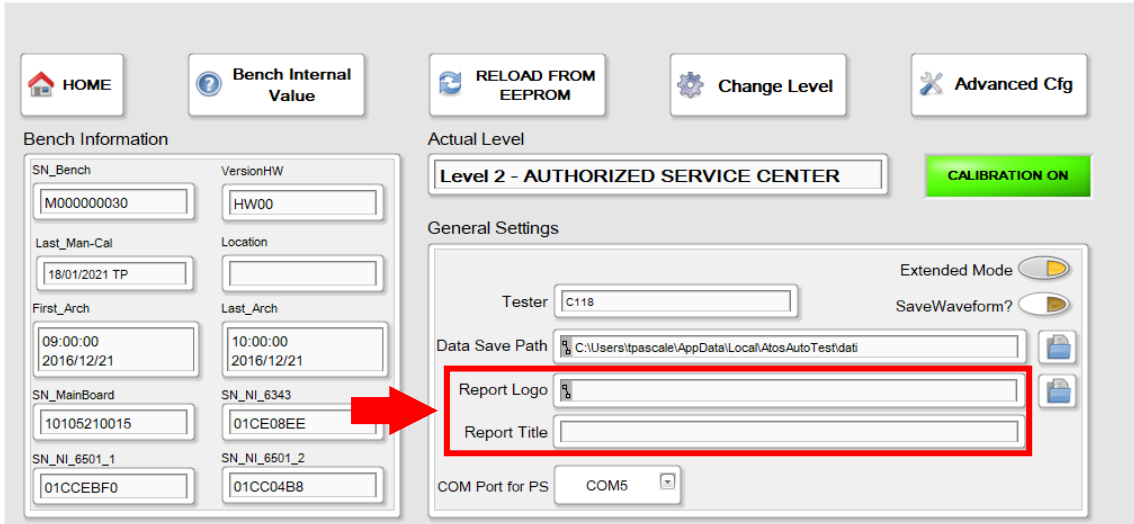

The screenshot shows the software interface with the following sections:

- Navigation:** HOME, Bench Internal Value, RELOAD FROM EEPROM, Change Level, Advanced Cfg.
- Bench Information:**
 - SN_Bench: M000000030
 - VersionHW: HW00
 - Last_Man-Cal: 18/01/2021 TP
 - Location:
 - First_Arch: 09:00:00 2016/12/21
 - Last_Arch: 10:00:00 2016/12/21
 - SN_MainBoard: 10105210015
 - SN_NI_6343: 01CE08EE
 - SN_NI_6501_1: 01CC04B8
 - SN_NI_6501_2: 01CC04B8
- Actual Level:** Level 2 - AUTHORIZED SERVICE CENTER (CALIBRATION ON)
- General Settings:**
 - Tester: C118
 - Extended Mode:
 - SaveWaveform?:
 - Data Save Path: C:\Users\tpascale\AppData\Local\AtosAutoTest\data
 - Report Logo: (highlighted with a red box)
 - Report Title:
 - COM Port for PS: COM5

- **Report Logo:** this function allows to upload the image of your company logo
- **Report Title:** as an alternative to the company logo it is possible to insert a text



Report Logo or Report Title will be show on the Report document (see 5.4.12).



Report Logo is priority. If both fields are filled (Report Logo and Report Title), only Report Logo will be show on the Report document (see 5.4.12).

5. Insert the tester name and press ENTER on PC.

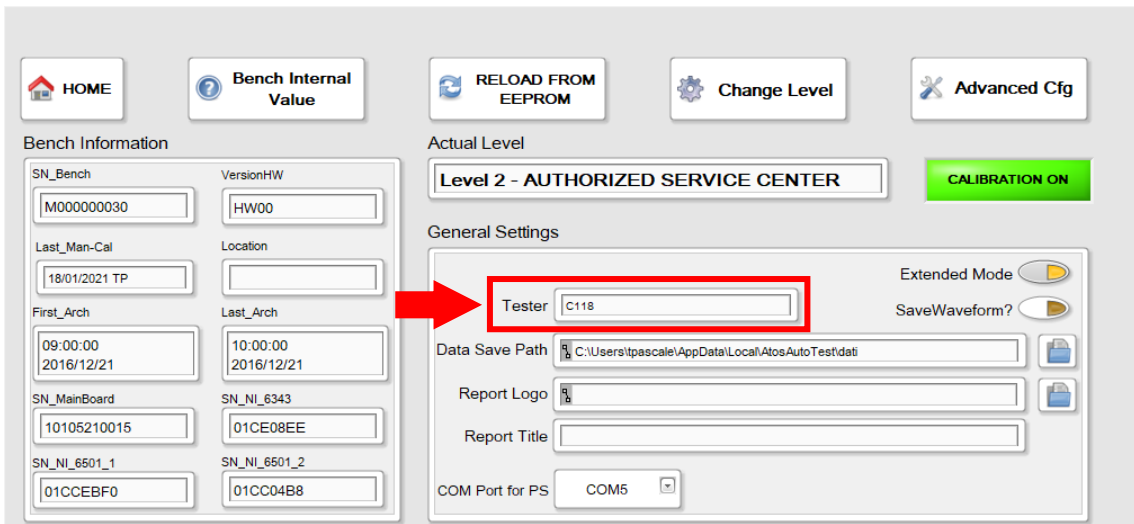

The screenshot shows the software interface with the following sections:

- Navigation:** HOME, Bench Internal Value, RELOAD FROM EEPROM, Change Level, Advanced Cfg.
- Bench Information:** (Same as in the previous screenshot)
- Actual Level:** Level 2 - AUTHORIZED SERVICE CENTER (CALIBRATION ON)
- General Settings:**
 - Tester: C118 (highlighted with a red box)
 - Extended Mode:
 - SaveWaveform?:
 - Data Save Path: C:\Users\tpascale\AppData\Local\AtosAutoTest\data
 - Report Logo:
 - Report Title:
 - COM Port for PS: COM5

6. Press **HOME** button to return on main window.

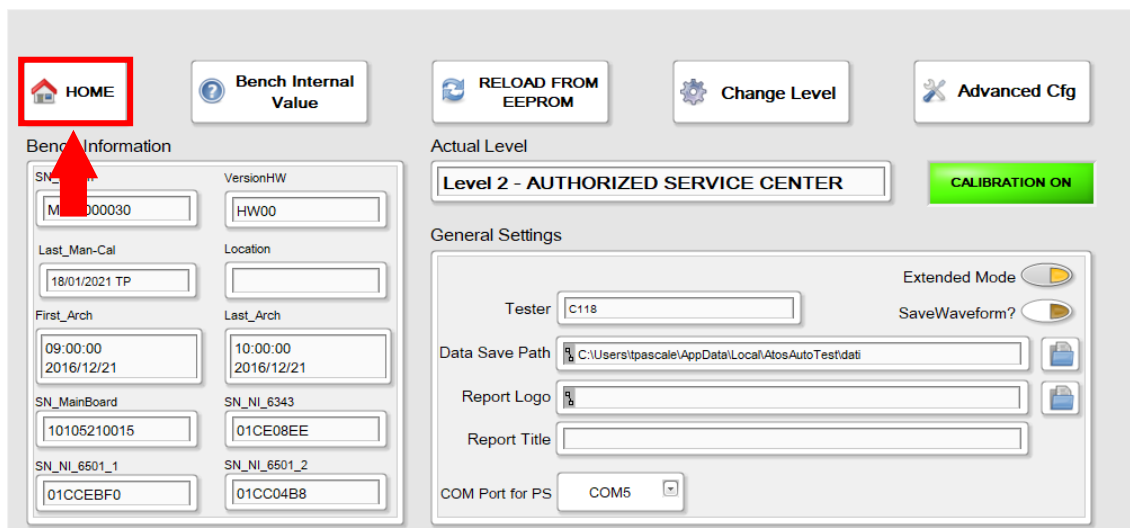

5.4 Test Execution

⚠ ATTENTION: only for digital drivers and axis controls the test procedure erases all setting parameters! Before to start the test procedure, it is recommended save the user parameters (see 4.3.1).

💡 Remember: once that the test procedure is terminated, reload the setting files (see 6).

5.4.1 Coding

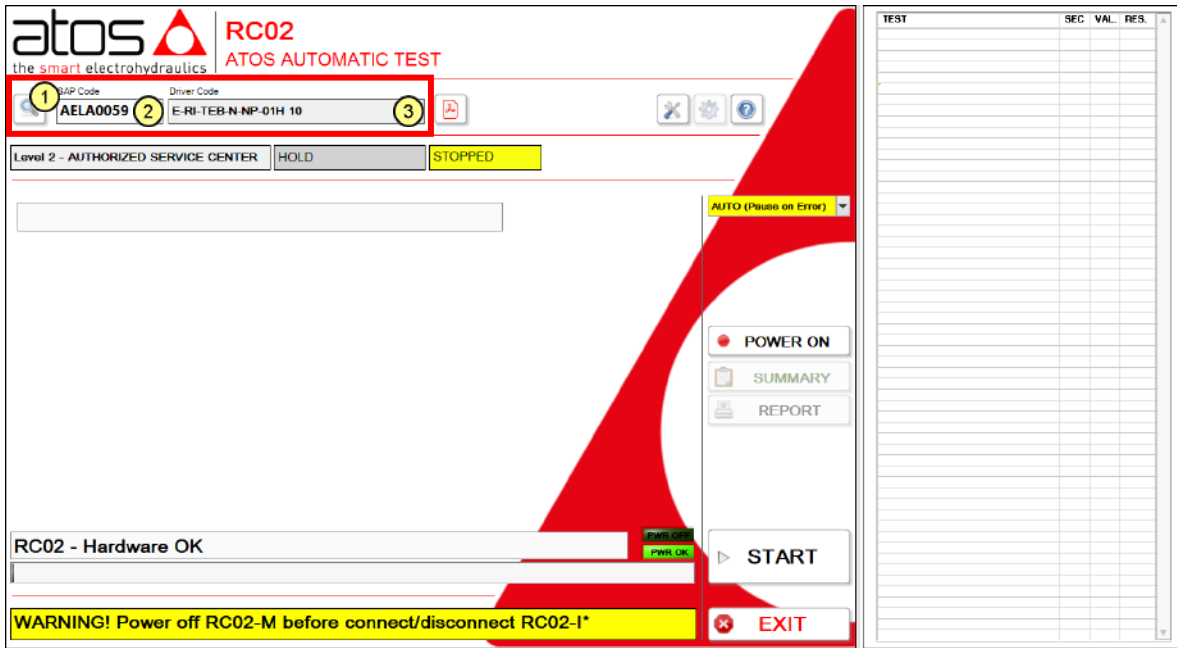

Press button ① if the SAP code is not known and the window to the side opens. Enter the complete driver/axis control model code with series and press ENTER on PC or button **Search**.

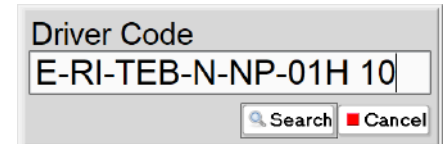

The indicator ② display the SAP code of the driver or axis control.

The indicator ③ display the driver or axis control code type.

5.4.2 Documentation

Before start the test procedure open the documentation to connect the driver or axis control to be tested.

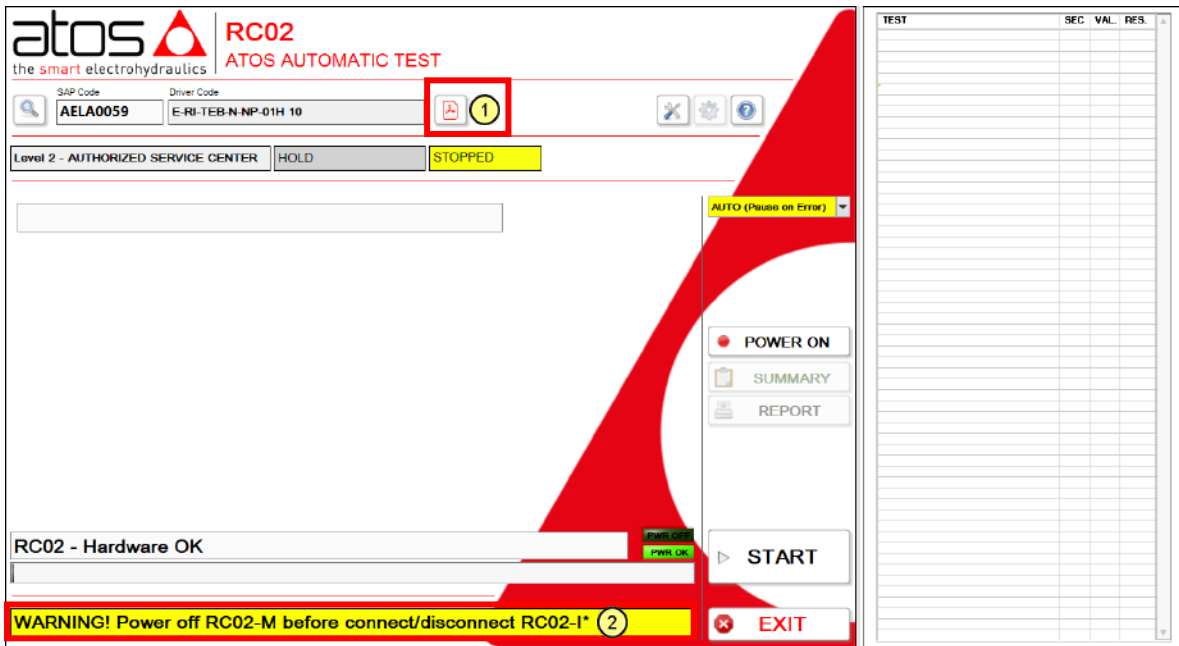

Press button ① to open the documentation related to the driver or axis control and following the instructions.

 The software automatically provide the correct documentation according to the SAP code (or model code) previously selected.

 Warning ②: the ESP-RC02-M must be SWITCHED-OFF before to connect or disconnect the interface test bench ESP-RC02-I*.

5.4.3 Test mode selection

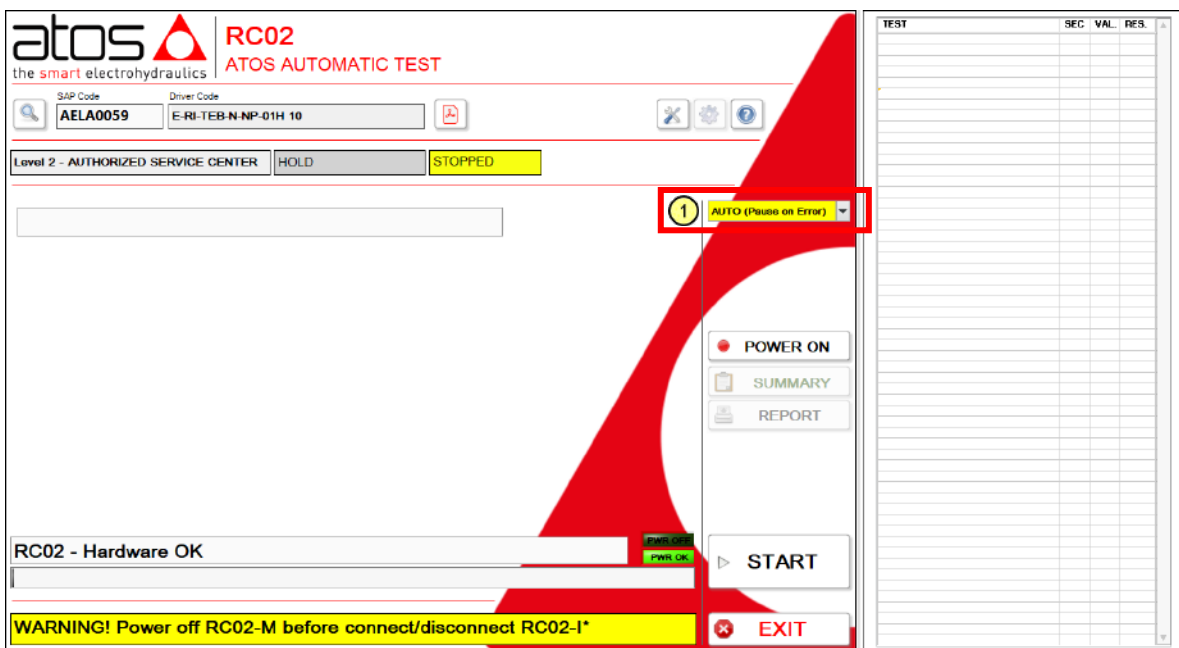

Press control ① to select test modality (see 5.4.8): AUTO (Pause on Error), AUTO (End on Error), STEP by STEP

5.4.4 Test sequence information

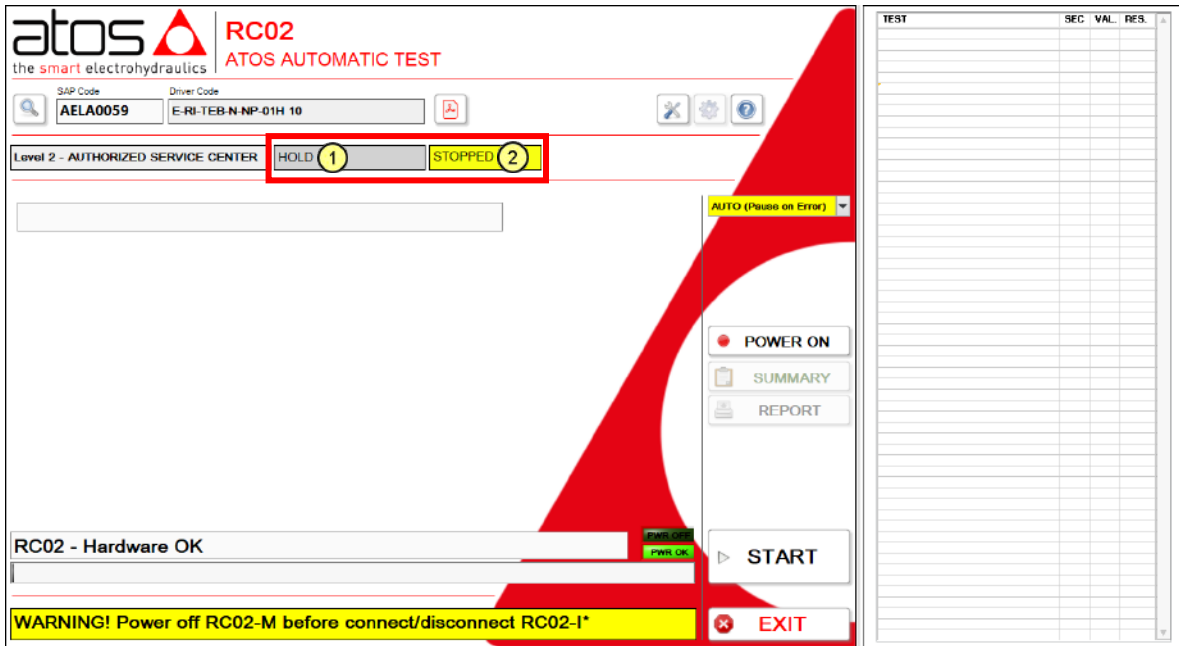

The indicator ② display communication status between digital drivers and axis controls to PC.

The indicator ③ display the internal status of the software.

5.4.5 Start test

1. Check all connections and if they are OK press button ① to start the test procedure.

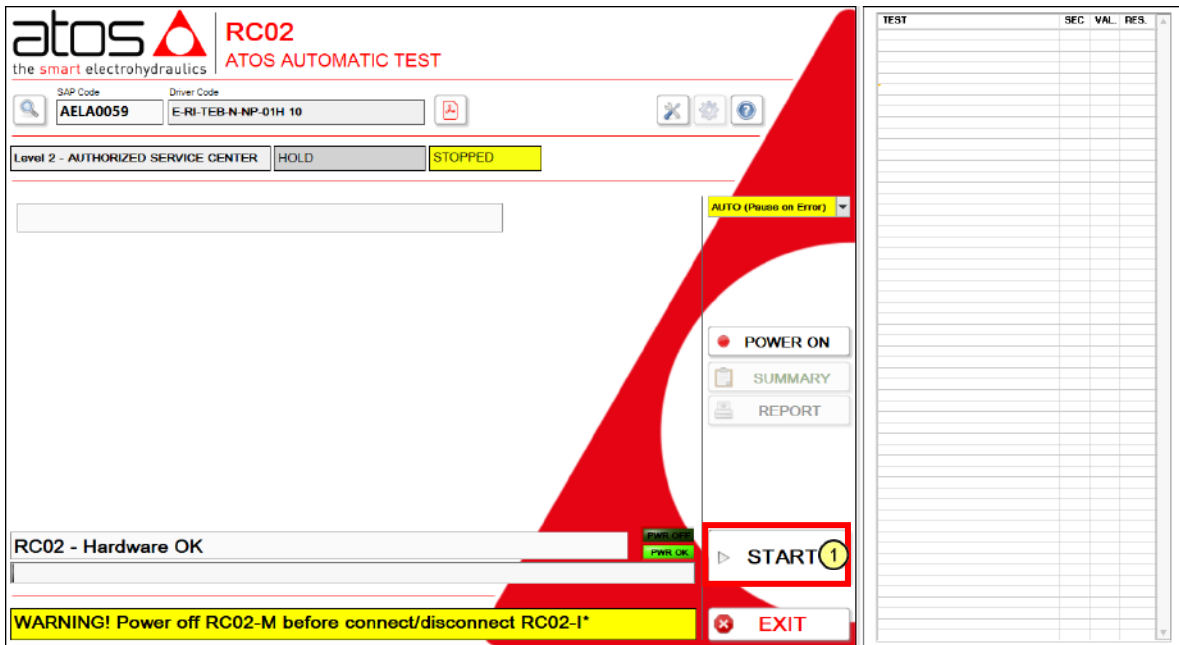

5.4.7 Manual setup – during the automatic test procedure

Example: BIAS S1 CALIBRATION (for this test the operator is need)

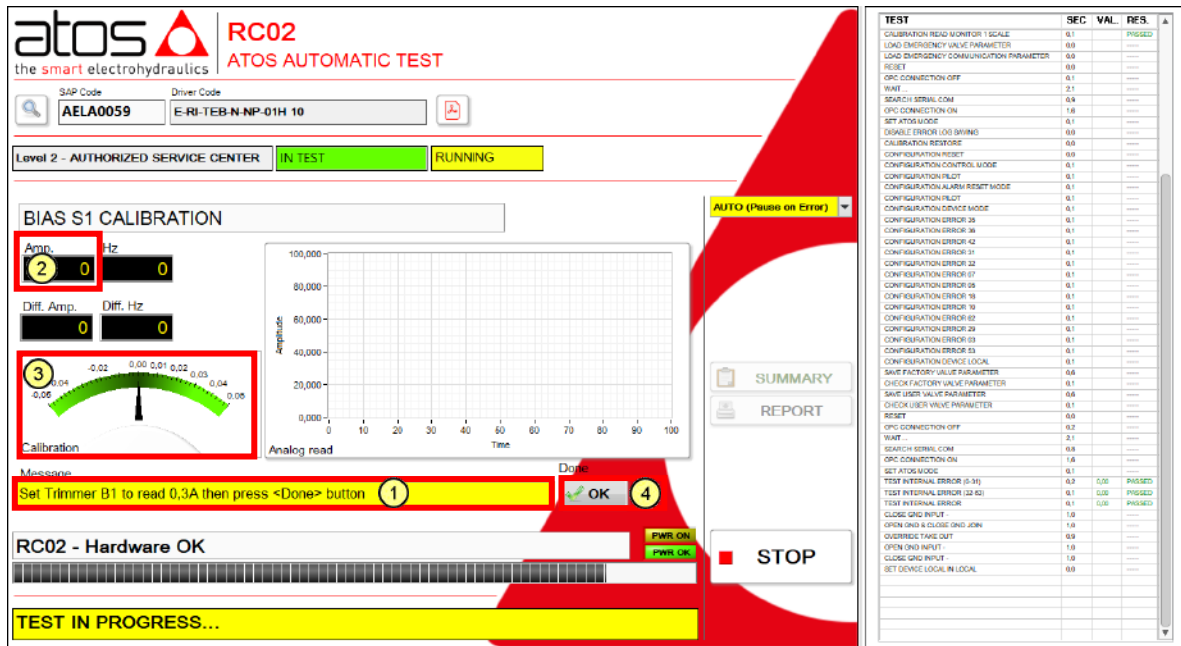

TEST	SEC	VAL	RES
CALIBRATION READ MONITOR 1 SCALE	0,1		PIGGED
LOAD EMERGENCY VALVE PARAMETER	0,0		
LOAD EMERGENCY COMMUNICATION PARAMETER	0,0		
RESET	0,0		
ORC CONNECTION OFF	0,1		
WAIT	2,1		
SEARCH SERIAL COM	0,0		
ORC CONNECTION ON	1,0		
SET ATOS MODE	0,1		
DISABLE ERROR LOG SHIMS	0,0		
CALIBRATION RESTORE	0,0		
CONFIGURATION CONTROL LOGGE	0,1		
CONFIGURATION PILOT	0,1		
CONFIGURATION ALARM RESET MODE	0,1		
CONFIGURATION PILOT	0,1		
CONFIGURATION DEVICE MODE	0,1		
CONFIGURATION ERROR 30	0,1		
CONFIGURATION ERROR 36	0,1		
CONFIGURATION ERROR 42	0,1		
CONFIGURATION ERROR 31	0,1		
CONFIGURATION ERROR 32	0,1		
CONFIGURATION ERROR 37	0,1		
CONFIGURATION ERROR 25	0,1		
CONFIGURATION ERROR 18	0,1		
CONFIGURATION ERROR 19	0,1		
CONFIGURATION ERROR 02	0,1		
CONFIGURATION ERROR 29	0,1		
CONFIGURATION ERROR 03	0,1		
CONFIGURATION ERROR 03	0,1		
CONFIGURATION ERROR 03	0,1		
CONFIGURATION DEVICE LOCAL	0,1		
SAVE FACTORY VALVE PARAMETER	0,0		
CHECK FACTORY VALVE PARAMETER	0,1		
SAVE USER VALVE PARAMETER	0,0		
ORION USER VALVE PARAMETER	0,1		
RESET	0,0		
ORC CONNECTION OFF	0,2		
WAIT	2,1		
SEARCH SERIAL COM	0,0		
ORC CONNECTION ON	1,0		
SET ATOS MODE	0,1		
TEST INTERNAL ERROR (5 31)	0,2	0,00	PIGGED
TEST INTERNAL ERROR (12 03)	0,1	0,00	PIGGED
TEST INTERNAL ERROR	0,1	0,00	PIGGED
CLOSE GND INPUT	1,0		
ORION GND & CLOSE GND JOIN	1,0		
OVERRIDE FAULT OUT	0,0		
ORION GND INPUT	1,0		
CLOSE GND INPUT	1,0		
SET DEVICE LOCAL IN LOCAL	0,0		

1. Follow the instruction showed in the control ① (e.g. Set Trimmer B1 to read 0,3A then press 'Done' button)

2. Through the trimmer B1 set the value to 0,3A (read the main value in the indicator ②)



The value displayed in the indicator ② can oscillate quickly and read it can be result difficult; to obtain a more accurate setting, see in the meter ③ the arrow position that must be result near to the center.

3. When the calibration is done, press button ④

5.4.8 Pause or Pause on Error

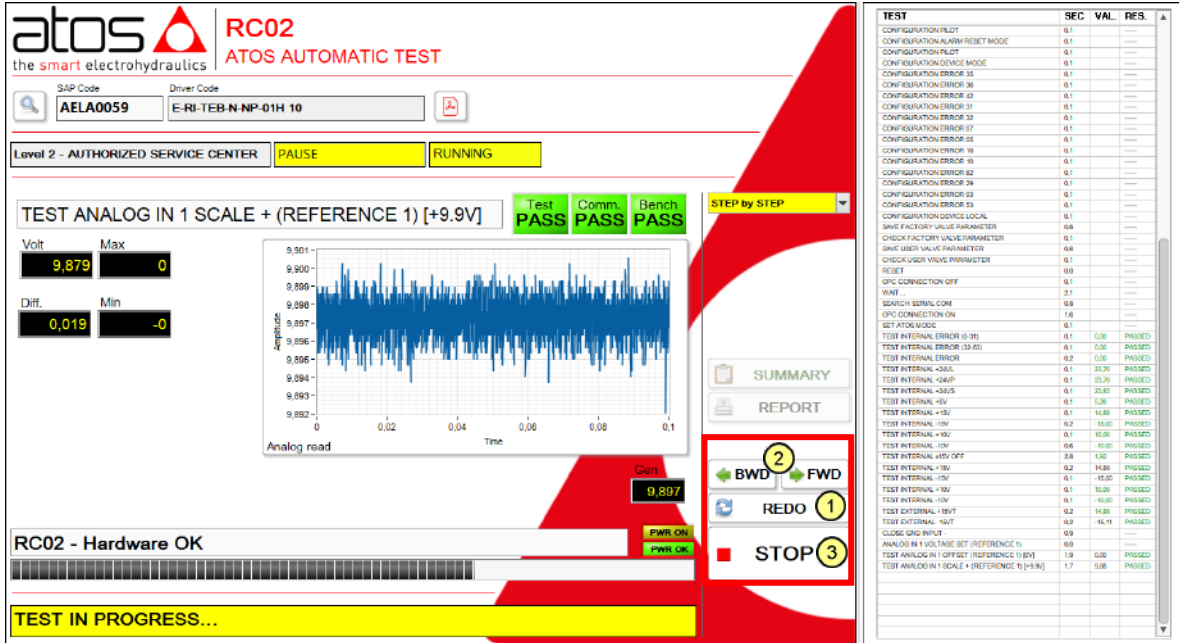

The screenshot displays the ATOS AUTOMATIC TEST software interface. The top left shows the ATOS logo and the text "the smart electrohydraulics". The main title is "RC02 ATOS AUTOMATIC TEST". Below this, there are fields for "SAP Code" (AELA0059) and "Driver Code" (E-RI-TEB-N-NP-01H 10). The interface is divided into several sections:

- Level 2 - AUTHORIZED SERVICE CENTER:** Includes "PAUSE" and "RUNNING" buttons.
- TEST ANALOG IN 1 SCALE + (REFERENCE 1) [+9.9V]:** Shows "Test PASS", "Comm PASS", and "Bench PASS" indicators. A graph displays "Analog read" vs "Time" with a value of 9.879 and a difference of 0.019.
- RC02 - Hardware OK:** Shows "PWR OK" and "PWR OK" indicators.
- TEST IN PROGRESS...:** A yellow banner at the bottom.
- Control Panel:** Includes "BWD" (2), "FWD", "REDO" (1), and "STOP" (3) buttons.
- TEST LOG Table:** A table on the right side of the interface listing test steps, their duration (SEC), and results (RES).

TEST	SEC	VAL	RES
CONFIGURATION PILOT	0.1	---	---
CONFIGURATION ALARM RESET MODE	0.1	---	---
CONFIGURATION PILOT	0.1	---	---
CONFIGURATION DEVICE MODE	0.1	---	---
CONFIGURATION ERROR 35	0.1	---	---
CONFIGURATION ERROR 36	0.1	---	---
CONFIGURATION ERROR 42	0.1	---	---
CONFIGURATION ERROR 31	0.1	---	---
CONFIGURATION ERROR 32	0.1	---	---
CONFIGURATION ERROR 37	0.1	---	---
CONFIGURATION ERROR 35	0.1	---	---
CONFIGURATION ERROR 36	0.1	---	---
CONFIGURATION ERROR 39	0.1	---	---
CONFIGURATION ERROR 42	0.1	---	---
CONFIGURATION ERROR 39	0.1	---	---
CONFIGURATION ERROR 33	0.1	---	---
CONFIGURATION ERROR 33	0.1	---	---
CONFIGURATION DEVICE LOCAL	0.1	---	---
SAVE FACTORY VALUE PARAMETER	0.0	---	---
CHECK FACTORY VALUE PARAMETER	0.1	---	---
SAVE USER VALVE PARAMETER	0.0	---	---
CHECK USER VALVE PARAMETER	0.1	---	---
RESET	0.0	---	---
OPC CONNECTION OFF	0.1	---	---
WAIT	2.7	---	---
SEARCH SERIAL COM	0.0	---	---
OPC CONNECTION ON	1.8	---	---
SET ATOS MODE	0.1	---	---
TEST INTERNAL ERROR (30.30)	0.1	0.00	PASSED
TEST INTERNAL ERROR (32.01)	0.1	0.00	PASSED
TEST INTERNAL ERROR	0.2	0.00	PASSED
TEST INTERNAL -05V	0.1	20.20	PASSED
TEST INTERNAL -0&P	0.1	20.20	PASSED
TEST INTERNAL -0&S	0.1	20.80	PASSED
TEST INTERNAL -0&V	0.1	10.20	PASSED
TEST INTERNAL -10V	0.2	10.00	PASSED
TEST INTERNAL -10V	0.1	10.00	PASSED
TEST INTERNAL -10V	0.6	10.00	PASSED
TEST INTERNAL -10V OFF	2.8	1.00	PASSED
TEST INTERNAL -10V	0.2	14.00	PASSED
TEST INTERNAL -10V	0.1	10.00	PASSED
TEST INTERNAL -10V	0.1	10.00	PASSED
TEST EXTERNAL -10V1	0.2	14.00	PASSED
TEST EXTERNAL -10V2	0.9	14.10	PASSED
CLOSE G&D INPUT	0.0	---	---
ANALOG IN 1 VOLTAGE SET (REFERENCE 1)	0.0	---	---
TEST ANALOG IN 1 OFF SET (REFERENCE 1) [0V]	1.9	0.00	PASSED
TEST ANALOG IN 1 SCALE + (REFERENCE 1) [+9.9V]	1.7	0.00	PASSED

If the test procedure is in Pause or Pause on Error, follow the below procedure:

- AUTO (Pause on Error) - default**
 the test sequence go to pause when detects an error; in this case press button **1** to redo the current step or press buttons **2** to go the next or previous step. Press button **3** to end the test procedure
- AUTO (End on Error)**
 the test proceed in automatic until the end if not detects errors. It stops and exit to the test procedure when detects an error
- STEP by STEP**
 the test go to in pause when finish the single step. Press button **1** to redo the current step (e.g. when detects an error) or press buttons **2** to go the next or previous step. Press button **3** to end the test procedure

5.4.9 Manual test – during the automatic test procedure

Example: test LEDs (for this test the operator is need)

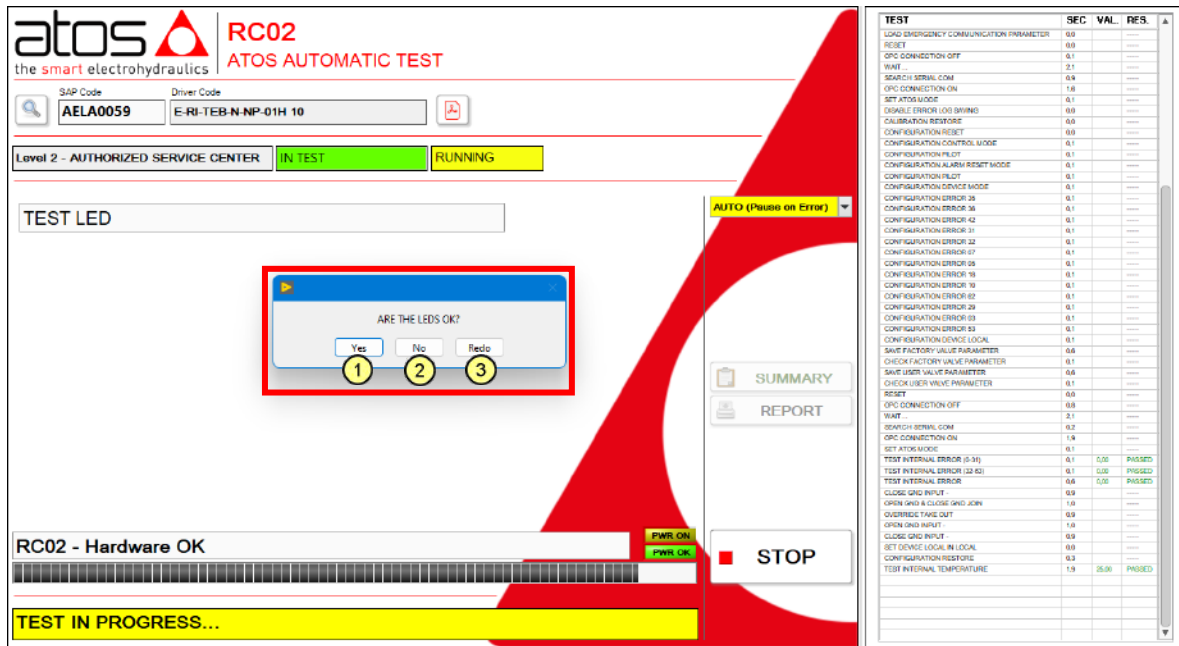

1. Refer the documentation (see 5.4.2) to display the test led sequence (e.g. see the below image):

TEST LED SEQUENCE

	L1	L2	L3
START	OFF	OFF	OFF
1	GREEN	OFF	OFF
2	RED	OFF	OFF
3	OFF	GREEN	OFF
4	OFF	RED	OFF
5	OFF	OFF	GREEN
6	OFF	OFF	RED
7	GREEN	GREEN	GREEN
8	RED	RED	RED
END	OFF	OFF	OFF

ATTENTION:

for EH, EW, EI, EP executions, please check only the led L1 and L3 colour RED (the behaviour of led L1 and L3 colour GREEN is managed by fieldbus master)

2. Depending on the result obtained by the test, press:

- button ① if the test led sequence has been performed correctly
- button ② if is present an error
- button ③ if the test led sequence has to be performed again
-

5.4.10 End test

Once that the test procedure is terminated can appear two different messages:

PASSED

TEST	SEC	VAL	RES.
TEST INTERNAL +9V	0.1	10.00	PASSED
TEST INTERNAL -10V	0.1	10.00	PASSED
TEST INTERNAL +9V OFF	0.1	0.78	PASSED
TEST INTERNAL -10V	0.1	14.98	PASSED
TEST INTERNAL +9V	0.5	15.00	PASSED
TEST INTERNAL +9V	0.1	10.00	PASSED
TEST INTERNAL -10V	0.1	10.00	PASSED
TEST EXTERNAL +9V	0.2	14.98	PASSED
TEST EXTERNAL -10V	0.2	15.00	PASSED
CLOSE GND INPUT	0.9	---	---
ANALOG IN 1 VOLTAGE SET (REFERENCE 1)	0.0	---	---
TEST ANALOG IN 1 OFFSET (REFERENCE 1) [mV]	1.7	0.00	PASSED
TEST ANALOG IN 1 SCALE + (REFERENCE 1) [kPa]	1.6	0.08	PASSED
TEST ANALOG IN 1 SCALE - (REFERENCE 1) [kPa]	1.6	0.08	PASSED
ANALOG IN 1 CURRENT SET (REFERENCE 1)	0.0	0.08	PASSED
TEST ANALOG IN 1 (REFERENCE 1) [mPa]	1.8	0.01	PASSED
TEST ANALOG IN 1 (REFERENCE 1) [mPa]	2.2	10.94	PASSED
ANALOG IN 1 VOLTAGE SET (REFERENCE 1)	0.0	---	---
OPEN GND & CLOSE GND JOIN	1.0	---	---
TEST ANALOG IN 1 DIFF + (REFERENCE 1) [kPa]	2.0	5.28	PASSED
OUTERNEC TIME OUT	1.0	---	---
TEST ANALOG IN 8 OFFSET (FEED 1) [mV]	1.9	0.01	PASSED
TEST ANALOG IN 8 SCALE + (FEED 1) [mPa]	1.7	0.08	PASSED
TEST ANALOG IN 8 SCALE - (FEED 1) [mPa]	1.6	0.08	PASSED
TEST ANALOG IN 8 ALARM (FEED 1)	2.5	---	PASSED
OPEN GND INPUT	0.9	---	---
CLOSE GND INPUT	0.9	---	---
CALIBRATION MONITOR 1 OFF/SET	1.1	0.00	PASSED
CALIBRATION MONITOR 1 SCALE	1.9	0.08	PASSED
TEST MONITOR 15V	1.0	0.00	PASSED
TEST MONITOR 1 +5V	0.7	0.00	PASSED
TEST MONITOR 1 +4V	0.7	0.00	PASSED
TEST MONITOR 120mA	0.6	14.98	PASSED
SET DEVICE LOCAL IN LOCAL	0.9	---	---
TEST CC MONITOR 1	3.3	---	PASSED
TEST NO LOAD MONITOR 1	4.2	---	PASSED
TEST COE 1	1.8	2.00	PASSED
TEST COE 1 OFF	2.8	2.00	PASSED
TEST CC COE 1	4.3	---	PASSED
CONFIGURATION RESTORE	0.3	---	PASSED
TEST INTERNAL TEMPERATURE	0.8	25.00	PASSED
ENABLE ERROR LOG SAVING	0.0	---	---
SAVE FACTORY VALUE PARAMETER	0.6	---	---
CHECK FACTORY VALUE PARAMETER	0.3	---	---
SING USER VALUE PARAMETER	0.6	---	---
CHECK USER VALUE PARAMETER	0.1	---	---
OPC CONNECTION OFF	0.1	---	---
VIPPOWER OFF	1.3	---	---
END	0.0	---	---

Test procedure is passed and all test steps are OK. Press the **OK** button (1) to close the window (the window closes automatically after 10 sec).

FAILED

TEST	SEC	VAL	RES.
TEST INTERNAL +9V	0.1	10.00	PASSED
TEST INTERNAL -10V	0.1	10.00	PASSED
TEST INTERNAL +9V	0.1	10.00	PASSED
TEST INTERNAL +9V OFF	0.1	0.78	PASSED
TEST INTERNAL -10V	0.1	14.98	PASSED
TEST INTERNAL +9V	0.5	15.00	PASSED
TEST INTERNAL +9V	0.1	10.00	PASSED
TEST INTERNAL -10V	0.1	10.00	PASSED
TEST EXTERNAL +9V	0.2	14.98	PASSED
TEST EXTERNAL -10V	0.2	15.00	PASSED
CLOSE GND INPUT	0.9	---	---
ANALOG IN 1 VOLTAGE SET (REFERENCE 1)	0.0	---	---
TEST ANALOG IN 1 OFFSET (REFERENCE 1) [mV]	2.2	0.00	PASSED
TEST ANALOG IN 1 SCALE + (REFERENCE 1) [kPa]	1.6	0.08	PASSED
TEST ANALOG IN 1 SCALE - (REFERENCE 1) [kPa]	1.6	0.08	PASSED
ANALOG IN 1 CURRENT SET (REFERENCE 1)	0.0	0.08	PASSED
TEST ANALOG IN 1 (REFERENCE 1) [mPa]	2.4	0.01	PASSED
TEST ANALOG IN 1 (REFERENCE 1) [mPa]	1.7	10.94	PASSED
ANALOG IN 1 VOLTAGE SET (REFERENCE 1)	0.0	---	---
OPEN GND & CLOSE GND JOIN	0.9	---	---
TEST ANALOG IN 1 DIFF + (REFERENCE 1) [kPa]	1.9	5.28	PASSED
OUTERNEC TIME OUT	0.9	---	---
TEST ANALOG IN 8 OFFSET (FEED 1) [mV]	1.6	11.81	FAILED
TEST ANALOG IN 8 SCALE + (FEED 1) [mPa]	1.8	11.81	FAILED
TEST ANALOG IN 8 SCALE - (FEED 1) [mPa]	1.6	11.81	FAILED
TEST ANALOG IN 8 ALARM (FEED 1)	1.7	---	PASSED
OPEN GND INPUT	1.0	---	---
CLOSE GND INPUT	0.9	---	---
TEST MONITOR 15V	1.1	0.00	PASSED
TEST MONITOR 1 +5V	0.7	0.00	PASSED
TEST MONITOR 1 +4V	0.7	0.00	PASSED
TEST MONITOR 120mA	0.6	14.98	PASSED
SET DEVICE LOCAL IN LOCAL	0.9	---	---
TEST CC MONITOR 1	3.3	---	PASSED
TEST NO LOAD MONITOR 1	3.7	---	PASSED
TEST COE 1	1.8	2.00	PASSED
TEST COE 1 OFF	2.8	2.00	PASSED
TEST CC COE 1	4.3	---	PASSED
CONFIGURATION RESTORE	0.3	---	PASSED
TEST INTERNAL TEMPERATURE	0.8	25.00	PASSED
ENABLE ERROR LOG SAVING	0.0	---	---
SAVE FACTORY VALUE PARAMETER	0.6	---	---
CHECK FACTORY VALUE PARAMETER	0.3	---	---
SING USER VALUE PARAMETER	0.6	---	---
CHECK USER VALUE PARAMETER	0.1	---	---
OPC CONNECTION OFF	0.2	---	---
VIPPOWER OFF	1.4	---	---
END	0.0	---	---

Test procedure is failed: error conditions occur during the test procedure have been detected. Press the **OK** button (2) to close the window (the window closes automatically after 10 sec).

All test steps (pass and fail) are available on test summary window (see 5.4.11).

5.4.11 Test summary

When test procedure is terminated or stopped, press test summary button (see 5.1) and the below window opens:

Test Name	Repeat	Duration	Result	Comm.	Hardw.
POWER SUPPLY BENCH CHECK	1	0.0	PASS	PASS	PASS
TEMPERATURE BENCH CHECK ①	1	0.0	PASS	PASS	PASS
VOLTAGE CHECK VP	1	0.2	PASS	PASS	PASS
POWER CHECK VP	1	0.2	PASS	PASS	PASS
READ HARDWARE CODE	1	0.1	PASS	PASS	PASS
READ FIRMWARE VERSION	1	0.3	PASS	PASS	PASS
READ SERIAL NUMBER	1	0.3	PASS	PASS	PASS
READ LIFE TIMER	1	0.1	PASS	PASS	PASS
CALIBRATION READ MONITOR 1 OFFSET	1	0.1	PASS	PASS	PASS
CALIBRATION READ MONITOR 1 SCALE	1	0.1	PASS	PASS	PASS
TEST INTERNAL ERROR (0-31)	1	0.3	PASS	PASS	PASS
TEST INTERNAL ERROR (32-63)	1	0.1	PASS	PASS	PASS
TEST INTERNAL ERROR	1	0.0	PASS	PASS	PASS
TEST INTERNAL +24VL	1	0.4	PASS	PASS	PASS

FAIL TEST ② Of Test Fail 5 ③ Total Time 00:02:11 × CLOSE

1. double click on control ① to see the details of the single test in the main window
2. press button ② to display only the failed test steps
3. the indicator ③ displays the number of failed test

5.4.12 Report

When test procedure is terminated or stopped, press report button (see 5.1) and the below document opens.

①		Atos spa  the smart electrohydraulics	
ATOS AUTHORIZED SERVICE CENTER			
AUTOMATIC TEST REPORT			
Reference:	E-RI-TEB-N-NP-01H 10		
Serial No.:	544756	Operator:	C118
Date/Time:	02/05/2022 17:24	Serial Bench:	M000000030
Test Result:	PASSED		
Tests Performed:			
Test	Value	Result	
POWER SUPPLY BENCH CHECK	24,11 Volt	PASSED	
TEMPERATURE BENCH CHECK	39,71 °C	PASSED	
VOLTAGE CHECK VP	24,00 Volt	PASSED	
POWER CHECK VP	2,81 Watt	PASSED	
READ HARDWARE CODE	13698304	PASSED	
READ FIRMWARE VERSION	D08.0000#BTEB002000	PASSED	
READ SERIAL NUMBER	544756	PASSED	
READ LIFE TIMER	0d 10h 36m	PASSED	
CALIBRATION READ MONITOR 1 OFFSET	0	PASSED	
CALIBRATION READ MONITOR 1 SCALE	32400	PASSED	
TEST INTERNAL ERROR (0-31)	0	PASSED	
TEST INTERNAL ERROR (32-63)	0	PASSED	
TEST INTERNAL ERROR	0	PASSED	
TEST INTERNAL +24VL	23,70 Volt	PASSED	
TEST INTERNAL +24VP	23,70 Volt	PASSED	
TEST INTERNAL +24VS	24,00 Volt	PASSED	
TEST INTERNAL +5V	5,26 Volt	PASSED	
TEST INTERNAL +15V	14,88 Volt	PASSED	
TEST INTERNAL -15V	-15,00 Volt	PASSED	
TEST INTERNAL +10V	10,00 Volt	PASSED	
TEST INTERNAL -10V	-10,00 Volt	PASSED	
TEST INTERNAL +15V OFF	0,78 Volt	PASSED	
TEST INTERNAL -15V	14,88 Volt	PASSED	
TEST INTERNAL -15V	-15,00 Volt	PASSED	
TEST INTERNAL +10V	10,00 Volt	PASSED	
TEST INTERNAL -10V	-10,00 Volt	PASSED	
TEST EXTERNAL +15VT	14,88 Volt	PASSED	
TEST EXTERNAL -15VT	-15,12 Volt	PASSED	
TEST ANALOG IN 1 OFFSET (REFERENCE 1) [0V]	0,00 Volt	PASSED	
TEST ANALOG IN 1 SCALE + (REFERENCE 1) [+9.9V]	9,88 Volt	PASSED	
TEST ANALOG IN 1 SCALE - (REFERENCE 1) [-9.9V]	-9,85 Volt	PASSED	
TEST ANALOG IN 1 (REFERENCE 1) [4mA]	4,01 mA	PASSED	
TEST ANALOG IN 1 (REFERENCE 1) [19mA]	18,99 mA	PASSED	
TEST ANALOG IN 1 DIFF + (REFERENCE 1) [+9.9V]	5,28 Volt	PASSED	
TEST ANALOG IN 6 OFFSET (FEED T) [0V]	0,01 Volt	PASSED	
TEST ANALOG IN 6 SCALE + (FEED T) [+9.9V]	9,89 Volt	PASSED	
TEST ANALOG IN 6 SCALE - (FEED T) [-9.9V]	-9,86 Volt	PASSED	
TEST ANALOG IN 6 ALARM (FEED T)	1000 - 0	PASSED	
CALIBRATION MONITOR 1 OFFSET	0,00 Volt	PASSED	
CALIBRATION MONITOR 1 SCALE	9,00 Volt	PASSED	
TEST MONITOR 1 0V	0,00 Volt	PASSED	
TEST MONITOR 1 +9V	9,00 Volt	PASSED	
TEST MONITOR 1 -9V	-8,99 Volt	PASSED	
TEST MONITOR 1 4mA	4,06 mA	PASSED	

Page 1 of 2

 The Report document is a text file and it is open in Word format (Microsoft® Word program has to be installed on PC).

 The Report document can be printed.

 In the area ① will be show the company logo or the text previously set (see 5.3.4).

6 SETTING FILE DOWNLOAD PROCEDURE

ATTENTION: only for digital drivers and axis controls the test procedure erases all setting parameters! Before to start the test procedure, it is recommended save the user parameters (see 4.3.1).

Setting file download procedure is available only for E-SW and Z-SW - level 7 functionality.

Once terminated the test, follow the below procedure to restore the parameters:

6.1 Switch off the driver/axis control and go to **OFF-LINE** mode.
Press **SETTING FILE ARCHIVE** button

6.2 Press **Atos Archive** button

6.3 Press **Search** button

6.4 Insert Valve Code in **Component Code** field and press button on the right

6.5 If Setting File Name is found, press **OK** button.
If Setting File Name is not found, contact ele-support@atos.com

6.6 Press **Load** button

For more details see also 4.3.2

6.7 If Driver Code has no option, jump to step 6.8
 If Driver Code has options, modify Driver Code

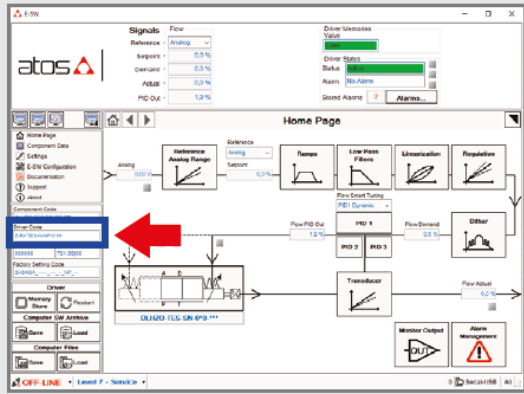

6.8 Insert Component Code

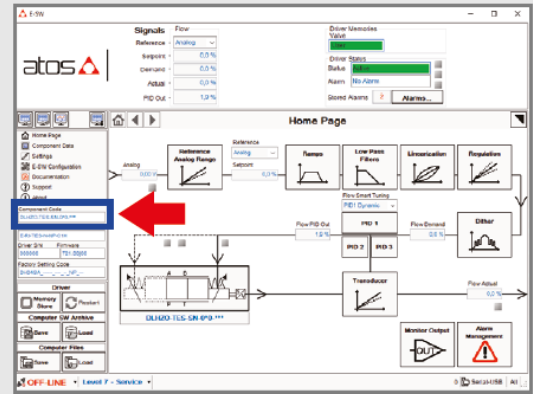

6.9 Switch on the driver/axis control and go to **ON-LINE** mode.

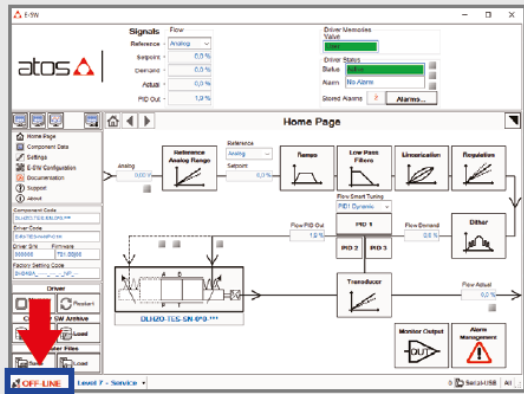

6.10 Press **Download** button and afterwards press **OK** button

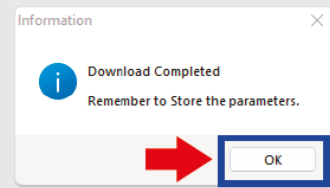
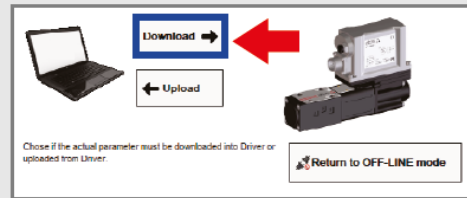

6.11 Press **Memory Store** button

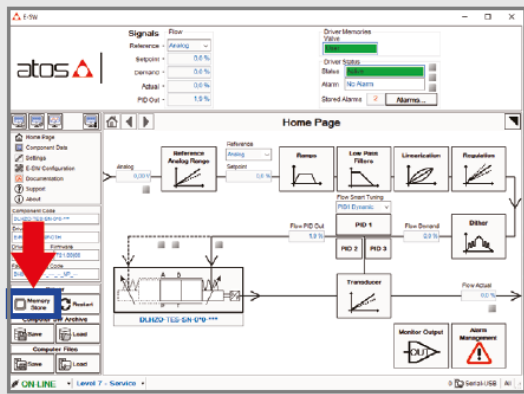

6.12 Press **Store All** button

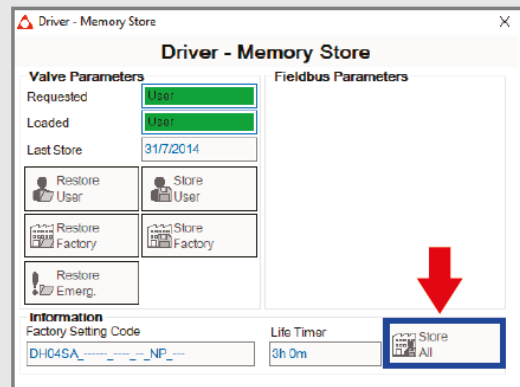

6.13 Press **Restart** button

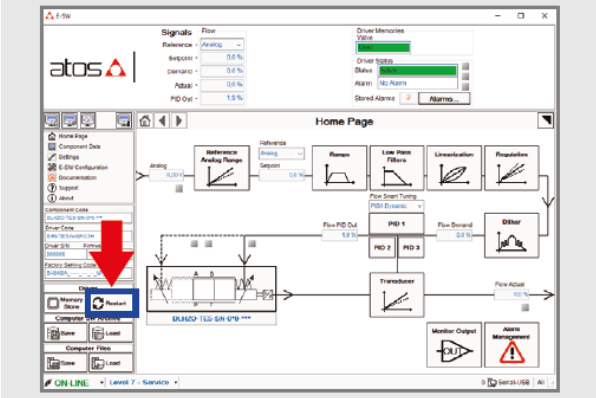

6.14 If required by the customer, download customer setting and press **Memory Store** button

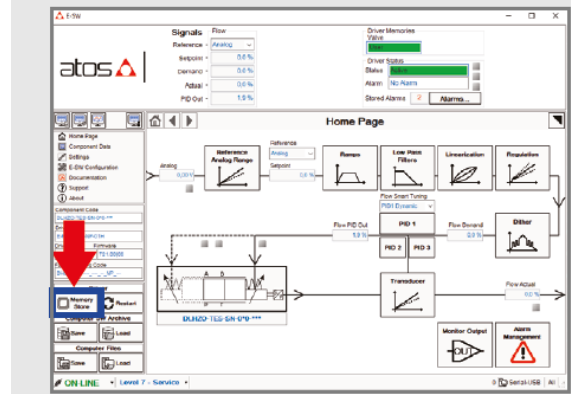

For more details see also 0

6.15 Press **Store User** button

