

S-MAN-S-BP

SMART SERVOPUMP SYSTEM SERIES 20
PROGRAMMING INSTRUCTIONS
PROFIBUS DP PROTOCOL



INDEX

1	GENERAL	3
1.1	About this user manual.....	3
1.2	Documentation	3
1.3	Trademarks	4
1.4	Abbreviations.....	5
2	ABOUT PROFIBUS DP – PROFIBUS FIELDBUS	7
2.1	PROFIBUS – RS485	7
2.2	PROFIBUS – DPV0.....	7
3	PROFIBUS RS485 - PHYSICAL LAYER	8
3.1	Topology	8
3.2	Cables	9
3.3	Communication connector.....	9
4	PROFIBUS DP CONFIGURATION	10
4.1	Node configuration	10
5	PROFIBUS DP SERVICES	12
5.1	PROFIBUS message description	12
5.2	Parametrization Data: PKW	12
5.3	Process Data Object (PZD).....	15
6	OBJECT DICTIONARY	18
6.1	Manufacturer specific profile area	18
7	SCALING DESCRIPTION	21
7.1	Internal resolution scaling.....	21
7.2	VALUE_to_Physical scaling	21
7.3	Gain scaling.....	21
8	BITS PARAMETERS DESCRIPTIONS	22
8.1	Status Word - 32bit.....	22
8.2	Control Word - 32bit	25
9	CONFIGURATION FILE (GSD)	26

1 GENERAL

1.1 About this user manual

This manual describes the required information to operate Atos Smart Servopump system (SSP) using PROFIBUS fieldbus communication: always refer to the specific drive manual (see 1.2) for a complete description of the available function and of the parameters settings.

To speed up the fieldbus startup operations it is always recommended to use the Atos S-SW-SETUP programming software for PC before connecting Atos SSP to the fieldbus: S-SW-SETUP programming software allows a fast identification of the functions and parameters that would be included in the PROFIBUS communication.

The purpose of this manual is not to cover all the details or variations of PROFIBUS fieldbus, Atos drive and software, and it does not provide complete details for all possible working conditions; if any further information or technical support are required, please contact the Technical Sales Support of Atos Electronic Division (ele-support@atos.com).

In addition please follow up all the current regulations of the country/community where the drives will be used.

A basic skill in using personal computers and Windows® operating system is required.

 For information about mechanical and electrical installation of a complete SSP system (drives, motors, pumps, fuses, inductances and wiring cable) please refer dedicated manual S-MAN-HW - see 1.2

1.2 Documentation

Additional information about electronic drives, motor, pump and Atos software can be found into the Atos web site or in the My Atos - Download Area.

Related documentations

- S-MAN-S-SW SSP programming software – user manual
- S-MAN-HW SSP system installation - user manual
- AS050 Basics for Smart Servopumps - SSP - technical table
- AS100 Smart Servopumps - SSP- technical table
- AS200 Sizing criteria for Servopumps - technical table
- AS300 PGI - Cast iron internal gear pumps for SSP servopumps- technical table
- AS350 PGIL - Aluminium internal gear pumps for SSP servopumps - technical table
- AS400 PMM – Electric motors for SSP servopumps - technical table
- AS500 D-MP – Digital electronic drives for SSP servopumps - technical table
- AS800 Programming tools for pumps & servopumps – technical table
- AS810 Accessories for SSP servopumps - technical table
- AS910 Operating and maintenance information for SSP servopumps - technical table
- GS510 Fieldbus features

Other standards

- IEC 61158 Digital data communication for measurement and control – industrial
- IEC 61784 (CPF3) Profile sets for continuous/discrete manufacturing relative to industrial fieldbus

1.3 Trademarks

All Atos trademarks [™] and [®] are distinctive sign of Atos rights, know-how, and in general intellectual properties. Partial or full-unauthorized reproduction of this manual, images, logos, or casting through internet, may be object of punishment by local law.

Upon delivery, all installed software is copyright-protected. The software may only be reproduced with our written consent or in accordance with the license agreement.

Windows[®] is a registered trademark of Microsoft Corporation

Pentium[®] is a registered trademark of Intel Corporation

EtherCAT[®] is registered trademark and patented technology, licensed by Beckhoff Automation GmbH, Germany

Beckhoff[®] and TwinCAT[®], are registered trademarks of and licensed by Beckhoff Automation GmbH

PROFIBUS[™], PROFINET[™] and PROFIsafe[™], as well as the relevant logos, are registered trademarks of PROFIBUS Nutzerorganisation e.V. (PNO) SIMATIC is a registered trademark of SIEMENS AG

1.4 Abbreviations

Abbreviation	Description
AK	Request/response identifier
D	Derivative
DA	Destination Address
Dcfg	Derivative Configuration
DSAP	Destination Service Access Point
DTM	Device Type Manager
DU	Data Units
ED	End Delimiter
EDDL	Electronic Device Description Language
EMC	ElectroMagnetic Compatibility
EMCY	Emergency
ESD	ElectroStatic Discharge
FB	Function Block
FC	Frame Control
FCS	Frame Check Sequence
FDL	Fieldbus Data Link
FF	Feed Forward
FMMU	Fieldbus Memory Management Unit
FMS	Fieldbus Message Specification
FTP	Fluid Power Technology
GSD	General Station Description
HMI	Human Machine Interface
I	Integral
IEC	International Electrotechnical Commission
IND	Index
ISO	International Standard Organization
L	Load
LE	Net Data Length
LEr	Length Repeater
LSB	Less Significant Byte
LVL	Level
MAC	Medium Access Control
MB	Memory Byte
MSB	Most Significant Byte
MW	Memory Word
NRZ	Non Return to Zero
OSI	Open Systems Interconnection
P	Proportional
PAB	Peripheral output byte
PAW	Peripheral output word
PDO	Process Data Object
PDU	Protocol Data Unit
PEB	Peripheral input byte
PEW	Parameter input word
PKE	Parameter identifier
PKW	Parameter signature / value (Parameter-Kennung / Wert)
PNO	Profibus Network Organization
PNU	Parameter Number
PPO	Parameter Process data Object
Profibus	PROcess FieldBUS
Profibus DP	Device Peripheral
Profibus FMS	Fieldbus Messages Automation

Profibus PA	Process Automation
PTO	Profibus trade Organization
PWE	Parameter value
PWM	Pulse Width Modulation
PZD	Process data area
PKW	Parameter signature / value (Parameter-Kennung / Wert)
Res	Reserved
RO	Read Only
SA	Source Address
SAP	Service Access Point
SC	Single character
SDO	Service Data Object
SDN	Send Data with No acknowledge
ST	Structured Text
SRD	Send and Request Data with acknowledge
SD	Start Delimiter
SSAP	Source Service Access Point
SYN	SYnchroNizing
T	Transfer
TSDR	Time Send and Request Data with acknowledge
TWD	Time WatchDog
UDP	User Datagram Protocol
USB	Universal Serial Bus
WD	WatchDog
WKC	Working Counter
↑	Active on rising edge

2 ABOUT PROFIBUS DP – PROFIBUS FIELDBUS

In modern machines Industrial fieldbus systems sets the communication between electronic central unit, electromechanic and electrohydraulic servoactuators, transducers and all the electric/electronic accessories of the application.

As for other Industrial fieldbus systems, the use of PROFIBUS interface on the Atos drives introduces the following advantages:

- **Lower installation costs** standard 2-wires connection allows drastic cost reduction in comparison to the conventional "one to one" wiring of standard analog components.
- **Improved Safety** an elevated immunity to the electromagnetic interferences is performed due to the small number of the electric connections and the galvanic insulation (by optoisolators) between the fieldbus and the power devices.
- **Improved expandability** the adding of new components in fieldbus network requires only wiring to the bus and software configuring - no change on the control panel and no addition of cables on the machine is required.
- **Standardization** all the connected devices talk with the control unit "speaking the same language": devices of different builders with the same function are easily interchangeable.

2.1 PROFIBUS – RS485

PROFIBUS is a serial high-speed communication interface that was originally designed for industry automation application.

PROFIBUS standard includes different possible physical medium for the serial transmission, described in:

'Physical Layer' (ISO/OSI communication lev.1)

Atos drives use the RS485 serial communication as most of the industrial devices.

See 3 and IEC 61158 standard specification

2.2 PROFIBUS – DPV0

PROFIBUS DP is the definition of all the services and objects available for the communication between devices connected to the fieldbus.

PROFIBUS DP standard includes definitions of:

'Data Link Layer' (ISO/OSI communication lev.2)

Atos drives implement only DPV0 protocol services for master-slave cyclic data exchange

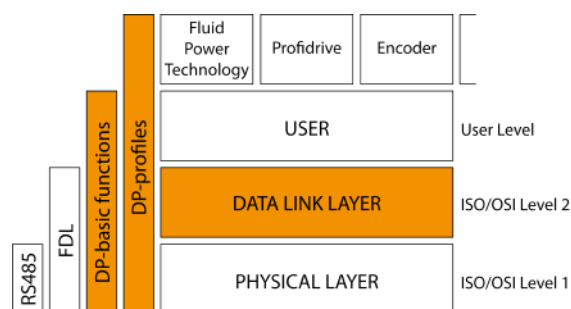
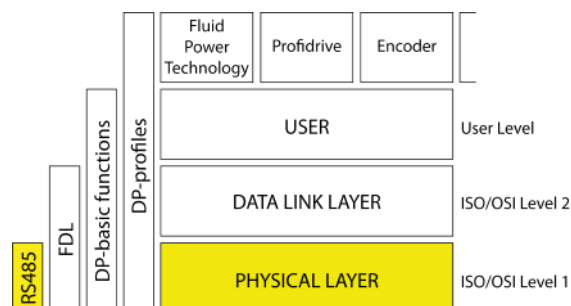

 To optimize protocol efficiency PROFIBUS includes some aspect of the 'Application Layer' (ISO/OSI communication lev.7) in the Data Lin Layer definition

3 PROFIBUS RS485 - PHYSICAL LAYER

PROFIBUS physical layer defines all the relevant aspects data signals transmission between devices connected to the network (always refer to IEC 61158-2 standard specification).

3.1 Topology

PROFIBUS DP network has the structure of linear bus, composed by a main cable (“Trunk”) with several stations (“Nodes”) and passive Terminator at both ends; “Nodes” are wired to the main cable by another short cable (max 30 cm) called “Stub”.

 For fieldbus versions, the software permits drive's parameterization through serial RS485 communication port also if the drive is connected to the central machine unit via fieldbus.

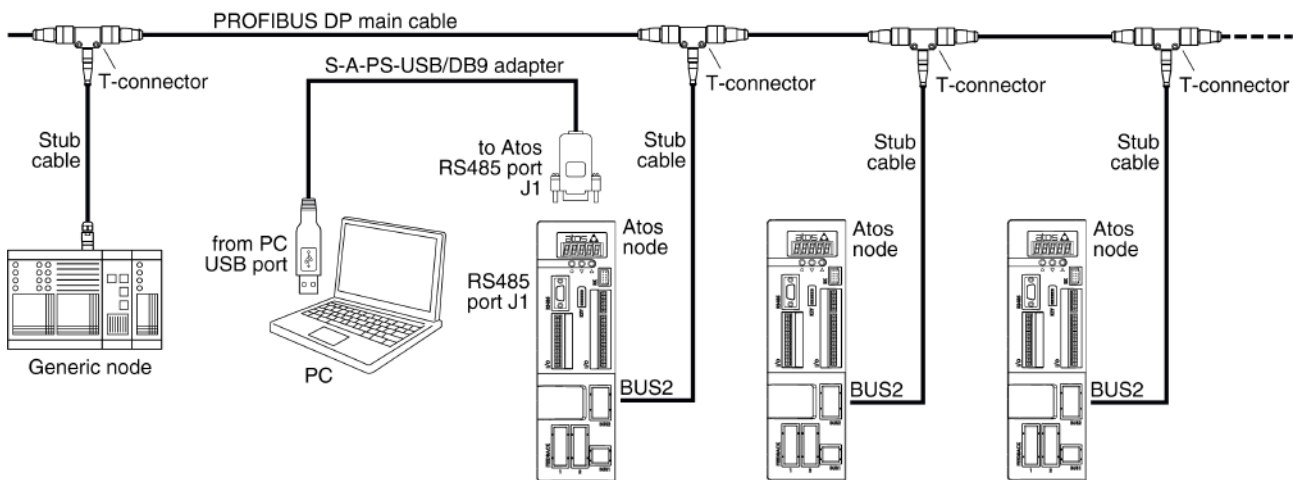

Tree-structures are not permitted.



“Stub” lines should be as short as possible.



Max Nodes up to 125.

Depending on the number of stations connected, the bus level can drop so far that not even the minimum signal-to-noise ratio required for safe data transmission is maintained, in these cases specific signal repeaters are required.



Passive terminator resistors (220Ω between lines + 390Ω pull up/down to lines V+/GND) are required at both ends of the “Trunk” to avoid transmission errors (signal reflections) during data exchange. Too many bus terminators also cause problems, since each connection presents an electrical load to the bus and thus consumes drive power.

When using line repeaters the terminator must be installed for each line segment.

3.2 Cables

According to standard specification a shielded twisted pair cable must be used for PROFIBUS RS485 network: the best choice of the cable depends on many factors e.g. node number, max. transmission baud rate, line length, etc.

For example:

Parameter	DP, Cable type A
Surge impedance in Ω	135...165 for a frequency of 3...20 MHz
Effective capacitance (pF/m)	≤ 30
Loop resistance (Ω /km)	≤ 110
Core design (solid)	AWG 22/1
Core design (flexible)	$> 0,32 \text{ mm}^2$

- in some applications, several bus connectors are used at electrically short distances: a minimum cable length between two stations of 1m/ 3feet is recommended
- use of baudrates greater than 1.5 MBaud requires special connectors. The connector must have built in Inductors in order to run with higher baudrates

Transmission Rate [Kbit/s]	Range per Segment [m]
9,6	1200
19,2	1200
45,45	1200
93,75	1200
187,5	1000
500	400
1500, 3000, 6000	200
12000	100



Cable length includes the total of trunk cable + all stub line lengths.



The use of repeaters may be required for bus lengths greater than 1.2 km and with more than 32 stations.

3.3 Communication connector

For BP executions (PROFIBUS DP) fieldbus communication connector is always available for digital drive. To connect the drive into the PROFIBUS DP fieldbus network use dedicated DB9 - pin 9 connector.

CONNECTOR	PIN	SIGNAL	TECHNICAL SPECIFICATIONS	NOTES
BUS2 	1	SHIELD	Shield	
	2	NC	-	Do not connect
	3	LINE_B	Bus line (B)	
	4	DE	Control's signal for repeater	
	5	DGND	Data line and termination signal zero	
	6	+5V	Termination supply signal	
	7	NC	-	Do not connect
	8	LINE_A	Bus line (A)	
	9	NC	-	Do not connect



No master device must be active in a PROFIBUS DP fieldbus when using S-SW-SETUP software to communicate with connected drive.

4 PROFIBUS DP CONFIGURATION

4.1 Node configuration

Through S-SW-SETUP it is possible to set the following parameters:

Name	Description
NODE_SLAVE_ADDR	PROFIBUS node number
DATA_CONSISTANCE	Consistency of the data exchanged
EN_ACYCLIC_DATA	Enable PKW parametrization or not

And check the status of the profibus slave node:

Name	Description
FLDB_STATE	Fieldbus node status: WAIT_PRM = waiting for programming WAIT_CFG = waiting for configuration DATA_EX = data exchange in progress ERROR = node error

After completing the configuration:

- use STORE USER button of the S-SW-SETUP (see S-MAN-SW manual)
- switch the drive off and then on again.

The drive, seen as the slave PROFIBUS node, is able to automatically search for the transmission speed of the PROFIBUS master among the values shown in table at section 3.2; each speed also includes an indication of the maximum length of each segment in the PROFIBUS network.



Image below is referred at the “Network management > Configuration” S-SW-SETUP software page.

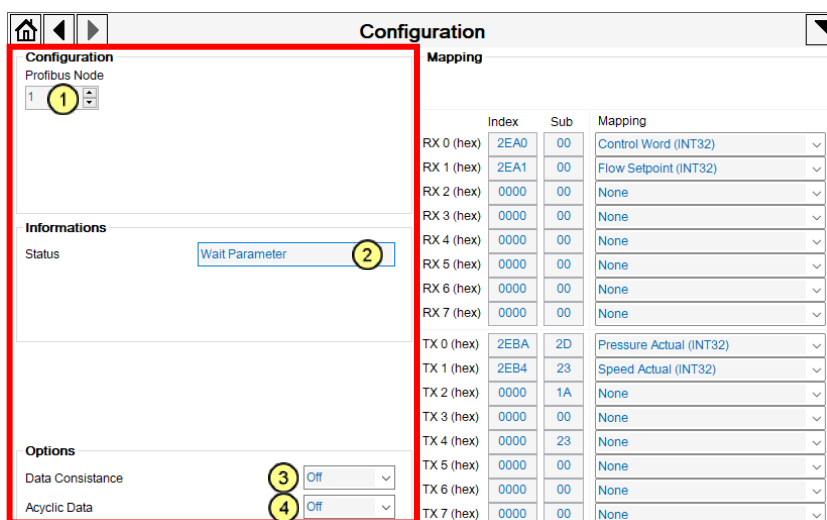

Profibus Node

The control ① allows to set the unique drive identification into the fieldbus (see S-MAN-SW).

Min	1
Max	126
Default	125



Node 126 is used as service node.

The S-SW-SETUP cannot communicate with drives with address 126.



Use 'Store User' parameter button to save the new Node into the drive permanent parameters: new node will be applied at the next drive power-on.

The 'Profibus Node' is not downloaded by setting files.



Update S-SW-SETUP configuration before reconnecting the drive.

Status

The indicator ② allows to display the status of the fieldbus communication.

Data Consistance

The control ③ allows to enable or disable the consistency of the data exchanged.

option1	Off
option2	On
Default	Off

Acyclic Data

The control ④ allows to enable or disable PKW parametrization.

option1	Off
option2	On
Default	Off

5 PROFIBUS DP SERVICES

5.1 PROFIBUS message description

The profibus message is sent cyclically from the master to the drive. The request to the drive consists of two parts:

PROFIBUS message:

PKW	PZD
0 or 4 words	0 or 10 words

- PKW: parametrization data
- PZD: process data

The response from the drive to the master is composed in the same way.

The PKW part may be enabled or not.

The PZD part may be completely programmed in terms of word number and meaning.

5.2 Parametrization Data: PKW

The PKW message part has a fixed length (4 words), and makes it possible to change the drive parameters. If the application does not require any parameter change, it is sufficient to set the field AK = 0 (No Task). The other fields are automatically disregarded.

The PKW message is composed as follows:

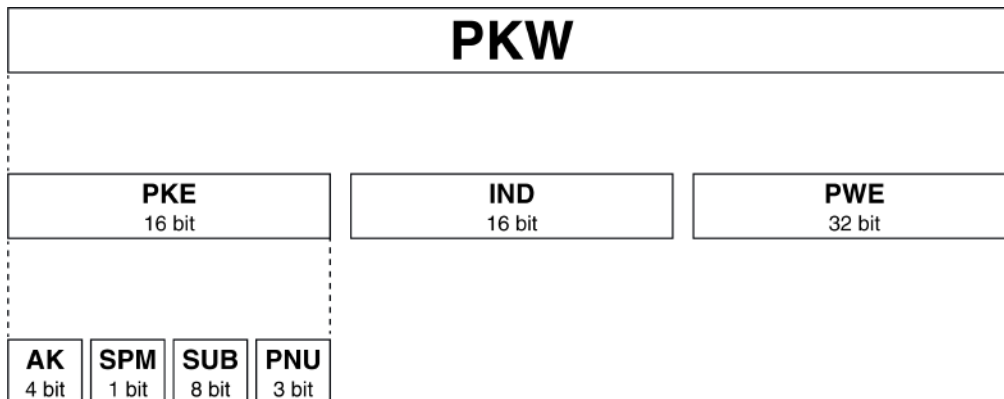

The following description includes all the functions and parameter types allowed by SSP.

AK

The AK field contains the operation to be performed. Valid values for the request from the master to the drive:

AK	Description
0	No task
2	Word reading
3	Double word reading
5	Word writing
6	Double word writing

Valid values for the response from the drive to the master:

AK	Description
0	No task
2	Word reading
3	Double word reading
5	Word writing
6	Double word writing
14	Operation not allowed

If the drive responds with a code **14** (operation not allowed), the PWE field specifies an error code:

PWE	Description
4	Non-existent parameter
5	Type of operation not allowed

PNU

The PNU field contains the type of parameter involved. The following table shows the values of the AK and PNU fields of the profibus message for reading and writing operations:

Description	Bit No.	Read (AK)	Write (AK)	PNU
Manufacturer specific profile area	16 or 32	2-3	5-6	7

IND - SUB

In order to access required object in the manufacturer specific profile area it is necessary to set the index in the IND field and the subindex in the SUB field.

PWE

The PWE field contains the selected size value.

It is possible to send the most significant (Big-Endian) or the least significant (Little-Endian) byte first, using the configuration parameter "EN_BIG_ENDIAN" of S-SW.

Examples:**Reading of the rotation speed (Index 0x2EB4 – Sub = 00)**

Field	dec. value	exadec. value	Description
AK	3	03 H	Double word reading
PNU	7	07 H	CAN Dictionary
IND	11956	2E B4 H	object index
SUB	00	00 H	object subindex

Request MS > SL:

PKE	IND	PWE
30 07	2E B4	00 00 00 00

Response SL > MS:

PKE	IND	PWE
30 07	2E B4	00 01 86 A0

Therefore the read value is 000186A0h=100000

2EB4 is a direct value in mRPM, so the speed is 100 RPM.

Indicare dove possono vedere le scalature

Writing ControlWord (Index 0x2EA0 – Sub = 00)

Field	dec. value	exadec. value	Description
AK	6	06 H	Double word writing
PNU	7	07 H	CAN Dictionary
IND	11936	2E A0 H	object index
SUB	00	00 H	object subindex

Request MS > SL:

PKE	IND	PWE
60 07	2E A0	00 00 00 0F

Response SL > MS:

PKE	IND	PWE
60 07	2E A0	00 00 00 0F

The Drive responds ok, with the value written .

5.3 Process Data Object (PZD)

The PZD message part contains the data which have to be exchanged cyclically between master and slave: I/O, diagnostics. Through the configuration page of the S-SW it is possible to select which and how many words to exchange, bearing in mind that the items that can be mapped are listed in the manufacturer specific profile area.

For the process area configuration:

- Programme the objects being received and transmitted by indicating the index and sub-index of the objects in the Dictionary CAN (the sub-index is the array index)
- Store parameters: use STORE USER button of the S-SW (see S-MAN-SW manual)
- Switch the drive off and then on again

5.3.1 Mapping

It's possible to map the desired objects with S-SW at the "Network management > Configuration" S-SW software page (see image below) that allow mapping up to 8 objects both in transmission and reception.

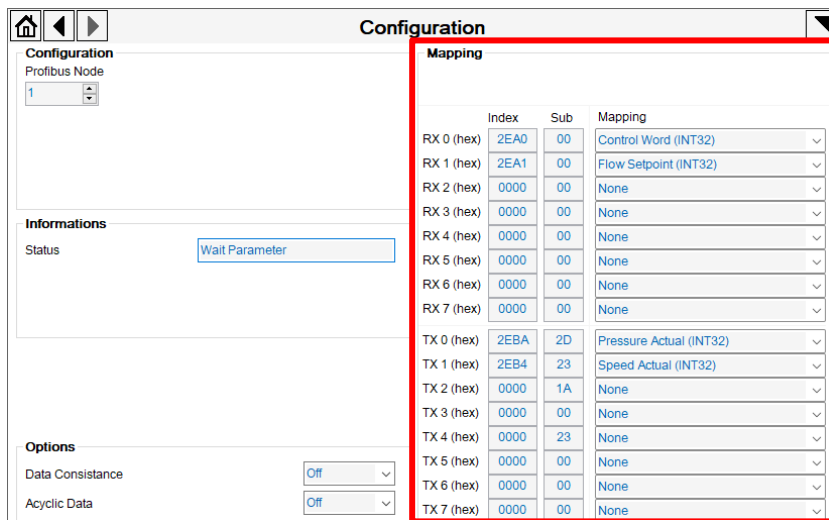

5.3.2 Input data mapping (RX)

Name	Description
RX0_INDEX	Receive Object0 Index
RX0_SUB_INDEX	Receive Object0 Sub-Index
RX1_INDEX	Receive Object1 Index
RX1_SUB_INDEX	Receive Object1 Sub-Index

.....

RX7_INDEX	Receive Object7 Index
RX7_SUB_INDEX	Receive Object7 Sub-Index

5.3.3 RX mapping

Parameter	Index	SubIndex	Data Type
Control Word	2EA0	00 h	UNSIGNED32
Flow Setpoint	2EA1	00 h	INTEGER32
Pressure Setpoint	2EA2	00 h	INTEGER32

RX mapping example:

Name	Index	Description
RX0_INDEX	2EA0	Control Word 32bit
RX0_SUB_INDEX	0	
RX1_INDEX	2EA1	Flow Setpoint Fieldbus
RX1_SUB_INDEX	0	

5.3.4 Output data mapping (TX)

Name	Description
TX0_INDEX	Transmit Object0 Index
TX0_SUB_INDEX	Transmit Object0 Sub-Index
TX1_INDEX	Transmit Object1 Index
TX1_SUB_INDEX	Transmit Object1 Sub-Index

.....

.....

TX7_INDEX	Transmit Object7 Index
TX7_SUB_INDEX	Transmit Object7 Sub-Index

5.3.5 TX mapping

Parameter	Index	SubIndex	Data Type
Flow Setpoint Analog	2EB0	00 h	INTEGER32
Flow Demand	2EB3	00 h	INTEGER32
Speed Actual	2EB4	00 h	INTEGER32
Speed Error	2EB5	00 h	INTEGER32
Pressure Setpoint Analog	2EB6	00 h	INTEGER32
Pressure Demand	2EB9	00 h	INTEGER32
Pressure Actual	2EBA	00 h	INTEGER32
Pressure Error	2EBB	00 h	INTEGER32
Pressure PID Feed Forward	2EBC	00 h	INTEGER16
Pressure PID Proportional	2EBD	00 h	INTEGER16
Pressure PID Integral	2EBE	00 h	INTEGER16
Pressure PID Derivative	2EBF	00 h	INTEGER16
Pressure PID Output	2EC0	00 h	INTEGER32
Speed Demand	2EC1	00 h	INTEGER32
Status Word	2EC2	00 h	UNSIGNED32
Q Input Actual	2EC3	00 h	INTEGER16
P Input Actual	2EC4	00 h	INTEGER16
TR1 Actual	2EC5	00 h	INTEGER32
Drive IGBT Temperature	2EC6	00 h	INTEGER16
Drive Radiator Temperature	2EC7	00 h	INTEGER16
Drive CPU Temperature	2EC8	00 h	INTEGER16
Motor Temperature	2EC9	00 h	INTEGER16
Drive DC Bus Voltage	2ECA	00 h	INTEGER16
Stator Voltage	2ECB	00 h	INTEGER16
Power Actual	2ECC	00 h	INTEGER16
Flux Current PID Output	2ECD	00 h	INTEGER16
Torque Current PID Output	2ECE	00 h	INTEGER16
Torque Current Demand	2ECF	00 h	INTEGER16
Torque Current Actual	2ED0	00 h	INTEGER16
Flux Current Demand	2ED1	00 h	INTEGER16
Flux Current Actual	2ED2	00 h	INTEGER16
Motor Total Current Actual	2ED3	00 h	INTEGER16

TX mapping examples:

Name	Index	Description
TX0_INDEX	2EB4	Speed actual
TX0_SUB_INDEX	0	
TX1_INDEX	2EBA	Pressure actual
TX1_SUB_INDEX	0	

6 OBJECT DICTIONARY

6.1 Manufacturer specific profile area

Directly from the graphical interface of the S-SW software, it is possible to access information useful for the development of fieldbus communication by simply clicking with the mouse on a selected parameter or pressing CTRL+H on the PC keyboard.

Mouse click- example:

Click right button of the mouse on **Unit** control (1) or **Min Input** control (2) to open the related fieldbus communication windows (3) and (4).

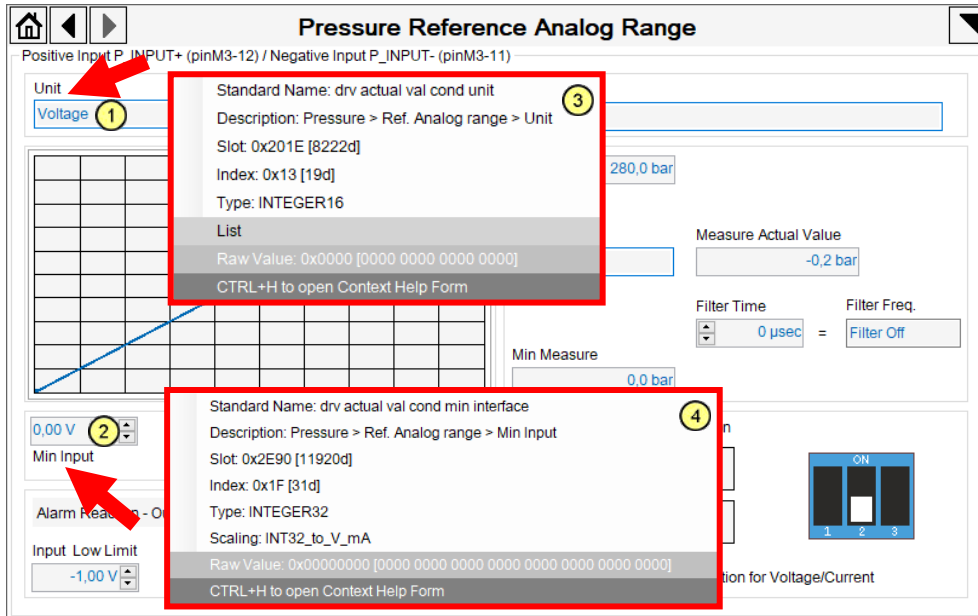

Windows (3) and (4) shown all fieldbus information of selected parameter:

Standard Name:	Parameter name
Description:	Parameter fast reference to S-SW software and drive manual descriptions
Slot:	Parameter address
Index:	Parameter address
Type:	Parameter dimension and data type
Scaling:	Parameter scaling value (see 7 and 7.2)
List:	Parameter list value
Raw Values	Numeric parameter
CTRL+H	Press CTRL+H to open Context Help Form (see CTRL+H - example)

(1) Pass mouse arrow on **List** (5) to display the information

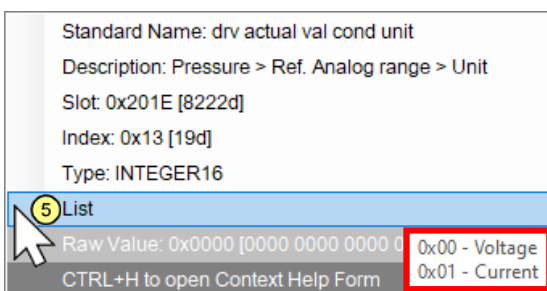

CRTL+H - example:

The information in Context Help Form window are the same as described above for the "mouse click - example".

By pressing CTRL+H on PC keyboard the Context Help Form windows opens.

Once the window has been opened with CTRL + H, it always remains active until it is closed by the user.

In this way it is possible to view the fieldbus information of each single parameter present on the software page, simply by positioning the mouse over it.

If no parameter is selected the fields of the window will be appears empty.

Example: no parameter selected

The screenshot shows the 'Pressure Reference Analog Range' configuration window. The 'Unit' is set to 'Voltage'. The 'Type' is 'Pressure'. The 'Max Measure' is 350,0 bar and the 'Min Measure' is 1462763,5 bar. The 'Measure Actual Value' is 1464805,8 bar. The 'Polarity' is 'Normal'. The 'Filter Time' is 0 µsec and the 'Filter Freq.' is 'Filter Off'. The 'Input Actual Value' is 10,00 V. The 'Input Low Limit' is -1,00 V and the 'Input High Limit' is 11,00 V. The 'Alarm Reaction - Out Of Limits' is 'Warning'. The 'Wizard Reference Configuration' shows 'Voltage Standard' and 'Current 4..20 mA'. The 'Information' window is open but empty.

Pass the mouse on a parameter to display all fieldbus communication information related to it.

Example: "Polarity" parameter selected

The screenshot shows the 'Pressure Reference Analog Range' configuration window with the 'Polarity' parameter selected. The 'Information' window is open and displays the following details for 'Polarity':
 Standard Name: drv actual val cond sign
 Description: Pressure > Ref. Analog range > Polarity
 Slot: 0x2E91 [11921d] Index: 0x21 [33d]
 Type: INTEGER16
 List: [L] Polarity
 Raw Value: d: 1 h: 0x0001
 b: 0000 0000 0000 0001

7 SCALING DESCRIPTION

7.1 Internal resolution scaling

These scaling convert 'Raw' value with internal resolution formats in 'Real' value [Real Unit]:

Scale	Gain Raw to Real	Gain Real to Raw	Real Unit
Raw_mbar	1	1	mbar
Raw_mrpm	1	1	mrpm
Raw_μsec	1	1	μsec
Raw_mHz	1	1	mHz
Raw_msec	1	1	msec
Raw_mm	1	1	mm
INT16_to_A_X16	0,0625	16	A
INT16_to_V_X16	0,0625	16	V
INT16_to_°C_X16	0,0625	16	°C
INT16_to_kW_X16	0,0625	16	kW
INT16_to_Perc200	200 / 32767	32767 / 200	%
UINT16_msec_to_sec	0,001	1000	sec
INT32min_to_gg_hh_mm	1	1	min
INT16_to_V_mA	0,0001	10000	V
	0,0002	5000	mA
8192_to_200Perc	200 / 8192	8192 / 200	%

$$Real_Value [Real Unit] = Gain_Raw_to_Real * Raw_Value$$

$$Raw_Value = Gain_Real_to_Raw * Real_Value [Real Unit]$$

7.2 VALUE to Physical scaling

These scaling depend by the input interface. In the below table are described the input interface types:

Input interface	Scaling	Measure Unit
Pressure	RAW_mbar	mbar
Speed	RAW_mrpm	mrpm

7.3 Gain scaling

These scalings convert 32bits 'raw' values into a Gain factor with unit indication if required:

Scale	Real Full Scale	Real Unit
INT32_to_Gain	1	none

The function use the two words of value to calculate the gain real value:

$$Raw\ Value \quad \boxed{A_raw: (Most\ Significant\ Word)} \quad \boxed{B_raw: (Less\ Significant\ Word)}$$

where for Gain function:

$$Real_Gain = (A_raw / B_raw) * Real_Fullscale$$

8 BITS PARAMETERS DESCRIPTIONS

8.1 Status Word - 32bit

Slot	2EC2h	Index	00h
------	-------	-------	-----

Conditions:

MSB								
Bit	31-28	27	26	25	24	23-22	21-20	19-16
Content	Res	STO Test Suggested	STO Corrupted	STO Active	Smart Cooling Active	Smart Selection	Pressure PID Selection	Res

LSB								
15	14	13-12	11	10	9	8	7	6-0
Drive Running	Control Error	Res	Internal Limit Reached	Pressure Target Reached	Local	Power Limitation Active	Warning	Status

Status

The first seven bits 6-0 indicate the functional status of the electronic drive:

Status value (bits 6-0)	
Not reredy to switch on	0xx 0000
Switch on disable	1xx 0000
Ready to switch on	01x 0001
Switched on	01x 0011
Operation enabled	01x 0111
Quick stop active	00x 0111
Fault reaction active	0xx 1111
Fault	0xx 1000

Warning

Bit 7 indicates the presence of alarm or error conditions:

Warning (bit 7)	
Normal working	0
Error/Alarm present	1

Power Limitation Active

Bit 8 indicates if the control (Power Limitation Active) is active or not active:

Power Limitation Active (bit 8)	
Not active	0
Active	1

Local

Bit 9 indicates if the drive status is actually controlled by fieldbus (see 8.2 – control word) or not:

Local (bit 9)	
Local (internal) control	1
Remote (fieldbus) control	0

Pressure Target Reached

Bit 10 indicates when the actual regulated pressure has reached the demanded value:

Pressure target reached (bit 10)	
Not reached	0
Reached	1

Limit Touched

Bit 11 indicates when the demanded pressure value is out of limit:

Limit Touched (bit 11)	
Limit not touched	0
Limit touched	1

Control Error

Bit 14 indicates when a pressure error is present:

Control Error (bit 14)	
Normal working	0
Control error present	1

Drive running

Bit 15 indicates when the drive is running:

Drive running (bit 15)	
Drive stop	0
Drive running	1

Pressure PID Selection

Bits 21-20 indicate which PID parameters set is active for pressure control:

Pressure PID selection (bits 21-20)	
PID1	00
PID2	01
PID3	10
PID4	11

Smart Selection

Bits 23-22 indicate which smart parameters set is active for smart control:

Pressure PID selection (bits 21-20)	
Dynamic	00
Balanced	01
Smooth	10

Smart Cooling active

Bit 24 indicates if the control (Smart Cooling) is active or not active:

Smart Cooling active (bit 24)	
Not active	0
Active	1

STO active

Bit 25 indicates if the STO function is active or not active:

STO active (bit 24)	
Not active	0
Active	1

STO corrupted

Bit 26 indicates if the STO function is corrupted or not corrupted:

STO corrupted (bit 26)	
Not corrupted	0
Corrupted	1

STO test suggested

Bit 27 indicates if the STO test is suggested or not suggested:

STO test suggested (bit 27)	
No suggested	0
Suggested	1

8.2 Control Word - 32bit

Slot	2EA0h	Index	00h
------	-------	-------	-----

Conditions:

MSB				LSB			
Bit	31-17	16	15-14	13-12	11	10-8	7-0
Content	Res	Alarm Reset	Smart Selection	Pressure PID Selection	Enable P/Q Control	Res	Control

Control

The first eight bits 7-0 allow to request the transition of the drive status to a defined condition:

Command	Control Word Bits					Transition
	Bit 7	Bit 3	Bit 2	Bit 1	Bit 0	
Shutdown	0	X	1	1	0	2, 6, 8
Switch on	0	0	1	1	1	3
Switch on + enable operation	0	1	1	1	1	3 + 4 (*)
Disable voltage	0	X	X	0	X	7, 9, 10, 12 (**)
Quick stop	0	X	0	1	X	7, 10, 11
Disable operation	0	0	1	1	1	5
Enable operation	0	1	1	1	1	4, 16
Fault reset		X	X	X	X	15

(*) Automatic transition to enable operation state after executing switched on state functionality

(**) Automatic transition to switch ON disable after the quick stop ramp is elapsed

Note: bits 6, 5, 4 of the controlword are not used.

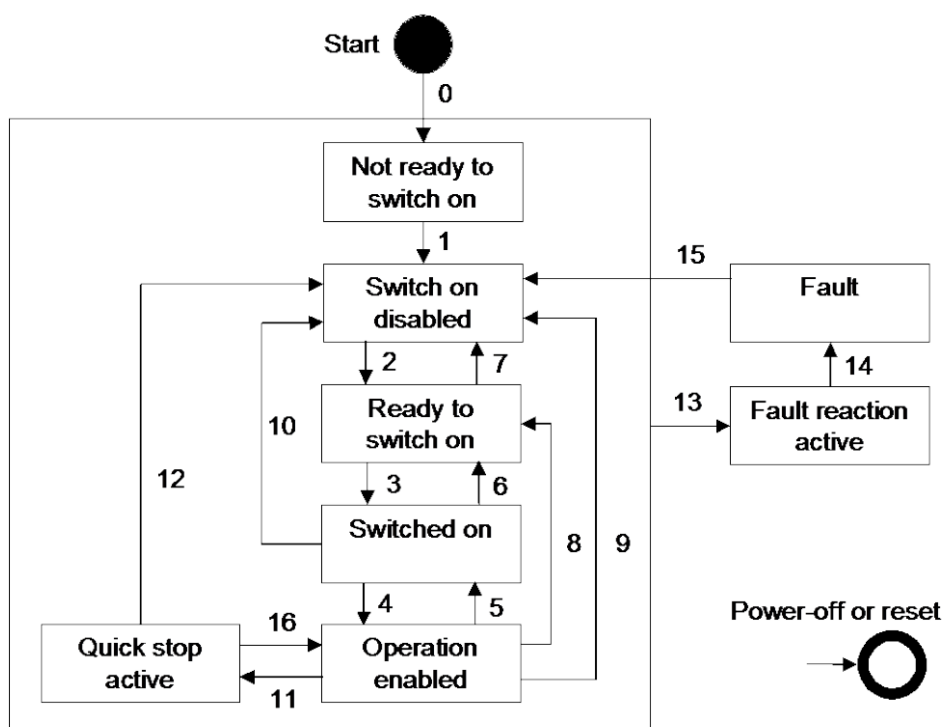

Enable P/Q Control

Bit 11 allows to select the Enable when the alternated control is active:

Enable P/Q Control (bit 11)	
Speed control active	0
Alternated control active	1

Pressure PID Selection

Bits 13-12 allows to select the active Pressure PID parameters set:

Pressure PID selection (bits 13-12)	
PID1	00
PID2	01
PID3	10
PID4	11

Smart Selection

Bits 15-14 indicate which smart parameters set is active for smart control:

Smart Tuning (bits 15-14)	
Dynamic	00
Balanced	01
Smooth	10

Alarm Reset

Bits 16 allows to clear all alarms present into the drive:

Alarm Reset (bits 16)	
Alarm reset	

9 CONFIGURATION FILE (GSD)

An electronic description of Atos drives PROFIBUS characteristics is available through GSD (General Station Description) files configuration. These files, included in MyAtos, is ASCII text that contains device-specific data, such as, vendor identification information, supported baud rates, supported message length, number of input/output data, meaning of diagnostic messages, timing information, plus options and features supported, data formats, and available I/O signals.

For modular PROFIBUS systems, a GSD file may contain several configurations (one for each I/O module), one of which will be found valid during start-up.

Configuration software utilizes the GSD files (device master data) of the connected slaves to create the master parameter record that is then transferred or downloaded to the class 1 master.

