

Cast iron internal gear pumps for SSP servopumps

fixed displacement, high pressure



PGI are fixed displacement cast iron internal gear pumps designed for high pressure application and are suitable for use in SSP system with variable speed drives to provide variable flow rate.

Their particular design allows outstanding efficiencies due to radial and axial gap compensation, low pressure pulsation and very low noise level.

The internal gear is supported by a hydrodynamic/hydrostatic lubrication film, which allows operation at low viscosities and low/high speeds.

Max displacement: up to **100 cm³/rev**

Max pressure: up to **330 bar**

1 MODEL CODE

PGI	-	2	020	/	1	D	*	/	PE
Internal gear pump							Series number		Seals material: PE = FKM
Size, see section 2:								Direction of rotation, viewed at the shaft end: D = clockwise	
1, 2, 3, 4								Shaft, SAE Standard: 1 = keyed	
Displacement (cm ³ /rev), see section 2:									
011, 016, 020, 025, 032, 040, 050, 064, 080, 100									

2 HYDRAULIC CHARACTERISTICS - based on mineral oil ISO VG 46 at 50 °C

Size code	1		2					3			4			
Displacement code	011	016	020	025	032	040	050	064	080	100	050	064	080	100
Displacement (cm ³ /rev)	10,8	15,6	20	24,5	31,6	39,5	49,5	65,3	80,4	100,5	50,6	65,3	80	101,2
Continuous pressure (bar)	330	330	330	330	330	280	280	280	280	280	330	315	300	300
Peak pressure (1) (bar)	350	350	350	350	350	300	300	290	290	290	340	330	330	330
Recommended pressure on inlet port (bar)	from 0,8 to 2 (absolute pressure)													
Max speed (2) (rpm)	4000	4000	3400	3200	3000	3600	3600	3000	3000	3000	2400	2400	2200	2200
Volumetric efficiency (3)	93	95	93	93	94	95	95	94	95	95	93	94	94	95
Hydromechanical efficiency (3)	92	93	91	92	92	93	93	92	93	93	89	89	90	90
Noise (3) (dBA)	58	60	62	63	64	65	66	69	70	71	73	74	75	76

(1) 15% duty cycle, max 10 sec continuously

(2) For SSP system max speed please consider table AS200;

(3) Measuring data with: n = 1450 rpm; Δp = 250 bar;

3 GENERAL CHARACTERISTICS

Assembly position	Any position.
Loads on the shaft	Axial and radial loads are not allowed on the shaft
Ambient temperature range	-20°C ÷ +80°C
Compliance	REACH Regulation (EC) n°1907/2006

4 HYDRAULIC FLUIDS - for other fluids not included in below table, consult our technical office

Fluid temperature	-20°C ÷ +80°C		
Recommended viscosity	10 ÷ 300 mm ² /s - max at cold start 2000 mm ² /s		
Max fluid contamination level	normal operation	ISO4406 class 20/18/13 NAS1638 class 9	see also filter section at www.atos.com or KTF catalog
	longer life	ISO4406 class 18/16/11 NAS1638 class 7	
Hydraulic fluid	Classification		Ref. Standard
Mineral oils	HL, HLP, HLPD, HVLP, HVLPD		DIN 51524

5 DIAGRAMS at 1450 rpm (based on mineral oil ISO VG 46 at 40°C)

5.1 Efficiency

Efficiency is the ratio of useful output energy in relation to the input energy fed to a component.

In fluid power, pump efficiency can split in two different contributes:

- hydro-mechanical efficiency (η_{hm}), that describes the losses created by frictional forces (both mechanical and viscous)
- volumetric efficiency (η_v), that accounts for the flow leakages of a pump

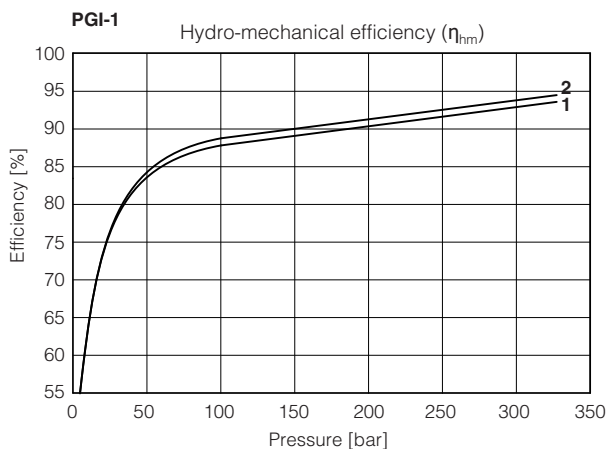

1 = PGI-1011 2 = PGI-1016

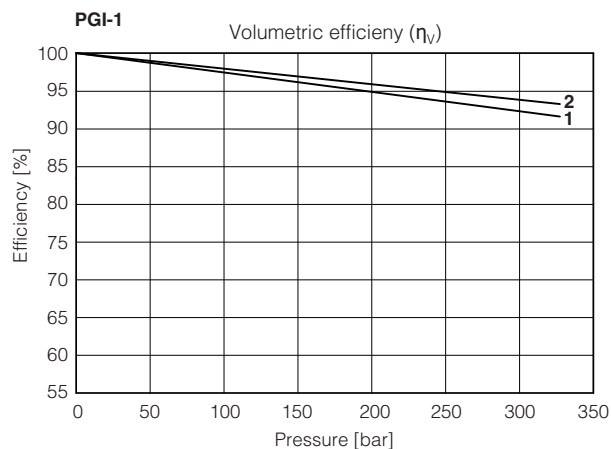

1 = PGI-1011 2 = PGI-1016

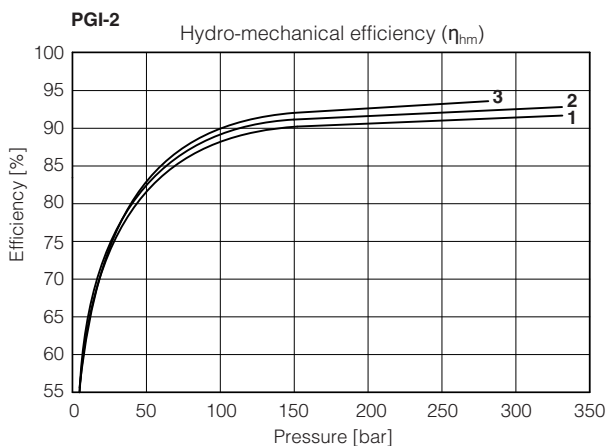

1 = PGI-2020 2 = PGI-2025; PGI-2032
3 = PGI-2040; PGI-2050

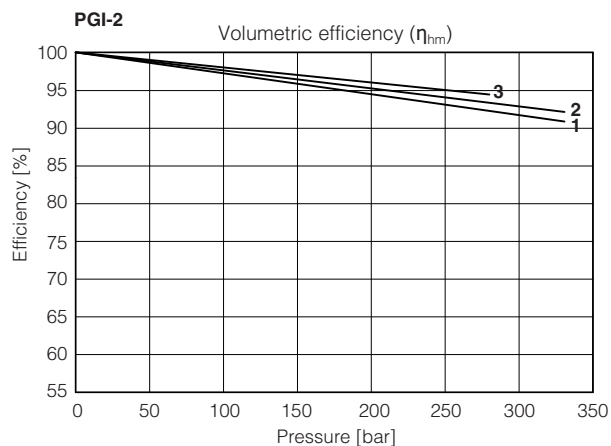

1 = PGI-2020; PGI-2025 2 = PGI-2032
3 = PGI-2040; PGI-2050

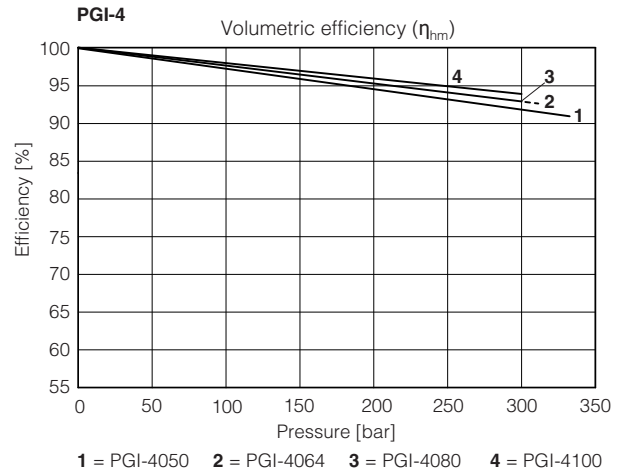
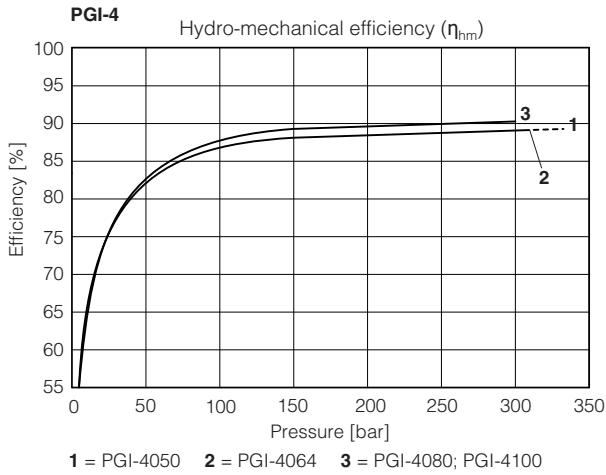
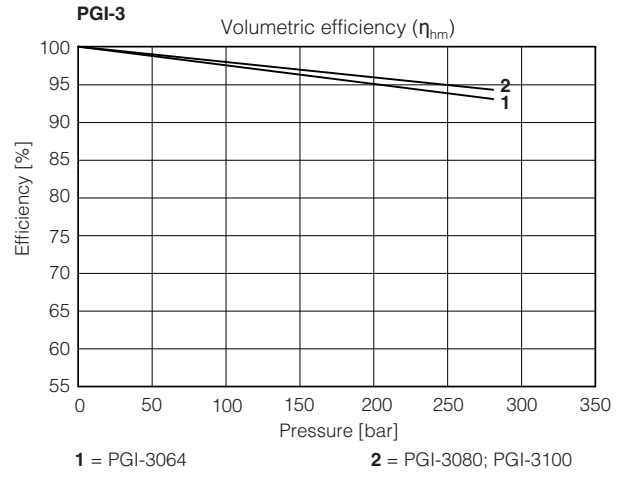
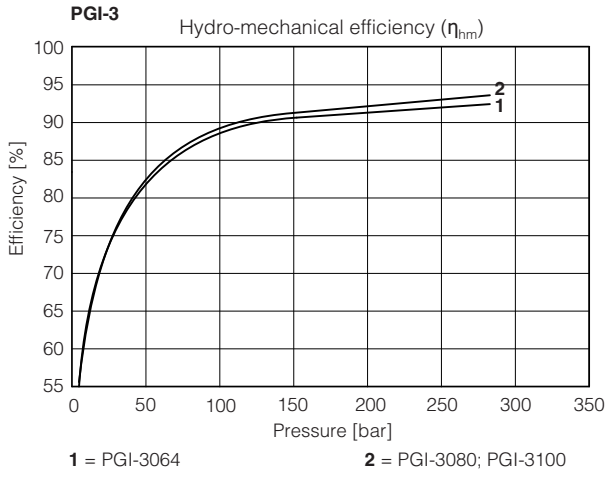

5.2 Noise level

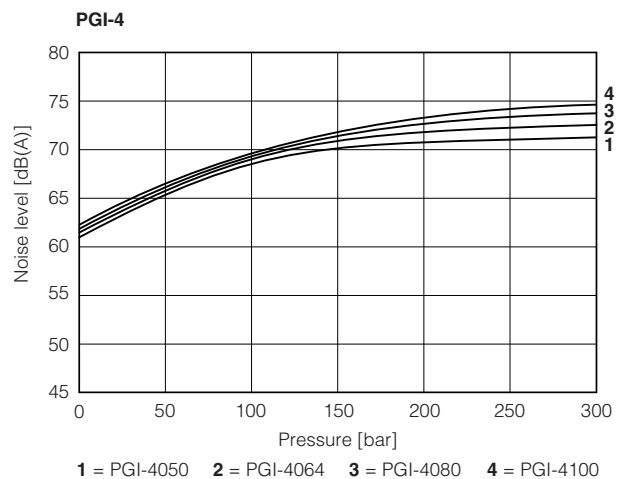
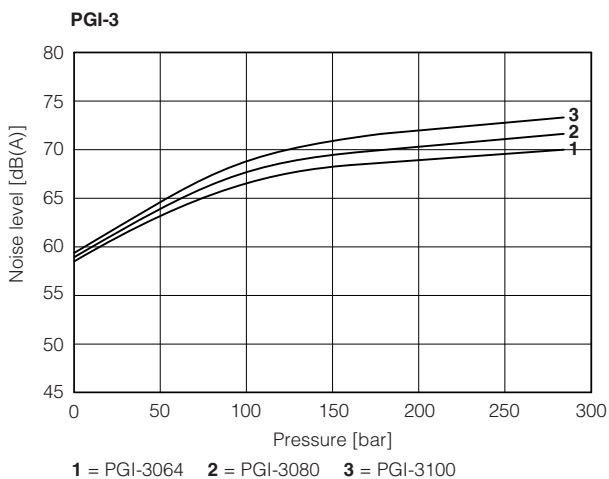
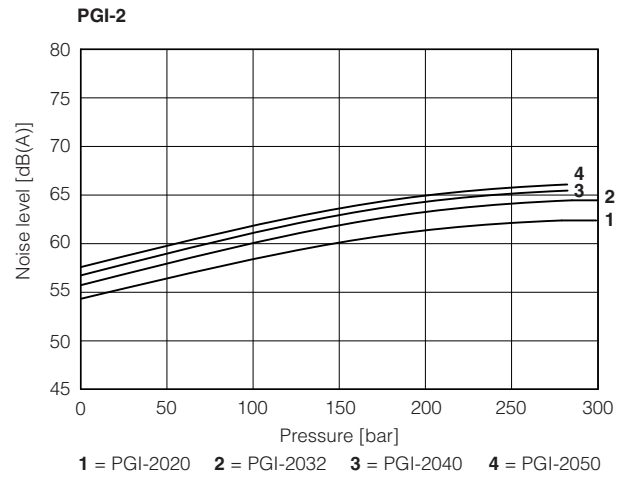
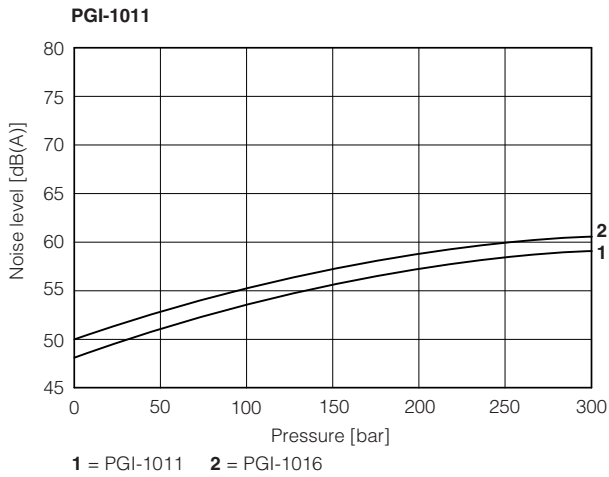

6 DIMENSIONS

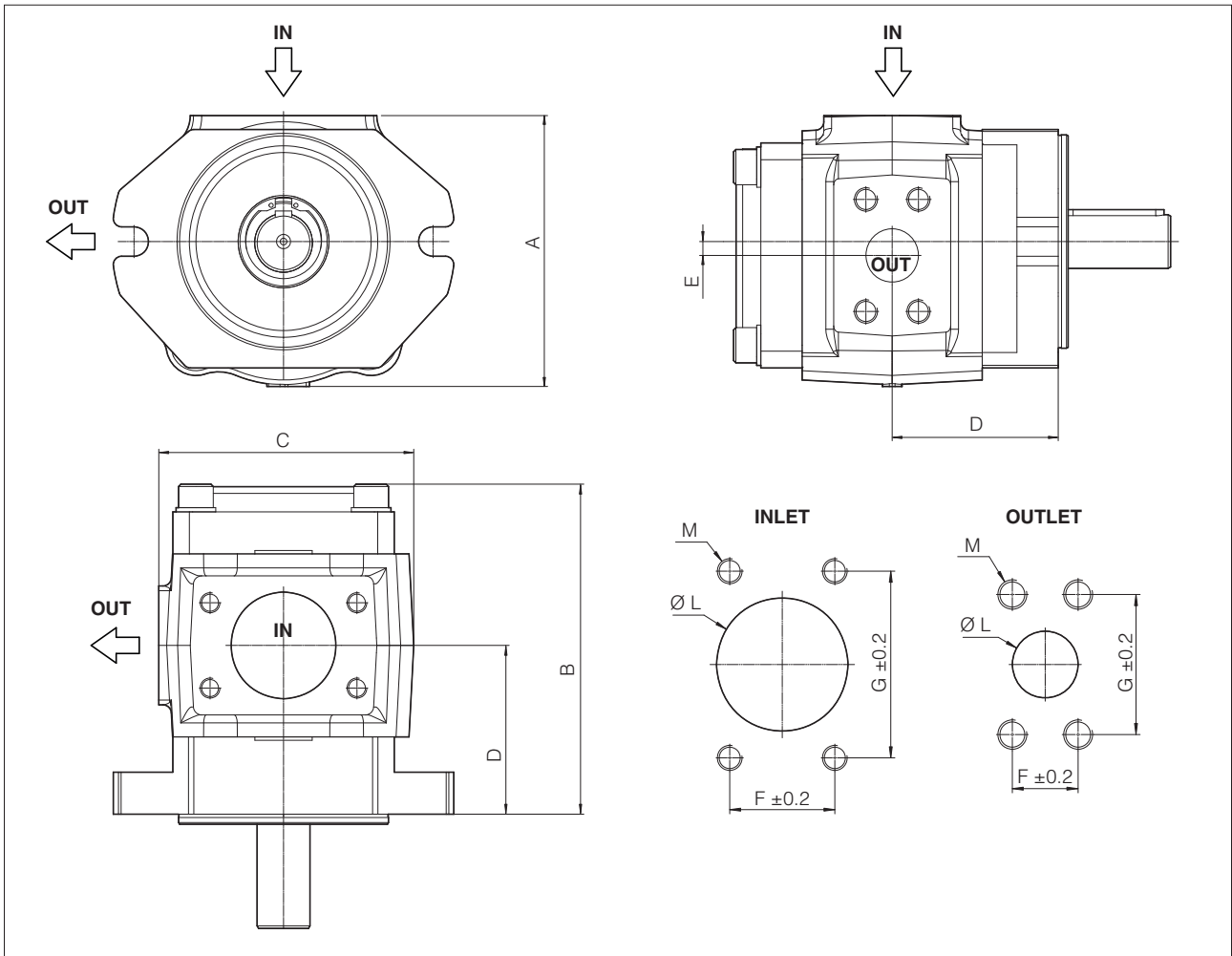

Pump code	Dimensions [mm]															Mass [kg]
	A	B	C	D	E	INLET port					OUTLET port					
						F	G	L	M	SAE Flange	F	G	L	M	SAE Flange	
PGI-1011	110	125	106	60.5	5.5	26.2	52.4	25	M10x15	1" SAE3000	17.5	38.1	14	M8x15	1/2" SAE3000	5.4
PGI-1016	110	135	106	65.5	5.5	26.2	52.4	25	M10x15	1" SAE3000	17.5	38.1	14	M10x17	1/2" SAE3000	5.7
PGI-2020	126	158	129	75	6.5	30.2	58.7	32	M10x17	1 1/4" SAE3000	22	47.5	18	M10x17	3/4" SAE3000	10.5
PGI-2025	126	165	129	78.2	6.5	30.2	58.7	32	M10x17	1 1/4" SAE3000	22	47.5	18	M10x17	3/4" SAE3000	11.2
PGI-2032	126	175	129	83.2	6.5	30.2	58.7	32	M10x17	1 1/4" SAE3000	22	47.5	18	M10x17	3/4" SAE3000	12
PGI-2040	135	186	138	88.7	6.5	42.9	77.8	51	M12x17	2" SAE3000	26.2	52.4	20	M10x17	1" SAE3000	15
PGI-2050	135	200	138	95.7	6.5	42.9	77.8	51	M12x17	2" SAE3000	26.2	52.4	20	M10x17	1" SAE3000	17
PGI-3064	160	168.5	155	86.5	8.3	42.9	77.8	51	M12x21	2" SAE3000	27.8	57.2	25.4	M12x22	1" SAE6000	15.3
PGI-3080	160	180.5	155	92.5	8.3	42.9	77.8	51	M12x21	2" SAE3000	31.8	66.7	31.75	M14x24	1 1/4" SAE6000	17.5
PGI-3100	160	196.5	155	100.5	8.3	50.8	88.9	63.5	M12x21	2 1/2" SAE3000	31.8	66.7	31.75	M14x24	1 1/4" SAE6000	18.7
PGI-4050	198	186	192.5	86.5	9.8	35.7	69.9	40	M12x25	1 1/2" SAE3000	27.8	57.2	20	M12x22	1" SAE6000	32
PGI-4064	198	195	192.5	91	9.8	35.7	69.9	40	M12x25	1 1/2" SAE3000	27.8	57.2	20	M12x22	1" SAE6000	34
PGI-4080	198	204	192.5	95.5	9.8	42.9	77.8	50	M12x25	2" SAE3000	31.8	66.7	30	M14x25	1 1/4" SAE6000	36
PGI-4100	198	217	192.5	102	9.8	42.9	77.8	50	M12x25	2" SAE3000	31.8	66.7	30	M14x25	1 1/4" SAE6000	39

7 RELATED DOCUMENTATION

AS050	Basics for Smart Servopumps - SSP	AS800	Programming tools for pumps & servopumps
AS100	SSP Smart Servopumps	AS810	Accessories for servopumps
AS200	Sizing criteria for servopumps	AS910	Operating and maintenance information for servopumps
AS320	PGIX cast iron double internal gear pumps	GS510	Fieldbus
AS350	PGIL aluminium internal gear pumps	S-MAN-HW	Servopumps installation manual
AS400	PMM high performance synchronous servomotors	S-MAN-SW	Servopumps programming software manual
AS500	D-MP electronic drives		