

Hydraulic cylinders type CH - square heads with counterflanges

to ISO 6020-2 - nominal pressure 16 MPa (160 bar) - max 25 MPa (250 bar)

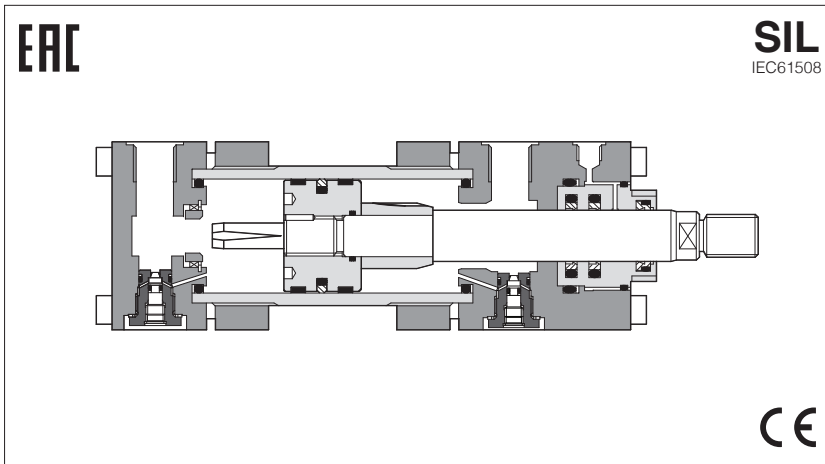

CH cylinders have engineered double acting construction, designed to suit the requirements of industrial applications: top reliability, high performances and long working life.

- Bore sizes from **63** to **200** mm
- Adjustable or fixed cushioning
- Optional built-in position transducer, **see tab. B310**
- Attachments for rods and mounting styles, **see tab. B800**
- CH cylinders are **SIL** compliance with IEC 61508 (TÜV certified), certification on request

For cylinder's choice and sizing criteria **see tab. B015**

1 MODEL CODE

CH	P	/	10	-	63	/	28	/	28	*	0500	-	S	3	0	1	-	A	-	B1E3X1Z3	**
Cylinder series CH to ISO 6020 - 2																					Series number (1)
Rod position transducer - = omit if not requested F = magnetosonic M = magnetosonic programmable N = magnetostrictive P = potentiometric V = inductive Transducer available on request, contact our technical office																					Heads' configuration (2) , see section 13 Oil ports positions B* = front head X* = rear head Cushioning adjustments positions, to be entered only if adjustable cushioning are selected E* = front head Z* = rear head * = selected position (1, 2, 3 or 4)
Incorporated subplate , see section 15 - = omit if subplate is not requested 10 = size 06 20 = size 10 30 = size 16 40 = size 25																					Options (2): Rod end, see section 7 F = female thread G = light female thread H = light male thread Oversized oil ports, see section 11 D = front oversized oil port Y = rear oversized oil port Proximity sensors, see section 18 R = front sensor S = rear sensor Rod treatment, see section 9 K = nickel and chrome plating T = induction surface hardening and chrome plating Air bleeds, see section 16 A = front air bleed W = rear air bleed Draining, see section 17 L = rod side draining
Bore size , see section 3 from 63 to 200 mm																					Sealing system , see section 14 1 = (NBR + POLYURETHANE) high static and dynamic sealing 2 = (FKM + PTFE) very low friction and high temperatures 4 = (NBR + PTFE) very low friction and high speeds 6 = (NBR + PTFE) very low friction, single acting - pushing 7 = (NBR + PTFE) very low friction, single acting - pulling 8 = (NBR + PTFE and POLYURETHANE) low friction
Rod diameter , see sections 7 and 9 from 28 to 140 mm																					Spacer , see section 6 0 = none 2 = 50 mm 4 = 100 mm 6 = 150 mm 8 = 200 mm
Second rod diameter for double rod, see section 10 from 28 to 140 mm, omit for single rod																					Cushioning , see section 12 0 = none Fast adjustable 1 = rear only 2 = front only 3 = front and rear Slow adjustable 4 = rear only 5 = front only 6 = front and rear Fast fixed 7 = rear only 8 = front only 9 = front and rear
Stroke , see section 5 up to 5000 mm																					
Mounting style , see sections 2 and 3																					REF. ISO MP3 (3) MS2 MT1 MT2 (3) ME5 ME6 (3) MP5 (3) -

(1) For spare parts request indicate the series number printed on the nameplate only for series < 30
(2) To be entered in alphabetical order (3) Not available for double rod

2 MOUNTING STYLE - for dimensions see section **3**

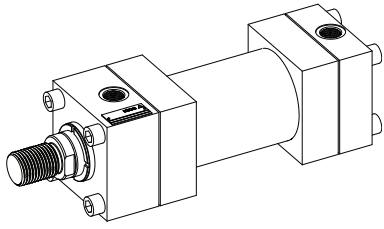

X = basic mounting

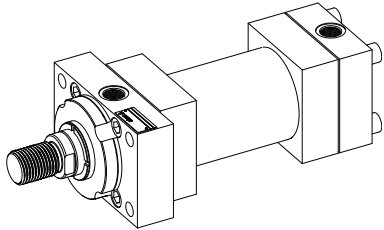
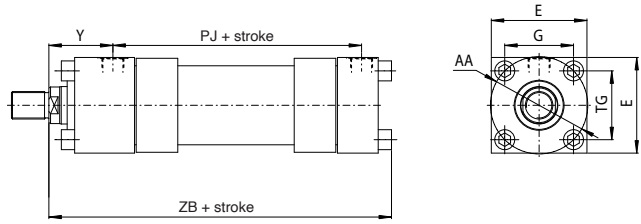

N (ISO ME5) = front flange mounting

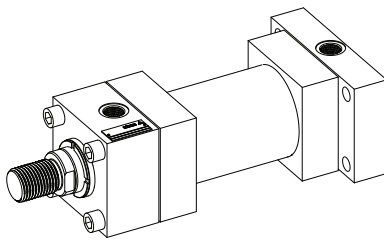
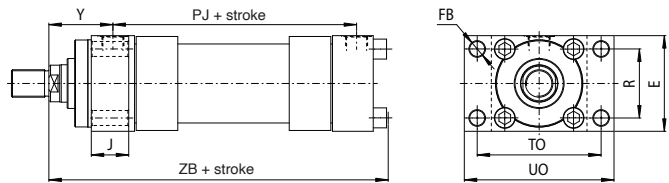

P (ISO ME6) = rear flange mounting

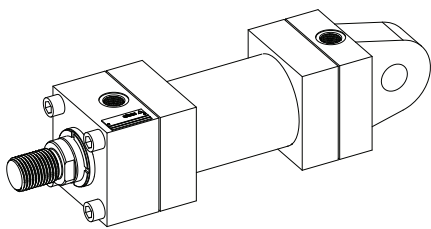
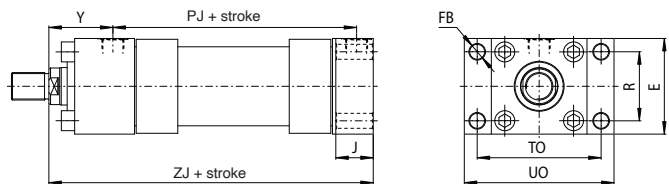

D (ISO MP3) = fixed eye mounting

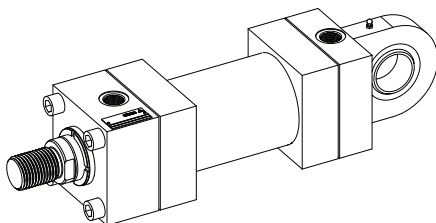
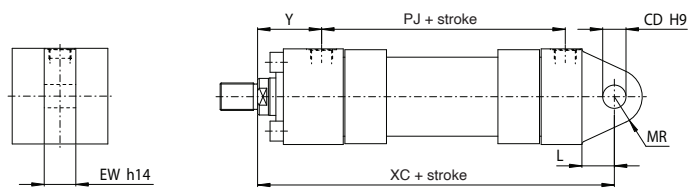

S (ISO MP5) = fixed eye with spherical bearing mounting

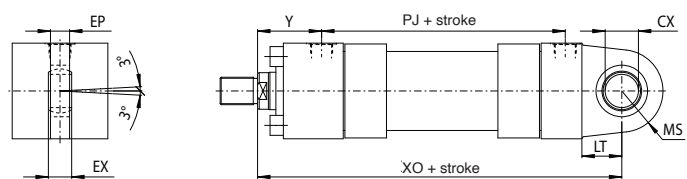

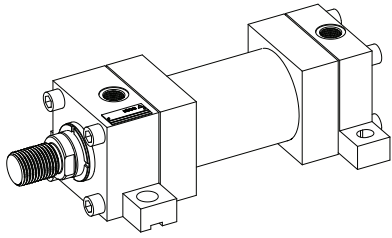

E (ISO MS2) = side feet mounting

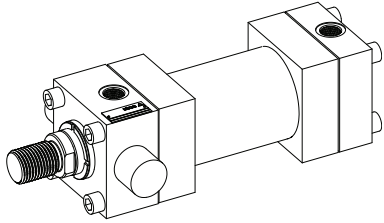
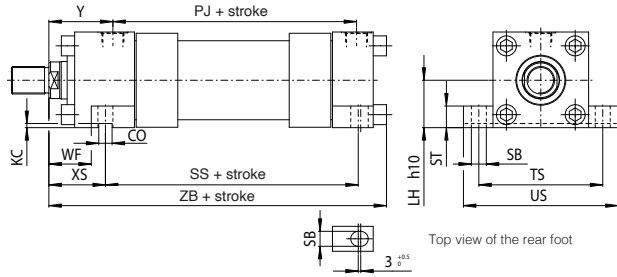

G (ISO MT1) = front trunnion mounting

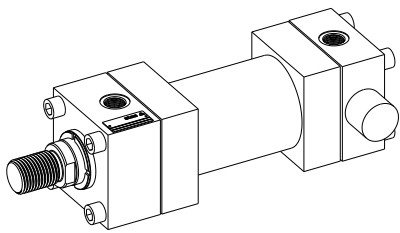
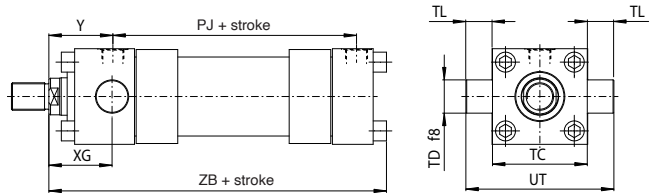

H (ISO MT2) = rear trunnion mounting

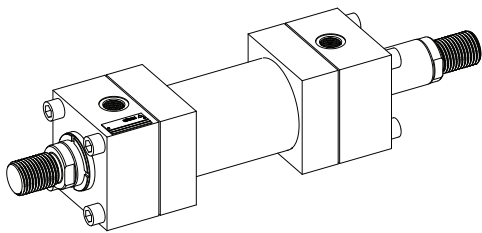
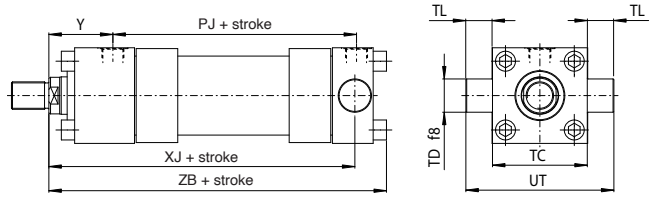

X = basic mounting for double rod

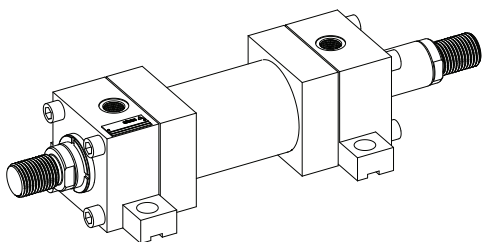
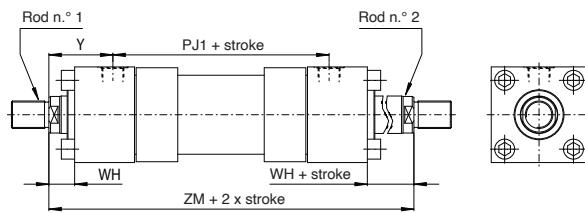

E = feet mounting for double rod

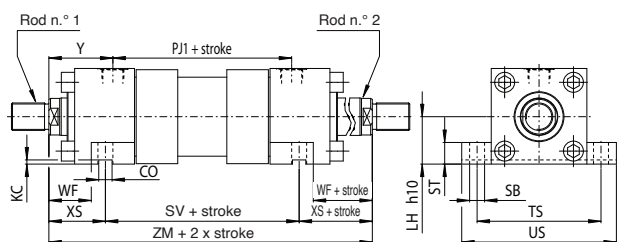

3 INSTALLATION DIMENSION [mm] - see figures in section [2]

Ø Bore		63	80	100	125	160	200
Ø Rod	standard	28	36	45	56	70	90
	intermediate	36	45	56	70	90	110
	differential	45	56	70	90	110	140
AA		91	117	137	178	219	269
CD H9		20	28	36	45	56	70
CO N9		16	16	16	20	30	40
CX	value	30	40	50	60	80	100
	tolerance	0 -0,012			0 -0,015		0 -0,02
E (1)		90±1,5	115±1,5	130±2	165±2	205±2	245±2
EP max		19	23	30	38	47	57
EW h14		30	40	50	60	70	80
EX		22 0/-0,12	28 0/-0,12	35 0/-0,12	44 0/-0,15	55 0/-0,15	70 0/-0,2
FB H13		14	18	18	22	26	33
J ref		38	45	45	58	58	76
L min		32	39	54	57	63	82
LH h10		44	57	63	82	101	122
LT min		38	48	58	72	92	116
KC min		4,5	5	6	6	8	8
MR max		29	34	50	53	59	78
MS max		40	50	62	80	100	120
PJ (2) ±1,5 (3)		80	93	101	117	130	165
PJ1 ±1,5 (3)		81	92	101	117	130	160
PJ2 (2) ±1,5 (3)		80	93	99	121	143	167
R js13		65	83	97	126	155	190
SB H13		18	18	26	26	33	39
SS ±1,25 (3)		85	104	101	130	129	171
ST js13		26	26	32	32	38	44
SV ±1,25 (3)		93	110	107	131	130	172
TC h14		89	114	127	165	203	241
TD f8		32	40	50	63	80	100
TG js13		64,3	82,7	96,9	125,9	154,9	190,2
TL js13		25	32	40	50	63	80
TO js13		117	149	162	208	253	300
TS js13		124	149	172	210	260	311
UO max		145	180	200	250	300	360
US max		161	186	216	254	318	381
UT ref		139	178	207	265	329	401
XC ±1,5 (3)		200	229	257	289	308	381
XG ±2 (3)		70	76	71	75	75	85
XJ ±1,5 (3)		149	168	187	209	230	276
XO ±1,5 (3)		206	238	261	304	337	415
XS ±2 (3)		65	68	79	79	86	92
Y (2) ±2 (3)		71	77	82	86	86	98
Y1 (2) ±2 (3)		70	75,5	83	84	79,5	97
ZB max		185	212	225	260	279	336
ZJ ±1 (3)		168	190	203	232	245	299
ZM ±2 (3)		223	246	265	289	302	+

NOTES TO TABLE [3]

(1) E - If not otherwise specified in the figures in section [2] this value is the front and rear square heads dimension for all the mounting styles (see figure below)

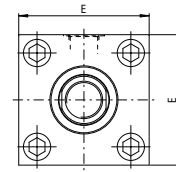

(2) When oversized oil ports are selected (see section [11] and [13] for dimensions and positions) dimensions PJ and Y are respectively modified into PJ2 and Y1

(3) The tolerance is valid for strokes up to 1250 mm, for longer strokes the upper tolerance is given by the max stroke tolerance in section [5]

4 SCREWS TIGHTENING TORQUES

Mounting screws must be to a minimum strength of ISO 898/2 grade 12.9.

Ø Bore	63	80	100	125	160	200
MT [Nm]	70	160	160	460	820	1160
Screw	M12	M16	M16	M22	M27	M30

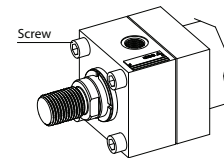

5 STROKE SELECTION

Stroke has to be selected a few mm longer than the working stroke, to prevent to use the cylinder heads as mechanical stroke-end. The table below shows the minimum stroke depending to the bore.

Minimum stroke [mm]

Ø Bore	63	80	100	125	160	200
Minimum stroke	55	70	70	75	70	85

Maximum stroke:

- 5000 mm

Stroke tolerances:

- 0 +2 mm for strokes up to 1250 mm
- 0 +5 mm for strokes from 1250 to 3150 mm
- 0 +8 mm for strokes over 3150 mm

6 SPACER

For strokes longer than 1000 mm, proper spacers have to be introduced in the cylinder's construction to increase the rod and piston guide and to protect them from overloads and premature wear. Spacers can be omitted for cylinders working in traction mode. The introduction of spacers increases the overall cylinder's dimensions: spacers' length has to be added to all stroke dependent dimensions in section [3].

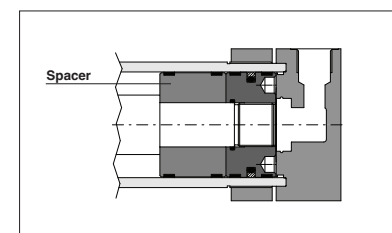

RECOMMENDED SPACERS [mm]

Stroke	1001 ÷ 1500	1501 ÷ 2000	2001 ÷ 2500	2501 ÷ 5000
Spacer code	2	4	6	8
Length	50	100	150	200

7 ROD END DIMENSIONS [mm]

Ø Bore	Ø Rod	Male thread		Female thread		A (KK or KF) (1)	A1 (KK1 or KF1) (1)	B f9	CH h14	F max	RD f8	VD	VE max	VL min	WF ±2	WH ±2	WL min
		KK	KK1 (option H)	KF	KF1 (option G)												
		6g	6g	6H	6H												
63	28	M20x1,5	NA	M20x1,5	NA	28	NA	42	22	16	75	13	29	4	48	32	7
	36	M27x2	M20x1,5	M27x2	NA	36	NA	50	30	16	88	13	29	4	48	32	8
	45	M33x2	M20x1,5	M33x2	M20x1,5	45	28	60	39	16	88	13	29	4	48	32	10
80	36	M27x2	NA	M27x2	NA	36	NA	50	30	20	82	9	29	4	51	31	8
	45	M33x2	M27x2	M33x2	NA	45	NA	60	39	20	105	9	29	4	51	31	10
	56	M42x2	M27x2	M42x2	M27x2	56	36	72	48	20	105	9	29	4	51	31	10
100	45	M33x2	NA	M33x2	NA	45	NA	60	39	22	92	10	32	5	57	35	10
	56	M42x2	M33x2	M42x2	NA	56	NA	72	48	22	125	10	32	5	57	35	10
	70	M48x2	M33x2	M48x2	M33x2	63	45	88	62	22	125	10	32	5	57	35	10
125	56	M42x2	NA	M42x2	NA	56	NA	72	48	22	105	10	32	5	57	35	10
	70	M48x2	M42x2	M48x2	NA	63	NA	88	62	22	150	7	29	5	57	35	10
	90	M64x3	M42x2	M64x3	M42x2	85	56	108	80	22	150	7	29	5	57	35	15
160	70	M48x2	NA	M48x2	NA	63	NA	88	62	25	125	7	32	5	57	32	10
	90	M64x3	M48x2	M64x3	NA	85	NA	108	80	25	170	7	32	5	57	32	15
	110	M80x3	M48x2	M80x3	M48x2	95	63	133	100	25	170	7	32	5	57	32	15
200	90	M64x3	NA	M64x3	NA	85	NA	108	80	25	150	7	32	5	57	32	15
	110	M80x3	M64x3	M80x3	NA	95	NA	133	100	25	210	7	32	5	57	32	15
	140	M100x3	M64x3	M100x3	M64x3	112	85	163	128	25	210	7	32	5	57	32	15

Notes: (1) Dimensions **A** and **A1** are according to ISO 4395 short type.
Tolerances: max for male thread; min for female thread

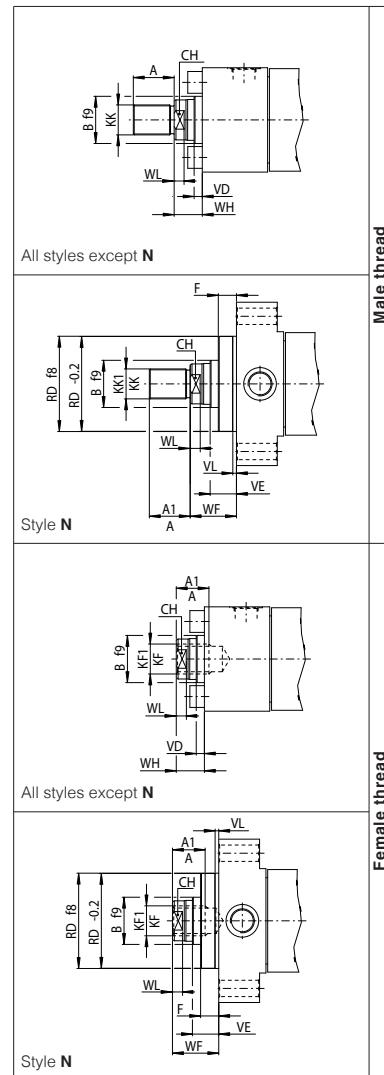

8 CYLINDER'S HOUSING FEATURES

The cylinder's housings are made in "cold drawn and stressed steel"; the internal surfaces are lapped; diameter tolerance H8, roughness Ra ≤ 0,25 µm.

9 RODS FEATURES and options

The rods materials have high strength, which provide safety coefficients higher than 4 in static stress conditions, at maximum working pressure. The rod surface is chrome plated: diameter tolerance f7, roughness Ra ≤ 0,25 µm. Corrosion resistance of 200h in neutral spray to ISO 9227 NSS.

ø Rod	Material	Rs min [N/mm ²]	Chrome	
			min thickness [mm]	hardness [HV]
28÷90	hardened and tempered alloy-steel	700	0,020	850-1150
110÷140	alloy steel	450		

Rod diameters from 28 to 70 mm have rolled threads; in rolling process the component material is stressed beyond its yield point, being deformed plastically. This offers many technical advantages: higher profile accuracy, improved fatigue working life and high wear resistance. See **tab. B015** for the calculation of the expected rod fatigue life. The rod and piston are mechanically coupled by a threaded connection in which the thread on the rod is at least equal to the external thread KK, indicated in the table [7]. The piston is screwed to the rod by a prefixed tightening torque in order to improve the fatigue resistance. The stop pin ① avoids the piston unscrewing. **Contact our technical office** in case of heavy duty applications.

Rod corrosion resistance and hardness can be improved selecting the options **K** and **T** (option K affects the strength of standard rod, see **tab. B015** for the calculation of the expected rod fatigue life):
K = Nickel and chrome-plating (for rods up to 110 mm)
Corrosion resistance (rating 10 to ISO 10289):

- 500 h in acetic acid salt spray to ISO 9227 AASS
- 1000 h in neutral spray to ISO 9227 NSS
- T** = Induction surface hardening and chrome plating
- 56-60 HRC (613-697 HV) hardness

10 DOUBLE ROD

Double rod cylinders ensure the same pushing and pulling areas, thus the same speeds and forces. Rod2 (see figure at side) is screwed into the male thread of Rod1, consequently the Rod2 is weaker than the other and it is strongly recommended to use this one only to compensate the areas; the stronger rod is identified by the number '1' stamped on its end. For double rod cylinders, rod end dimensions indicated in section [7] are valid for both the rods.

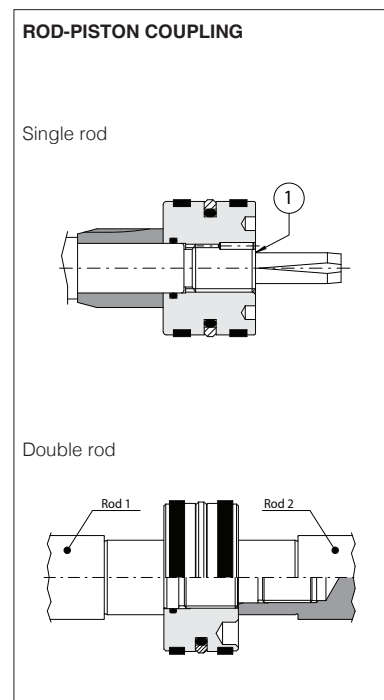

11 OIL PORTS AND ROD SPEEDS

The fluid speed in pipings connected to the cylinder oil ports should not exceed 6 m/s in order to minimize the turbulence flow, the pressure drop and water hammer. The table below shows the max recommended rod speed relative to 6 m/s flow velocity.

In high dynamic systems the rod can reach even higher speeds (after a careful check of dampable masses, see tab. B015): in these cases it is recommended to use piping's diameters larger than the cylinder oil ports and to introduce proper reductions just near the cylinder oil ports.

Ø Bore	Standard oil ports				Oversized oil ports D, Y options			
	D [mm]	EE 6g	Internal pipe Ø[mm] min	Rod speed V [m/s]	D [mm]	EE 6g	Internal pipe Ø[mm] min	Rod speed V [m/s]
63	29	G 1/2	14	0,30	36	G 3/4	16	0,39
80	36	G 3/4	16	0,18	42	G 1	20	0,37
100	36	G 3/4	16	0,15	42	G 1	20	0,24
125	42	G 1	20	0,15	52	G 1 1/4	30	0,34
160	42	G 1	20	0,09	52 (1)	G 1 1/4	30	0,21
200	52	G 1 1/4	30	0,13	58	G 1 1/2	40	0,24

Oil ports features are threaded according to ISO 1179-1 (GAS standards) with counter-bore dimension D type N (narrow).

Oil ports with SAE 3000 flanges are available on request, **contact our technical office.**

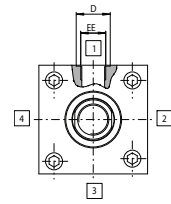

Note to table:

(1) For mounting styles D, E, N, P, S the dimension **PJ2** reported in section 3 is modified, contact our technical office.

12 CUSHIONING

Cushioning are recommended for applications where: • the piston makes a full stroke with speed over than 0,05 m/s; • it is necessary to reduce undesirable noise and mechanical shocks; • vertical application with heavy loads. The stroke-end cushioning are hydraulic dampers specifically designed to dissipate the energy of the mass connected to the cylinder rod, by progressively increasing the pressure in the cushioning chamber and thus reducing the rod speed before the cylinder's mechanical stroke-end (see the graphics at side). Two types of cushioning are available depending to the rod speed V:

Slow version for $V \leq 0,5 \cdot V_{max}$

Fast version for $V > 0,5 \cdot V_{max}$

See the table below for V_{max} values and tab. B015 for the max damping energy.

When fast or slow adjustable versions are selected, the cylinder is provided with needle valve to optimize cushioning performances in different applications. The regulating screws are supplied fully screwed in (max cushioning effect).

In case of high masses and/or very high operating speeds it is recommended to back them off to optimize the cushioning effect. The adjustment screw has a special design to prevent unlocking and expulsion. The cushioning effect is highly ensured even in case of variation of the fluid viscosity.

Ø Bore	63		80		100		125		160		200	
	Ø Rod	28	36	45	45	56	56	70	70	90	90	110
Cushioning length [mm]	Lf front	28	27	27	29	35	27	28	25	34	34	49
	Lf rear	30	30	32	32	32	32	32	41	41	50	50
V_{max} [m/s]		0,8	0,8	0,8	0,6	0,6	0,6	0,6	0,5	0,5	0,5	0,5

Lf is the total cushioning length. When the stroke-end cushioning are used as safety devices, to mechanically preserve the cylinder and the system, it is advisable to select the cylinder's stroke longer than the operating one by an amount equal to the cushioning length Lf; in this way the cushioning effect does not influence the movement during the operating stroke.

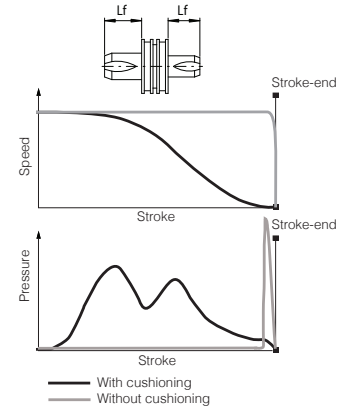

13 POSITION COMBINATION FOR OIL PORTS AND CUSHIONING ADJUSTMENTS

FRONT HEAD: **B*** = oil port position; **E*** = cushioning adjustment position REAR HEAD: **X*** = oil port position; **Z*** = cushioning adjustment position
The table below shows all the available configurations for the oil port and cushioning adjustment positions. Bolt characters identify the standard positions. Each configuration for the front head can be variously combined with any one of the rear head. Cushioning adjustment positions **E***, **Z*** have to be entered only if adjustable cushioning are selected.

Example of model code: CH-63/28 *0100-S301 - A - B2E3X1Z4

Mounting style	D, S												E		G		H		N, P			X										
	1	2	3	4	5	6	7	8	9	10	11	12	1	2	1	2	1	2	3	1	2	3										
FRONT HEAD	Oil port side												B	1	1	2	1	2	4	3	1	1	1	1	2	1	1	2	1	1	2	3
	Cushioning adjustment side												E	3	2	3	4	4	3	1	2	4	3	3	4	3	2	3	3	4	3	1
REAR HEAD	Oil port side												X	1	1	2	1	2	4	3	1	1	1	2	1	1	1	2	1	1	2	3
	Cushioning adjustment side												Z	3	2	3	4	4	3	1	2	4	3	4	3	3	2	3	3	4	3	1

• Dimensions **PJ, PJ2, Y** and **Y1** change compared to the values in section 3, contact our technical office

(a) Front view rod side (rod n°1 for double rods)

Contact our technical office for combinations not included in the table.

14 SEALING SYSTEM FEATURES

The sealing system must be chosen according to the working conditions of the system: speed, operating frequencies, fluid type and temperature. Additional verifications about minimum in/out rod speed ratio, static and dynamic sealing friction are warmly suggested, see tab. B015.

When single acting seals are selected (types 6 and 7), the not pressurized cylinder's chamber must be connected to the tank. Special sealing system for low temperatures, high frequencies (up to 20 Hz), long working life and heavy duty are available, see tab. TB020. All the seals, static and dynamic, must be periodically replaced: proper spare kits are available, see section 23. Contact our technical office for the compatibility with other fluids not mentioned below and specify type and composition. See section 20 for fluid requirements.

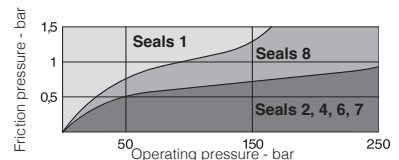

Sealing system	Material	Features	Max speed [m/s]	Fluid temperature range	Fluids compatibility	ISO Standards for seals	
						Piston	Rod
1	NBR + POLYURETHANE	high static and dynamic sealing	0,5	-20°C to 85°C	Mineral oils HH, HL, HLP, HLP-D, HM, HV, MIL-H-5606	ISO 7425/1	ISO 5597/1
2	FKM + PTFE	very low friction and high temperatures	4	-20°C to 120°C	Mineral oils HH, HL, HLP, HLP-D, HM, HV, MIL-H-5606 fire resistance fluids HFA, HFB, HFC (water max 45%), HFD-U, HFD-R	ISO 7425/1	ISO 7425/2
4	NBR + PTFE	very low friction and high speeds	4	-20°C to 85°C	Mineral oils HH, HL, HLP, HLP-D, HM, HV, MIL-H-5606 fire resistance fluids HFA, HFC (water max 45%), HFD-U	ISO 7425/1	ISO 7425/2
6 - 7	NBR + PTFE	very low friction single acting - pushing/pulling	1	-20°C to 85°C	Mineral oils HH, HL, HLP, HLP-D, HM, HV, MIL-H-5606 fire resistance fluids HFA, HFC (water max 45%), HFD-U	ISO 7425/1	ISO 7425/2
8	PTFE + NBR + POLYURETHANE	low friction	0,5	-20°C to 85°C	Mineral oils HH, HL, HLP, HLP-D, HM, HV, MIL-H-5606	ISO 7425/1	ISO 7425/2

15 INCORPORATED SUBPLATE

CH cylinders with oil ports positions 1 can be supplied with ISO (size 06, 10, 16 and 25) incorporated subplates for mounting of valves directly on the cylinder.

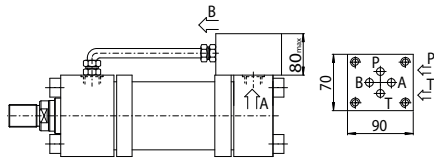

10 = subplate with mounting surface 4401-03-02-0-05 (size 06)
Oil ports P and T = G 3/8
For bores from 63 to 200 and strokes longer than 100 mm
For shorter strokes, the cylinder must be provided with suitable spacer

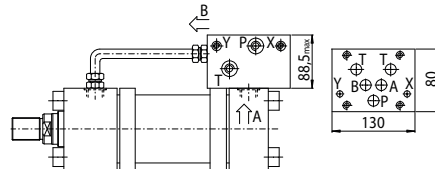

20 = subplate with mounting surface 4401-05-05-0-05 (size 10)
Oil ports P and T = G 3/4; X and Y = G 1/4
For bores from 63 to 200 and strokes longer than 150 mm
For shorter strokes, the cylinder must be provided with suitable spacer

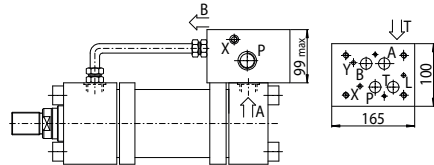

30 = subplate with mounting surface 4401-07-07-0-05 (size 16)
Oil ports P and T = G 1; L, X and Y = G 1/4
For bores from 80 to 200 and strokes longer than 150 mm
For shorter strokes, the cylinder must be provided with suitable spacer

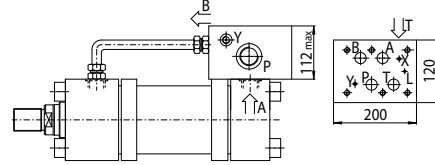

40 = subplate with mounting surface 4401-08-08-0-05 (size 25)
Oil ports P and T = G 1; L, X and Y = G 1/4
For bores from 125 to 200 and strokes longer than 150 mm
For shorter strokes, the cylinder must be provided with suitable spacer

Note: for the choice of suitable spacer see section 16. The addition of spacer length and working stroke must be at least equal or upper than the minimum stroke indicated above, see the following example:

Subplate **20**; working stroke = **70** mm; min. stroke = **150** mm → select spacer **4** (length = **100** mm)

16 AIR BLEEDS

CODES: **A** = front air bleed; **W** = rear air bleed

The air in the hydraulic circuit must be removed to avoid noise, vibrations and irregular cylinder's motion: air bleed valves are recommended to realize this operation easily and safely. Air bleeds are usually positioned on the opposite side of the oil port except for front heads of mounting styles **N, G** (on side 3), rear heads of mounting styles **D, S, H, P** (on side 3) and for heads of mounting style **E** (on side 2), see section 13. For cylinders with adjustable cushioning the air bleeds are positioned on the same side of the cushioning adjustment screw. For Servocylinders, cylinders with incorporated subplates or proximity sensors, air bleeds are supplied as standard and they must not be entered in the model code. For cylinders with proximity sensors, air bleeds A, W or AW are supplied respectively depending on the selected sensors R, S or RS. For a proper use of the air-bleed (see figure on side) unlock the grub screw ① with a wrench for hexagonal head screws, bleed-off the air and retighten as indicated in table at side.

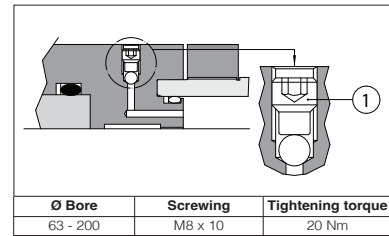

17 DRAINING

CODE: **L** = rod side draining

The rod side draining reduces the seals friction and increases their reliability; it is mandatory for cylinders with strokes longer than 2000 mm, with rod side chamber constantly pressurized and for servocylinder.

The draining is positioned on the same side of the oil port, between the wiper and the rod seals (see figure at side) and it can be supplied only with sealing system: **1, 2, 4, 7** and **8**. It is recommended to connect the draining port to the tank without backpressure. Draining port is G1/8.

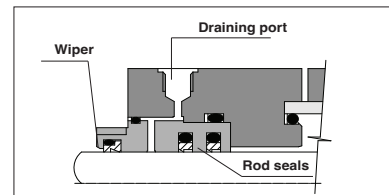

18 PROXIMITY SENSORS

CODES: **R** = front sensor; **S** = rear sensor

Proximity sensors functioning is based on the variation of the magnetic field, generated by the sensor itself, when the cushioning piston enters on its influence area, causing a change of state (on/off) of the sensors. The distance from the mechanical stroke-end of the cylinder, at which occurs the switching of the sensor's electrical contact, can be adjusted between 1 and 3 mm. For their regulation, it is necessary to position the rod where it is desired to obtain the contact switching and rotate the sensor until its LED switch-on (commutation occurred). The sensors tightening torque must be lower than 40 N/m to avoid damages. The sensors must always be coupled with fast adjustable cushioning, see section 12, to avoid pressure peaks on stroke-end. They are positioned on side 4 and they can be coupled with the standard oil ports and cushioning adjustments positions in bolt characters, see section 13. The coupling of the proximity sensors with the stroke-end cushioning imposes particular executions with limitation of the damping masses and/or speeds compared to the executions with standard cushioning.

Limitations

R option not available for G and N mounting styles; **S** option not available for P and H mounting styles.

Ø Bore	63	80	100	125	160	200
DB max	71	71	71	68	68	63
DC	62	67	62	64	63	63

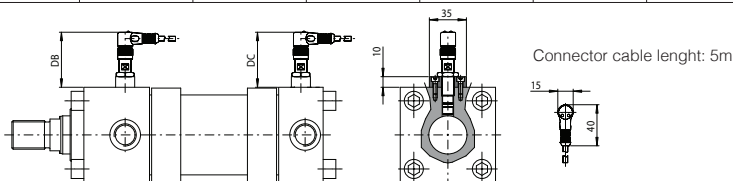

SENSORS TECHNICAL DATA

The proximity sensors are inductive type, they supply a "NO" (Normally Open) output signal which status corresponds to the rod position:

- **R, S** = close contact = 24 Volt at output contacts = rod positioned at stroke ends
- **R, S** = open contact = 0 Volt at output contacts = rod not positioned at stroke ends

Ambient temperature	-20 +70°C
Nominal voltage	24 VDC
Operating voltage	10...30 VDC
Max load	200 mA
Version	PNP
Output type	NO
Repeatability	<5%
Hysteresis	<15%
Protection	IP68
Max pressure	25 MPa (250 bar)

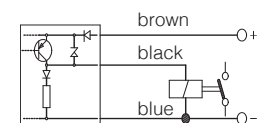

19 SIL compliance with IEC 61508: 2010

CH meets the requirements of:

- **SC3** (systematic capability)
- max **SIL 2** (HFT = 0 if the hydraulic system does not provide the redundancy for the specific safety function where the component is applied)
- max **SIL 3** (HFT = 1 if the hydraulic system provides the redundancy for the specific safety function where the component is applied)

20 FLUID REQUIREMENTS

Cylinders and servocylinders are suitable for operation with mineral oils with or without additives (**HH, HL, HLP, HLP-D, HM, HV**), fire resistant fluids (**HFA** oil in water emulsion, 90-95% water and 5-10% oil; **HFB** water in oil emulsion, 40% water; **HFC** water glycol, max 45% water) and synthetic fluids (**HFD-U** organic esters, **HFD-R** phosphate esters). The fluid must have a viscosity within 15 and 100 mm²/s, a temperature within 0 and 70°C and fluid

21 CYLINDERS MASSES [kg] (tolerance ± 5%)

Ø Bore [mm]	Ø Rod [mm]	MASS FOR STYLES X, Z Single rod		MASS FOR STYLES X, Z Double rod		ADDITIONAL MASSES according to mounting styles and options							
		Stroke 100 mm	Each added 100 mm	Stroke 100 mm	Each added 100 mm	Style D	Style E	Style G	Style N	Style P	Style S	Each cushioning	Each 50 mm spacer
63	28	9,65	1,54	12,03	2,03	0,41	1,54	0,26	1,34	1,34	0,46	0,25	1,68
	36	10,17	1,85	12,98	2,65								
	45	10,84	2,31	14,68	3,56								
80	36	19,24	2,82	22,69	3,62	0,79	1,23	1,63	2,39	2,39	0,86	0,40	2,85
	45	20,00	3,32	24,21	4,57								
	56	20,34	3,95	26,14	5,88								
100	45	25,89	3,76	31,94	5,01	2,31	1,63	1,00	2,94	2,94	1,77	0,60	4,15
	56	26,79	4,46	34,10	6,39								
	70	28,09	5,54	37,29	8,56								
125	56	48,38	5,88	58,38	7,81	2,87	4,60	1,50	5,65	5,65	4,65	1,15	6,61
	70	50,02	6,98	63,33	10,00								
	90	54,40	8,94	77,66	13,93								
160	70	80,74	8,34	92,15	11,36	7,63	7,56	4,66	7,97	7,97	8,21	1,85	10,75
	90	85,50	10,31	102,27	15,31								
	110	90,09	12,77	112,39	20,23								
200	90	135,62	12,00	148,54	17,00	13,82	14,60	9,86	16,78	16,82	14,80	2,50	15,86
	110	142,41	14,01	154,67	21,47								
	140	149,21	18,63	160,80	30,72								

Note: the masses related to the other options, not indicated in the table, don't have a relevant influence on the cylinder's mass

22 CYLINDER SECTION

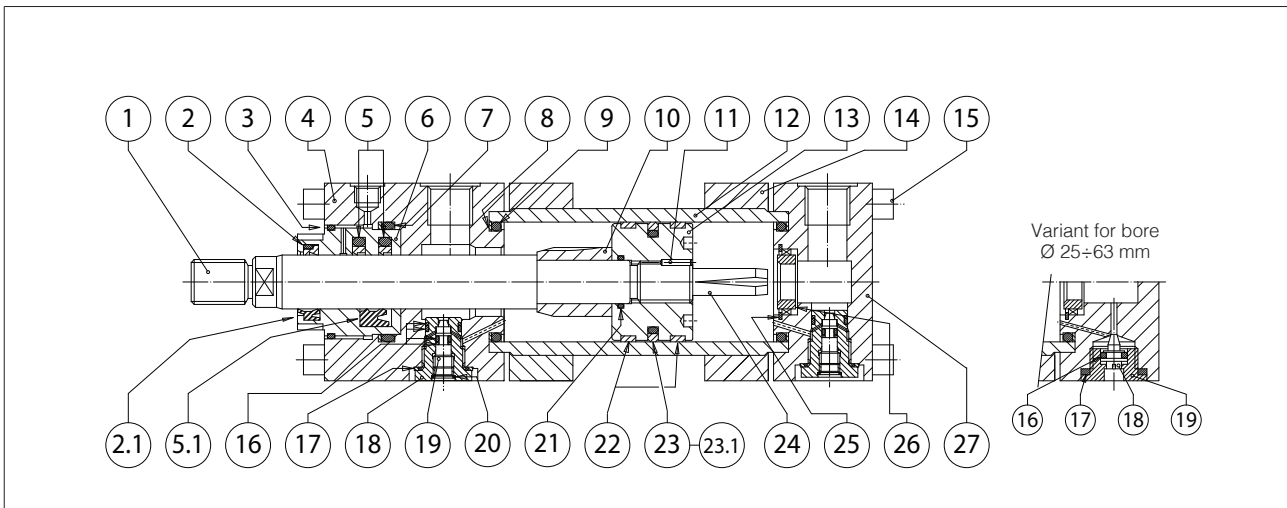

PART	DESCRIPTION	MATERIAL	PART	DESCRIPTION	MATERIAL	PART	DESCRIPTION	MATERIAL
1	Rod	Chromeplated steel	9	O-ring	NBR / FKM	19	Cushioning adjustment screw	Steel
2	Wiper	NBR / FKM and PTFE	10	Front cushioning piston	Steel	20	Seeger	Steel
2.1	Wiper (G1)	Polyurethane	11	Screw stop pin	Steel	21	O-ring	NBR / FKM
3	O-ring	NBR / FKM	12	Cylinder housing	Steel	22	Piston guide ring	PTFE or phenolic resin
4	Front head	Steel / Cast iron	13	Piston	Steel	23	Piston seal	NBR / FKM and PTFE
5	Rod seal	NBR / FKM and PTFE	14	Counterflange	Steel	23.1	Piston seal (G1)	NBR and polyurethane
5.1	Rod seal (type G1)	Polyurethane	15	Screw	Steel (grade12.9)	24	Rear cushioning piston	Steel
6	Rod bearing	Bronze	16	O-ring and anti-extrusion ring	FKM and PTFE	25	Toroidal ring	Steel
7	O-ring and anti-extrusion ring	NBR / FKM and PTFE	17	Seal	FKM	26	Rear cushioning sleeve	Bronze
8	Anti-extrusion ring	PTFE	18	Cushioning adjustment plug	Steel	27	Rear head	Steel / Cast iron

23 SPARE PARTS - SEE TABLE SP-B140

Example for seals spare parts code

G 8	-	C K	-	63	/	28	/	28
Sealing system		Cylinder series		Bore size [mm]		Rod diameter [mm]		Second rod diameter for double rod [mm] Omit if not requested