

Radial piston pumps type PFR

fixed displacement

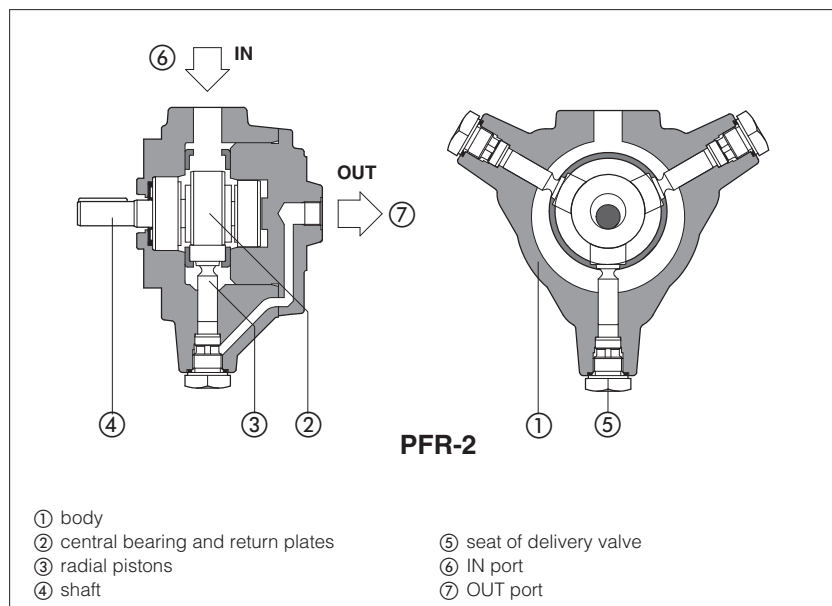

PFR are fixed displacement radial piston pumps with positive drive construction of the pistons ③ (without return spring) for high performance and low noise level.

They are available in three different body size and single, multiple or with through-shaft configurations.

Max displacement **up to 14,7 cm³/rev.**

Max pressure **PFR-2 500 bar**
PFR-3 350 bar

1 MODEL CODE

PFR	XA	-	3	08	**	-	*
Fixed displacement radial piston pump					Series number		Seals material: - = NBR PE = FKM
Option for pumps with through shaft, see section 3 Only for PFR-3: XA, XA7, XB, XB7, XC = for coupling with pumps type PFE				Displacement [cm³/rev], see section 2 for PFR-2: 02, 03 for PFR-3: 08, 11, 15			
				Size, see section 2: 2, 3			

Note: for multiple pumps factory assembled, see tech. table A190

2 HYDRAULIC CHARACTERISTICS - based on mineral oil ISO VG 46 at 50 °C

Size code	2		3		
	02	03	08	11	15
Displacement code					
Displacement (cm ³ /rev)	1,7	3,5	8,2	11,4	14,7
Max working pressure (1) (bar)	500		350		
Recommended pressure on inlet port	from -0,10 to 1,5 bar for speed up to 1800 rpm				
Min speed (rpm)	800				
Max speed (2) (rpm)	1800				
Volumetric efficiency (3)	98	97	97	98	98
Noise level (3) (dBA)	62	62	65	65	65

(1) Max pressure is 250 bar for HFDU, HFDR fluids - max pressure is 175 bar for HFC fluids

(2) Max speed is 1000 rpm for HFDU, HFDR and HFC fluids

(3) Measuring data with: n = 1450 rpm; P = 200 bar, see also diagram at section 4

3 OPTION FOR PUMPS WITH THROUGH SHAFT

Pump size	PFR-3				
Through shaft option type	XA	XB	XA7	XB7	XC
Splined coupling characteristics	SAE 16/32-9T	SAE 16/32-13T	SAE 16/32-13T	SAE 12/24-14T	SAE 12/24-14T
2 nd pump PFE to be coupled	PFE-3* shaft type 5	PFE-4* shaft type 5	PFE-3* shaft type 7	PFE-4* shaft type 7	PFE-5* shaft type 5

4 MAIN CHARACTERISTICS

Installation position	Any position. It is advisable to install on the outlet pipe a proper valve for air bleeding. The installation under oil level is recommended. The installation above oil level should be avoided. The shaft of the pump has an eccentric cam which rotates with the shaft generating the stroke of the pistons and thus generating the flow rate. For best functioning a balanced coupling should be provided between the shaft of the motor and the shaft of the pump. See section [1]
Commissioning	PFR pumps can be reversed without changing the flow direction. Therefore both directions of rotation are permitted. It is recommend to start the pump by short impulses, with pump case filled with working fluid and air bleed plugs unlocked. Pumps type PFR-3 have 2 air bleeds ports, normally plugged, located near to the P ports. To help oil filling and air bleeding, it could be advisable to install a vertical pipe connected on the intake line, just before the IN port flange.
Loads on the shaft	Axial and radial loads are not allowed on the shaft. The coupling should be sized to absorb the power peak.
Compliance	EACH Regulation (EC) n°1907/2006 RoHS Directive 2011/65/EU as last update by 2015/863/EU

5 SEALS AND HYDRAULIC FLUIDS - for other fluids not included in below table, consult our technical office

Seals, recommended fluid temperature	NBR seals (standard) = -25°C ÷ +60°C, with HFC hydraulic fluids = -20°C ÷ +50°C FKM seals (/PE option) = -20°C ÷ +80°C		
Recommended viscosity	10÷ 100 mm ² /s - max at cold start 800 mm ² /s		
Max fluid contamination level	normal operation	ISO4406 class 21/19/16 NAS1638 class 10	see also filter section at
	longer life	ISO4406 class 18/16/13 NAS1638 class 8	www.atos.com or KTF catalog
Hydraulic fluid	Suitable seals type	Classification	Ref. Standard
Mineral oils	NBR, FKM	HL, HLP, HLPD, HVLP, HVLPD	DIN 51524
Flame resistant without water	FKM	HFDR, HFDR (1)	ISO 12922
Flame resistant with water	NBR	HFC (1)	

(1) See performance restrictions at section [2]

6 DIAGRAMS (based on mineral oil ISO VG 46 at 50°C)

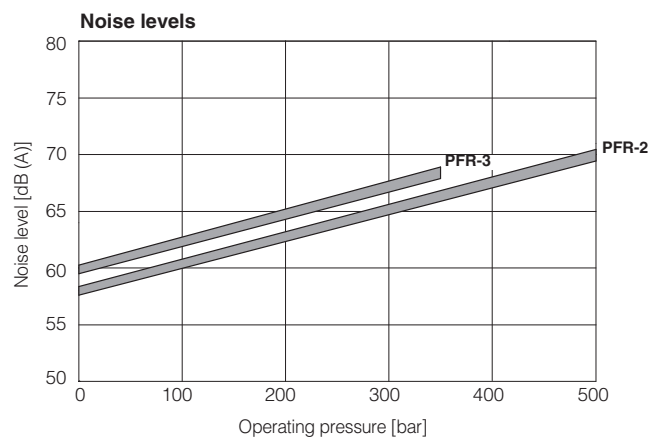
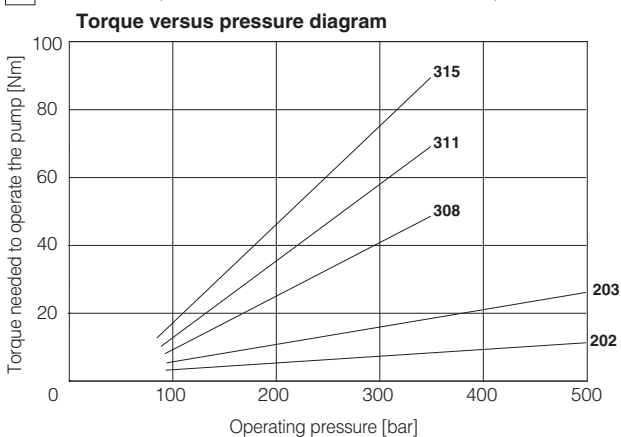

7 LIMIT OF SHAFT TORQUE

Pump size	Maximum driving torque [Nm]	Maximum torque available on the end of the through shaft [Nm]
PFR-2	200	-
PFR-3	600	320

The values of torque needed to operate the pumps are shown on the "torque versus pressure diagram" at section [6].

In multiple pumps the total torque applied to the shaft of the first element (drive shaft) is the sum of the single torque needed for operating each single pump and it is necessary to verify that this total torque applied to the drive shaft is not higher than the values indicated in the table.

8 DIMENSIONS OF SINGLE PUMPS [mm]

PFR-2

Mass: 12 Kg

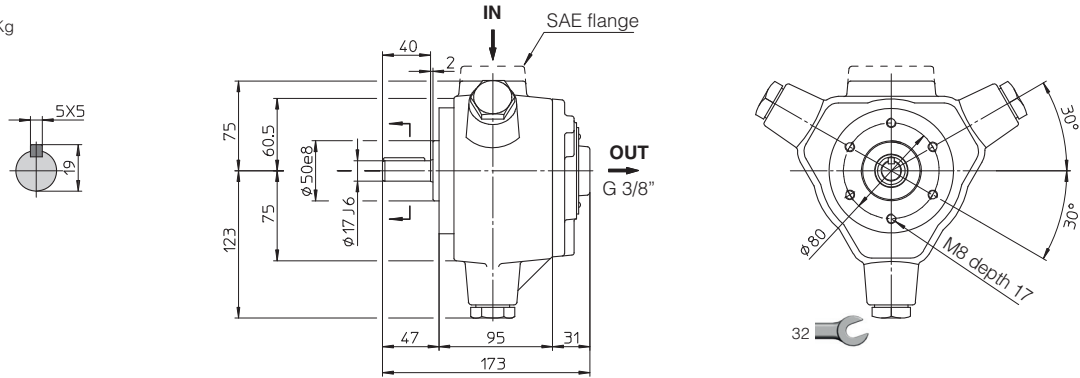

Note: PFR-206 have 5 pistons in the same size

PFR-3

Mass: 31 Kg

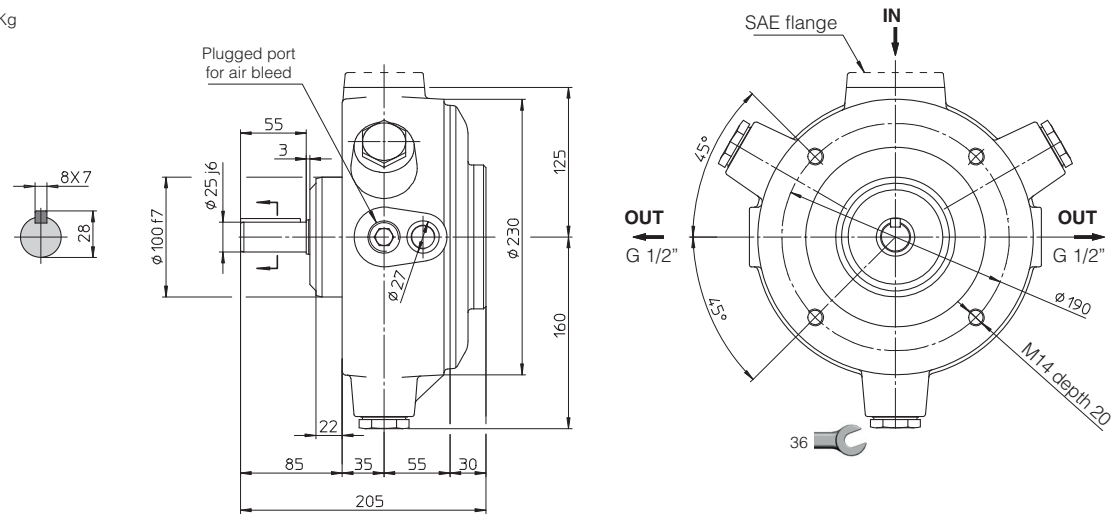

SAE flanges are supplied with the pump

9 SAE-3000 FLANGES supplied with the pump [mm]

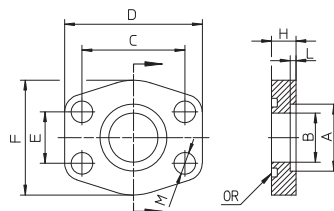

Flanges are supplied with seal and screws M10 class 12.9
Tightening torque = 70 Nm

Pump model	Flange code	A	B	C	D	E	F	H	L	M	OR	Screws
PFR - 2	WFA-25	35,5	29	52,37	70	26,19	55	12	4	$\phi 11$	4131	M10x30
PFR - 3	WFA-32	42,5	34	58,72	79	30,18	68	12	4	$\phi 11,5$	4150	M10x35

10 DIMENSIONS OF PUMPS WITH THROUGH-SHAFT (XA*, XB*, XC options) [mm]

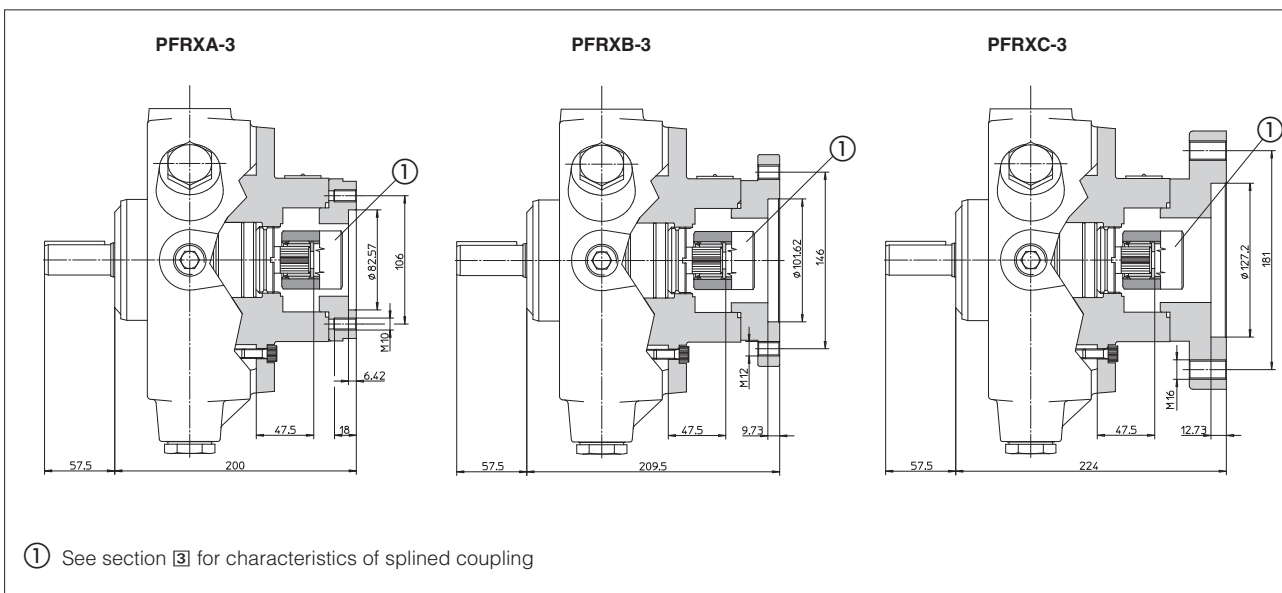

11 BALANCED COUPLING

The balanced couplings permit to minimize the vibrations caused by the unbalanced mass during the pump rotation. The couplings listed in the table, supplied by Atos, must be used together with the relevant bell housing. The table lists the codes of the Atos balanced couplings and bell housing, available for the several pumps and for the standardized sizes of the electrical motors.

PUMP MODEL	ELECTRICAL MOTOR	BALANCED COUPLING	BELL HOUSING
PFR-202	UNEL-MEC 100-112	Y-GB-82/02	Y-LS4P2
	UNEL-MEC 132	Y-GB-122/02	Y-LS6P2
PFR-203	UNEL-MEC 100-112	Y-GB-82/03	Y-LS4P2
	UNEL-MEC 132	Y-GB-122/03	Y-LS6P2
PFR-308	UNEL-MEC 100-112	Y-GB-83/08	Y-LS4P3
	UNEL-MEC 132	Y-GB-123/08	Y-LS6P3
	UNEL-MEC 160	Y-GB-303/08	Y-LS7P3
PFR-311	UNEL-MEC 100-112	Y-GB-83/11	Y-LS4P3
	UNEL-MEC 132	Y-GB-123/11	Y-LS6P3
	UNEL-MEC 160	Y-GB-303/11	Y-LS7P3
PFR-315	UNEL-MEC 100-112	Y-GB-83/15	Y-LS4P3
	UNEL-MEC 132	Y-GB-123/15	Y-LS6P3
	UNEL-MEC 160	Y-GB-303/15	Y-LS7P3

12 RELATED DOCUMENTATION

A900 Operating and maintenance information for pumps
