

Pressure relief valves type ARAM

two stage, in line mounting - G 3/4" and G 1 1/4" threaded ports

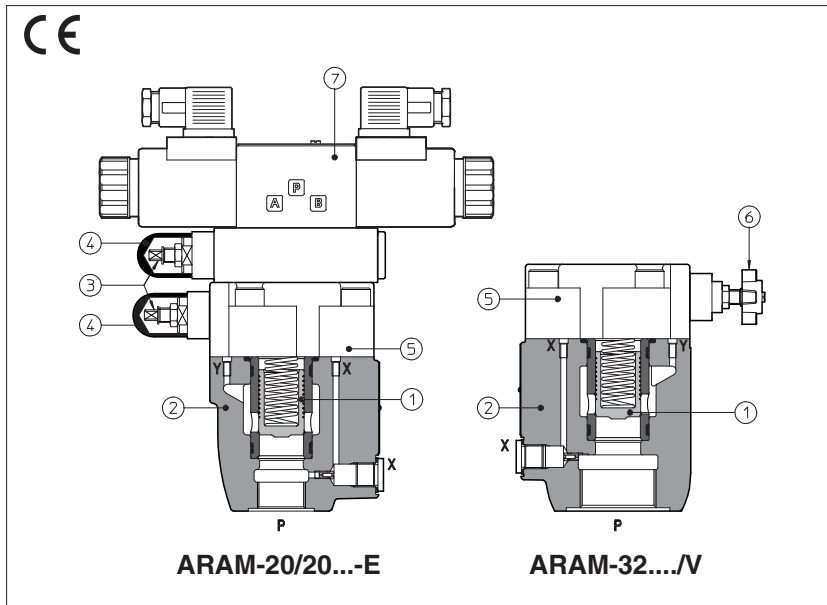

ARAM are two stage pressure relief valves with balanced poppet, designed with threaded ports for in-line mounting.

In standard versions the piloting pressure of the poppet ① of the main stage ② is regulated by means of a grub screw ③ protected by cap ④ installed in the cover ⑤.

Optional versions with setting adjustment by handwheel ⑥ instead of the grub screw are available on request. Clockwise rotation increases the pressure.

ARAM can be equipped with a pilot solenoid valve ⑦ for venting or for different pressure setting, type:

- DHE for AC and DC supply, high performances with **cURus** certified solenoids
- DHL for AC and DC supply, compact execution

Threaded ports: **G 3/4", G 1 1/4"**
 Max flow: **350, 500 l/min**
 Max pressure up to **350 bar**

1 MODEL CODE

ARAM	-	20	/	20	/	210	/	100/100	/	V	-	E	X	24DC	**	/	*
<p>ARAM = pressure relief valve threaded port connections</p> <p>Size: 20= port P - G 3/4" 32= port P - G 1 1/4"</p> <p>Setting pressure and venting option (1): - = one setting pressure without option 10= one setting pressure with venting, with de-energized solenoid 11= one setting pressure with venting, with energized solenoid 20= two setting pressure with venting, with de-energized solenoid 21= two setting pressure with venting, with energized solenoid 22= two setting pressure without venting 32= three setting pressure without venting</p> <p>Setting: see section 4 for available setting</p> <p>Pressure range of second/third setting (1): 50 = 4÷50 bar 100 = 6÷100 bar 210 = 7÷210 bar 350 = 8÷350 bar</p> <p>Options, see section 7 E V WP Y</p> <p>X = without connector (1): See section 10 for available connectors, to be ordered separately -00-AC = AC solenoid valve without coils -00-DC = DC solenoid valve without coils</p> <p>Pilot valve (1): E = DHE for AC and DC supply, high performances with cURus certified solenoids L = DHL for AC and DC supply, compact execution</p> <p>Seals material, see section 11: - = NBR PE = FKM BT = HNBR (2)</p> <p>Series number</p> <p>Voltage code, see section 6 (1):</p>																	

For **PED** version see technical table CY045

- (1) Only for ARAM with solenoid valve for venting and/or for the selection of the setting pressure.
- (2) Not available for -L version (DHL pilot valve)

2 HYDRAULIC SYMBOL

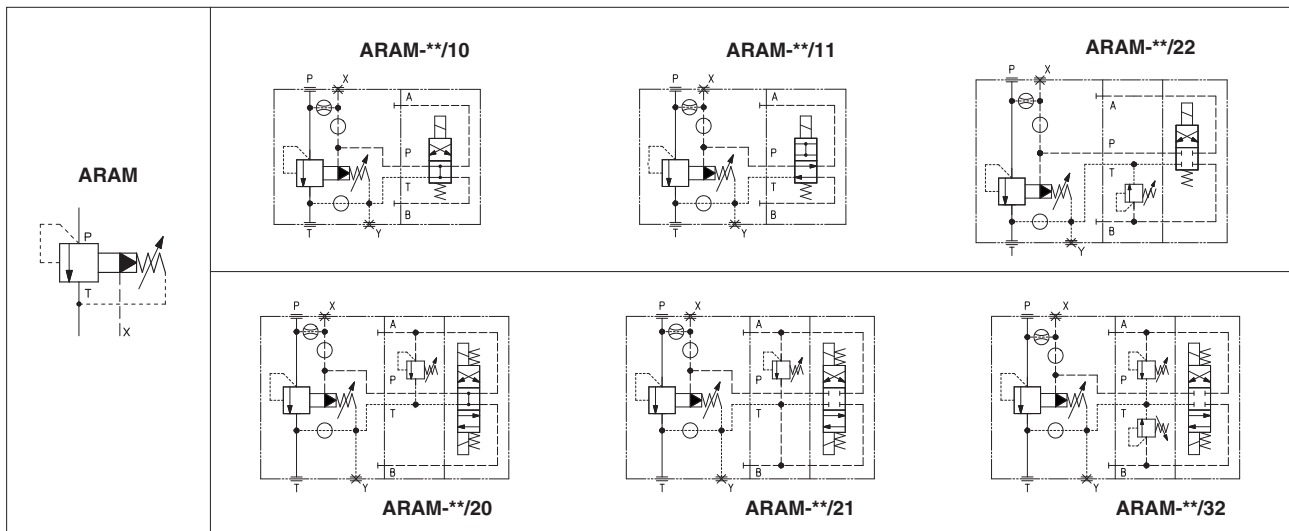

3 GENERAL CHARACTERISTICS

Assembly position	Any position
Subplate surface finishing to ISO 4401	Acceptable roughness index, $R_a \leq 0,8$ recommended $R_a 0,4$ - flatness ratio 0,01/100
MTTFd valves according to EN ISO 13849	75 years, see technical table P007
Ambient temperature range	Standard = $-30^\circ\text{C} \div +70^\circ\text{C}$ / PE option = $-20^\circ\text{C} \div +70^\circ\text{C}$ / BT option = $-40^\circ\text{C} \div +70^\circ\text{C}$
Storage temperature range	Standard = $-30^\circ\text{C} \div +80^\circ\text{C}$ / PE option = $-20^\circ\text{C} \div +80^\circ\text{C}$ / BT option = $-40^\circ\text{C} \div +80^\circ\text{C}$
Surface protection	Body: zinc coating with black passivation Coil: zinc nickel coating (DC version) plastic incapsulation (AC version)
Corrosion resistance	Salt spray test (EN ISO 9227) > 200 h
Compliance	CE to Low Voltage Directive 2014/35/EU RoHS Directive 2011/65/EU as last update by 2015/65/EU REACH Regulation (EC) n°1907/2006

4 HYDRAULIC CHARACTERISTICS

Valve model	ARAM-20		ARAM-32	
Setting [bar]	50;	100;	210;	350
Pressure range [bar]	4÷50;	6÷100;	7÷210;	8÷350
Max pressure [bar]	Ports P, X = 350 Ports T, Y = 210 (without pilot solenoid valve) For version with pilot solenoid valve, see technical tables E015 and E018			
Max flow [l/min]	350		500	

5 ELECTRICAL CHARACTERISTICS

Insulation class	H (180°C) for DC coils; F (155°C) for AC coils Due to the occurring surface temperatures of the solenoid coils, the European standards EN ISO 13732-1 and EN ISO 4413 must be taken into account
Protection degree to DIN EN 60529	IP 65 (with connectors correctly assembled)
Relative duty factor	100%
Supply voltage and frequency	See section 6
Supply voltage tolerance	$\pm 10\%$
Certification	cURus North American standard - only for DHE pilot valve

6 COIL VOLTAGE

External supply nominal voltage ± 10%	Voltage code	Type of connector	-EX Power consumption (2)	-LX Power consumption (2)	Code of spare coil -EX	Code of spare coil -LX
12 DC	12 DC	666 or 667	30W	29W	COE-12DC	COL-12DC
14 DC	14 DC				COE-14DC	COL-14DC
110 DC	110 DC				COE-110DC	COL-110DC
220 DC	220 DC				COE-220DC	COL-220DC
110/50 AC (1)	110/50/60 AC	666 or 667	58VA (3)	58VA (3)	COE-110/50/60AC	COL-110/50/60AC
115/60 AC	115/60 AC		80VA (3)		COE-115/60AC	COL-115/60AC
230/50 AC (1)	230/50/60 AC		58VA (3)		COE-230/50/60AC	COL-230/50/60AC
230/60 AC	230/60 AC		80VA (3)		COE-230/60AC	COL-230/60AC

(1) For other supply voltages available on request see technical tables E015, E018.

(2) Coil can be supplied also with 60 Hz of voltage frequency: in this case the performances are reduced by 10 ÷ 15% and the power consumption is 55 VA (DHL) and 58 VA (DHE)

(3) Average values based on tests performed at nominal hydraulic condition and ambient/coil temperature of 20°C.

(4) When solenoid is energized, the inrush current is approx 3 times the holding current.

7 OPTIONS

/E = external pilot

/V = regulating handwheel instead of grub screw protected by cap (for handwheel features, see table K150)

/WP = prolonged manual override protected by rubber cap (only for ARAM with pilot solenoid valve)

/Y = external drain (only for ARAM with pilot solenoid valve)

8 REGULATED PRESSURE VERSUS FLOW DIAGRAMS based on mineral oil ISO VG 46 at 50°C

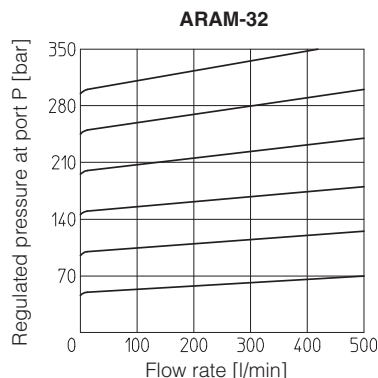
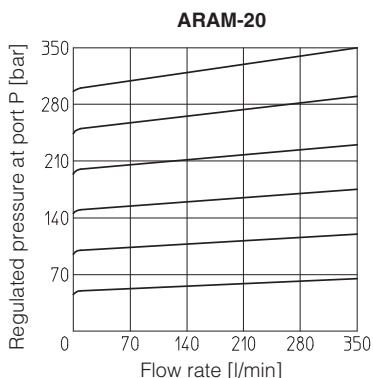

9 MINIMUM PRESSURE VERSUS FLOW DIAGRAMS based on mineral oil ISO VG 46 at 50°C

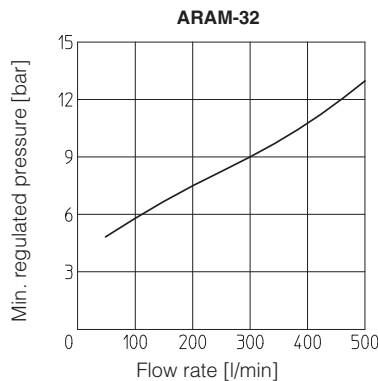
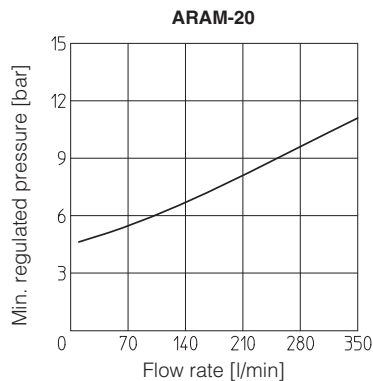

10 ELECTRIC CONNECTORS ACCORDING TO DIN 43650 for ARAM with solenoid valve (to be ordered separately, see tech table K800)

666 = standard connector IP-65, suitable for direct connection to electric supply source

667 = as 666, but with built-in signal led. Available for power supply voltage 24 AC or DC, 110 AC or DC, 220 AC or DC

11 SEALS AND HYDRAULIC FLUID - for other fluids not included in below table, consult our technical office

Seals, recommended fluid temperature	NBR seals (standard) = -20°C ÷ +80°C, with HFC hydraulic fluids = -20°C ÷ +50°C FKM seals (/PE option) = -20°C ÷ +80°C HNBR seals (/BT option) = -40°C ÷ +60°C, with HFC hydraulic fluids = -40°C ÷ +50°C		
Recommended viscosity	15 ÷ 100 mm ² /s - max allowed range 2,8 ÷ 500 mm ² /s		
Max fluid contamination level	ISO4406 class 20/18/15 NAS1638 class 9, see also filter section at www.atos.com or KTF catalog		
Hydraulic fluid	Suitable seals type	Classification	Ref. Standard
Mineral oils	NBR, FKM, HNBR	HL, HLP, HLPD, HVLP, HVLPD	DIN 51524
Flame resistant without water	FKM	HFDR, HFDR	ISO 12922
Flame resistant with water	NBR, HNBR	HFC	

12 DIMENSIONS [mm]

ARAM-20

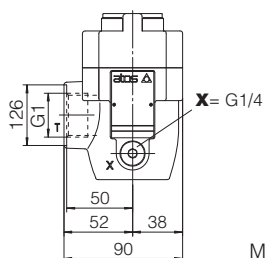
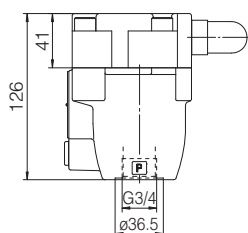

Mass: 3,9 Kg

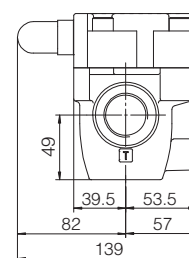

X = port connection for external pilot
Y = port connection for external drain

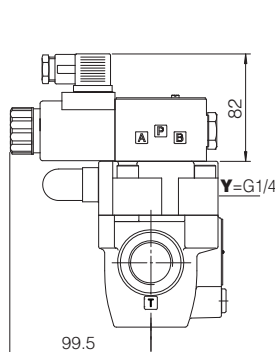

ARAM-20/10/-EX**
ARAM-20/11/-EX**

Mass: 5,7 Kg

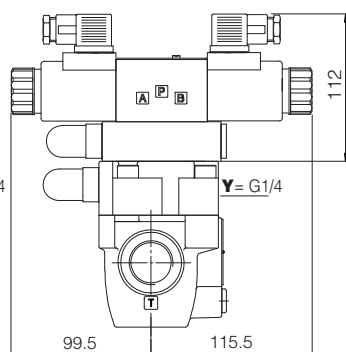

ARAM-20/20/-EX**
ARAM-20/21/-EX**

Mass: 7,7 Kg

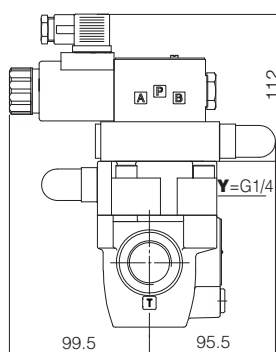

ARAM-20/22/-EX**

Mass: 7,2 Kg

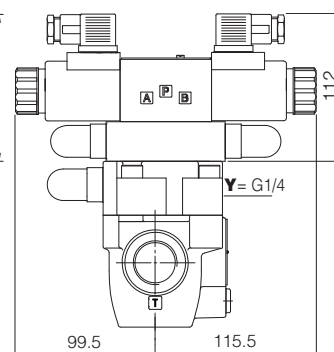

ARAM-20/32/-EX**

Mass: 8 Kg

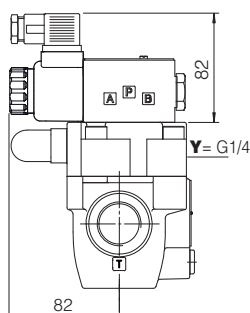

ARAM-20/10/-LX**
ARAM-20/11/-LX**

Mass: 5,5 Kg

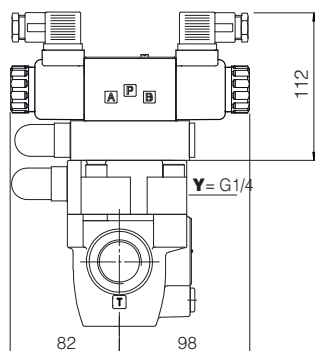

ARAM-20/20/-LX**
ARAM-20/21/-LX**

Mass: 7,3 Kg

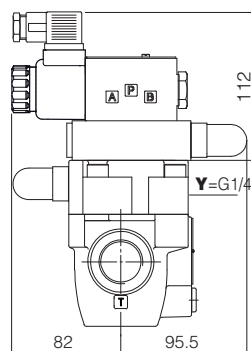

ARAM-20/22/-LX**

Mass: 7 Kg

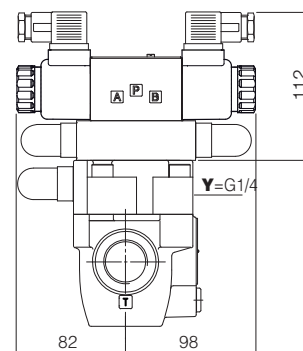

ARAM-20/32/-LX**

Mass: 7,6 Kg

ARAM-32

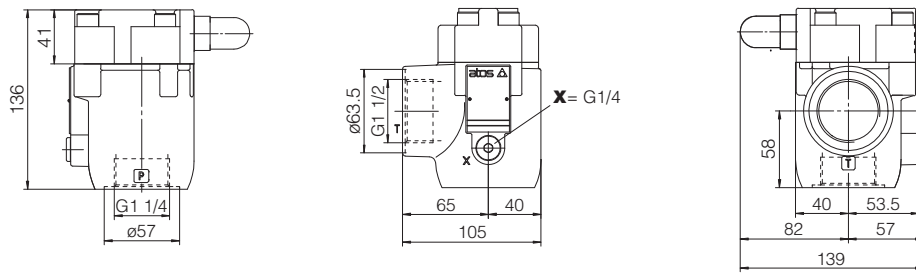

X = port connection for external pilot
Y = port connection for external drain

Mass: 4,7 Kg

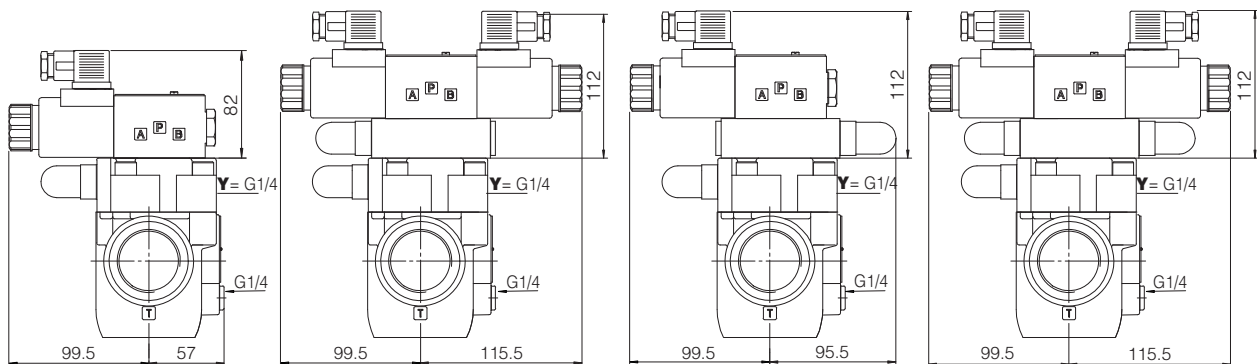

ARAM-32/10/-EX**
ARAM-32/11/-EX**

Mass: 6,5 Kg

ARAM-32/20/-EX**
ARAM-32/21/-EX**

Mass: 8,5 Kg

ARAM-32/22/-EX**

Mass: 7,9 Kg

ARAM-32/32/-EX**

Mass: 8,8 Kg

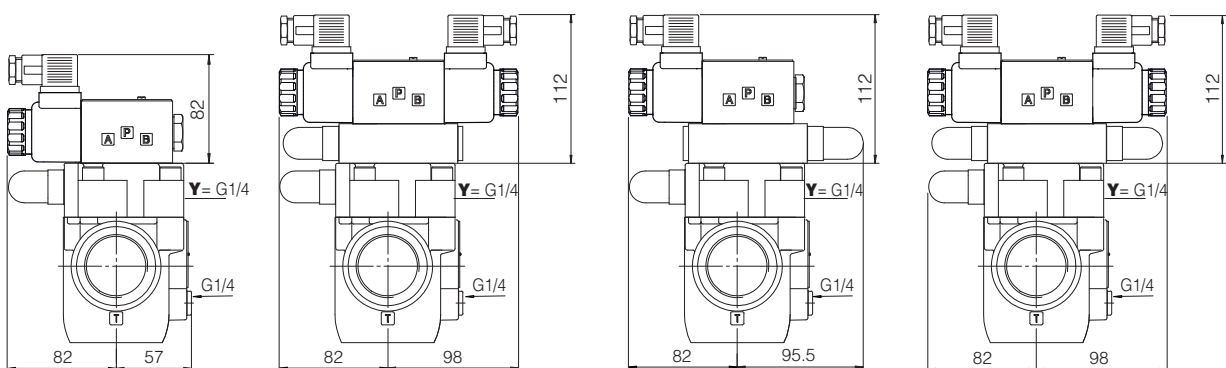

ARAM-32/10/-LX**
ARAM-32/11/-LX**

Mass: 6,3 Kg

ARAM-32/20/-LX**
ARAM-32/21/-LX**

Mass: 8,1 Kg

ARAM-32/22/-LX**

Mass: 7,7 Kg

ARAM-32/32/-LX**

Mass: 8,4 Kg

Overall dimensions refer to valves **DC** voltage, with connectors type 666