

Operating and maintenance information



safety PED pressure relief valves, conforming to PED Directive 2014/68/EU

This operating and maintenance information applies to Atos safety pressure relief valves conforming to Pressure Equipment Directive (PED) 2014/68/EU. It is intended to provide useful guidelines on the safe and proper assembly, commissioning, operation, use, maintenance and transport of PED valves. The prescriptions included in this document must be strictly observed to avoid damages and injury.



1 SYMBOL CONVENTIONS

Following symbols are used in this documentation to evidence particular risks to be carefully avoided. In the following are listed the symbol conventions with their meaning, in case of non-compliance with this operating and maintenance information.

| | | |
|--|--------------------------------------|---|
|  WARNING | Death or serious injury could occur | risk classes to ANSI Z535.6 / ISO 3864 |
|  CAUTION | Minor or moderate injury could occur | |
| NOTICE | Property damage could occur | |
|  | Information to be observed | |

2 GENERAL NOTES

This document is relevant to the installation, use and maintenance of on-off directional, flow and pressure control valves. It is intended for machine manufacturers, assemblers and system end-users.



WARNING
Personal injury and property damage may be caused by incorrect use of the products!

The products have been designed for use in industrial environments and may only be used in the appropriate way.

Before using Atos valves, the following requirements must be met to ensure the appropriate use of the products:

- personnel who uses Atos valves must first read and understand the operating and maintenance information, particularly the Safety Notes in section **5**
- the products must remain in their original state, no modifications are permitted
- damaged or faulty valves must not be installed or put into operation
- make sure that the products have been installed as described in section **6**

2.1 Warranty

The expiration of warranty results from the following operations:

- incorrect assembly and commissioning
- improper handling and storage, see 6.4
- improper use, see 5.2
- modification of the original condition

3 CERTIFICATION

Safety pressure relief valves are certified by DEKRA, according to Pressure Equipment Directive 2014/68/EU (PED).

They meet the requirements specified in: Module B - EU Type Examination - Production Type (Annex III) of Directive 2014/68/EU - PED category IV

4 COMPONENTS DESCRIPTION

This document applies to direct and pilot operated safety pressure relief valves type CART*/PED, ARE*/PED, ARAM*/PED, AGAM*/PED. These valves are designed to operate as safety components, limiting the maximum system pressure or to protect parts of the circuit from overpressure.

They are also used as safety valves to protect hydraulic accumulators.

The valves are factory set at the pressure level required by the customer.

The pressure adjustment screw of the valves is protected with a lead sealed plastic cap to avoid manumission of the factory setting.



Any tampering of the lead sealing invalidates the certification.

5 PRODUCT IDENTIFICATION EXAMPLES - nameplates

5.1 Screw-in cartridges type CART

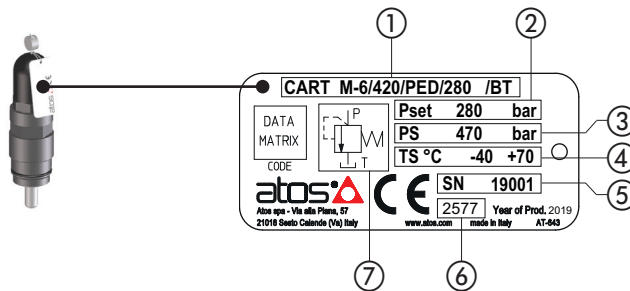

- ① Valve code
- ② Factory pressure setting
- ③ Burst pressure
- ④ Min ÷ Max fluid or ambient temperature range
- ⑤ Valve serial number (1)
- ⑥ Notified body reference number
- ⑦ Hydraulic symbol

5.2 In-line valves type ARE and ARAM

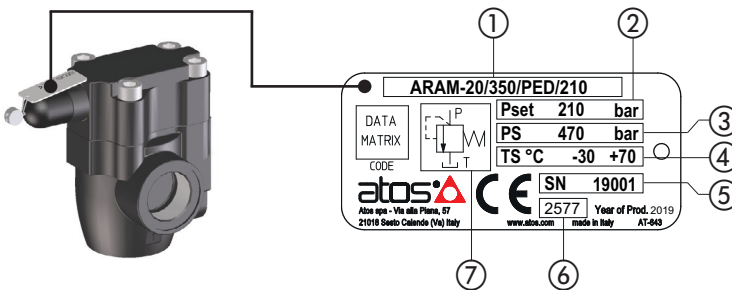

- ① Valve code
- ② Factory pressure setting
- ③ Burst pressure
- ④ Min ÷ Max fluid or ambient temperature range
- ⑤ Valve serial number (1)
- ⑥ Notified body reference number
- ⑦ Hydraulic symbol (simplified)

5.3 Subplate valves type AGAM

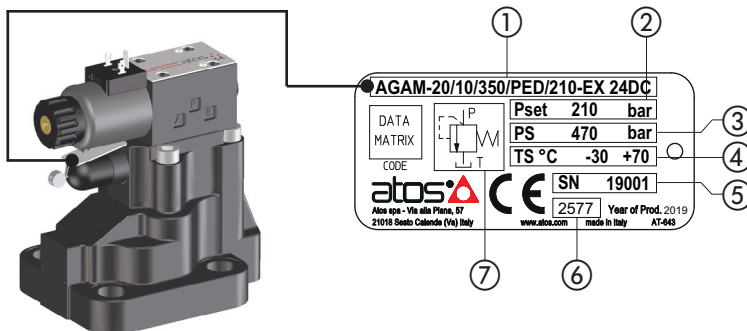

- ① Valve code
- ② Factory pressure setting
- ③ Burst pressure
- ④ Min ÷ Max fluid or ambient temperature range
- ⑤ Valve serial number (1)
- ⑥ Notified body reference number
- ⑦ Hydraulic symbol (simplified)

(1) Example for serial number:

| | | |
|--------------------|---|-----------------------|
| 19 | - | 001 |
| Year: 19 = 2019 | | Progressive number |

Note: nameplates may not be painted but must be kept in a readable condition

6 SAFETY NOTES

6.1 Intended use

Atos valves are intended for integration in industrial systems and machines or for the assembly with other components to form a machine or a system. They may only be operated under the environmental and operating conditions described in the valves technical tables.

6.2 Improper use

Any improper use of the components is not admissible.

Improper use of the product includes:

- Wrong installation
- Use of inappropriate or non-admissible hydraulic fluids
- Use outside of specified performance limits
- Use outside the specified temperature range
- The safety valves must not be used if the maximum system flow exceeds the value indicated as "max admissible" reported in the relevant technical table
- Manumission of the factory pressure setting
- Incorrect transport

6.3 Installation

Installation must be performed following the recommendations contained in the valves technical tables



Any tampering of the lead sealing invalidates the certification.



WARNING: fixing bolts - for AGAM

For the valve mounting, use only class 12.9 bolts, with dimensions and length reported in the valves technical tables.

Observe the specified tightening torque.

Using inappropriate fixing bolts or insufficient tightening torque, can cause the valve to loosen with consequent leakage of fluid under pressure which may cause personal injury and property damage.



CAUTION

Use of the valve outside the approved temperature range may lead to functional failures like overheating of the valve solenoid.

Only use the valve within the specified ambient and fluid temperature range.



CAUTION: penetrating water and humidity - for ARAM with solenoid valve

In case of use in humid or wet environments, water or humidity may penetrate at electrical connectors.

This may lead to malfunctions at the valve and to unexpected movements in the hydraulic system which may result in personal injury and damage to property:

- only use the valve within the intended IP protection class
- ensure that all seals and caps of the plug-in connections are tight and intact

NOTICE: dirt and foreign particles

Penetrating dirt and foreign particles lead to wear and malfunctions of the valves.

During assembly, be careful to prevent foreign particles such as metal chips getting into the valve or into the hydraulic system

Do not use linting fabric for the valve cleaning.



Environmental protection

Hydraulic fluids are harmful to the environment.

Leaking hydraulic fluid may lead to environmental pollution.

In case of fluid leakage immediately act to contain the problem.

Dispose of the hydraulic fluid in accordance with the currently applicable national regulations in your country.

Atos components do not contain substances hazardous for the environment.

The materials contained in Atos components are mainly: Copper, Steel, Aluminium, Electronic components, Rubber

Due to the high content of reusable metals, the main components of Atos can be completely recycled after disassembling of the relevant parts.

7 HYDRAULIC AND MECHANICAL INSTALLATION

Safety pressure relief valves must be used as supplied by Atos, without unduly opening, division and/or substitution of internal parts.

Oil direction: P→T
 Inlet oil port: P
 Outlet oil port: T

Pressure on the discharge line T must be close to zero.

Verify that the seals are in good conditions before install the valves in the system.

Screw-in cartridges type CART, must not be removed from their manifold after commissioning, in order to avoid the loosening of internal parts.



The end user must provide proper systems to avoid the cartridge disassembling.

ARE and ARAM in-line valves have to be assembled with proper fittings as per technical table **CY045**.

AGAM subplate valves have to be mounted on proper surfaces, using screws as per technical table **CY066**.

See also section 7.1 for tightening torque.

7.1 Tightening torque - for CART and AGAM

| Valve code |  |  |  Class 12.9 | Tightening torque (Nm) |
|-------------|---|---|--|------------------------|
| CART M-3 | 22 | | | 60 |
| CART M-4 | 17 | | | 25 |
| CART M-5 | 17 | | | 30 |
| CART M-6 | 27 | | | 55 |
| CART ARE-15 | 27 | | | 65 |
| CART ARE-20 | 36 | | | 140 |
| AGAM-10 | | 10 | n.4 M12x35 | 125 |
| AGAM-20 | | 14 | n.4 M15x50 | 300 |
| AGAM-32 | | 17 | n.4 M20x60 | 600 |

7.2 Application notes for valves ARAM and AGAM with pilot solenoid valve for multiple pressure selection.

The valve main regulation is factory set and lead sealed at the value required by the customer. This regulation corresponds to the max pressure controlled by the valve and it complies with the requirement of PED Directive 2014/68/EU.

The additional second and third pressure settings, selectable by the pilot solenoid valve, are without sealed regulation and they can be adjusted by the end user according to the system requirements.

The second and third pressure setting must be regulated at lower value respect to the lead sealed factory setting.

If the end user tries to adjust the second or third pressure setting at a higher value than the lead sealed factory setting, this last intervenes to limit the pressure according to PED requirements.

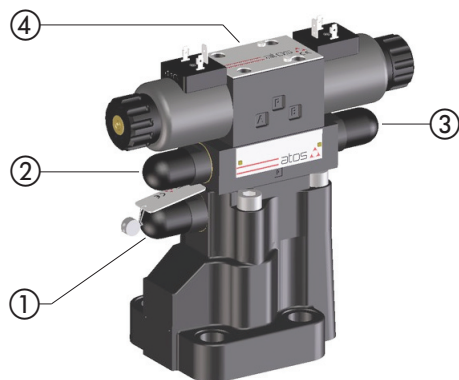

- ① Main pressure regulation - lead sealed factory setting
- ② Second pressure setting
- ③ Third pressure setting
- ④ Pilot solenoid valve

7.3 Hydraulic fluids and operating viscosity range

Mineral oils type HLP having high viscosity index are recommended.

The hydraulic fluids must be compatible with the selected seals.

Make sure that the working fluid is compatible with gas and dust present in the environment.

The type of fluid has to be selected in consideration of the effective working temperature range, so that the fluid viscosity remains at the optimal level.

| Hydraulic fluid | Suitable seals type | Classification | Ref. Standard |
|-------------------------------|---------------------|-----------------------------|---------------|
| Mineral oils | NBR, FKM, HNBR | HL, HLP, HLPD, HVLP, HVLDPD | DIN 51524 |
| Flame resistant without water | FKM | HF DU, HF DR | ISO 12922 |
| Flame resistant with water | NBR, HNBR | HFC | |

Fluid viscosity: 15 ÷ 100 mm²/s - max allowed range 2,8 ÷ 500 mm²/s

7.4 Filtration

The correct fluid filtration ensures a long service life of the valves and it prevent anomalous wearing or sticking.



Contamination in the hydraulic fluid may cause functional failures e.g. jamming or blocking of the valve spool / poppet. In the worst case, this may result in unexpected system movements and thus constitute a risk of injury.

Ensure adequate hydraulic fluid cleanliness according to the cleanliness classes of the valve over the entire operating range.

Max fluid contamination level:

ISO 4406 class 20/18/15 NAS 1638 class 9

Note: see also filter section at www.atos.com or KTF catalog

8 MAINTENANCE



Maintenance must be carried out only by qualified personnel with a specific knowledge of hydraulics and electrohydraulics

8.1 Ordinary maintenance

Safety pressure relief valves do not require specific maintenance.

A visual inspection is definitely useful to check the integrity of lead sealing and the absence of external oil leakages.

Periodically the external surface of the valve should be cleaned from dirt to allow a clear readability of the identification plate.

8.2 Repairing

Safety pressure relief valves are supplied as single assembled unit: spare parts are not allowed.

In case of incorrect functioning or beak-down it is recommended to send the valve back to Atos which will provide for the reparation.

Only for ARAM and AGAM versions equipped with pilot solenoid valve, the replacement of the pilot solenoid valve with another Atos valve of the same type and with the same function is allowed.

9 TRANSPORT AND STORAGE

9.1 Transport

Observe the following guidelines for transportation of valves:

- Before any movement check the valve weight reported in the technical table relevant to the specific component
- Use soft lifting belts to move or lift the heavy valves to avoid damages



WARNING

The valve may fall down and cause damage and injuries, if transported improperly.

Use personal protective equipment, such as: gloves, working shoes, safety goggles, working clothes, etc.



9.2 Storage

Valves are boxed using a VpCi protective packing system, offering best protection to oxidation during components sea transport or long storage in humid environments.

The valve surface is protected with a zinc coating, which guarantees a corrosion resistance of over 200 hours in the salt spray test. Additionally all valves are tested with mineral oil ISO VG 46; the oil film left after testing ensure the internal corrosion protection.

For the valves transporting and storing always observe the environmental conditions specified in the relevant technical tables. Improper storage may damage the product.

The valves can be stored for up to 12 months under the following conditions:

- If there is no specific information in the components technical tables, comply with a storage temperature of $-20\text{ }^{\circ}\text{C}$ to $+50\text{ }^{\circ}\text{C}$
- Do not store the valves outdoors
- Protect the valves against water and humidity in case of storage in open air
- Store the valves in the shelf or on a pallet
- Store the valves in the original packaging or comparable packaging in order to protect them from dust and dirt
- Remove the plastic covers from the valves mounting surface only before the assembly

In case of storage period longer than 12 months please contact our technical office