

Modular relief valves type SHMP, SKM

ISO 4401 sizes 06 and 10

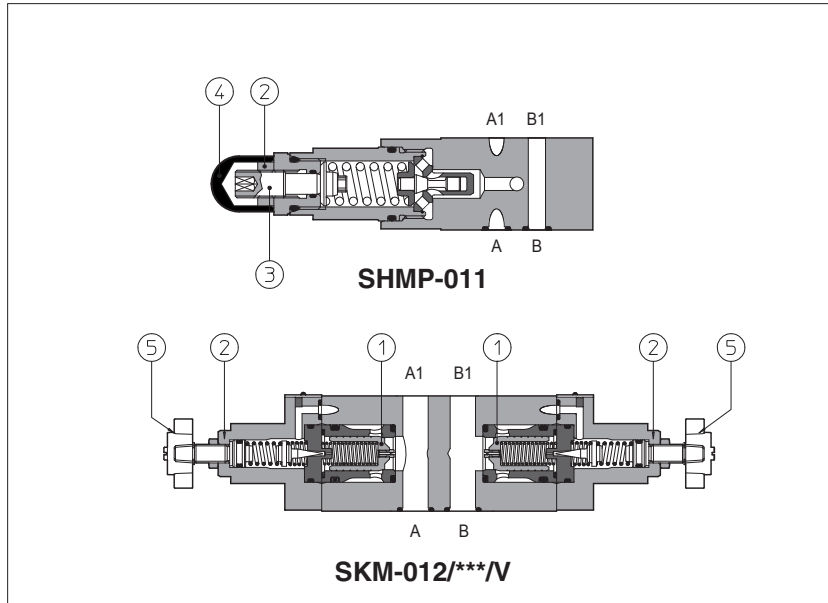

SHMP are direct operated pressure relief valves, size 06.

SKM are double stage pressure relief valves size 10 with balanced poppet ①.

The pressure adjustment is operated by loosening the locking nut ② and turning the screw ③ protected by cap ④. Optional versions with setting adjustment by handwheel ⑤ instead of the screw are available on request. Clockwise rotation increases the pressure.

Valve size and max flow:

SHMP = size 06, max flow: 35 l/min

SKM = size 10, max flow: 120 l/min

Mounting surface: **ISO 4401 size 06, 10**

Max pressure: up to **350 bar**

1 MODEL CODE

SHMP	-	011	/	210	/	V	/	**	/	*
Modular pressure relief valve size: SHMP = 06 SKM = 10								Series number		Seals material, see section ③: - = NBR PE = FKM BT = HNBR
Configuration, see section ②								Options: V = setting adjustment by handwheel instead of a grub screw protected by cap		
011 = single on port P, discharge to port T 012 = double on ports A and B, discharge to port T 013 = single on port A, discharge to port T 014 = single on port B, discharge to port T 015 = double on ports A and B, with the relieved pressure cross-discharged				Pressure range		SHMP: 50 = 2÷ 50 bar 100 = 3÷100 bar 210 = 10÷210 bar 350 = 15÷350 bar		SKM: 50 = 4÷ 50 bar 100 = 5÷100 bar 210 = 5÷210 bar 350 = 5÷350 bar		

2 HYDRAULIC CHARACTERISTICS

Hydraulic configuration

Valve model	SHMP				SKM			
Max flow [l/min]	35				120			
Pressure range [bar]	2÷50;	3÷100;	10÷210;	15÷350	4÷50;	5÷100;	5÷210;	5÷350

3 MAIN CHARACTERISTICS, SEALS and HYDRAULIC FLUIDS - for other fluids not included in below table, consult our technical office

Assembly position / location	Any position		
Subplate surface finishing	Roughness index Ra 0,4 - flatness ratio 0,01/100 (ISO 1101)		
MTTFd values according to EN ISO 13849	150 years (SHMP), 75 years (SKM), for further details see technical table P007		
Ambient temperature	Standard execution = -30°C ÷ +70°C /PE option = -20°C ÷ +70°C /BT option = -40°C ÷ +70°C		
Seals, recommended fluid temperature	NBR seals (standard) = -20°C ÷ +80°C, with HFC hydraulic fluids = -20°C ÷ +50°C FSKM seals (/PE option) = -20°C ÷ +80°C HNBR seals (/BT option) = -40°C ÷ +60°C, with HFC hydraulic fluids = -40°C ÷ +50°C		
Recommended viscosity	15 ÷ 100 mm ² /s - max allowed range 2.8 ÷ 500 mm ² /s		
Max fluid contamination level	ISO4406 class 20/18/15 NAS1638 class 9, see also filter section at www.atos.com or KTF catalog		
Hydraulic fluid	Suitable seals type	Classification	Ref. Standard
Mineral oils	NBR, FSKM, HNBR	HL, HLP, HLPD, HVLP, HVLPD	DIN 51524
Flame resistant without water	FSKM	HFDU, HFDR	ISO 12922
Flame resistant with water	NBR, HNBR	HFC	

4 REGULATED PRESSURE VERSUS FLOW DIAGRAMS (Based on mineral oil ISO VG 46 at 50°C)

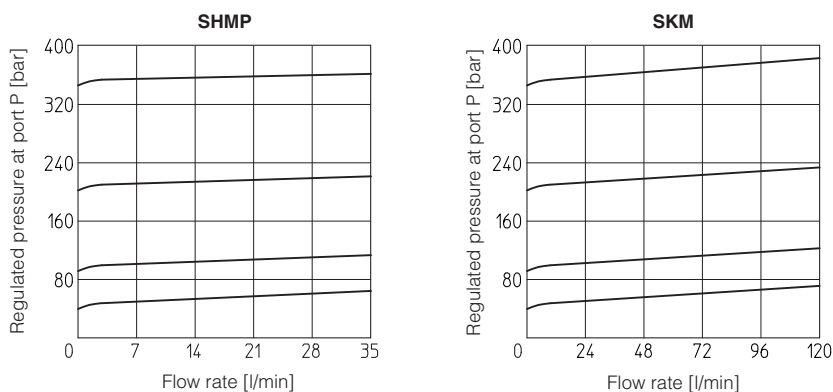

5 MINIMUM PRESSURE VERSUS FLOW DIAGRAMS (Based on fluid viscosity of 25 mm²/s at 40°C)

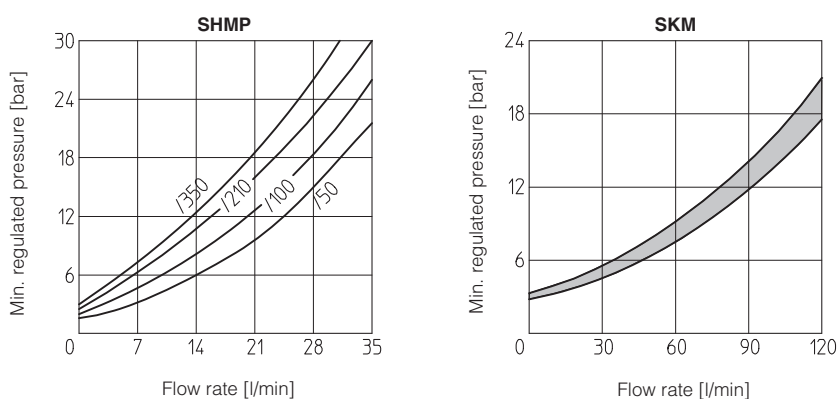

6 INSTALLATION DIMENSIONS OF SHMP VALVES [mm]

SHMP-011

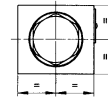
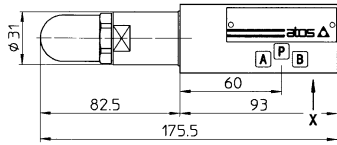
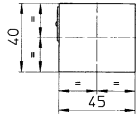

Mass: 1,4 Kg

SHMP-012

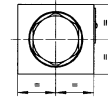
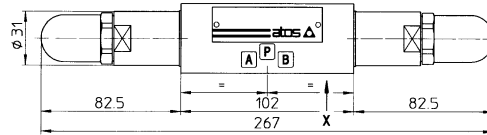
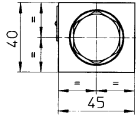

Mass: 1,7 Kg

SHMP-013
SHMP-014

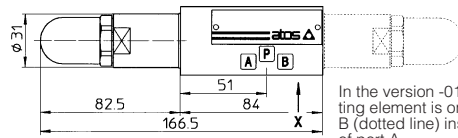
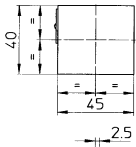

In the version -014 the regulating element is on side of port B (dotted line) instead of side of port A.

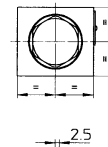

Mass: 1,2 Kg

SHMP-015

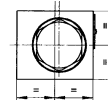
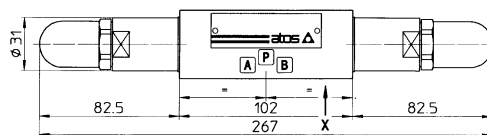
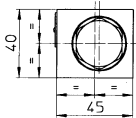

Mass: 1,7 Kg

Adjustment device for option /V

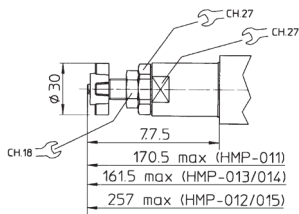

ISO 4401: 2005

Mounting surface: 4401-03-02-0-05

Diameter of ports A, B, P, T: $\varnothing = 7,5$ mm
Seals: 4 OR 108

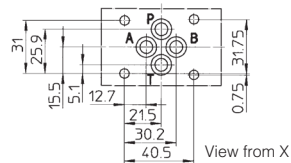

Fastening bolts: n° 4 socket head screws M5. The length depends on number and type of modular elements associated.

7 INSTALLATION DIMENSIONS OF SKM VALVES [mm]

SKM-011

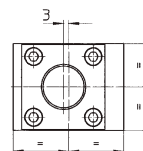
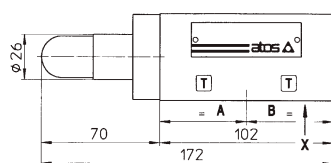
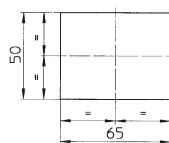

Mass: 2,5 Kg

SKM-012

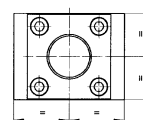
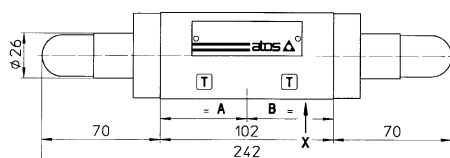
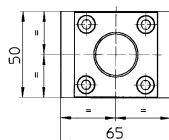

Mass: 2,8 Kg

SKM-013

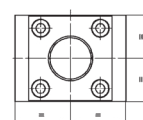
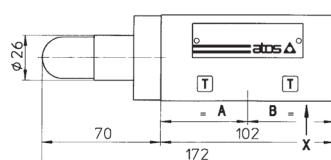
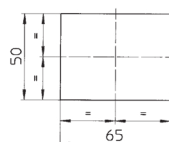

Mass: 2,5 Kg

SKM-014

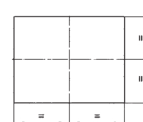
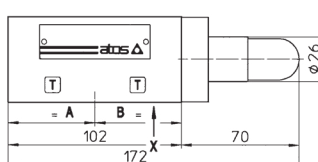
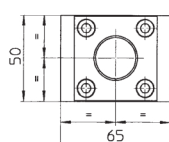

Mass: 2,5 Kg

SKM-015

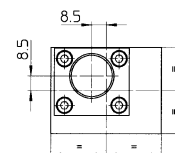
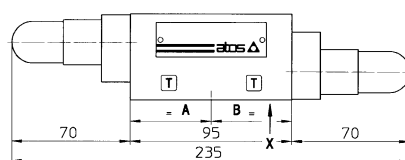
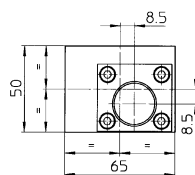

Mass: 2,5 Kg

Adjustment device for option /V

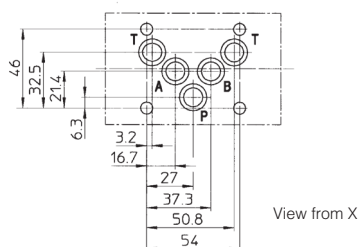
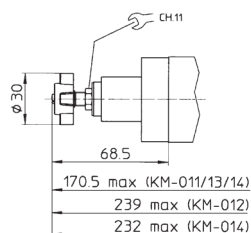

ISO 4401: 2005
 Mounting surface: 4401-05-04-0-05
 Diameter of ports A, B, P, T: $\varnothing = 11,2$ mm
 Seals: 5 OR 2050

Fastening bolts: n° 4 socket head screws M6. The length depends on number and type of modular elements associated.