

Solenoid directional valves type SDPHL

pilot operated, ISO 4401 size 16 and 25

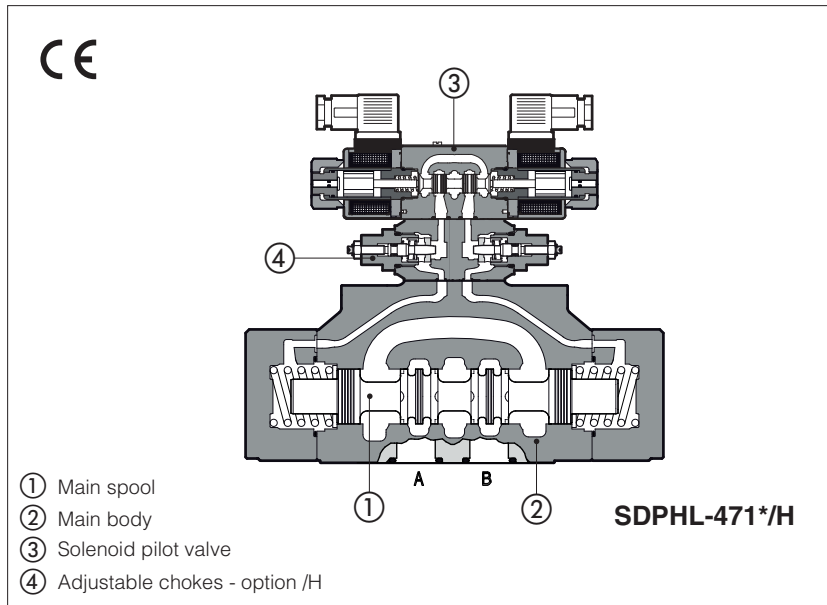

Spool type, pilot operated directional solenoid valves available in three or four way configurations.

They are operated by a directional valve ③ type SDHL (see technical table E018) equipped with threaded solenoids for AC or DC power supply.

Spools ① are fully interchangeable and they are available in a wide range of hydraulic configurations.

The valve body is made by shell-moulding castings ② machined by transfer lines and then cleaned by thermal deburring. Optimized flow paths largely cored with extrawide channels to tank ensures low pressure drops.

Valves can be supplied with following optional devices:

- Option /H, adjustable chokes for the valve's switching times control ④;
- Option /S, main spool stroke adjustment.

Rugged execution suitable for outdoor use.

Mounting surface: **ISO 4401 size 16, 25**

Max flow **up to 300 and 700 l/min.**

Pressure **up to 350 bar**

1 MODEL CODE

SDPH	L	- 2	61	1	/ A	- X	24 DC	**	/	*
Pilot operated directional control valve		Solenoid pilot valve: L = SDHL compact execution, AC and DC supply		Valve size: 2 = 16 4 = 25	Valve configuration, see section 2	61 = single solenoid, center plus external position, spring centered 63 = single solenoid, 2 external positions, spring offset 67 = single solenoid, center plus external position, spring offset 71 = double solenoid, 3 positions, spring centered 75 = double solenoid, 2 external positions, with detent	Series number	Seals material, see section 3: - = NBR PE = FKM		
Voltage code, see section 5							X = without connector See section 11 for available connectors, to be ordered separately XK = Deutsch connector			
Options, see section 4										

Note: SDPHL-* S PIL version without pilot solenoid valve available on request

2 CONFIGURATIONS and SPOOLS (representation according to ISO 1219-1, for functional scheme, see section 4)

Configurations	Spools	Configurations	Spools
<p>NOTES (see also section 4,2 for special shaped spools): - For SDPHL-6 are available only spools: 0, 1, 1/2, 2, 3, 4, 5, 58, 6, 7, 19, 91</p>			

3 MAIN CHARACTERISTICS, SEALS AND HYDRAULIC FLUID - for other fluids not included in below table, consult our technical office

Assembly position / location	Any position for all valves except for type -*70 (without springs) that must be installed with horizontal axis if operated by impulses.		
Subplate surface finishing	Roughness index Ra 0,4 - flatness ratio 0,01/100 (ISO 1101)		
MTTFd values according to EN ISO 13849	75 years, for further details see technical table P007		
Ambient temperature	Standard = -30°C ÷ +70°C; /PE option = -20°C ÷ +70°C;		
Seals, recommended fluid temperature	NBR seals (standard) = -20°C ÷ +80°C, with HFC hydraulic fluids = -20°C ÷ +50°C FKM seals (/PE option) = -20°C ÷ +80°C		
Recommended viscosity	15 ÷ 100 mm ² /s - max allowed range 2.8 ÷ 500 mm ² /s		
Max fluid contamination level	ISO4406 class 20/18/15 NAS1638 class 9, see also filter section at www.atos.com or KTF catalog		
Hydraulic fluid	Suitable seals type	Classification	Ref. Standard
Mineral oils	NBR, FKM	HL, HLP, HLPD, HVLP, HVLPD	DIN 51524
Flame resistant without water	FKM	HFDU, HFDR	ISO 12922
Flame resistant with water	NBR	HFC	
Flow direction	As shown in the symbols of table 2		
Operating pressure	P, A, B, X = 350 bar T = 250 bar for external drain (standard) T with internal drain (option /D) and port Y = 210 bar SDPHL (DC); 160 bar SDPHL (AC) Minimum pilot pressure = 8 bar		
Rated flow	See diagrams Q/Δp at section 6		
Maximum flow	SDPHL-2: 300 l/min ; SDPHL-4: 700 l/min ; (see rated flow at section 6 and operating limits at section 7)		

3.1 Coils characteristics

Insulation class	H (180°C) for DC coils F (155°C) for AC coils Due to the occurring surface temperatures of the solenoid coils, the European standards EN ISO 13732-1 and EN ISO 4413 must be taken into account
Protection degree to DIN EN 60529	IP 65 (with connectors 666, 667 correctly assembled)
Relative duty factor	100%
Supply voltage and frequency	See electric features 5
Supply voltage tolerance	± 10%

4 NOTES

4.1 Options

/A = Solenoid mounted at side of port A of main body (only for single solenoid valves).
In standard version, solenoid is mounted at side of port B.

/D = Internal drain (standard configuration is external drain)

/E = External pilot pressure (standard configuration is internal pilot pressure).

/R = Pilot pressure generator (4 bar on port P) see section 4.2

/S = Main spool stroke adjustment.

/WP = Prolonged manual override protected by rubber cap.

⚠ The manual override operation can be possible only if the pressure at T port is lower than 50 bar

Devices for main spool switching control and to reduce the hydraulic shocks at the valve operation

/H = Adjustable chokes (meter-out to the pilot chambers of the main valve).

/L1, /L2, /L3 = calibrated restrictors on A and B ports of the pilot valve: **L1** = 0,8mm, **L2** = 1mm, **L3** = 1,25mm

/L9 = plug with calibrated restrictor in P port of pilot valve - see section 9

Suggested for pilot pressure higher than 210 bar or to limit the hydraulics shocks caused by the fast main spool switching

4.2 Special shaped spools

- spools type **0** and **3** are also available as **0/1** and **3/1** with restricted oil passages in central position, from user ports to tank.

- spools type **1, 4** are also available as **1/1** and **4/8** that are properly shaped to reduce water-hammer shocks during the switching (to use with option /L*).

Shaped spool availability	0/1	3/1	1/1	4/8
SDPHL-2, SDPHL-4	•	•	•	•

4.3 Pilot pressure generator (option /R)

The device **/R** generates an additional pressure drop, in order to ensure the minimum pilot pressure, for correct operation of the valves with internal pilot and fitted with spools type **0, 0/1, 4, 4/8, 5, 58**. The device **/R** has to be fitted when the pressure drop in the valve, verified on flow versus pressure diagrams, is lower than the minimum pilot pressure value.

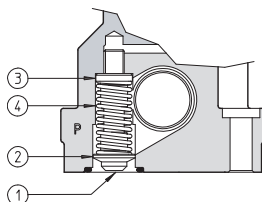

- ① Flapper-guide
- ② Flapper
- ③ Spring stop-washer
- ④ Spring

FUNCTIONAL SCHEME (config. 71)
example of switching control options

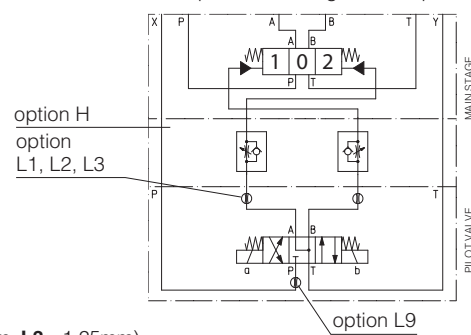

5 ELECTRIC FEATURES

Valve	External supply nominal voltage ± 10%	Voltage code	Type of connector	Power consumption (2)	Code of spare coil	
					X version	XK version
SDPHL	12 DC	12 DC	666 or 667	30 W	COL-12DC	COLK-12DC
	14 DC	14 DC			COL-14DC	COLK-14DC
	24 DC	24 DC			COL-24DC	COLK-24DC
	28 DC	28 DC			COL-28DC	COLK-28DC
	110/50 AC	110/50/60 AC		COL-110/50/60AC (1)	-	
	230/50 AC	230/50/60 AC		COL-230/50/60AC (1)	-	

- (1) Coil can be supplied also with 60 Hz of voltage frequency: in this case the performances are reduced by 10÷ 15% and the power consumption is 58 VA
- (2) Average values based on tests performed at nominal hydraulic condition and ambient/coil temperature of 20°C.
- (3) When solenoid is energized, the inrush current is approx 3 times the holding current. Inrush current values correspond to a power consumption of about 150 VA.

6 FLOW VERSUS PRESSURE DIAGRAMS Based on mineral oil ISO VG 46 at 50°C

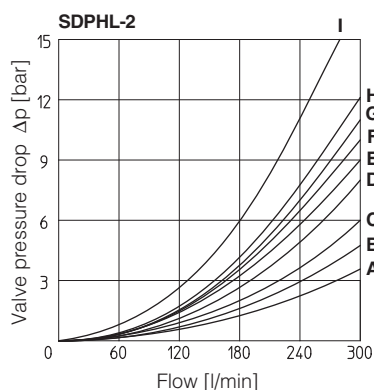

Spool type	Flow direction				
	P→A	P→B	A→T	B→T	P→T
0/2, 1, 3, 6, 7	A	A	D	A	-
1/1, 1/2	B	B	D	E	-
0	A	A	D	E	C
0/1	A	A	D	-	-
2	A	A	-	-	-
2/2	B	B	-	-	-
3/1	A	A	D	D	-
4	C	C	H	I	F
4/8	C	C	G	I	F
5	A	B	F	H	G
19	C	-	-	G	-
39	C	-	-	H	-
49	-	D	-	-	-
58	B	A	F	H	H
91	C	C	E	-	-
93	-	C	D	-	-

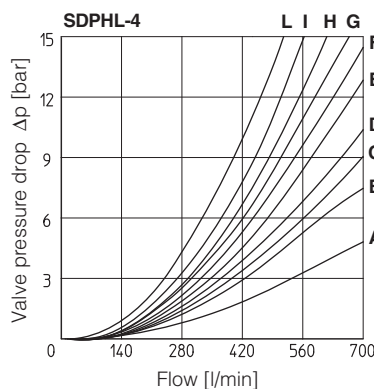

Spool type	Flow direction				
	P→A	P→B	A→T	B→T	P→T
1	B	B	B	D	-
1/1	D	E	E	F	-
1/2	E	D	B	C	-
0	D	C	D	E	F
0/1, 3/1, 6, 7	D	D	D	F	-
0/2	D	D	D	E	-
2	B	B	-	-	-
2/2	E	D	-	-	-
3	B	B	D	F	-
4	C	C	H	L	L
5	A	D	D	D	H
19	F	-	-	E	-
39	G	F	-	F	-
58	E	A	B	F	H
91	F	F	D	-	-
93	-	G	D	-	-

7 OPERATING LIMITS For a correct valve operation do not exceed the max recommended flow rates (l/min) shown in the below tables

SDPHL-2

Spool	Inlet pressure [bar]			
	70	140	210	350
	Flow rate [l/min]			
0, 1, 3, 6, 7, 8	300	300	300	300
2, 4, 4/8	300	300	240	140
5	260	220	180	100
0/1, 0/2, 1/2	300	250	210	180
58, *9, 9*	300	300	270	200

SDPHL-4

Spool	Inlet pressure [bar]			
	70	140	210	350
	Flow rate [l/min]			
1, 6, 7, 8	700	700	700	600
2, 4, 4/8	500	500	450	400
5, 0/1, 0/2, 1/2	600	520	400	300
0, 3	700	700	600	540
58, *9, 9*	500	500	500	450

8 SWITCHING TIMES (average values in m sec)

Valve model	Configuration		Piloting pressure					
			70 bar		140 bar		250 bar	
			Alternating current	Direct current	Alternating current	Direct current	Alternating current	Direct current
SDPHL-2	71, 61, 67, 61*/A, 67*/A	Switch ON	40	55	30	50	20	40
		Switch OFF	60					
	63, 63*/A	Switch ON	55	80	45	70	35	55
		Switch OFF	95					
SDPHL-4	71, 61, 67, 61*/A, 67*/A	Switch ON	60	80	45	60	30	45
		Switch OFF	80					
	63, 63*/A	Switch ON	95	115	75	95	50	65
		Switch OFF	130					

Notes:

- 1) For configuration 75, times of switching ON and switching OFF are the same: this value is equal to time of switch ON of configuration 63.
- 2) TEST CONDITIONS
 - Nominal voltage supply DC (direct) and AC (alternating) with connector type SP-666. The use of other connectors can affect the switching time;
 - 2 bar of counter pressure on port T;
 - mineral oil: ISO VG 46 at 50°C
- 3) The response time is affected by elasticity of the hydraulic circuit, by variation of hydraulic characteristics and temperature.

9 PLUGS LOCATION FOR PILOT/DRAIN CHANNELS

Depending on the position of internal plugs, different pilot/drain configurations can be obtained as shown below. To modify the pilot/drain configuration, proper plugs must only be interchanged. The plugs have to be sealed using loctite 270. Standard valves configuration provides internal pilot and external drain

SDPHL-2

Pilot channels

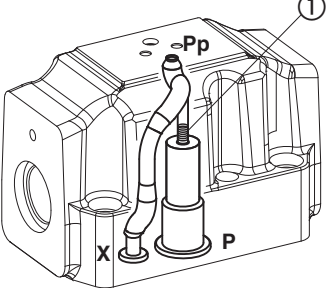

Drain channels

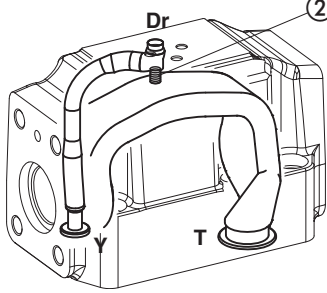

Internal piloting: Without blinded plug SP-X300F ①;
External piloting: Add blinded plug SP-X300F ①;
Internal drain: Without blinded plug SP-X300F ②;
External drain: Add blinded plug SP-X300F ②.

Option L9
 This option provides a calibrated restrictor PLUG-H-12A (Ø 1,2 mm) in the P port of the pilot valve

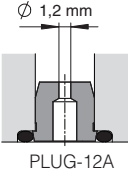

SDPHL-4

Pilot channels

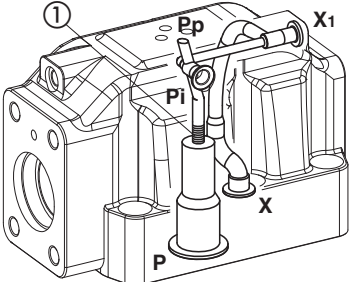

Drain channels

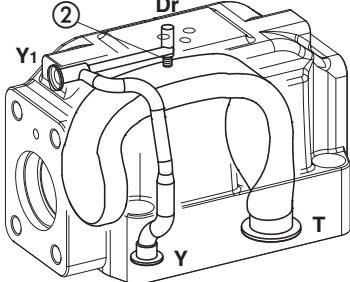

Internal piloting: Without blinded plug SP-X500F ①;
External piloting: Add blinded plug SP-X500F ①;
Internal drain: Without blinded plug SP-X300F ②;
External drain: Add blinded plug SP-X300F ②.

Option L9
 This option provides a a calibrated restrictor PLUG-H-15A (Ø 1,5 mm) in the P port of the pilot valve

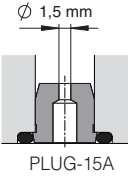

10 ELECTRIC CONNECTORS ACCORDING TO DIN 43650 - the connectors must be ordered separately

Connector code	Function
666	Connector IP65, suitable for direct connection to electric supply source
667	As 666 connector IP65 but with built-in signal led, suitable for direct connection to electric supply source

11 DIMENSIONS FOR SDPHL-2 [mm]

SDPHL-2*

ISO 4401: 2005

Mounting surface: 4401-07-07-0-05

Fastening bolts:

4 socket head screws M10x50 class 12.9

Tightening torque = 70 Nm

2 socket head screws M6x45 class 12.9

Tightening torque = 15 Nm

Diameter of ports A, B, P, T: $\varnothing = 20$ mm;

Diameter of ports X, Y: $\varnothing = 7$ mm;

Seals: 4 OR 130, 2 OR 2043

P = PRESSURE PORT

A, B = USE PORT

T = TANK PORT

X = EXTERNAL OIL

PILOT PORT

Y = DRAIN PORT

Stroke adjustment device for option /S

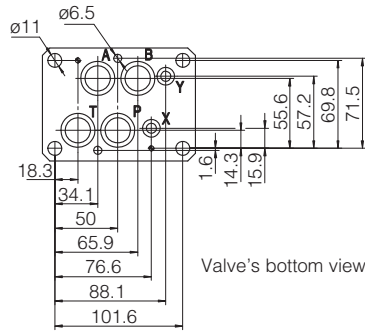
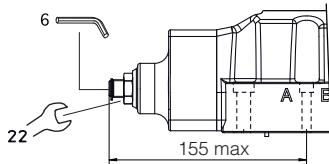

Valve's bottom view

Mass (Kg)	
SDPHL-26	9,7
SDPHL-27	9,9
Option /S	+1,0
Option H	+1,0

SDPHL-2*/H

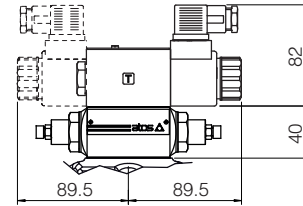

SDPHL-2*

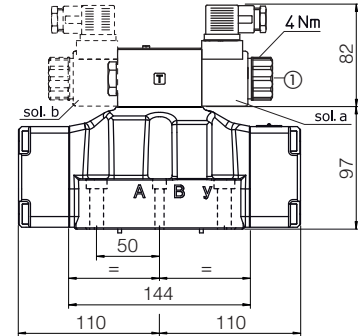
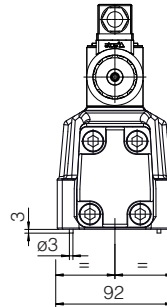

Overall dimensions refer to valves with connectors type 666

① Standard manual override PIN

12 DIMENSIONS FOR SDPHL-4 [mm]

SDPHL-4*

ISO 4401: 2005

Mounting surface: 4401-08-08-0-05

Fastening bolts:

6 socket head screws M12x60 class 12.9

Tightening torque = 125 Nm

Seals: 4 OR 4112; 2 OR 3056

Diameter of ports A, B, P, T: $\varnothing = 24$ mm;

Diameter of ports X, Y: $\varnothing = 7$ mm;

P = PRESSURE PORT

A, B = USE PORT

T = TANK PORT

X = EXTERNAL OIL PILOT PORT

Y = DRAIN PORT

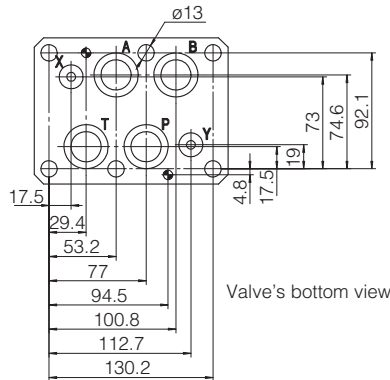
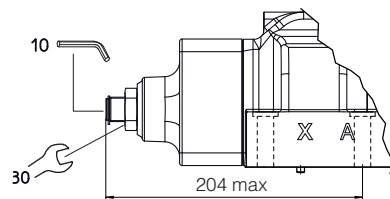

Valve's bottom view

Mass (Kg)	
SDPHL-46	17,2
SDPHL-47	17,4
Option /S	+1,5
Option H	+1,0

SDPHL-4*/H

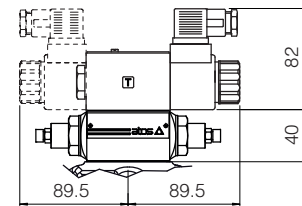

SDPHL-4*

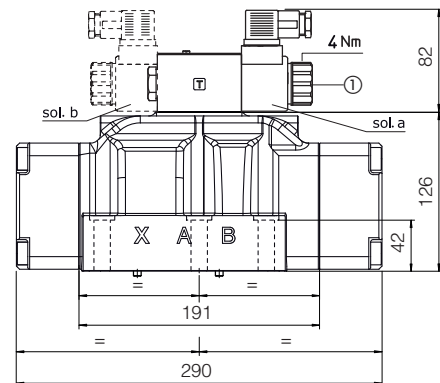
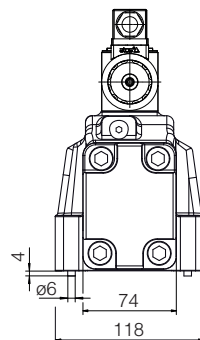

Overall dimensions refer to valves with connectors type 666

① Standard manual override PIN