

Servoproportional directional valves

piloted, with two LVDT transducers and zero spool overlap

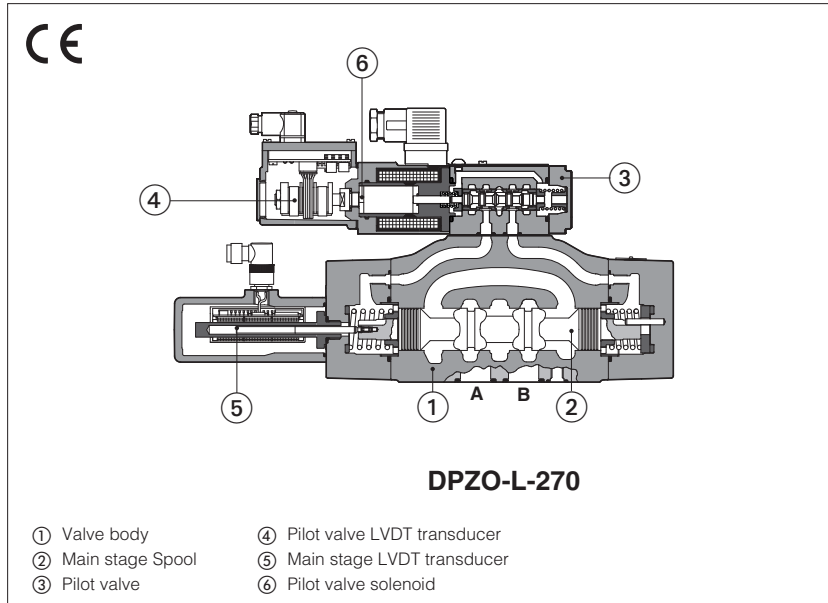

DPZO-L

Servoproportional directional valves, piloted, with two LVDT position transducer and zero spool overlap for position closed loop controls.

The valves operate in association with digital off-board divers or axis card, see section [2](#).

The two LVDT transducers (pilot and main stage) grant very high regulation accuracy and response sensitivity.

With de-energized proportional solenoids, full open position of the main stage spool is performed by configuration 60 or central position is performed by configuration 70, see section [10](#).

Spools regulation characteristics:

L = linear

DL = differential-linear, for control of actuators with area ratio 1:2

T = non linear, for fine low flow control

Size: **10 ÷ 32** - ISO 4401

Max flow: **180 ÷ 1600 l/min**

Max pressure: **350 bar**

1 MODEL CODE

DPZO	-	L	-	2	-	70	-	L	/	5	/	*	/	*	/	*
<p>Servoproportional directional valve, piloted</p> <p>L = two LVDT transducers</p> <p>Valve size ISO 4401: 1 = 10 2 = 16 4 = 25 4M = 27 6 = 32</p> <p>Configuration:</p> <div style="display: flex; justify-content: space-around;"> <div style="text-align: center;"> <p>Standard</p> <p>60 = </p> <p>70 = </p> </div> <div style="text-align: center;"> <p>Option /B</p> <p></p> <p></p> </div> </div> <p>Spool type, regulating characteristics:</p> <div style="display: flex; justify-content: space-around;"> <div style="text-align: center;"> <p>L = linear</p> </div> <div style="text-align: center;"> <p>DL = differential-linear P-A = Q, B-T = Q/2 P-B = Q/2, A-T = Q</p> </div> <div style="text-align: center;"> <p>T = non linear (2)</p> </div> </div>																
<p style="text-align: right;">Seals material, see section 6 :</p> <p>- = NBR PE = FKM BT = NBR low temperature</p> <p style="text-align: right;">Series number</p>																

Hydraulic options (1):

B = solenoid and LVDT transducer at side of port B of the main stage (side A of pilot valve)

D = internal drain

E = external pilot pressure

G = pressure reducing valve for piloting

Spool size:	3 (L)	5 (L,DL)	5 (L)	5 (T)
DPZO-1 =	-	100	-	-
DPZO-2 =	160	250	-	190
DPZO-4 =	-	480	-	-
DPZO-4M =	-	550	-	-
DPZO-6 =	-	-	640	-

Nominal flow (l/min) at Δp 10bar P-T

(1) All combination possible

(2) Only for DPZO-L-270

2 OFF-BOARD ELECTRONIC DRIVERS

Please include in the driver order also the complete code of the connected proportional valve.

Drivers model	E-BM-LEB	E-BM-LID	E-BM-LES	Z-BM-LEZ
Type	Digital	Digital	Digital	Digital
Format	DIN-rail panel	DIN-rail panel	DIN-rail panel	DIN-rail panel
Tech table	GS230	GS235	GS240	GS330

3 GENERAL CHARACTERISTICS

Assembly position	Any position
Subplate surface finishing to ISO 4401	Acceptable roughness index: Ra ≤ 0,8, recommended Ra 0,4 – Flatness ratio 0,01/100
MTTFd valves according to EN ISO 13849	75 years, for further details see technical table P007
Ambient temperature range	Standard = -20°C ÷ +60°C /PE option = -20°C ÷ +60°C /BT option = -40°C ÷ +60°C
Storage temperature range	Standard = -20°C ÷ +70°C /PE option = -20°C ÷ +70°C /BT option = -40°C ÷ +70°C
Surface protection	Zinc coating with black passivation
Corrosion resistance	Salt spray test (EN ISO 9227) > 200 h
Vibration resistance	See technical table G004
Compliance	CE according to EMC directive 2014/30/EU (Immunity: EN 61000-6-2; Emission: EN 61000-6-3) RoHS Directive 2011/65/EU as last update by 2015/863/EU REACH Regulation (EC) n°1907/2006

4 HYDRAULIC CHARACTERISTICS - based on mineral oil ISO VG 46 at 50 °C

Valve model	DPZO-L-1	DPZO-L-2			DPZO-L-4	DPZO-L-4M	DPZO-L-6
Pressure limits [bar]	ports P, A, B, X = 350; T = 250 (10 for option /D); Y = 10;						
Spool type	L5, DL5	L3	L5, DL5	T5	L5, DL5		L5
Nominal flow Δp P-T [l/min] (1)							
Δp= 10 bar	100	160	250	190	480	550	640
Δp= 30 bar	160	270	430	330	830	950	1100
Max permissible flow [l/min]	180	400	550	550	1000	1100	1600
Piloting pressure [bar]	min. = 25; max = 350 (option /G advisable for pilot pressure > 200 bar)						
Piloting volume [cm³/min]	1,4	3,7			9	11,3	21,6
Piloting flow (2) [l/min]	3,5	9			18	20	19
Leakage (3) Pilot [cm³/min]	100 / 300	150 / 450			200 / 600	200 / 600	900 / 2800
Main stage [l/min]	0,4 / 1,2	0,6 / 2,5			1,0 / 4,0	1,0 / 4,0	3,0 / 9,0
Response time (4) [ms]	≤ 25	≤ 25			≤ 30	≤ 35	≤ 80
Hysteresis	≤ 0,1 [%of max regulation]						
Repeatability	± 0,1 [%of max regulation]						
Thermal drift	zero point displacement < 1% at ΔT = 40°C						

(1) For different Δp, the max flow is in accordance to the diagrams in section 7.2

(3) At p = 100/350 bar

(2) With step reference input signal 0 ÷ 100 %

(4) 0-100% step signal, see detailed diagrams in section 7.3

5 ELECTRICAL CHARACTERISTICS

Max power consumption	30 W
Max. solenoid current	2,6 A
Coil resistance R at 20°C	3 ÷ 3,3 Ω
Insulation class	H (180°) Due to the occurring surface temperatures of the solenoid coils, the European standards ISO 13732-1 and EN982 must be taken into account
Protection degree to DIN EN60529	IP65 with mating connectors
Duty factor	Continuous rating (ED=100%)

6 SEALS AND HYDRAULIC FLUIDS - for other fluids not included in below table, consult our technical office

Seals, recommended fluid temperature	NBR seals (standard) = -20°C ÷ +60°C, with HFC hydraulic fluids = -20°C ÷ +50°C FKM seals (/PE option) = -20°C ÷ +80°C HNBR seals (/BT option) = -40°C ÷ +60°C, with HFC hydraulic fluids = -20°C ÷ +50°C		
Recommended viscosity	20 ÷ 100 mm²/s - max allowed range 15 ÷ 380 mm²/s		
Max fluid contamination level	normal operation	ISO4406 class 18/16/13 NAS1638 class 7	see also filter section at www.atos.com or KTF catalog
	longer life	ISO4406 class 16/14/11 NAS1638 class 5	
Hydraulic fluid	Suitable seals type	Classification	Ref. Standard
Mineral oils	NBR, FKM, NBR low temp.	HL, HLP, HLPD, HVLP, HVLPD	DIN 51524
Flame resistant without water	FKM	HFDU, HFDR	ISO 12922
Flame resistant with water	NBR, NBR low temp.	HFC	

7 DIAGRAMS (based on mineral oil ISO VG 46 at 50 °C)

7.1 Regulation diagrams (values measure at Δp 10 bar P-T)

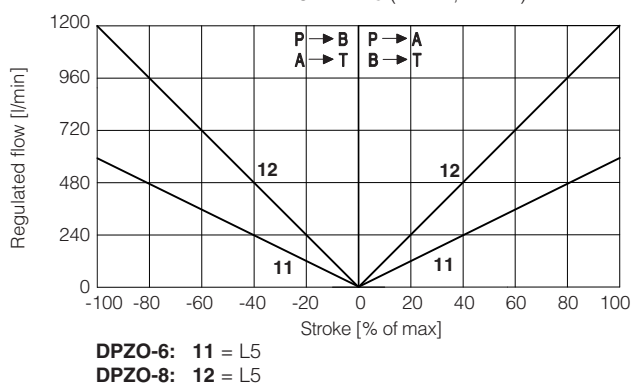
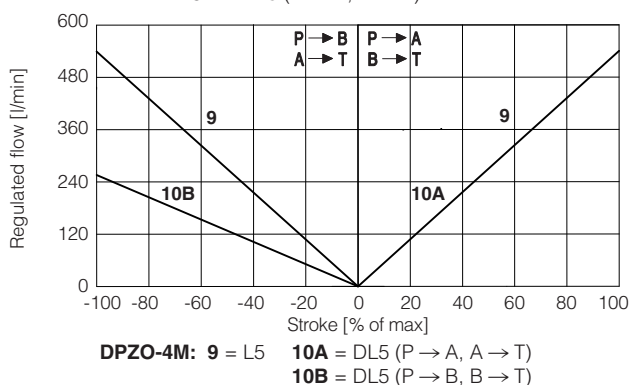
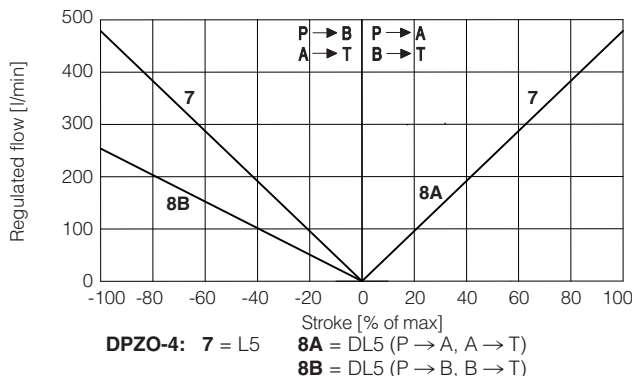
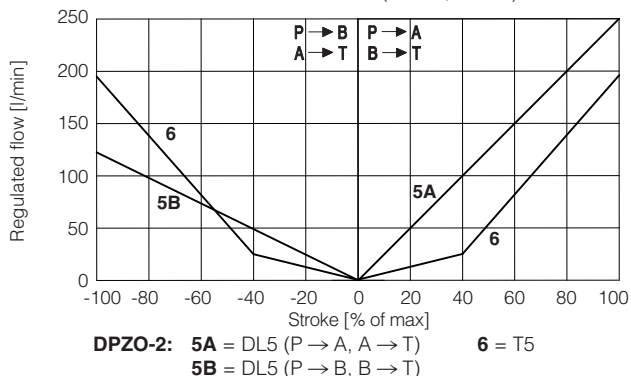
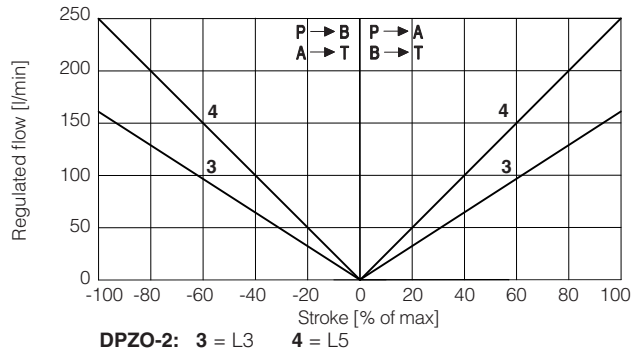
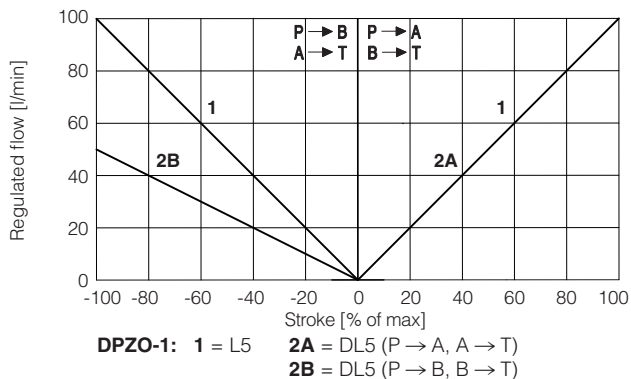

7.2 Flow / Δp diagram - stated at 100% of spool stroke

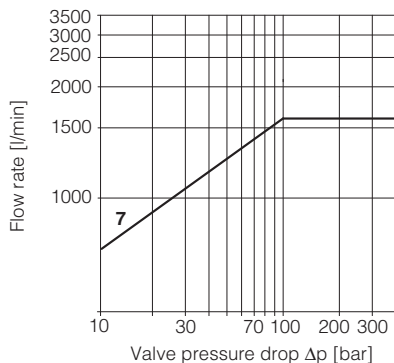
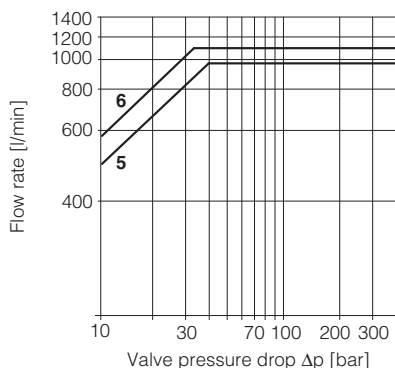
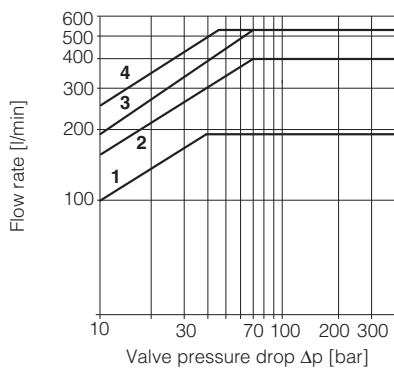

- DPZO-1: 1 = spools L5, DL5
- DPZO-2: 2 = spools L3
3 = spool T5
4 = spools L5, DL5
- DPZO-4: 5 = spools L5, DL5
- DPZO-4M: 6 = spools L5, DL5
- DPZO-6: 7 = L5

Note: Hydraulic configuration vs. reference signal for configurations 60 and 70 (standard and option /B)

Reference signal $\left. \begin{matrix} 0 \div +10 \text{ V} \\ 12 \div 20 \text{ mA} \end{matrix} \right\} P \rightarrow A / B \rightarrow T$

Reference signal $\left. \begin{matrix} 0 \div -10 \text{ V} \\ 4 \div 12 \text{ mA} \end{matrix} \right\} P \rightarrow B / A \rightarrow T$

7.3 Response time

The response times in below diagrams are measured at different steps of the reference input signal. They have to be considered as average values. For the valves with digital electronics the dynamics performances can be optimized by setting the internal software parameters.

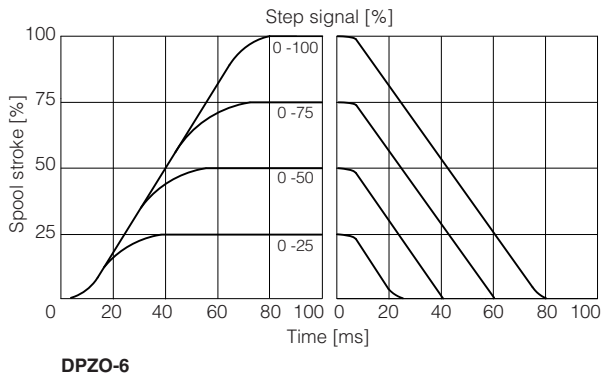
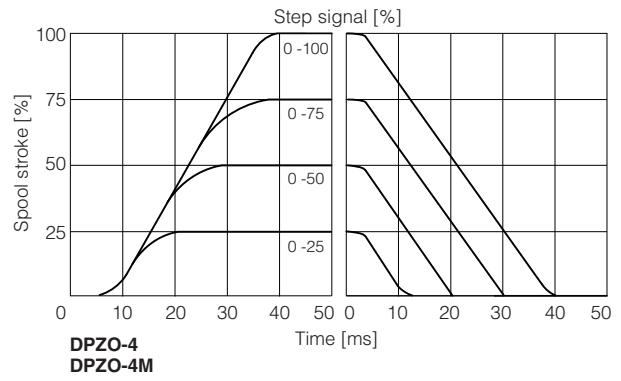
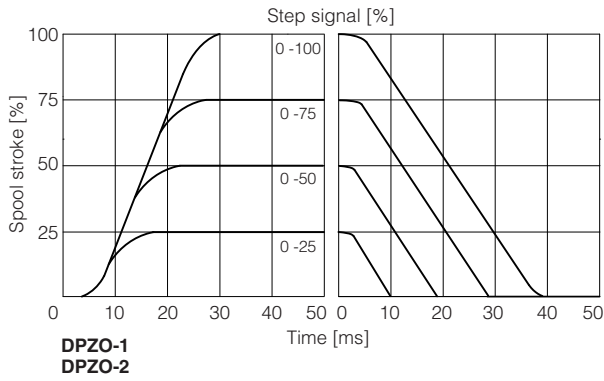

7.4 Bode diagrams

Stated at nominal hydraulic conditions.

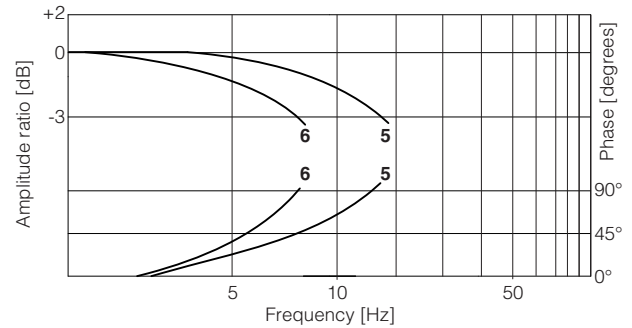
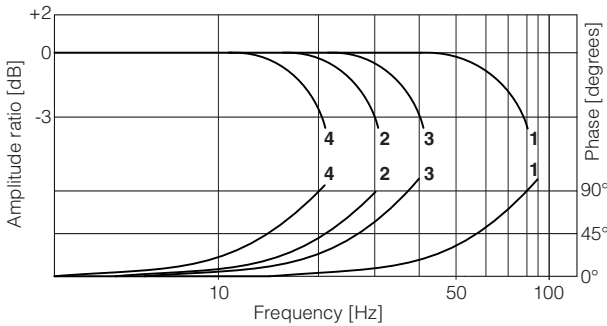

- | | |
|--------------------------|----------------------------|
| 1 = DPZO-1 } ± 5% | 2 = DPZO-1 } ± 100% |
| DPZO-2 } ± 5% | DPZO-2 } ± 100% |
| 3 = DPZO-4 } ± 5% | 4 = DPZO-4 } ± 100% |
| DPZO-4M } ± 5% | DPZO-4M } ± 100% |
| 5 = DPZO-6 } ± 5% | 6 = DPZO-6 } ± 100% |

7.5 Pressure gain

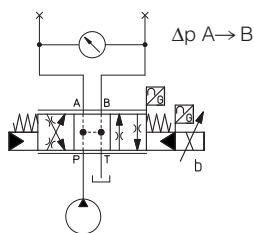

- 7** = DPZO-1
8 = DPZO-2
DPZO-4
DPZO-4M
DPZO-6

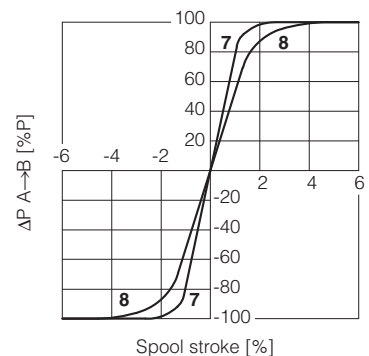

8 HYDRAULIC OPTIONS

B = Solenoid and LVDT transducer at side of port B of the main stage (side A of pilot valve). For hydraulic configuration vs reference signal, see 7.1

D = Internal drain (through port T).

Pilot and drain configuration can be modified as shown in the functional scheme here aside. For detailed view of plugs position, see section 12

The valve's standard configuration provides internal pilot and external drain.

E = External pilot (through port X).

Pilot and drain configuration can be modified as shown in the functional scheme here aside. For detailed view of plugs position, see section 12

The valve's standard configuration provides internal pilot and external drain.

G = Pressure reducing valve ③ with fixed setting, installed between pilot valve and main body. Reduced pressure setting:

DPZO-2 = **28 bar**

DPZO-1, DPZO-2, DPZO-4(M) and DPZO-6 = **40 bar**

It is advisable for valves with internal pilot in case of system pressure higher than 150 bar.

Pressure reducing valve ③ is standard for DPZO-1, for other sizes add /G option.

Functional Scheme - example of configuration 70

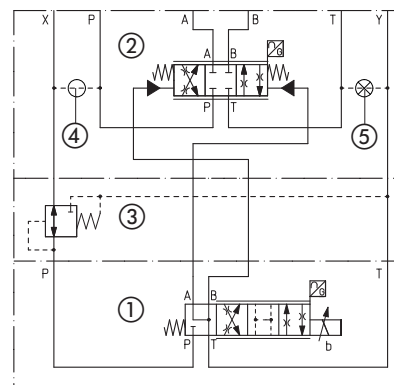

- ① Pilot valve
- ② Main stage
- ③ Pressure reducing valve
- ④ Plug to be added for external pilot trough port X
- ⑤ Plug to be removed for internal drain through port T

9 ELECTRICAL CONNECTION - connectors supplied with the valve

9.1 Pilot valve solenoid connector

PIN	SIGNAL	TECHNICAL SPECIFICATION	Connector code 666
1	COIL	Power supply	
2	COIL	Power supply	
3	GND	Ground	

9.3 LVDT main stage transducer connector

PIN	SIGNAL	TECHNICAL SPECIFICATION	Connector code ZBE-08
1	PROG	Do not connect	
2	VT+	Power supply +15Vdc	
3	AGND	Ground	
4	TR	Output signal	
5	VT-	Power supply -15Vdc	

9.2 LVDT pilot transducer connector

PIN	SIGNAL	TECHNICAL SPECIFICATION	Connector code 345
1	TR	Output signal	
2	VT-	Power supply -15Vdc	
3	VT+	Power supply +15Vdc	
4	GND	Ground	

10 SAFETY REST POSITION - configuration 70

In absence of power supply to the solenoids, the valve main spool is moved by the springs force to the **safety rest position** characterized by a small offset of about 1% to 6% of the total stroke in P-B / A-T configuration. This is specifically designed to avoid that in case of accidental interruption of power supply to the valve solenoids, the actuator moves towards an undefined direction (due to the tolerances of the zero overlap spool), with potential risk of damages or personnel injury.

Thanks to the **safety rest position** the actuator movement is suddenly stopped and it is recovered at very low speed towards the direction corresponding to the P-B/ A-T connection.

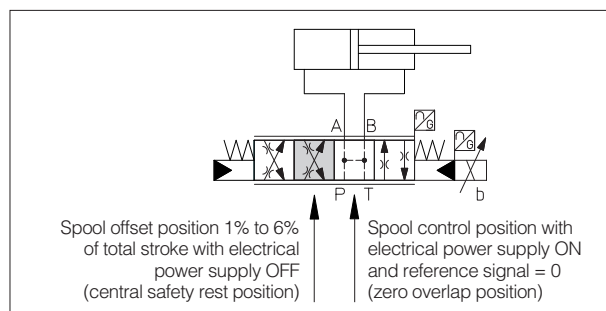

11 FASTENING BOLTS AND SEALS

Type	Size	Fastening bolts	Seals
DPZO	1 = 10	4 socket head screws M6x40 class 12.9 Tightening torque = 15 Nm	5 OR 2050; Diameter of ports A, B, P, T: Ø 11 mm (max) 2 OR 108 Diameter of ports X, Y: Ø = 5 mm (max)
	2 = 16	4 socket head screws M10x50 class 12.9 Tightening torque = 70 Nm 2 socket head screws M6x45 class 12.9 Tightening torque = 15 Nm	4 OR 130; Diameter of ports A, B, P, T: Ø 20 mm (max) 2 OR 2043 Diameter of ports X, Y: Ø = 7 mm (max)
	4 = 25	6 socket head screws M12x60 class 12.9 Tightening torque = 125 Nm	4 OR 4112; Diameter of ports A, B, P, T: Ø 24 mm (max) 2 OR 3056 Diameter of ports X, Y: Ø = 7 mm (max)
	4M = 27	6 socket head screws M12x60 class 12.9 Tightening torque = 125 Nm	4 OR 3137; Diameter of ports A, B, P, T: Ø 32 mm (max) 2 OR 3056 Diameter of ports X, Y: Ø = 7 mm (max)
	6 = 32	6 socket head screws M20x80 class 12.9 Tightening torque = 600 Nm	4 OR 144; Diameter of ports A, B, P, T: Ø 34 mm (max) 2 OR 3056 Diameter of ports X, Y: Ø = 7 mm (max)

12 PLUGS LOCATION FOR PILOT/DRAIN CHANNELS

Depending on the position of internal plugs, different pilot/drain configurations can be obtained as shown below. To modify the pilot/drain configuration, proper plugs must only be interchanged. The plugs have to be sealed using loctite 270. Standard valves configuration provides internal pilot and external drain.

DPZO-1 Pilot channels

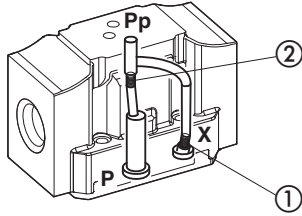

Drain channels

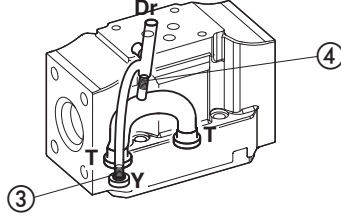

Internal piloting: blinded plug SP-X300F ① in X;
External piloting: blinded plug SP-X300F ② in Pp;
Internal drain: blinded plug SP-X300F ③ in Y;
External drain: blinded plug SP-X300F ④ in Dr.

DPZO-2 Pilot channels

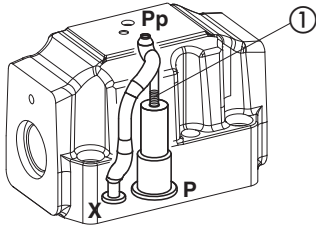

Drain channels

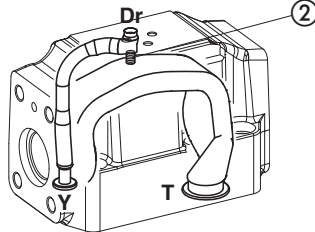

Internal piloting: Without blinded plug SP-X300F ①;
External piloting: Add blinded plug SP-X300F ①;
Internal drain: Without blinded plug SP-X300F ②;
External drain: Add blinded plug SP-X300F ②.

DPZO-4 Pilot channels

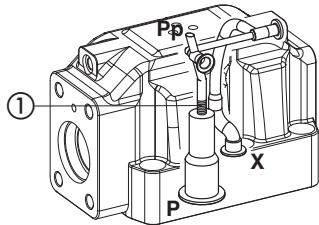

Drain channels

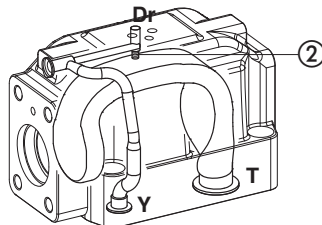

Internal piloting: Without blinded plug SP-X500F ①;
External piloting: Add blinded plug SP-X500F ①;
Internal drain: Without blinded plug SP-X300F ②;
External drain: Add blinded plug SP-X300F ②.

DPZO-6 Pilot channels

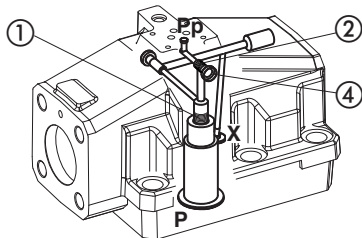

Drain channels

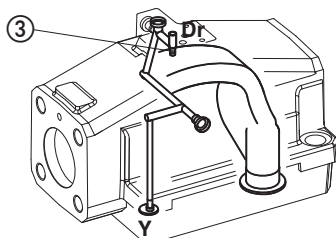

Internal piloting: Without plug ①;
External piloting: Add DIN-908 M16x1,5 in pos ①;
Internal drain: Without blinded plug SP-X300F ③;
External drain: Add blinded plug SP-X300F ③.

13 INSTALLATION DIMENSIONS [mm]

DPZO-L-1

ISO 4401: 2005

Mounting surface: 4401-05-05-0-05 (see table P005)

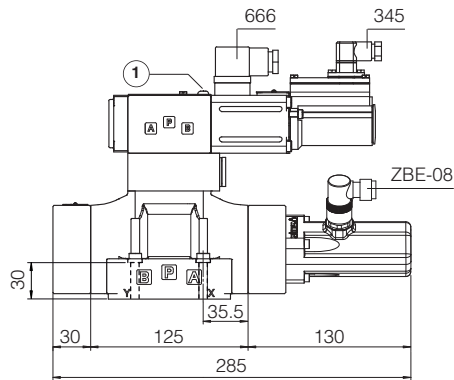

Mass [kg]	
DPZO-L-1	9

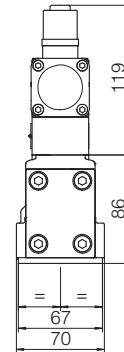

① = Air bleeding 

DPZO-L-2

ISO 4401: 2005

Mounting surface: 4401-07-07-0-05 (see table P005)

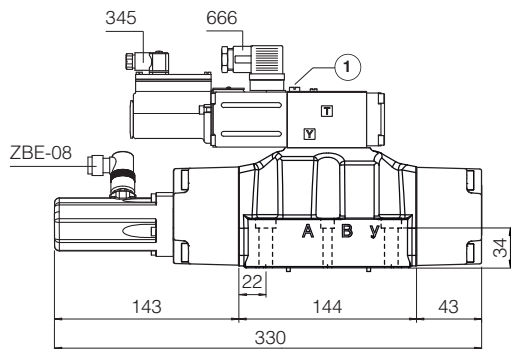

Mass [kg]	
DPZO-L-2	13,5

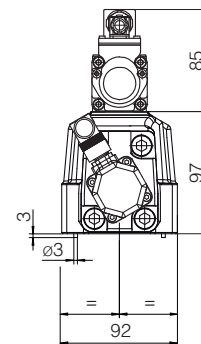

① = Air bleeding 

Notes: the overall height is increased by 40 mm for /G option (0,9 kg);
for option /B the proportional solenoid and the LVDT transducer are at side of port B of the main stage

DPZO-L-4

ISO 4401: 2005

Mounting surface: 4401-08-08-0-05(see table P005)

DPZO-L-4M

ISO 4401: 2005

Mounting surface: 4401-08-08-0-05(see table P005)

ports A, B, P, T \varnothing 32mm

Mass [kg]	
DPZO-L-4*	17,5

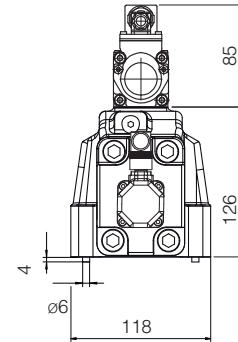
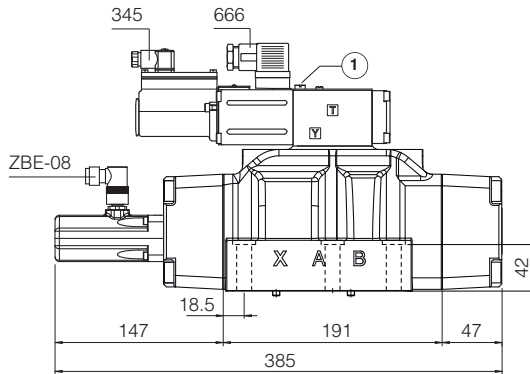

① = Air bleeding 

DPZO-L-6

ISO 4401: 2005

Mounting surface: 4401-10-09-0-05 (see table P005)

Mass [kg]	
DPZO-L-6	42,5

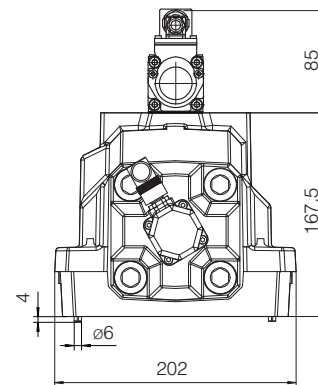
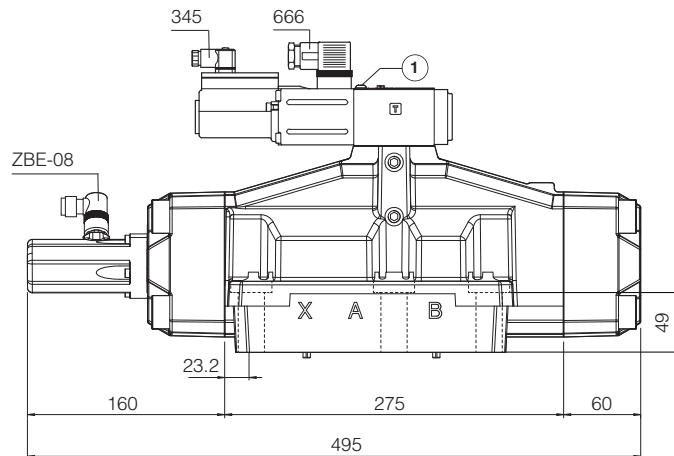

① = Air bleeding 

Notes: the overall height is increased by 40 mm for /G option (0,9 kg);
for option /B the proportional solenoid and the LVDT transducer are at side of port B of the main stage

14 RELATED DOCUMENTATION

FS001	Basics for digital electrohydraulics	GS330	Z-BM-LEZ digital axis card
FS900	Operating and maintenance information for proportional valves	GS500	Programming tools
GS230	E-BM-LEB digital driver	GS510	Fieldbus
GS235	E-BM-LID digital driver	K800	Electric and electronic connectors
GS240	E-BM-LES digital driver	P005	Mounting surfaces for electrohydraulic valves