

# Proportional 2-way cartridges high performance

piloted, with two LVDT transducers, ISO 7368 sizes from 16 to 125

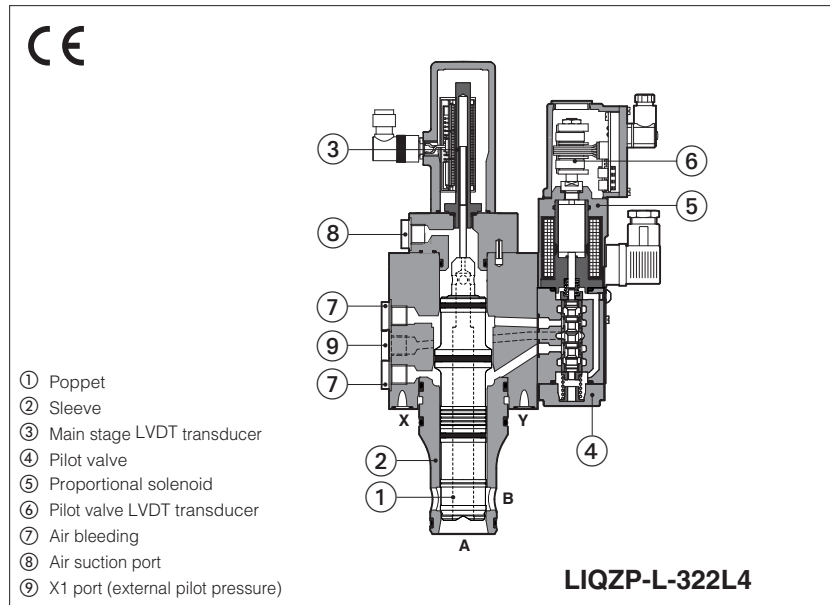

## LIQZP-L

High performance 2-way proportional cartridge valves specifically designed for high speed closed loop controls.

The valves operate in association with digital off-board divers, see section 2.

They are equipped with two LVDT position transducers for best dynamics in not compensated flow regulations.

The cartridge execution for blocks installation grants high flow capabilities and minimized pressure drops.

Spool regulation characteristics: L = linear

**LIQZP:** Size: **16 ÷ 125** - ISO 7368  
 Max flow: **600 ÷ 22000 l/min**  
 Max pressure: **420 bar**

### 1 MODEL CODE

<b>LIQZP</b>	-	<b>L</b>	-	<b>32</b>	<b>2</b>	/	<b>L4</b>	/	<b>*</b>	/	<b>*</b>																					
Proportional 2-way cartridge, piloted																																
L = two LVDT transducers																																
<b>Valve size</b> ISO 7368, see section 4 : <table border="1"> <tr> <td><b>size</b></td> <td><b>16</b></td> <td><b>25</b></td> <td><b>32</b></td> <td><b>40</b></td> </tr> <tr> <td>l/min</td> <td>250</td> <td>500</td> <td>800</td> <td>1200</td> </tr> <tr> <td><b>size</b></td> <td><b>50</b></td> <td><b>63</b></td> <td><b>80</b></td> <td><b>100</b></td> <td><b>125</b></td> </tr> <tr> <td>l/min</td> <td>2000</td> <td>3000</td> <td>4500</td> <td>7200</td> <td>9350</td> </tr> </table> Nominal flow (l/min) at Δp 5 bar											<b>size</b>	<b>16</b>	<b>25</b>	<b>32</b>	<b>40</b>	l/min	250	500	800	1200	<b>size</b>	<b>50</b>	<b>63</b>	<b>80</b>	<b>100</b>	<b>125</b>	l/min	2000	3000	4500	7200	9350
<b>size</b>	<b>16</b>	<b>25</b>	<b>32</b>	<b>40</b>																												
l/min	250	500	800	1200																												
<b>size</b>	<b>50</b>	<b>63</b>	<b>80</b>	<b>100</b>	<b>125</b>																											
l/min	2000	3000	4500	7200	9350																											
<b>Seals material,</b> see section 6 : - = NBR PE = FKM BT = NBR low temperature																																
Series number																																

**Configuration:** 2 = 2 way

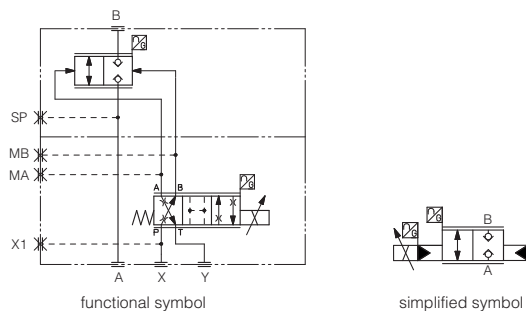

**Spool type, regulating characteristics:**

L4 = linear



## 2 OFF-BOARD ELECTRONIC DRIVERS

Please include in the driver order also the complete code of the connected proportional valve.

Drivers model	E-BM-LEB	E-BM-LES
Type	digital	digital
Format	DIN-rail panel	DIN-rail panel
Tech table	GS230	GS240



### WARNING

To avoid overheating and possible damage of the electronic driver, the valves must be never energized without hydraulic supply to the pilot stage. In case of prolonged pauses of the valve operation during the machine cycle, it is always advisable to disable the driver.

## 3 GENERAL CHARACTERISTICS

Assembly position	Any position
Subplate surface finishing to ISO 4401	Acceptable roughness index: Ra ≤0,8, recommended Ra 0,4 – Flatness ratio 0,01/100
MTTFd valves according to EN ISO 13849	75 years, for further details see technical table P007
Ambient temperature range	<b>Standard</b> = -20°C ÷ +60°C <b>/PE option</b> = -20°C ÷ +60°C <b>/BT option</b> = -40°C ÷ +60°C
Storage temperature range	<b>Standard</b> = -20°C ÷ +70°C <b>/PE option</b> = -20°C ÷ +70°C <b>/BT option</b> = -40°C ÷ +70°C
Surface protection	Zinc coating with black passivation, galvanic treatment (driver housing)
Corrosion resistance	Salt spray test (EN ISO 9227) > 200 h
Vibration resistance	See technical table G004
Compliance	CE according to EMC directive 2014/30/EU (Immunity: EN 61000-6-2; Emission: EN 61000-6-3) RoHS Directive 2011/65/EU as last update by 2015/863/EU REACH Regulation (EC) n°1907/2006

## 4 HYDRAULIC CHARACTERISTICS - based on mineral oil ISO VG 46 at 50 °C

Size	16	25	32	40	50	63	80	100	125
Nominal flow Δp A-B [l/min]									
Δp = 5 bar	250	500	800	1200	2000	3000	4500	7200	9350
Δp = 10 bar	350	700	1100	1700	2800	4250	6350	10200	13200
Max permissible flow	600	1200	1800	2500	4000	6000	10000	16000	22000
Max pressure [bar]	Ports A, B = <b>420</b> X = 350    Y ≤ 10								
Nominal flow of pilot valve at Δp = 70 bar [l/min]	4	8	20	40	40	100	100	100	100
Leakage of pilot valve at P = 100 bar [l/min]	0,2	0,2	0,3	0,7	0,7	1	1	1	1
Piloting pressure [bar]	min: 40% of system pressure    max 350    recommended 140 ÷ 160								
Piloting volume [cm³]	1,6	2,2	7,0	9,4	17,7	32,5	39,5	49,5	124,9
Piloting flow <b>(1)</b> [l/min]	4	5,3	14	19	35,5	56	60	60	88,1
Response time 0 ÷ 100% step signal <b>(2)</b> [ms]	24	25	28	30	30	35	40	50	90
Hysteresis [% of the max regulation]	≤ 0,1								
Repeatability [% of the max regulation]	± 0,1								
Thermal drift	zero point displacement < 1% at ΔT = 40°C								

**(1)** With step reference input 0÷100%

**(2)** With pilot pressure = 140 bar, see detailed diagrams in section 7.2



### WARNING

The loss of the pilot pressure causes the undefined position of the main spool.

The sudden interruption of the power supply during the valve operation causes the immediate shut-off of the main poppet.

This could cause pressure surges in the hydraulic system or high decelerations which may lead to machine damages.

## 5 ELECTRICAL CHARACTERISTICS

Max power consumption	30 W
Max. solenoid current	2,6 A
Coil resistance R at 20°C	3 ÷ 3,3 Ω
Insulation class	H (180°) Due to the occurring surface temperatures of the solenoid coils, the European standards ISO 13732-1 and EN982 must be taken into account
Protection degree to DIN EN60529	IP65 with mating connectors
Duty factor	Continuous rating (ED=100%)

**6 SEALS AND HYDRAULIC FLUIDS** - for other fluids not included in below table, consult our technical office

Seals, recommended fluid temperature	NBR seals (standard) = -20°C ÷ +60°C, with HFC hydraulic fluids = -20°C ÷ +50°C FKM seals (/PE option) = -20°C ÷ +80°C NBR low temp. seals (/BT option) = -40°C ÷ +60°C, with HFC hydraulic fluids = -20°C ÷ +50°C		
Recommended viscosity	20 ÷ 100 mm <sup>2</sup> /s - max allowed range 15 ÷ 380 mm <sup>2</sup> /s		
Max fluid contamination level	normal operation	ISO4406 class 18/16/13 NAS1638 class 7	see also filter section at <a href="http://www.atos.com">www.atos.com</a> or KTF catalog
	longer life	ISO4406 class 16/14/11 NAS1638 class 5	
<b>Hydraulic fluid</b>	<b>Suitable seals type</b>	<b>Classification</b>	<b>Ref. Standard</b>
Mineral oils	NBR, FKM, NBR low temp.	HL, HLP, HLPD, HVLP, HVLPD	DIN 51524
Flame resistant without water	FKM	HFDU, HFDR	ISO 12922
Flame resistant with water	NBR, NBR low temp.	HFC	

**7 DIAGRAMS** (based on mineral oil ISO VG 46 at 50 °C)

**7.1 Regulation diagrams** (values measured at Dp 5 bar)

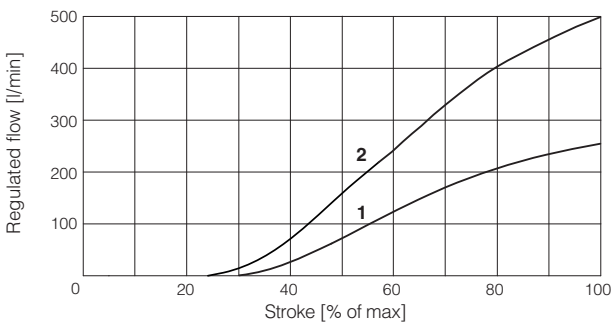

**1** = LIQZP-L-162L4  
**2** = LIQZP-L-252L4

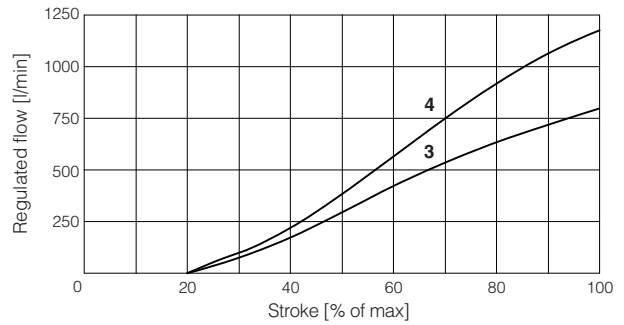

**3** = LIQZP-L-322L4  
**4** = LIQZP-L-402L4

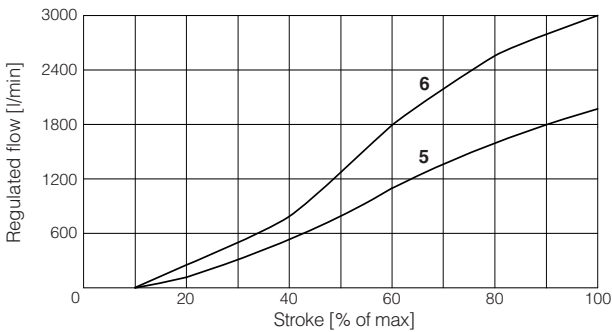

**5** = LIQZP-L-502L4  
**6** = LIQZP-L-632L4

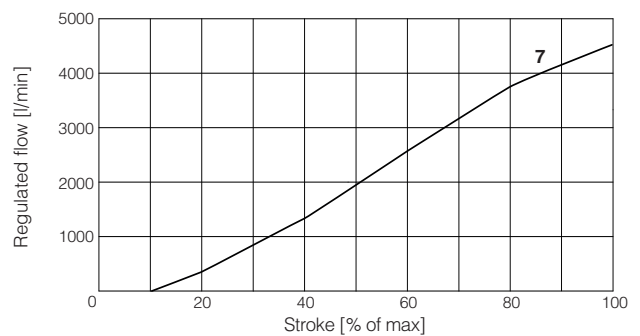

**7** = LIQZP-L-802L4

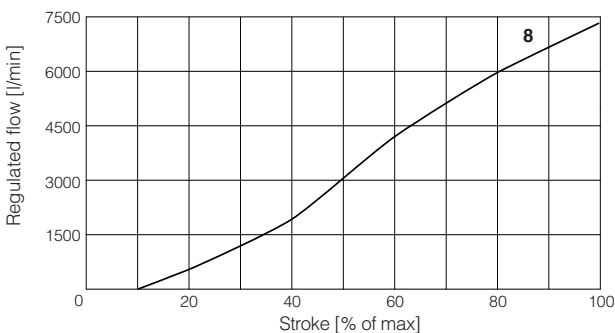

**8** = LIQZP-L-1002L4

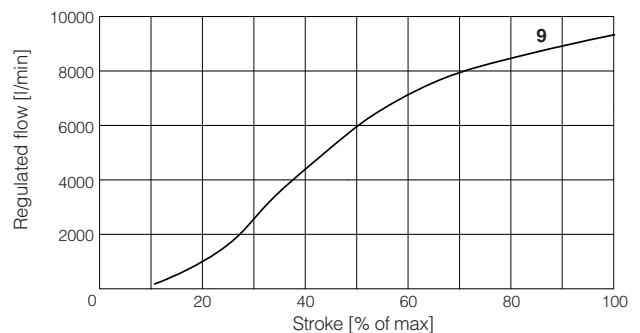

**9** = LIQZP-L-1252L4

## 7.2 Response time

The response times in below diagrams are measured at different steps of the reference input signal. They have to be considered as average values. For the valves with digital electronics the dynamics performances can be optimized by setting the internal software parameters.

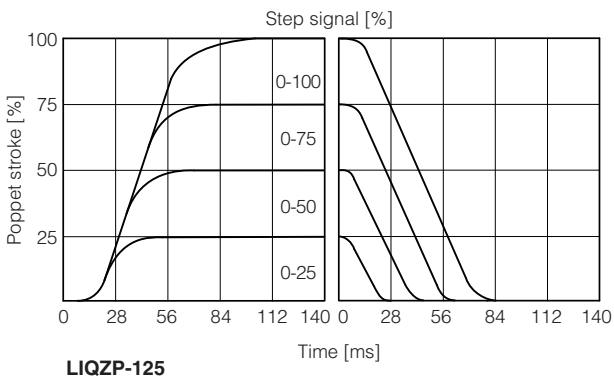
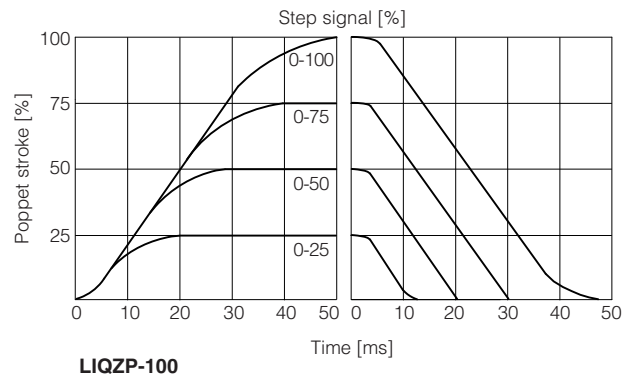
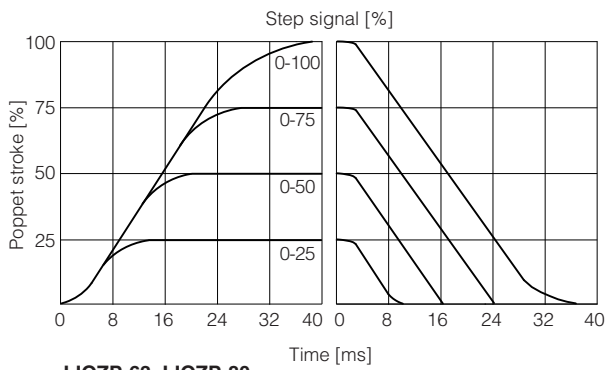
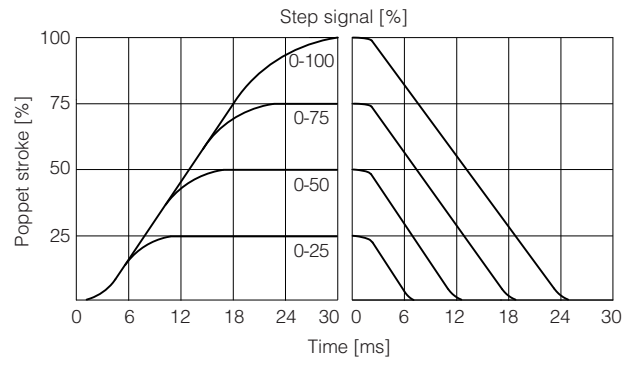
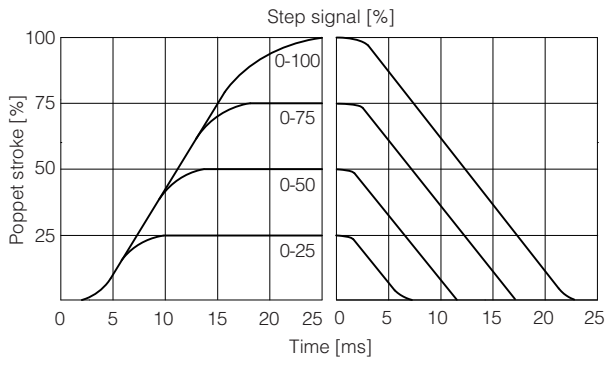

**7.3 Bode diagrams** - stated at nominal hydraulic conditions

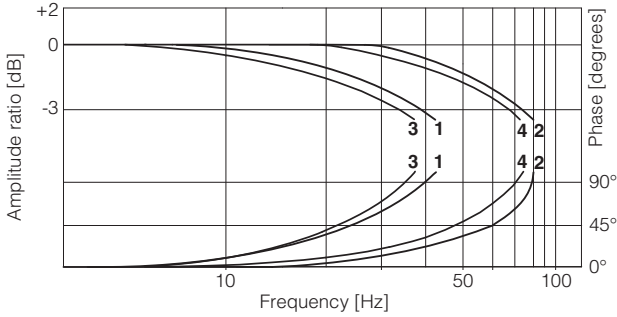

- 1 = LIQZP-L-162L4: 10% ↔ 90%
- 2 = LIQZP-L-162L4: 50% ± 5%
- 3 = LIQZP-L-252L4: 10% ↔ 90%
- 4 = LIQZP-L-252L4: 50% ± 5%

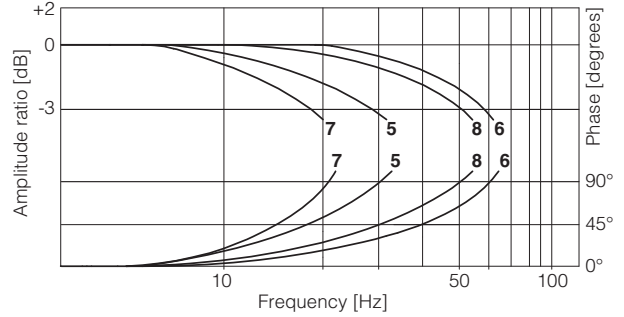

- 5 = LIQZP-L-322L4: 10% ↔ 90%
- 6 = LIQZP-L-322L4: 50% ± 5%
- 7 = LIQZP-L-402L4: 10% ↔ 90%
- 8 = LIQZP-L-402L4: 50% ± 5%

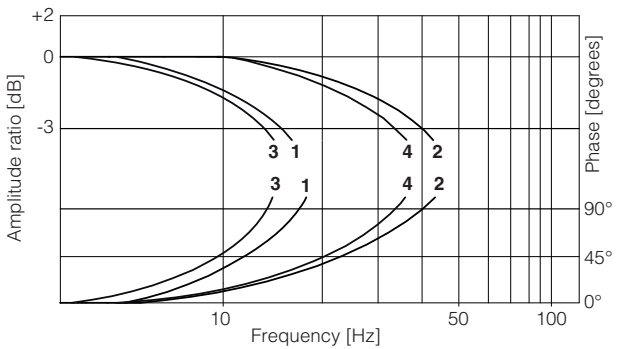

- 1 = LIQZP-L-502L4: 10% ↔ 90%
- 2 = LIQZP-L-502L4: 50% ± 5%
- 3 = LIQZP-L-632L4: 10% ↔ 90%
- 4 = LIQZP-L-632L4: 50% ± 5%

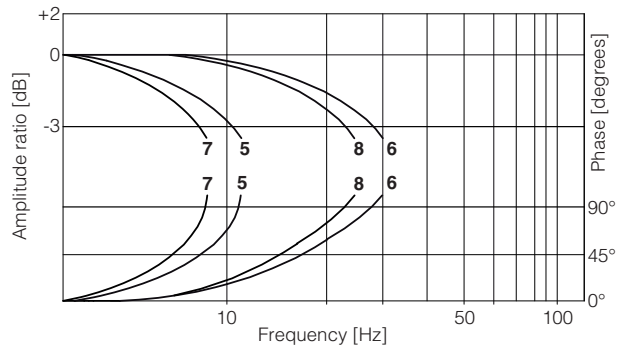

- 5 = LIQZP-L-802L4: 10% ↔ 90%
- 6 = LIQZP-L-802L4: 50% ± 5%
- 7 = LIQZP-L-1002L4: 10% ↔ 90%, LIQZP-L-1252L4: 50% ± 5%
- 8 = LIQZP-L-1002L4: 50% ± 5%
- 9 = LIQZP-L-1252L4: 50% ± 5%

**8 ELECTRICAL CONNECTION** - connectors supplied with the valve

**8.1 Solenoid connector**

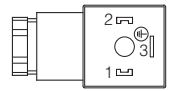
PIN	SIGNAL	TECHNICAL SPECIFICATION	<b>Connector code 666</b> 
1	COIL	Power supply	
2	COIL	Power supply	
3	GND	Ground	

**8.2 LVDT pilot transducer connector**

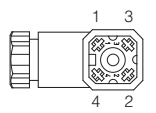
PIN	SIGNAL	TECHNICAL SPECIFICATION	<b>Connector code 345</b> 
1	TR	Output signal	
2	VT-	Power supply -15Vdc	
3	VT+	Power supply +15Vdc	
4	GND	Ground	

**8.3 LVDT main stage transducer connector** - for size 16 ÷ 100

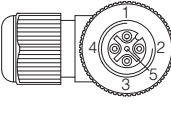
PIN	SIGNAL	TECHNICAL SPECIFICATION	<b>Connector code ZBE-08</b> 
1	PROG	Do not connect	
2	VT+	Power supply +15Vdc	
3	AGND	Ground	
4	TR	Output signal	
5	VT-	Power supply -15Vdc	

**8.4 LVDT main stage transducer connector** - for size 125

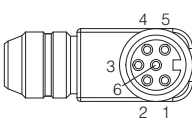
PIN	SIGNAL	TECHNICAL SPECIFICATION	<b>Connector code STCO9131-6-PG9</b> 
1	TR	Output signal	
2	AGND	Ground	
3	NC	Do not connect	
4	NC	Do not connect	
5	VT+	Power supply 24Vdc	
6	VT-	Power supply 0Vdc	

**9 AIR BLEEDING**

**Size 16 and 25**

**Size 32 to 50**

**Size 63 to 125**

**1 Air suction port (SP):**  
 N° 1 plug G1/4" for sizes 16 to 50  
 N° 1 plug G1/2" for sizes 63 to 100  
 N° 1 plug G1" for size 125  
 To be used only in case port A is connected to tank and subjected to negative pressure, consult our technical office.

**2 Air bleeding (MA, MB) and external pilot pressure (X1):**  
 N° 3 plugs G1/4" for sizes 16 to 100  
 N° 3 plugs G3/8" for size 125  
 At the machine commissioning it is advisable to bleed the air from piloting chambers, by loosening the 2 plugs shown in the picture.  
 Operate the valve for few seconds at low pressure and then lock the plugs.

**3 External pilot pressure (X1):**  
 N° 1 plugs G1/4" for sizes 16 to 100  
 N° 1 plugs G3/8" for size 125

**10 FASTENING BOLTS AND VALVE MASS**

Type	Size	Fastening bolts (1)	Mass [kg]
LIQZP	16	4 socket head screws M8x90 class 12.9 Tightening torque = 35 Nm	5,6
	25	4 socket head screws M12x100 class 12.9 Tightening torque = 125 Nm	8,2
	32	4 socket head screws M16x60 class 12.9 Tightening torque = 300 Nm	10,9
	40	4 socket head screws M20x70 class 12.9 Tightening torque = 600 Nm	16,7
	50	4 socket head screws M20x80 class 12.9 Tightening torque = 600 Nm	23,9
	63	4 socket head screws M30x120 class 12.9 Tightening torque = 2100 Nm	44,0
	80	8 socket head screws M24x80 class 12.9 Tightening torque = 1000 Nm	71,6
	100	8 socket head screws M30x120 class 12.9 Tightening torque = 2100 Nm	122,5
	125	8 socket head screws M36x260 class 12.9 Tightening torque = 3600 Nm	375

(1) Fastening bolts supplied with the valve

11 INSTALLATION DIMENSIONS [mm]

LIQZP-L-162

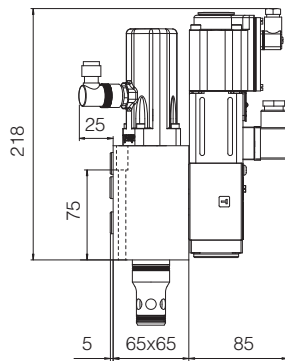

LIQZP-L-252

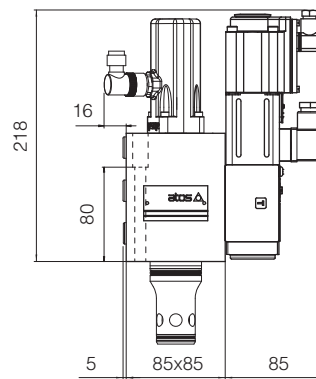

LIQZP-L-322

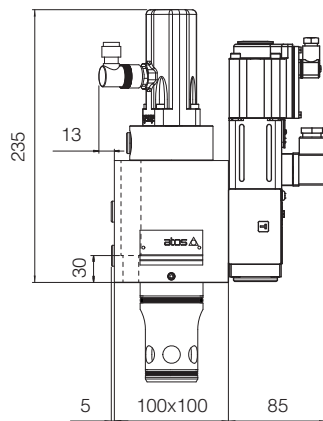

LIQZP-L-402

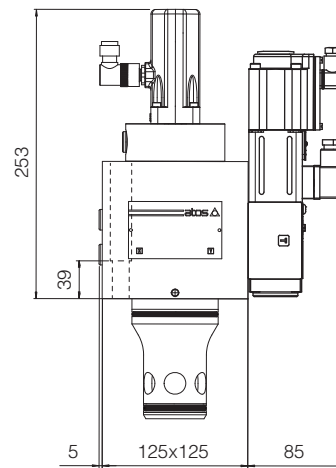

LIQZP-L-502

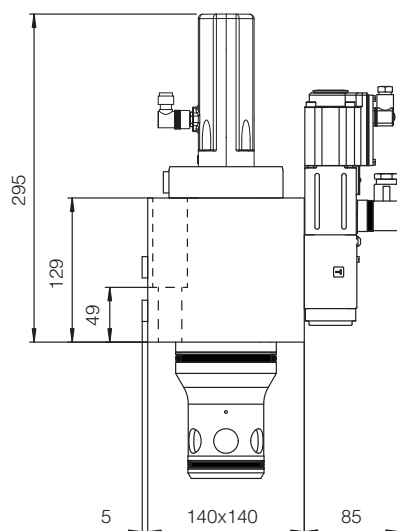

LIQZP-L-632

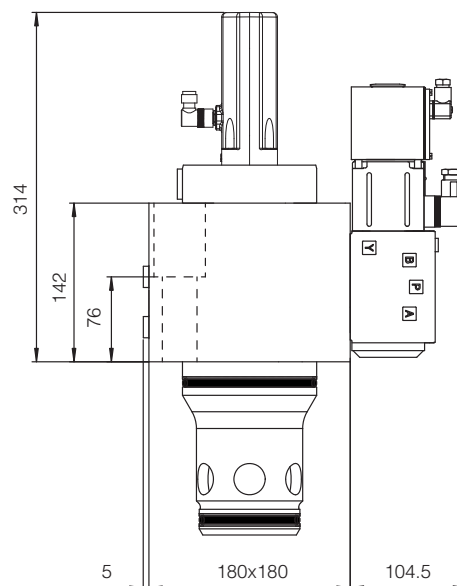

Note: for mounting surface and cavity dimensions, see table P006

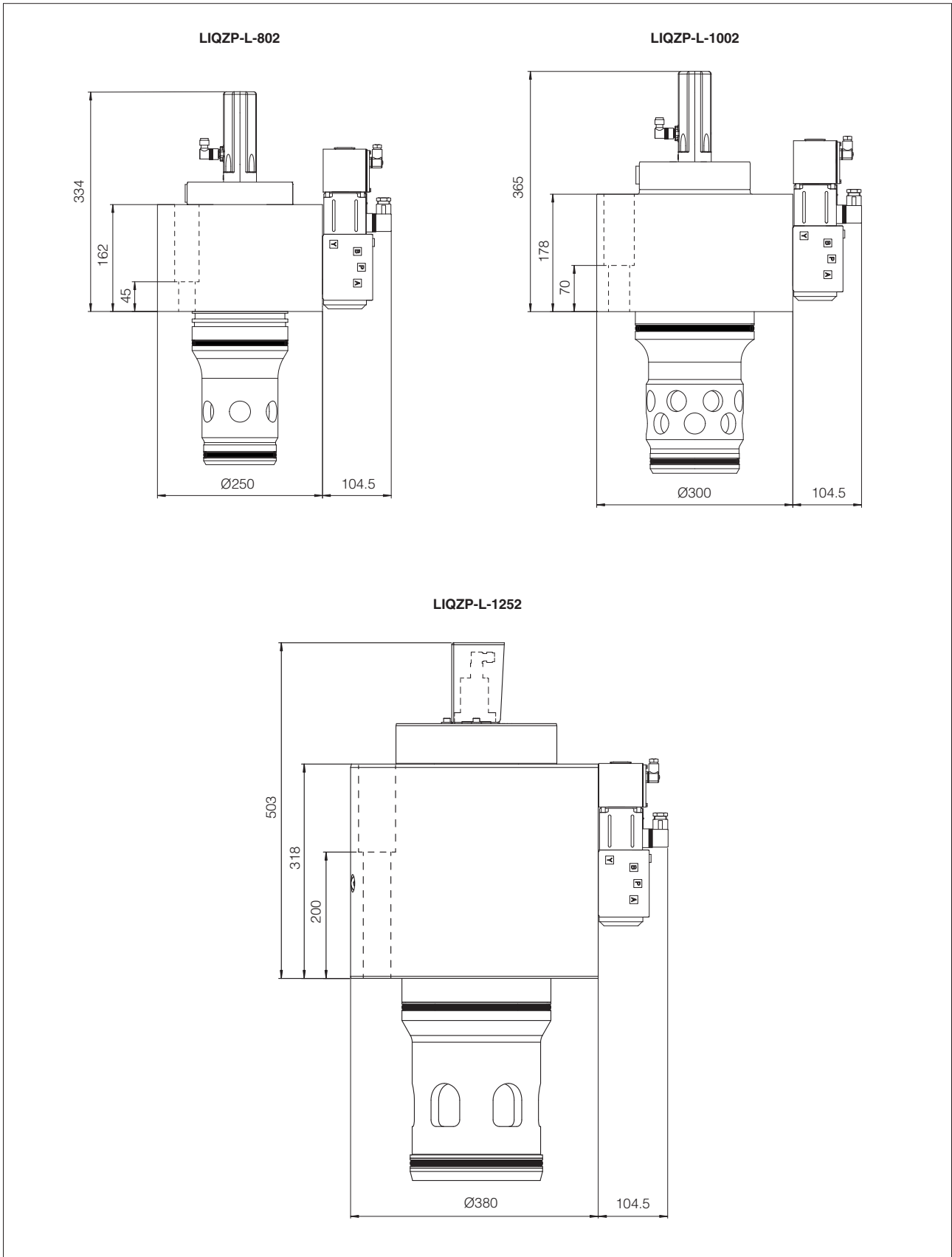

**Note:** for mounting surface and cavity dimensions, see table P006

## 12 RELATED DOCUMENTATION

<b>FS001</b>	Basics for digital electrohydraulics	<b>GS500</b>	Programming tools
<b>FS900</b>	Operating and maintenance information for proportional valves	<b>GS510</b>	Fieldbus
<b>GS230</b>	E-BM-LEB digital driver	<b>K800</b>	Electric and electronic connectors
<b>GS240</b>	E-BM-LES digital driver	<b>P006</b>	Mounting surfaces and cavities for cartridge valves