

# Digital proportional relief valves high performance

piloted, with on-board pressure transducer

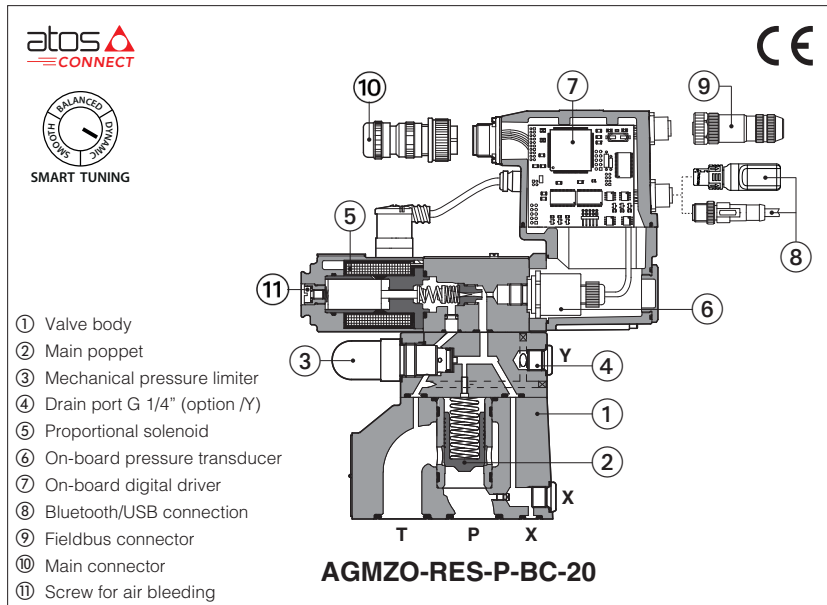

## AGMZO-R, AGMZO-REB, AGMZO-RES

Poppet type, piloted, digital proportional relief valves with on-board pressure transducer for pressure closed loop controls.

**R** to be coupled with off-board driver.

**REB** basic execution, with on-board digital driver, with analog reference signal or IO-Link interface for digital reference signals, valve settings, and real-time diagnostics.

**RES** full execution, with on-board digital driver which includes also fieldbus interfaces for digital reference signals, valve settings, and real-time diagnostics.

For **REB** and **RES**, Bluetooth/USB connection is always present for valve settings via mobile App and Atos PC software.

Size: **10, 20, 32** - ISO 6264  
 Max flow: **200, 400, 600 l/min**  
 Max pressure: **350 bar**

### 1 MODEL CODE

<b>AGMZO</b>	-	<b>RES</b>	-	<b>P</b>	-	<b>BC</b>	-	<b>10</b>	/	<b>315</b>	/	*	/	*	/	*	/	*	
Proportional pressure relief valve, piloted																		<b>Seals material,</b> see section [13]: - = NBR PE = FKM BT = NBR low temp.	
<b>R</b> = off-board driver, see section [3] <b>REB</b> = basic on-board digital driver <b>RES</b> = full on-board digital driver																		<b>Bluetooth option,</b> only for <b>REB</b> and <b>RES (1)</b> , see section [6]: <b>T</b> = Bluetooth adapter supplied with the valve	
<b>P</b> = with on-board pressure transducer																		<b>Hydraulic options (1):</b> <b>E</b> = external pilot <b>Y</b> = external drain (only pipe connection G 1/4")	
<b>IO-Link interface,</b> only for <b>REB</b> , see section [8]: <b>NP</b> = Not present <b>IL</b> = IO-Link																		<b>Electronic options,</b> only for <b>REB-NP</b> and <b>RES (1)</b> : <b>I</b> = current reference input and monitor 4 ÷ 20 mA <b>Q</b> = enable signal <b>Z</b> = double power supply, enable, fault and monitor signals - 12 pin connector	
<b>Fieldbus interfaces,</b> only for <b>RES</b> , see section [9]: <b>BC</b> = CANopen <b>EH</b> = EtherCAT <b>BP</b> = PROFIBUS DP																			
<b>Valve size ISO 6264:</b> <b>10, 20, 32</b>																		<b>Max regulated pressure:</b> <b>100</b> = 100 bar <b>315</b> = 315 bar <b>210</b> = 210 bar <b>350</b> = 350 bar	

(1) For possible combined options, see section [17]

### 2 HYDRAULIC SYMBOLS

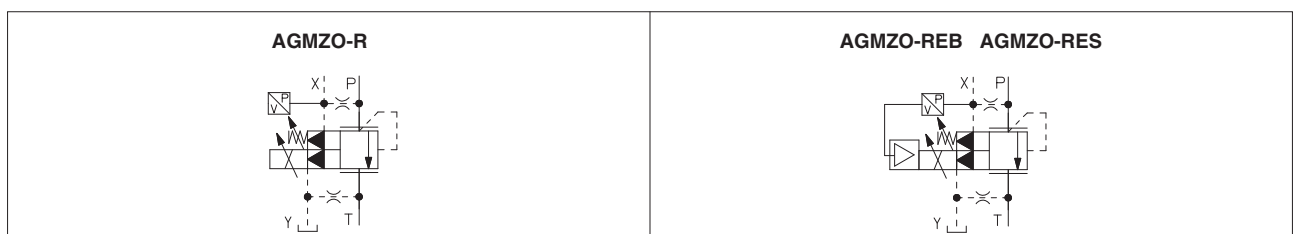

**3 OFF-BOARD ELECTRONIC DRIVER - only for R**

Drivers model	E-BM-RES
Type	Digital
Format	DIN rail panel format
Tech table	GS203

**4 GENERAL NOTES**

Atos digital proportionals valves are CE marked according to the applicable directives (e.g. Immunity and Emission EMC Directive). Installation, wirings and start-up procedures must be performed according to the general prescriptions shown in tech table **FS900** and in the user manuals included in the E-SW-SETUP programming software.

**5 VALVE SETTINGS AND PROGRAMMING TOOLS - see tech. table GS500**

**5.1 Atos CONNECT mobile App**

Free downloadable App for smartphones and tablets which allows quick access to valve main functional parameters and basic diagnostic information via Bluetooth, thus avoiding physical cable connection and significantly reducing commissioning time. Atos CONNECT supports Atos digital valve drivers equipped with E-A-BTH adapter or with built-in Bluetooth. It does not support valves with p/Q control or axis controls.



**5.2 E-SW-SETUP PC software**

Free downloadable software for PC allows to set all valve functional parameters and to access complete diagnostic information of digital valve drivers via Bluetooth/USB service port. Atos E-SW-SETUP PC software supports all Atos digital valve drivers and it is available at [www.atos.com](http://www.atos.com) in MyAtos area.

**WARNING: drivers USB port is not isolated!** For E-C-SB-USB/M12 cable, the use of E-A-SB-USB/OPT isolator adapter is highly recommended for PC protection

**Bluetooth or USB connection**

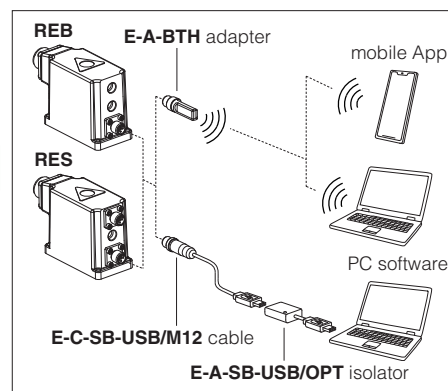

**6 BLUETOOTH OPTION - see tech. table GS500**

T option adds Bluetooth® connectivity to Atos valve drivers thanks to E-A-BTH adapter, which can be left permanently installed on-board, to allow the Bluetooth connection with the valve drivers at any time. E-A-BTH adapter can also be purchased separately and used to connect with any supported Atos digital product.

Bluetooth connection to the valve can be protected against unauthorised access by setting a personal password. The adapter leds visually indicates the status of valve driver and Bluetooth connection.

**WARNING:** for the list of countries where the Bluetooth adapter has been approved, see tech. table **GS500**  
T option is not available for the Indian market, so the Bluetooth adapter must be ordered separately.

**7 SMART TUNING**

Smart tuning allows to adjust the valve dynamic response in order to match different hydraulic conditions and performance requirements.

The valve is provided with 3 factory settings for the pressure control:

- **dynamic** fast response time for best dynamic performances. Default factory setting for pressure valves
- **balanced** average response time suitable for major applications
- **smooth** attenuated response time for slow regulation without overshoots

Smart tuning setting can be switched from Dynamic (default) to Balanced or Smooth via software or fieldbus; if requested, performances can be further customized directly tuning each single control parameter. For details consult related manuals E-MAN-\* and Quickstart, see section [27](#).

Below indications have to be considered as a general guideline, being affected by hydraulic circuit stiffness, working flow and dead volume.

**High stiffness - Low flow - Small volume**

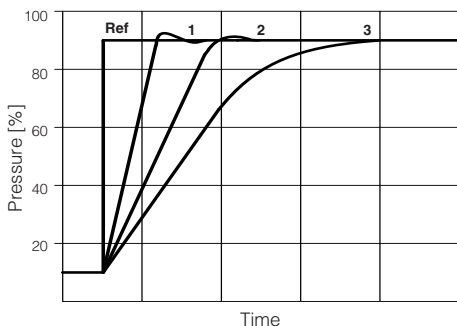

- 1 = dynamic
- 2 = balanced
- 3 = smooth

**Low stiffness - High flow - Large volume**

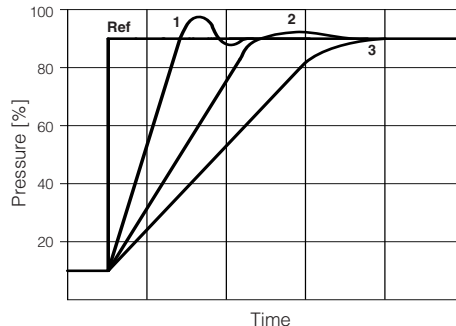

- 1 = dynamic
- 2 = balanced
- 3 = smooth

**8 IO-LINK - only for REB, see tech. table GS520**

IO-Link allows low cost digital communication between the valve and machine central unit. The valve is directly connected to a port of an IO-Link master (point-to-point connection) via low-cost unshielded cables for digital reference, diagnostic and settings. The IO-Link master works as a hub exchanging this information with the machine central unit via fieldbus.

**9 FIELDBUS - only for RES, see tech. table GS510**

Fieldbus allows valve direct communication with machine control unit for digital reference, valve diagnostics and settings. These execution allow to operate the valves through fieldbus or analog signals available on the main connector.

## 10 GENERAL CHARACTERISTICS

Assembly position	Any position
Subplate surface finishing to ISO 4401	Acceptable roughness index: Ra ≤ 0,8, recommended Ra 0,4 – Flatness ratio 0,01/100
MTTFd valves according to EN ISO 13849	75 years, for further details see technical table P007
Ambient temperature range	<b>R:</b> <b>Standard</b> = -20°C ÷ +70°C <b>/PE</b> option = -20°C ÷ +70°C <b>/BT</b> option = -40°C ÷ +60°C <b>REB, RES:</b> <b>Standard</b> = -20°C ÷ +60°C <b>/PE</b> option = -20°C ÷ +60°C <b>/BT</b> option = -40°C ÷ +60°C
Storage temperature range	<b>R:</b> <b>Standard</b> = -20°C ÷ +80°C <b>/PE</b> option = -20°C ÷ +80°C <b>/BT</b> option = -40°C ÷ +70°C <b>REB, RES:</b> <b>Standard</b> = -20°C ÷ +70°C <b>/PE</b> option = -20°C ÷ +70°C <b>/BT</b> option = -40°C ÷ +70°C
Surface protection	Zinc coating with black passivation, galvanic treatment (driver housing for REB and RES)
Corrosion resistance	Salt spray test (EN ISO 9227) > 200 h
Vibration resistance	See technical table G004 (for REB and RES)
Compliance	CE according to EMC directive 2014/30/EU (Immunity: EN 61000-6-2; Emission: EN 61000-6-3) RoHS Directive 2011/65/EU as last update by 2015/863/EU REACH Regulation (EC) n°1907/2006

## 11 HYDRAULIC CHARACTERISTICS - based on mineral oil ISO VG 46 at 50 °C

Valve model	AGMZO*-10	AGMZO*-20	AGMZO*-32
Max regulated pressure [bar]	100; 210; 315; 350		
Max pressure at port P [bar]	350		
Max pressure at port T [bar]	210		
Min regulated pressure [bar]	see min. pressure / flow diagrams at section 14		
Max flow [l/min]	200	400	600
Response time 0-100% step signal (depending on installation) (1) [ms]	≤ 80	≤ 100	≤ 115
Hysteresis	≤ 0,5 [% of max pressure]		
Linearity	≤ 1,0 [% of max pressure]		
Repeatability	≤ 0,2 [% of max pressure]		
Thermal drift	zero point displacement < 1% at ΔT = 40°C		

**Note:** above performance data refer to valves coupled with Atos electronic drivers, see section 3

(1) Average response time value; the pressure variation in consequence of a modification of the reference input signal to the valve is affected by the stiffness of the hydraulic circuit: greater is the stiffness of the circuit, faster is the dynamic response, see section 7

## 12 ELECTRICAL CHARACTERISTICS

Power supplies	Nominal : +24 VDC Rectified and filtered : VRMS = 20 ÷ 32 VMAX (ripple max 10 % VPP)				
Max power consumption	<b>R</b> = 30 W <b>REB, RES</b> = 50 W				
Max. solenoid current	3 A				
Coil resistance R at 20°C	3 ÷ 3,3 Ω				
Analog input signals	Voltage: range ±10 VDC (24 VMAX tolerant) Current: range ±20 mA		Input impedance: Ri > 50 kΩ Input impedance: Ri = 500 Ω		
Monitor output	Voltage: maximum range 0 ÷ 10 Vdc @ max 5 mA Current: maximum range 0 ÷ 20 mA @ max 500 Ω load resistance				
Enable input	Range: 0 ÷ 9 VDC (OFF state), 15 ÷ 24 VDC (ON state), 9 ÷ 15 VDC (not accepted); Input impedance: Ri > 87 kΩ				
Fault output	Output range : 0 ÷ 24 Vdc (ON state ≡ VL+ [logic power supply] ; OFF state ≡ 0 V) @ max 50 mA; external negative voltage not allowed (e.g. due to inductive loads)				
Pressure transducer (1)	E-ATR-8*/I Output signal: 4 ÷ 20 mA (see tech table <b>GS465</b> )				
Alarms	Solenoid not connected/short circuit, cable break with current reference signal, over/under temperature, current control monitoring, power supplies level, pressure transducer failure				
Insulation class	H (180°) Due to the occurring surface temperatures of the solenoid coils, the European standards ISO 13732-1 and EN982 must be taken into account				
Protection degree to DIN EN60529	<b>R</b> = IP65; <b>REB, RES</b> = IP66 / IP67 with mating connectors				
Duty factor	Continuous rating (ED=100%)				
Tropicalization	Tropical coating on electronics PCB				
Additional characteristics	Short circuit protection of solenoid's current supply; current control by P.I.D. with rapid solenoid switching; protection against reverse polarity of power supply				
Communication interface	USB Atos ASCII coding	IO-Link Interface and System Specification 1.1.3	CANopen EN50325-4 + DS408	PROFIBUS DP EN50170-2/IEC61158	EtherCAT IEC 61158
Communication physical layer	not insulated USB 2.0+ USB OTG	SDCI class port B	optical insulated CAN ISO11898	optical insulated RS485	Fast Ethernet, insulated 100 Base TX
Recommended wiring cable	LiYCY shielded cables, see section 24				

(1) In case of pressure transducer failure, the valve's reaction can be configured through Atos E-SW-SETUP software to:

- cut off the current to solenoid, therefore the regulated pressure will be reduced to minimum value (default setting)
- automatically switch the pressure control from closed loop (dynamic, balanced, smooth) to open loop, to let the valve to temporarily operate with reduced regulation accuracy

**Note:** a maximum time of 500 ms (depending on communication type) has to be considered between the driver energizing with the 24 VDC power supply and when the valve is ready to operate. During this time the current to the valve coils is switched to zero.

**13 SEALS AND HYDRAULIC FLUIDS** - for other fluids not included in below table, consult our technical office

Seals, recommended fluid temperature	NBR seals (standard) = -20°C ÷ +60°C (+80°C for <b>R</b> ), with HFC hydraulic fluids = -20°C ÷ +50°C FKM seals (/PE option) = -20°C ÷ +80°C NBR low temp. seals (/BT option) = -40°C ÷ +60°C, with HFC hydraulic fluids = -20°C ÷ +50°C		
Recommended viscosity	20 ÷ 100 mm <sup>2</sup> /s - max allowed range 15 ÷ 380 mm <sup>2</sup> /s		
Max fluid contamination level	normal operation	ISO4406 class 18/16/13	NAS1638 class 7
	longer life	ISO4406 class 16/14/11	NAS1638 class 5
		see also filter section at <a href="http://www.atos.com">www.atos.com</a> or KTF catalog	
Hydraulic fluid	Suitable seals type	Classification	Ref. Standard
Mineral oils	NBR, FKM, NBR low temp.	HL, HLP, HLPD, HVLP, HVLPD	DIN 51524
Flame resistant without water	FKM	HFDU, HFDR	ISO 12922
Flame resistant with water	NBR, NBR low temp.	HFC	

**14 DIAGRAMS** (based on mineral oil ISO VG 46 at 50 °C)

**1 = Regulation diagrams**  
with flow rate Q = 50 l/min

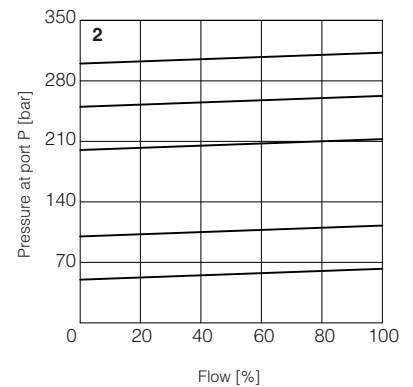
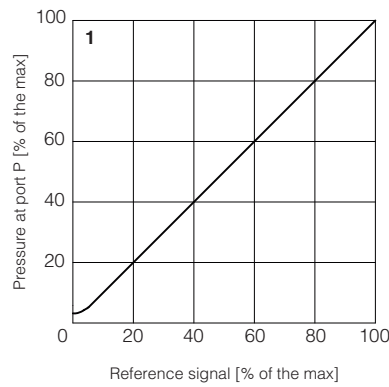

**2 = Pressure/flow diagrams**  
with reference signal set at Q = 50 l/min

**3-8 = Min. pressure/flow diagrams**  
with zero reference signal

- 3 = AGMZO\*-10/100, 210, 315
- 4 = AGMZO\*-10/350
- 5 = AGMZO\*-20/100, 210, 315
- 6 = AGMZO\*-20/350
- 7 = AGMZO\*-32/100, 210, 315
- 8 = AGMZO\*-32/350

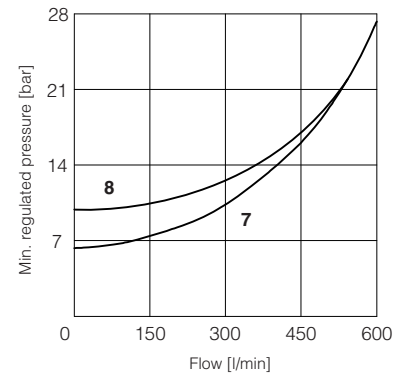
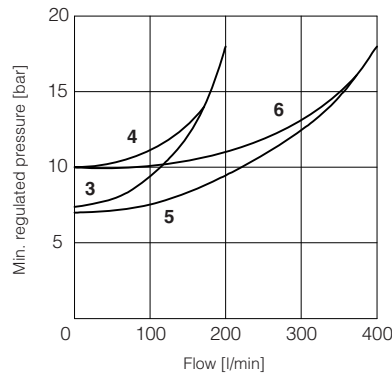

## 15 HYDRAULIC OPTIONS

- E** = External pilot option to be selected when the pilot pressure is supplied from a different line respect to the P main line.  
 With option E the internal connection between port P and X of the valve is plugged.  
 The pilot pressure must be connected to the X port available on the valve's mounting surface or on main body (threaded pipe connection G 1/4").
- Y** = The external drain is mandatory in case the main line T is subjected to pressure peaks or it is pressurized.  
 The Y drain port has a threaded connection G 1/4" available on the pilot stage body.

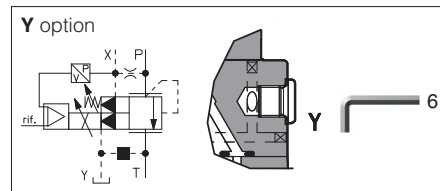
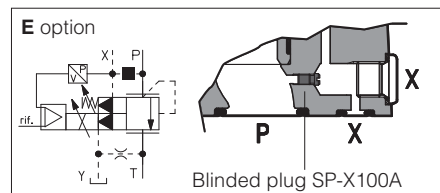

## 16 ELECTRONIC OPTIONS - only for REB-NP and RES

- I** = This option provides 4 ÷ 20 mA current reference and monitor signals, instead of the standard 0 ÷ 10 VDC. Input signal can be reconfigured via software selecting between voltage and current, within a maximum range of ±10 VDC or ±20 mA.  
 It is normally used in case of long distance between the machine control unit and the valve or where the reference signal can be affected by electrical noise; the valve functioning is disabled in case of reference signal cable breakage.
- Q** = This option permits to inhibit the valve function without removing the power supply to the driver. Upon disable command the current to the solenoid is zeroed and the valve's spool moves to rest position.  
 The option /Q is suggested for all cases where the valve has to be frequently inhibited during the machine cycle – see 21.5 for signal specifications.
- Z** = This option provides, on the 12 pin main connector, the following additional features:  
**Fault output signal** - see 21.6  
**Enable input signal** - see above option /Q  
**Power supply for driver's logics and communication** - see 21.2

## 17 POSSIBLE COMBINED OPTIONS

**Hydraulic options:** all combination possible

**Electronic options:** /IQ, /IZ

**Note:** /T Bluetooth adapter option can be combined with all other options

## 18 MECHANICAL PRESSURE LIMITER

The AGMZO are provided with mechanical pressure limiter acting as protection against overpressure. For safety reasons the factory setting of the mechanical pressure limiter is fully unloaded (min pressure). At the first commissioning it must be set at a value lightly higher than the max pressure regulated with the proportional control.

For the pressure setting of the mechanical pressure limiter, proceed according to following steps:

- apply the max reference input signal to the valve's driver. The system pressure will not increase until the mechanical pressure limiter remains unloaded.
- turn clockwise the adjustment screw ① until the system pressure will increase up to a stable value corresponding to the pressure setpoint at max reference input signal.
- turn clockwise the adjustment screw ① of additional 1 or 2 turns to ensure that the mechanical pressure limiter remains closed during the proportional valve working.

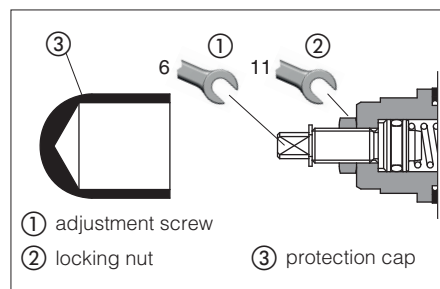

## 19 REMOTE PRESSURE UNLOADING

The P main line can be remotely unloaded by connecting the valve X port to a solenoid valve as shown in the below scheme (venting valve).

This function can be used in emergency to unload the system pressure by-passing the proportional control.

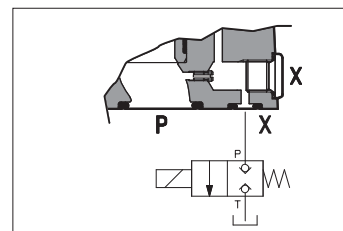

## 20 AIR BLEEDING

At the first valve commissioning the air eventually trapped inside the solenoid must be bled-off through the screw ① located at the rear side of the solenoid housing.

The presence of air may cause pressure instability and vibrations.

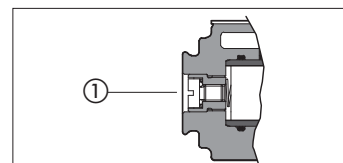

## 21 POWER SUPPLY AND SIGNALS SPECIFICATIONS - only for REB-NP and RES

Generic electrical output signals of the valve (e.g. fault or monitor signals) must not be directly used to activate safety functions, like to switch-ON/OFF the machine's safety components, as prescribed by the European standards (Safety requirements of fluid technology systems and components-hydraulics, ISO 4413).

For REB-IL signals see section 22

### 21.1 Power supply (V+ and V0)

The power supply must be appropriately stabilized or rectified and filtered: apply at least a 10000  $\mu$ F/40 V capacitance to single phase rectifiers or a 4700  $\mu$ F/40 V capacitance to three phase rectifiers. In case of separate power supply see 21.2.



A safety fuse is required in series to each power supply: 2,5 A time lag fuse.

### 21.2 Power supply for driver's logic and communication (VL+ and VL0) - only for /Z option

The power supply for driver's logic and communication must be appropriately stabilized or rectified and filtered: apply at least a 10000  $\mu$ F/40 V capacitance to single phase rectifiers or a 4700  $\mu$ F/40 V capacitance to three phase rectifiers.

The separate power supply for driver's logic on pin 9 and 10, allow to remove solenoid power supply from pin 1 and 2 maintaining active the diagnostics, USB and fieldbus communications.



A safety fuse is required in series to each driver's logic and communication power supply: 500 mA fast fuse.

### 21.3 Pressure reference input signal (P\_INPUT+)

The driver controls in closed loop the current to the valve pressure proportionally to the external reference input signal.

Reference input signal is factory preset according to selected valve code, defaults are 0  $\div$  10 VDC for standard and 4  $\div$  20 mA for /I option.

Input signal can be reconfigured via software selecting between voltage and current, within a maximum range of  $\pm$ 10 VDC or  $\pm$  20 mA.

Drivers with fieldbus interface (BC, BP, EH) can be software set to receive reference signal directly by the machine control unit (fieldbus reference).

Analog reference input signal can be used as on-off commands with input range 0  $\div$  24 VDC.

### 21.4 Pressure monitor output signal (P\_MONITOR)

The driver generates an analog output signal proportional to the actual pressure of the valve; the monitor output signal can be software set to show other signals available in the driver (e.g. analog reference, fieldbus reference).

Monitor output signal is factory preset according to selected valve code, defaults settings are 0  $\div$  10 Vdc for standard and 4  $\div$  20 mA for /I option.

Output signal can be reconfigured via software selecting between voltage and current, within a maximum range of 0  $\div$  10 Vdc or 0  $\div$  20 mA.

### 21.5 Enable input signal (ENABLE) - not for standard

To enable the driver, supply a 24 Vdc on pin 3 (pin C): Enable input signal allows to enable/disable the current supply to the solenoid, without removing the electrical power supply to the driver; it is used to active the communication and the other driver functions when the valve must be disabled for safety reasons. This condition **does not comply** with norms IEC 61508 and ISO 13849.

Enable input signal can be used as generic digital input by software selection.

### 21.6 Fault output signal (FAULT) - only for /Z option

Fault output signal indicates fault conditions of the driver (solenoid short circuits/not connected, reference signal broken for 4  $\div$  20 mA input, etc.).

Fault presence corresponds to 0 VDC, normal working corresponds to 24 VDC. Fault status is not affected by the Enable input signal.

## 22 IO-LINK SIGNALS SPECIFICATIONS - only for REB-IL

### 22.1 Power supply for IO-Link communication (L+ and L-)

The IO-Link master provides dedicated 24 Vdc power supply for IO-Link communication.

Maximum power consumption: 2 W

Internal electrical isolation of power L+, L- from P24, N24

### 22.2 Power supply for driver's logic and valve regulation (P24 and N24)

The IO-Link master provides dedicated 24 Vdc power supply for valve regulation, logics and diagnostics.

Maximum power consumption: 50 W

Internal electrical isolation of power P24, N24 from L+, L-

### 22.3 IO-Link data line (C/Q)

C/Q signal is used to establish communication between IO-Link master and valve.

## 23 ELECTRONIC CONNECTIONS

### 23.1 Main connector signals - 7 pin (A1) Standard and /Q option - for REB-NP and RES

PIN	Standard	/Q	TECHNICAL SPECIFICATIONS	NOTES
A	V+		Power supply 24 Vdc	Input - power supply
B	V0		Power supply 0 Vdc	Gnd - power supply
C	AGND		Analog ground	Gnd - analog signal
		ENABLE	Enable (24 Vdc) or disable (0 Vdc) the driver, referred to V0	Input - on/off signal
D	P_INPUT+		Pressure reference input signal: $\pm 10$ Vdc / $\pm 20$ mA maximum range Defaults are 0 $\div$ 10 Vdc for standard and 4 $\div$ 20 mA for /I option	Input - analog signal <b>Software selectable</b>
E	INPUT-		Negative reference input signal for P_INPUT+	Input - analog signal
F	P_MONITOR referred to: AGND   V0		Pressure monitor output signal: 0 $\div$ 10 Vdc / 0 $\div$ 20 mA maximum range Defaults are 0 $\div$ 10 Vdc for standard and 4 $\div$ 20 mA for /I option	Output - analog signal <b>Software selectable</b>
G	EARTH		Internally connected to driver housing	

### 23.2 Main connector signals - 12 pin (A2) /Z option - for REB-NP and RES

PIN	/Z	TECHNICAL SPECIFICATIONS	NOTES
1	V+	Power supply 24 Vdc	Input - power supply
2	V0	Power supply 0 Vdc	Gnd - power supply
3	ENABLE	Enable (24 Vdc) or disable (0 Vdc) the driver, referred to V0	Input - on/off signal
4	P_INPUT+	Pressure reference input signal: $\pm 10$ Vdc / $\pm 20$ mA maximum range Defaults are 0 $\div$ 10 Vdc for standard and 4 $\div$ 20 mA for /I option	Input - analog signal <b>Software selectable</b>
5	INPUT-	Negative reference input signal for INPUT+	Input - analog signal
6	P_MONITOR	Pressure monitor output signal: 0 $\div$ 10 Vdc / 0 $\div$ 20 mA maximum range, referred to V0 Defaults are 0 $\div$ 10 Vdc for standard and 4 $\div$ 20 mA for /I option	Output - analog signal <b>Software selectable</b>
7	NC	Do not connect	
8	NC	Do not connect	
9	VL+	Power supply 24 Vdc for driver's logic and communication	Input - power supply
10	V0	Power supply 0 Vdc for driver's logic and communication	Gnd - power supply
11	FAULT	Fault (0 Vdc) or normal working (24 Vdc), referred to V0	Output - on/off signal
PE	EARTH	Internally connected to driver housing	

**Note:** do not disconnect V0 before VL+ when the driver is connected to PC USB port

### 23.3 IO-Link connector signals - M12 - 5 pin - Coding A, port class B (A) only for REB-IL

PIN	SIGNAL	TECHNICAL SPECIFICATIONS	NOTES
1	L+	Power supply 24 Vdc for IO-Link communication	Input - power supply
2	P24	Power supply 24 Vdc for valve regulation, logics and diagnostics	Input - power supply
3	L-	Power supply 0 Vdc for IO-Link communication	Gnd - power supply
4	C/Q	IO-Link data line	Input / Output - signal
5	N24	Power supply 0 Vdc for valve regulation, logics and diagnostics	Gnd - power supply

**Note:** L+, L- and P24, N24 are electrically isolated

### 23.4 Communication connectors - for REB (B) and RES (B) - (C)

(B) USB connector - M12 - 5 pin always present		
PIN	SIGNAL	TECHNICAL SPECIFICATION (1)
1	+5V_USB	Power supply
2	ID	Identification
3	GND_USB	Signal zero data line
4	D-	Data line -
5	D+	Data line +

(C2) BP fieldbus execution, connector - M12 - 5 pin (2)		
PIN	SIGNAL	TECHNICAL SPECIFICATION (1)
1	+5V	Termination supply signal
2	LINE-A	Bus line (high)
3	DGND	Data line and termination signal zero
4	LINE-B	Bus line (low)
5	SHIELD	

(1) Shield connection on connector's housing is recommended

(C1) BC fieldbus execution, connector - M12 - 5 pin (2)		
PIN	SIGNAL	TECHNICAL SPECIFICATION (1)
1	CAN_SHLD	Shield
2	NC	do not connect
3	CAN_GND	Signal zero data line
4	CAN_H	Bus line (high)
5	CAN_L	Bus line (low)

(C3) (C4) EH fieldbus execution, connector - M12 - 4 pin (2)		
PIN	SIGNAL	TECHNICAL SPECIFICATION (1)
1	TX+	Transmitter
2	RX+	Receiver
3	TX-	Transmitter
4	RX-	Receiver
Housing	SHIELD	

(2) Only for RES execution

### 23.5 Solenoid connection - only for R

PIN	SIGNAL	TECHNICAL SPECIFICATION	Connector code 666
1	COIL	Power supply	
2	COIL	Power supply	
3	GND	Ground	

### 23.6 Pressure transducer connection - only for R

PIN	SIGNAL	TECHNICAL SPECIFICATION	Connector code ZBE-08
1	V+	Power supply	
2	NC	Not connected	
3	TR	Output signal 4 $\div$ 20 mA	
4	NC	Not connected	
5	NC	Not connected	

### 23.7 REB-NP connections layout

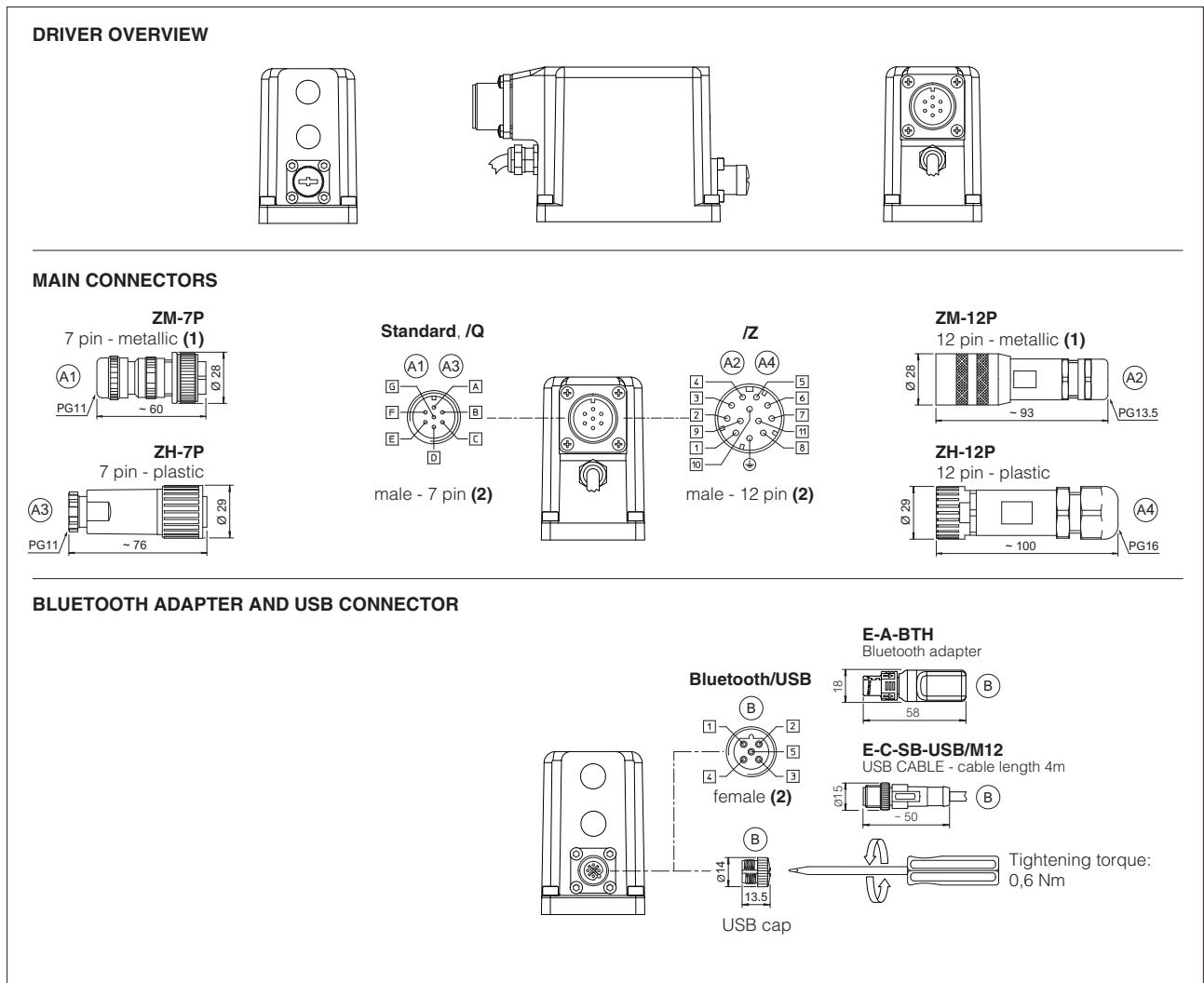

(1) Use of metallic connectors is strongly recommended in order to fulfill EMC requirements (2) Pin layout always referred to driver's view

### 23.8 REB-IL connections layout

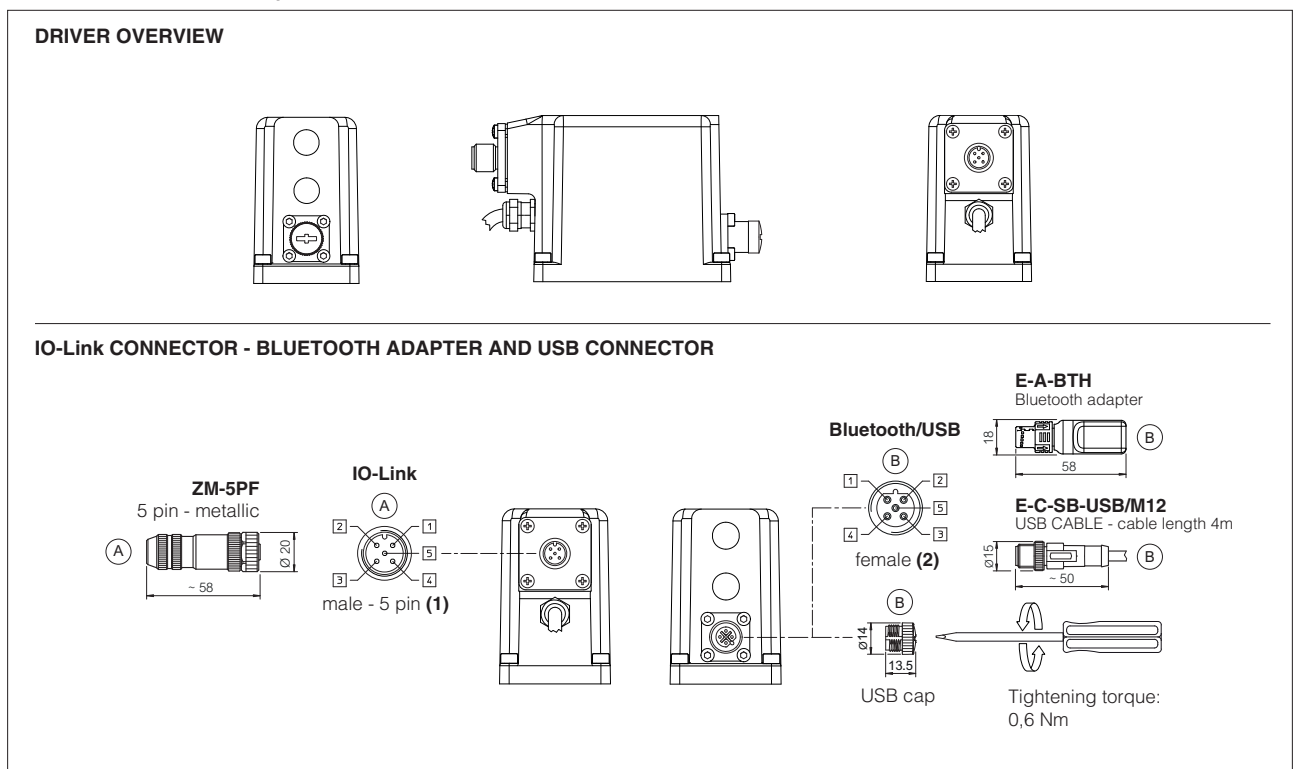

(1) Use of metallic connectors is strongly recommended in order to fulfill EMC requirements (2) Pin layout always referred to driver's view



## 23.9 RES connections layout

### DRIVER OVERVIEW

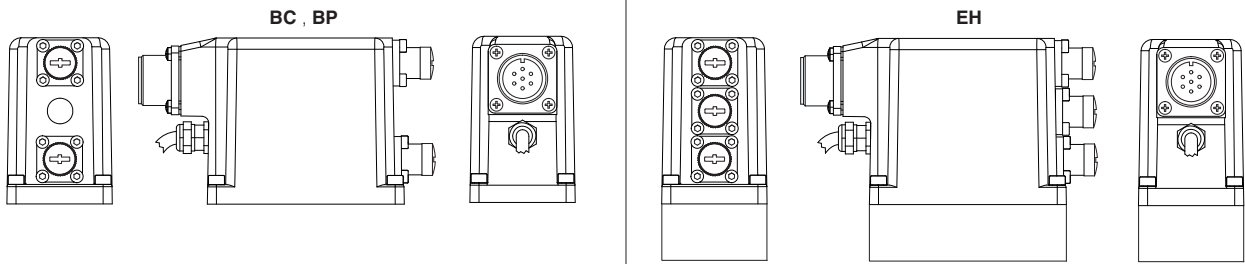

### MAIN CONNECTORS

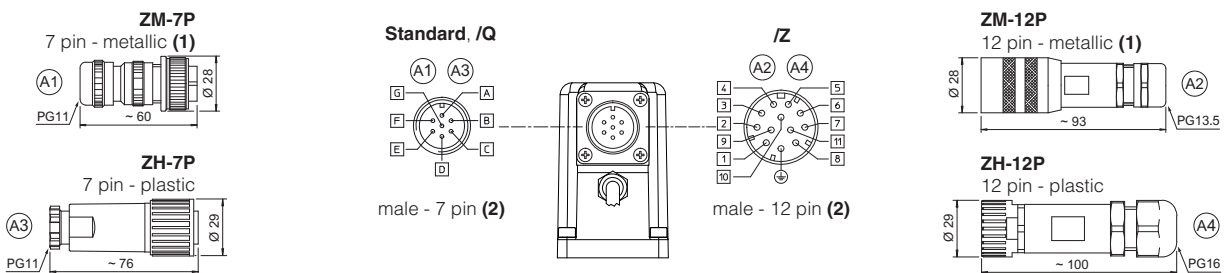

### FIELDBUS CONNECTORS

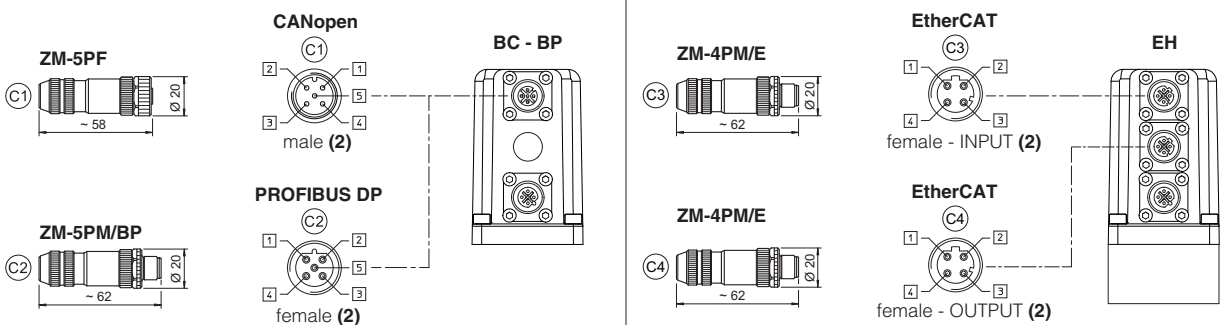

### BLUETOOTH ADAPTER AND USB CONNECTOR

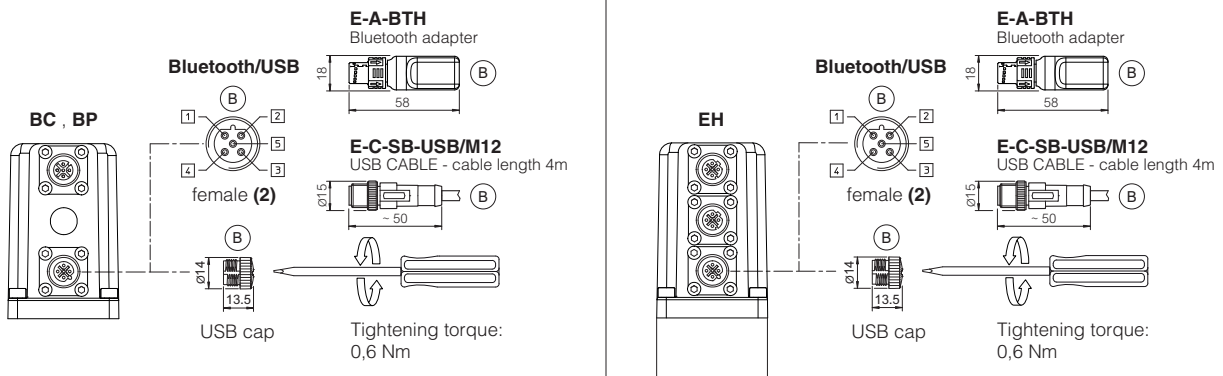

(1) Use of metallic connectors is strongly recommended in order to fulfill EMC requirements

(2) Pin layout always referred to driver's view

**24 CONNECTORS CHARACTERISTICS** - to be ordered separately

**24.1 Main connectors - 7 pin - for REB-NP and RES**

CONNECTOR TYPE	POWER SUPPLY AND SIGNALS	POWER SUPPLY AND SIGNALS
<b>CODE</b>	<b>(A1) ZM-7P</b>	<b>(A3) ZH-7P</b>
Type	7pin female straight circular	7pin female straight circular
Standard	According to MIL-C-5015	According to MIL-C-5015
Material	Metallic	Plastic reinforced with fiber glass
Cable gland	PG11	PG11
Recommended cable	LiYCY 7 x 0,75 mm <sup>2</sup> max 20 m (logic and power supply) or LiYCY 7 x 1 mm <sup>2</sup> max 40 m (logic and power supply)	LiYCY 7 x 0,75 mm <sup>2</sup> max 20 m (logic and power supply) or LiYCY 7 x 1 mm <sup>2</sup> max 40 m (logic and power supply)
Conductor size	up to 1 mm <sup>2</sup> - available for 7 wires	up to 1 mm <sup>2</sup> - available for 7 wires
Connection type	to solder	to solder
Protection (EN 60529)	IP 67	IP 67

**24.2 Main connectors - 12 pin - for REB-NP and RES**

CONNECTOR TYPE	POWER SUPPLY AND SIGNALS	POWER SUPPLY AND SIGNALS
<b>CODE</b>	<b>(A2) ZM-12P</b>	<b>(A4) ZH-12P</b>
Type	12pin female straight circular	12pin female straight circular
Standard	DIN 43651	DIN 43651
Material	Metallic	Plastic reinforced with fiber glass
Cable gland	PG13,5	PG16
Recommended cable	LiYCY 12 x 0,75 mm <sup>2</sup> max 20 m (logic and power supply)	LiYCY 10 x 0,14mm <sup>2</sup> max 40 m (logic) LiYY 3 x 1mm <sup>2</sup> max 40 m (power supply)
Conductor size	0,5 mm <sup>2</sup> to 1,5 mm <sup>2</sup> - available for 12 wires	0,14 mm <sup>2</sup> to 0,5 mm <sup>2</sup> - available for 9 wires 0,5 mm <sup>2</sup> to 1,5 mm <sup>2</sup> - available for 3 wires
Connection type	to crimp	to crimp
Protection (EN 60529)	IP 67	IP 67

**24.3 IO-Link connector - only for REB-IL**

CONNECTOR TYPE	IL IO-Link
<b>CODE</b>	<b>(A) ZM-5PF</b>
Type	5pin female straight circular
Standard	M12 coding A – IEC 61076-2-101
Material	Metallic
Cable gland	Pressure nut - cable diameter 6÷8 mm
Recommended cable	5 x 0,75 mm <sup>2</sup> max 20 m
Connection type	screw terminal
Protection (EN 60529)	IP 67



**24.4 Fieldbus communication connectors - only for RES**

CONNECTOR TYPE	BC CANopen (1)		BP PROFIBUS DP (1)		EH EtherCAT (2)	
<b>CODE</b>	<b>(C1) ZM-5PF</b>	<b>(C2) ZM-5PM</b>	<b>(C1) ZM-5PF/BP</b>	<b>(C2) ZM-5PM/BP</b>	<b>(C1) (C2) ZM-4PM/E</b>	
Type	5 pin female straight circular	5 pin male straight circular	5 pin female straight circular	5 pin male straight circular	4 pin male straight circular	
Standard	M12 coding A – IEC 61076-2-101		M12 coding B – IEC 61076-2-101		M12 coding D – IEC 61076-2-101	
Material	Metallic		Metallic		Metallic	
Cable gland	Pressure nut - cable diameter 6÷8 mm		Pressure nut - cable diameter 6÷8 mm		Pressure nut - cable diameter 4÷8 mm	
Cable	CANbus Standard (DR 303-1)		PROFIBUS DP Standard		Ethernet standard CAT-5	
Connection type	screw terminal		screw terminal		terminal block	
Protection (EN 60529)	IP67		IP 67		IP 67	

**(1)** E-TRM-\*\* terminators can be ordered separately - see tech table **GS500**

**(2)** Internally terminated

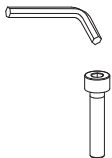
**25 FASTENING BOLTS AND SEALS**

	AGMZO-*-10	AGMZO-*-20	AGMZO-*-32
	<b>Fastening bolts:</b> 4 socket head screws M12x35 class 12.9 Tightening torque = 125 Nm	<b>Fastening bolts:</b> 4 socket head screws M16x50 class 12.9 Tightening torque = 300 Nm	<b>Fastening bolts:</b> 4 socket head screws M20x60 class 12.9 Tightening torque = 600 Nm
	<b>Seals:</b> 2 OR 123 Diameter of ports P, T: Ø 14 mm 1 OR 109/70 Diameter of port X: Ø 3,2 mm	<b>Seals:</b> 2 OR 4112 Diameter of ports P, T: Ø 24 mm 1 OR 109/70 Diameter of port X: Ø 3,2 mm	<b>Seals:</b> 2 OR 4131 Diameter of ports P, T: Ø 28 mm 1 OR 109/70 Diameter of port X: Ø 3,2 mm

### SIZE 10

ISO 6264: 2007  
 Mounting surface: 6264-06-09-1-97  
 (see table P005)

	Mass [kg]		
	R	REB, RES	RES-EH
AGMZO-*-10	5,7	6,2	6,3

AGMZO-REB-P-NP-10  
 AGMZO-REB-P-IL-10  
 AGMZO-RES-P-BC-10  
 AGMZO-RES-P-BP-10

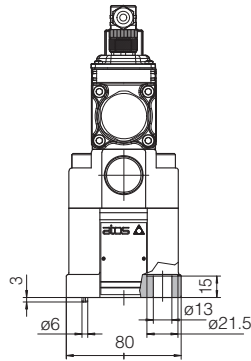
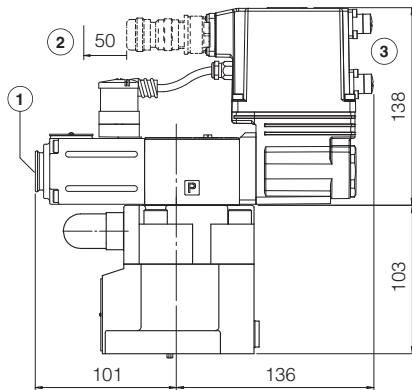

AGMZO-R-P-10

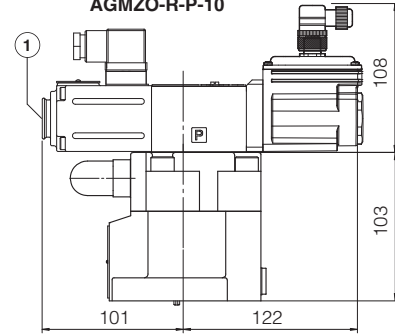

AGMZO-RES-P-EH-10

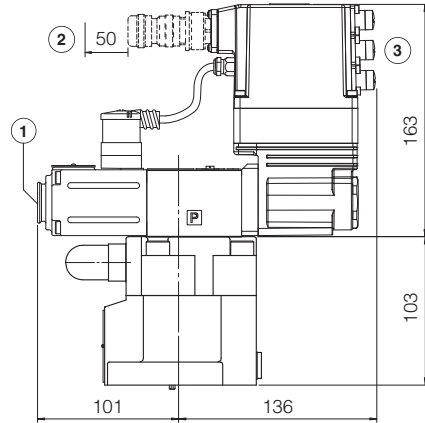

### SIZE 20

ISO 6264: 2007  
 Mounting surface: 6264-08-13-1-97  
 (see table P005)

	Mass [kg]		
	R	REB, RES	RES-EH
AGMZO-*-20	6,9	7,4	7,5

AGMZO-REB-P-NP-20  
 AGMZO-REB-P-IL-20  
 AGMZO-RES-P-BC-20  
 AGMZO-RES-P-BP-20

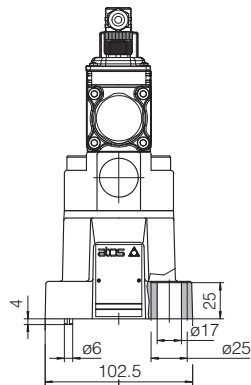
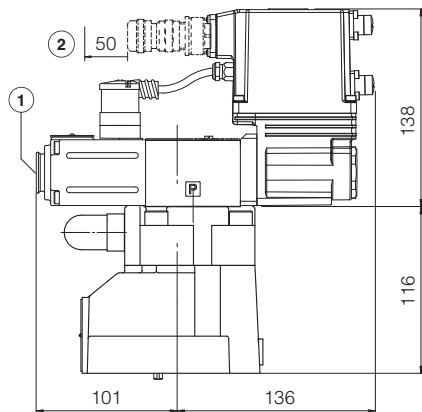

AGMZO-R-P-20

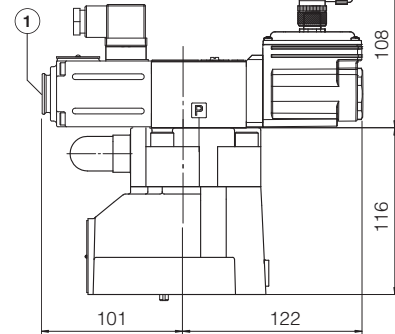

AGMZO-RES-P-EH-20

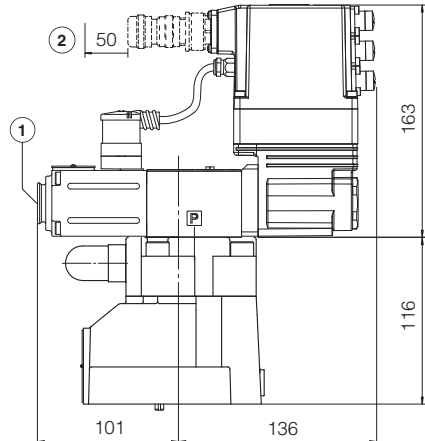

① = Air bleeding, see section 20

② = Space required for connection cable and for connector removal

③ = The dimensions of connectors and Bluetooth adapter must be considered, see section 23.7, 23.8 and 23.9

## SIZE 32

ISO 6264: 2007

Mounting surface: 6264-10-17-1-97

(see table P005)

(with M20 fixing holes instead of standard M18)

	Mass [kg]		
	R	REB, AES	RES-EH
AGMZO-*-32	8,3	8,8	8,9

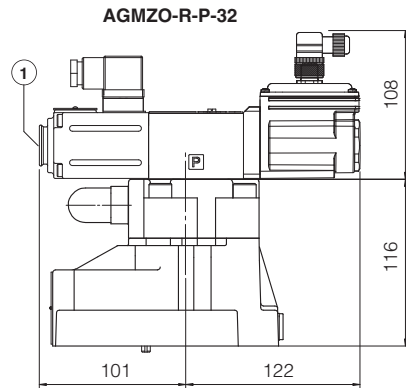
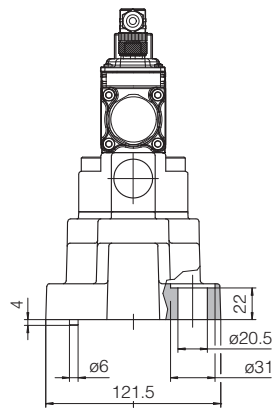

AGMZO-REB-P-NP-32  
AGMZO-REB-P-IL-32  
AGMZO-RES-P-BC-32  
AGMZO-RES-P-BP-32

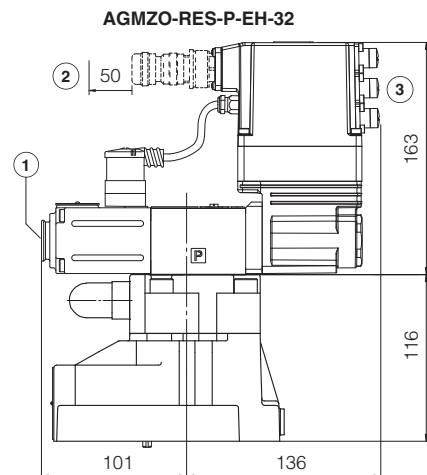
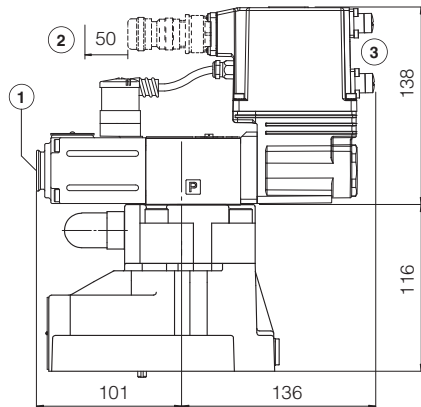

① = Air bleeding, see section 20 

② = Space required for connection cable and for connector removal

③ = The dimensions of connectors and Bluetooth adapter must be considered, see section 23.7, 23.8 and 23.9

### 27 RELATED DOCUMENTATION

<b>FS001</b>	Basics for digital electrohydraulics	<b>P005</b>	Mounting surfaces for electrohydraulic valves
<b>FS900</b>	Operating and maintenance information for proportional valves	<b>QB400</b>	Quickstart for REB valves commissioning
<b>GS203</b>	E-BM-RES digital driver	<b>QF400</b>	Quickstart for RES valves commissioning
<b>GS500</b>	Programming tools	<b>E-MAN-BM-RES</b>	E-BM-RES user manual (off-board)
<b>GS510</b>	Fieldbus	<b>E-MAN-RI-REB</b>	REB user manual
<b>GS520</b>	IO-Link interface	<b>E-MAN-RI-RES</b>	RES user manual
<b>K800</b>	Electric and electronic connectors		