

Digital proportional relief valves

piloted, without transducer, subplate or modular mounting

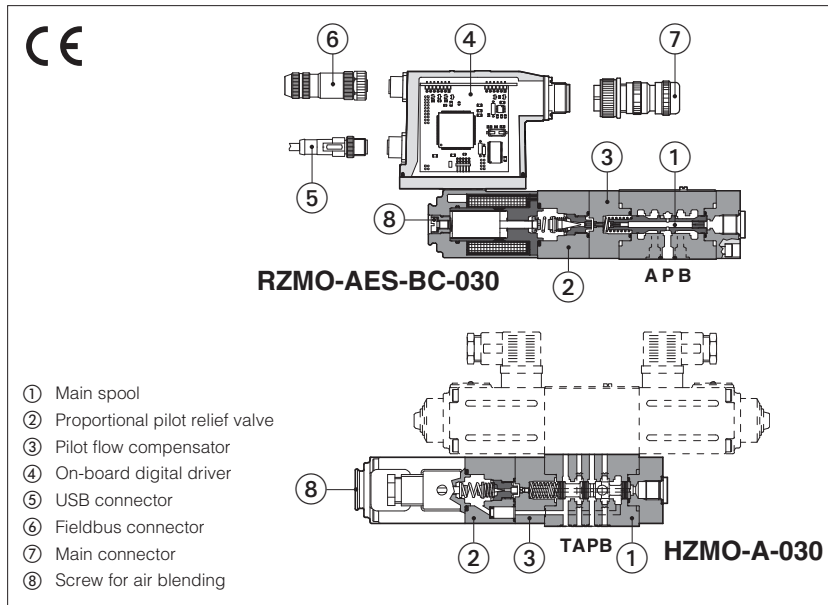

RZMO-A , RZMO-AEB, RZMO-AES HZMO-A

Spool type piloted digital proportional relief valves for pressure open loop controls, available in subplate or modular mounting.

A to be coupled with off-board driver.

AEB basic execution, with on-board digital driver, analog reference signals and USB port for software functional parameters setting.

AES full execution, with on-board digital driver which includes also fieldbus interface for functional parameters setting, reference signals and real-time diagnostics.

Size: **06** - ISO 4401

Max flow: **40 l/min**

Max pressure: **350 bar**

1 MODEL CODE

RZMO	-	AEB	-	NP	-	030	/	210	/	*	/	*	/	*	/	*
Proportional pressure relief valve, piloted RZMO = subplate HZMO = modular														Seals material, see section 10: - = NBR PE = FKM BT = HNBR		Series number
<p>A = for off-board driver, see section 3</p> <p>Only for RMZO: AEB = basic on-board digital driver (1) AES = full on-board digital driver (2)</p> <p>Fieldbus interfaces, USB port always present (3): NP = Not present BC = CANopen BP = PROFIBUS DP EH = EtherCAT</p> <p>Coil voltage, only for A - see section 14: - = standard coil for 24VDC Atos drivers 6 = optional coil for 12VDC Atos drivers 18 = optional coil for low current drivers</p> <p>Electronic options, only for AEB and AES (4): I = current reference input 4÷20 mA (omit for std voltage 0÷10 VDC) Q = enable signal Z = double power supply, enable, fault and monitor signals -12 pin connector</p> <p>Max regulated pressure: 50 = 50 bar 210 = 210 bar 350 = 350 bar 100 = 100 bar 315 = 315 bar</p>																

Configuration:

030 = regulation on port P, discharge in T (pilot operated version)

(1) Only for **NP**

(2) Only for **BC, BP, EH**

(3) Omit for **A** execution

(4) Possible combined options: IQ, IZ

2 HYDRAULIC SYMBOLS

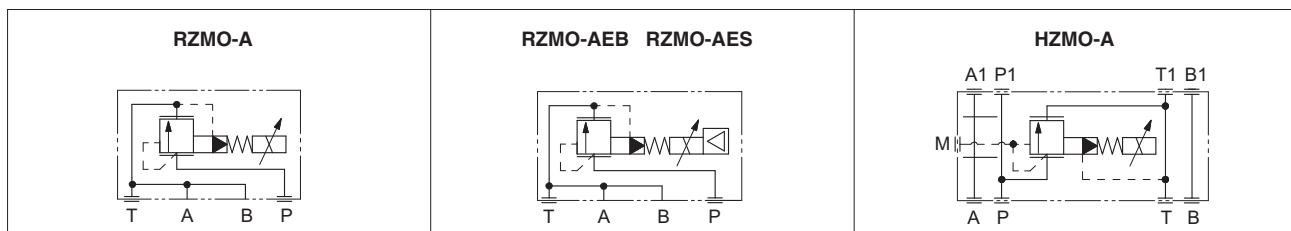

3 OFF-BOARD ELECTRONIC DRIVERS - only for A

Drivers model	E-MI-AC-01F		E-MI-AS-IR		E-BM-AS-PS		E-BM-AES
Type	Analog		Digital				
Voltage supply (VDC)	12	24	12	24	12	24	24
Valve coil option	/6	std	/6	std	/6	std	std
Format	plug-in to solenoid				DIN-rail panel		
Tech table	G010		G020		G030		GS050

4 GENERAL NOTES

Atos digital proportionals valves are CE marked according to the applicable directives (e.g. Immunity and Emission EMC Directive). Installation, wirings and start-up procedures must be performed according to the general prescriptions shown in tech table **FS900** and in the user manuals included in the E-SW-* programming software.

5 VALVE SETTINGS AND PROGRAMMING TOOLS

Valve's functional parameters and configurations, can be easily set and optimized using Atos E-SW programming software connected via USB port to the digital driver.

For fieldbus versions, the software permits valve's parameterization through USB port also if the driver is connected to the central machine unit via fieldbus.

The software is available in different versions according to the driver's options (see table **GS500**):

E-SW-BASIC support: NP (USB) PS (Serial) IR (Infrared)

E-SW-FIELDBUS support: BC (CANopen) BP (PROFIBUS DP) EH (EtherCAT)

EW (POWERLINK) EI (EtherNet/IP) EP (PROFINET)

E-SW-*PQ support: valves with SP, SF, SL alternated control (e.g. E-SW-BASIC/PQ)



WARNING: drivers USB port is not isolated! For E-C-SB-USB/M12 cable, the use of isolator adapter is highly recommended for PC protection



WARNING: see tech table **GS500** for the list of countries where the Bluetooth adapter has been approved

USB or Bluetooth connection

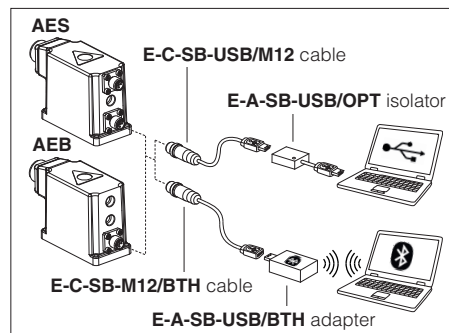

6 FIELDBUS - only for AES, see tech. table **GS510**

Fieldbus allows valve direct communication with machine control unit for digital reference, valve diagnostics and settings. These execution allow to operate the valves through fieldbus or analog signals available on the main connector.

7 GENERAL CHARACTERISTICS

Assembly position	Any position
Subplate surface finishing to ISO 4401	Acceptable roughness index: Ra ≤ 0,8, recommended Ra 0,4 – Flatness ratio 0,01/100
MTTFd valves according to EN ISO 13849	75 years, see technical table P007
Ambient temperature range	A: Standard = -20°C ÷ +70°C /PE option = -20°C ÷ +70°C /BT option = -40°C ÷ +60°C AEB, AES: Standard = -20°C ÷ +60°C /PE option = -20°C ÷ +60°C /BT option = -40°C ÷ +60°C
Storage temperature range	A: Standard = -20°C ÷ +80°C /PE option = -20°C ÷ +80°C /BT option = -40°C ÷ +70°C AEB, AES: Standard = -20°C ÷ +70°C /PE option = -20°C ÷ +70°C /BT option = -40°C ÷ +70°C
Surface protection	Zinc coating with black passivation, galvanic treatment (driver housing for AEB and AES)
Corrosion resistance	Salt spray test (EN ISO 9227) > 200 h
Compliance	CE according to EMC directive 2014/30/EU (Immunity: EN 61000-6-2; Emission: EN 61000-6-3) RoHS Directive 2011/65/EU as last update by 2015/863/EU REACH Regulation (EC) n°1907/2006

8 HYDRAULIC CHARACTERISTICS - based on mineral oil ISO VG 46 at 50 °C

Valve model	RZMO-*-030, HZMO-A-30	
Max regulated pressure [bar]	50; 100; 210; 315; 350	
Max pressure at port P [bar]	350	
Max pressure at port T [bar]	210	
Min regulated pressure [bar]	see min. pressure / flow diagram at section 11	
Min ÷ Max flow [l/min]	2,5 ÷ 40	
Response time 0-100% step signal (depending on installation) (1) [ms]	≤ 60	
Hysteresis	≤ 2 [% of max pressure]	
Linearity	≤ 3 [% of max pressure]	
Repeatability	≤ 2 [% of max pressure]	

Note: above performance data refer to valves coupled with Atos electronic drivers, see section **3**

(1) Average response time value; the pressure variation in consequence of a modification of the reference input signal to the valve is affected by the stiffness of the hydraulic circuit: greater is the stiffness of the circuit, faster is the dynamic response

9 ELECTRICAL CHARACTERISTICS

Power supplies	Nominal : +24 VDC Rectified and filtered : $V_{RMS} = 20 \div 32 V_{MAX}$ (ripple max 10 % VPP)			
Max power consumption	A = 30 W AEB, AES = 50 W			
Coil voltage code	standard	option /6		option /18
Max. solenoid current	2,6 A	3,25 A		1,5 A
Coil resistance R at 20°C	3 \div 3,3 Ω	2 \div 2,2 Ω		13 \div 13,4 Ω
Analog input signals	Voltage: range ± 10 VDC (24 VMAX tollerant) Current: range ± 20 mA		Input impedance: $R_i > 50$ k Ω Input impedance: $R_i = 500$ Ω	
Monitor output	Output range: voltage ± 5 VDC @ max 5 mA			
Enable input	Range: 0 \div 9 Vdc (OFF state), 15 \div 24 Vdc (ON state), 9 \div 15 Vdc (not accepted); Input impedance: $R_i > 87$ k Ω			
Fault output	Output range : 0 \div 24 VDC (ON state \equiv VL+ [logic power supply] ; OFF state \equiv 0 V) @ max 50 mA; external negative voltage not allowed (e.g. due to inductive loads)			
Alarms	Solenoid not connected/short circuit, cable break with current reference signal, over/under temperature, current control monitoring, power supplies level, pressure transducer failure (/W option)			
Insulation class	H (180°) Due to the occuring surface temperatures of the solenoid coils, the European standards ISO 13732-1 and EN982 must be taken into account			
Protection degree to DIN EN60529	A = IP65; AEB, AES = IP66 / IP67 with mating connectors			
Duty factor	Continuous rating (ED=100%)			
Tropicalization	Tropical coating on electronics PCB			
Additional characteristics	Short circuit protection of solenoid's current supply; current control by P.I.D. with rapid solenoid switching; protection against reverse polarity of power supply			
Communication interface	USB Atos ASCII coding	CANopen EN50325-4 + DS408	PROFIBUS DP EN50170-2/IEC61158	EtherCAT EC 61158
Communication physical layer	not insulated USB 2.0 + USB OTG	optical insulated CAN ISO11898	optical insulated RS485	Fast Ethernet, insulated 100 Base TX
Recommended wiring cable	LiYCY shielded cables, see section 18			

Note: a maximum time of 500 ms (depending on communication type) have be considered between the driver energizing with the 24 Vdc power supply and when the valve is ready to operate. During this time the current to the valve coils is switched to zero.

10 SEALS AND HYDRAULIC FLUIDS - for other fluids not included in below table, consult our technical office

Seals, recommended fluid temperature	NBR seals (standard) = -20°C \div +60°C (+80°C for A), with HFC hydraulic fluids = -20°C \div +50°C FKM seals (/PE option) = -20°C \div +80°C HNBR seals (/BT option) = -40°C \div +60°C, with HFC hydraulic fluids = -40°C \div +50°C			
Recommended viscosity	20 \div 100 mm ² /s - max allowed range 15 \div 380 mm ² /s			
Max fluid contamination level	normal operation	ISO4406 class 18/16/13 NAS1638 class 7		see also filter section at
	longer life	ISO4406 class 16/14/11 NAS1638 class 5		www.atos.com or KTF catalog
Hydraulic fluid	Suitable seals type	Classification	Ref. Standard	
Mineral oils	NBR, FKM, HNBR	HL, HLP, HLPD, HVLP, HVLPD	DIN 51524	
Flame resistant without water	FKM	HFDU, HFDR	ISO 12922	
Flame resistant with water	NBR, HNBR	HFC		

11 DIAGRAMS (based on mineral oil ISO VG 46 at 50 °C)

1 Regulation diagrams with flow rate Q = 10 l/min

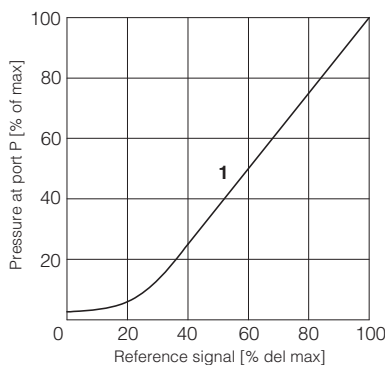

2 Pressure/flow diagrams with reference signal set at Q = 10 l/min

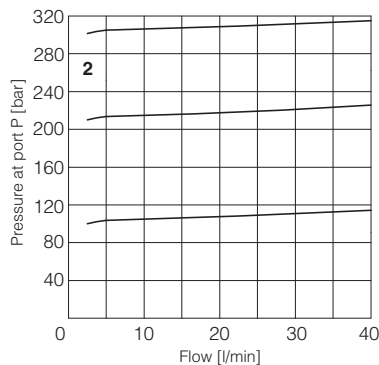

3-4 Min. pressure/flow diagrams with zero reference signal

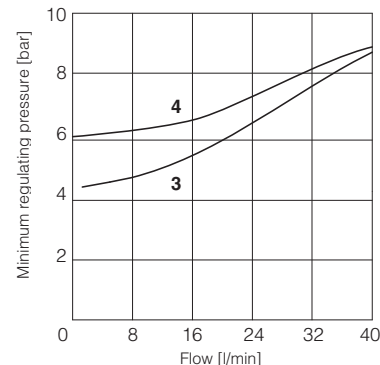

3 = All the models (except /350)
4 = All the models (only /350)

Note: the presence of counter pressure at port T can affect the pressure regulation and the minimum pressure

12 ELECTRONIC OPTIONS - only for AEB and AES

- I** = This option provides 4 ÷ 20 mA current reference and monitor signals, instead of the standard 0 ÷ 10 VDC. Input signal can be reconfigured via software selecting between voltage and current, within a maximum range of ±10 VDC or ±20 mA. It is normally used in case of long distance between the machine control unit and the valve or where the reference signal can be affected by electrical noise; the valve functioning is disabled in case of reference signal cable breakage.
- Q** = This option permits to inhibit the valve function without removing the power supply to the driver. Upon disable command the current to the solenoid is zeroed and the valve's spool moves to rest position. The option /Q is suggested for all cases where the valve has to be frequently inhibited during the machine cycle – see 16.5 for signal specifications.
- Z** = This option provides, on the 12 pin main connector, the following additional features:
Fault output signal - see 16.6
Enable input signal - see above option /Q
Power supply for driver's logics and communication - see 16.2

13 POSSIBLE COMBINED OPTIONS

Electronics options: /IQ, /IZ

14 COIL VOLTAGE OPTIONS - only for A

- 6** = Optional coil to be used with Atos drivers with power supply 12 VDC.
- 18** = Optional coil to be used with electronic drivers not supplied by Atos.

15 AIR BLEEDING

At the first valve commissioning the air eventually trapped inside the solenoid must be bled-off through the screw ① located at the rear side of the solenoid housing. The presence of air may cause pressure instability and vibrations.

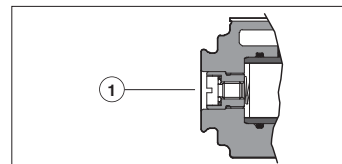

16 POWER SUPPLY AND SIGNALS SPECIFICATIONS - only for AEB and AES

Generic electrical output signals of the valve (e.g. fault or monitor signals) must not be directly used to activate safety functions, like to switch-ON/OFF the machine's safety components, as prescribed by the European standards (Safety requirements of fluid technology systems and components-hydraulics, ISO 4413).

16.1 Power supply (V+ and V0)

The power supply must be appropriately stabilized or rectified and filtered: apply at least a 10000 µF/40 V capacitance to single phase rectifiers or a 4700 µF/40 V capacitance to three phase rectifiers. In case of separate power supply see 16.2.



A safety fuse is required in series to each power supply: 2,5 A time lag fuse.

16.2 Power supply for driver's logic and communication (VL+ and VL0) - only for /Z option

The power supply for driver's logic and communication must be appropriately stabilized or rectified and filtered: apply at least a 10000 µF/40 V capacitance to single phase rectifiers or a 4700 µF/40 V capacitance to three phase rectifiers.

The separate power supply for driver's logic on pin 9 and 10, allow to remove solenoid power supply from pin 1 and 2 maintaining active the diagnostics, USB and fieldbus communications.



A safety fuse is required in series to each driver's logic and communication power supply: 500 mA fast fuse.

16.3 Reference input signal (INPUT+)

The driver controls in closed loop the current to the valve proportionally to the external reference input signal.

Reference input signal is factory preset according to selected valve code, defaults are 0 ÷ 10 V_{DC} for standard and 4 ÷ 20 mA for /I option.

Input signal can be reconfigured via software selecting between voltage and current, within a maximum range of ±10 V_{DC} or ± 20 mA.

Drivers with fieldbus interface (BC, BP, EH) can be software set to receive reference signal directly from the machine control unit (fieldbus reference). Analog reference input signal can be used as on-off commands with input range 0 ÷ 24V_{DC}.

16.4 Monitor output signal (MONITOR)

The driver generates an analog output signal (MONITOR) proportional to the actual coil current of the valve; the monitor output signal can be software set to show other signals available in the driver (e.g. analog reference, fieldbus reference).

Monitor output signal is factory preset according to selected valve code, default settings is ±5 V_{DC} (1V = 1A).

Output signal can be reconfigured via software, within a maximum range of 0 ÷ 5 V_{DC}.

16.5 Enable input signal (ENABLE) - not for standard

To enable the driver, supply a 24 V_{DC} on pin 3 (pin C): Enable input signal allows to enable/disable the current supply to the solenoid, without removing the electrical power supply to the driver; it is used to active the communication and the other driver functions when the valve must be disabled for safety reasons. This condition **does not comply** with norms IEC 61508 and ISO 13849.

Enable input signal can be used as generic digital input by software selection.

16.6 Fault output signal (FAULT) - only for /Z option

Fault output signal indicates fault conditions of the driver (solenoid short circuits/not connected, reference signal broken for 4 ÷ 20 mA input, etc.).

Fault presence corresponds to 0 V_{DC}, normal working corresponds to 24 V_{DC}.

Fault status is not affected by the Enable input signal.

17 ELECTRONIC CONNECTIONS

17.1 Main connector signals - 7 pin (A1) Standard and /Q option - for AEB and AES

PIN	Standard	/Q	TECHNICAL SPECIFICATIONS	NOTES
A	V+		Power supply 24 Vdc	Input - power supply
B	V0		Power supply 0 Vdc	Gnd - power supply
C	AGND		Analog ground	Gnd - analog signal
		ENABLE	Enable (24 Vdc) or disable (0 Vdc) the driver, referred to V0	Input - on/off signal
D	INPUT+		Reference input signal: ± 10 Vdc / ± 20 mA maximum range Defaults are 0 ÷ 10 Vdc for standard and 4 ÷ 20 mA for /I option	Input - analog signal Software selectable
E	INPUT-		Negative reference input signal for INPUT+	Input - analog signal
F	MONITOR referred to: AGND V0		Monitor output signal: ± 5 Vdc maximum range Default is 0 ÷ 5 Vdc (1V = 1A)	Output - analog signal Software selectable
G	EARTH		Internally connected to driver housing	

17.2 Main connector signals - 12 pin (A2) /Z option - for AEB and AES

PIN	/Z	TECHNICAL SPECIFICATIONS	NOTES
1	V+	Power supply 24 Vdc	Input - power supply
2	V0	Power supply 0 Vdc	Gnd - power supply
3	ENABLE	Enable (24 Vdc) or disable (0 Vdc) the driver, referred to VL0	Input - on/off signal
4	INPUT+	Reference input signal: ± 10 Vdc / ± 20 mA maximum range Defaults are 0 ÷ 10 Vdc for standard and 4 ÷ 20 mA for /I option	Input - analog signal Software selectable
5	INPUT-	Negative reference input signal for INPUT+	Input - analog signal
6	MONITOR	Monitor output signal: ± 5 Vdc maximum range, referred to VL0 Default is 0 ÷ 5 Vdc (1V = 1A)	Output - analog signal Software selectable
7	NC	Do not connect	
8	NC	Do not connect	
9	VL+	Power supply 24 Vdc for driver's logic and communication	Input - power supply
10	VL0	Power supply 0 Vdc for driver's logic and communication	Gnd - power supply
11	FAULT	Fault (0 Vdc) or normal working (24 Vdc), referred to VL0	Output - on/off signal
PE	EARTH	Internally connected to driver housing	

Note: do not disconnect VL0 before VL+ when the driver is connected to PC USB port

17.3 Communication connectors - for AEB (B) and AES (B) - (C)

(B) USB connector - M12 - 5 pin always present		
PIN	SIGNAL	TECHNICAL SPECIFICATION (1)
1	+5V_USB	Power supply
2	ID	Identification
3	GND_USB	Signal zero data line
4	D-	Data line -
5	D+	Data line +

(C1) BC fieldbus execution, connector - M12 - 5 pin (2)		
PIN	SIGNAL	TECHNICAL SPECIFICATION (1)
1	CAN_SHLD	Shield
2	NC	do not connect
3	CAN_GND	Signal zero data line
4	CAN_H	Bus line (high)
5	CAN_L	Bus line (low)

(C2) BP fieldbus execution, connector - M12 - 5 pin (2)		
PIN	SIGNAL	TECHNICAL SPECIFICATION (1)
1	+5V	Termination supply signal
2	LINE-A	Bus line (high)
3	DGND	Data line and termination signal zero
4	LINE-B	Bus line (low)
5	SHIELD	

(C3) (C4) EH fieldbus execution, connector - M12 - 4 pin (2)		
PIN	SIGNAL	TECHNICAL SPECIFICATION (1)
1	TX+	Transmitter
2	RX+	Receiver
3	TX-	Transmitter
4	RX-	Receiver
Housing	SHIELD	

(1) Shield connection on connector's housing is recommended

(2) Only for AES execution

17.4 Solenoid connection - only for A

PIN	SIGNAL	TECHNICAL SPECIFICATION	Connector code 666
1	COIL	Power supply	
2	COIL	Power supply	
3	GND	Ground	

17.5 AEB connections layout

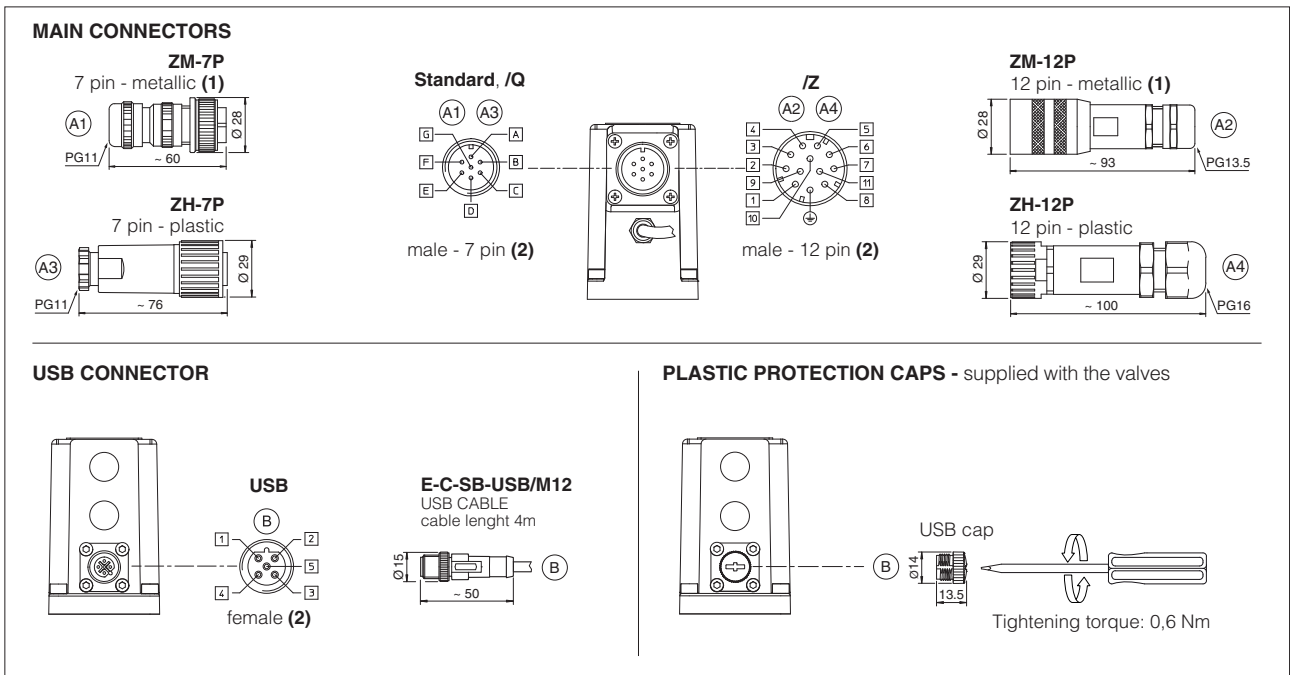

(1) Use of metallic connectors is strongly recommended in order to fulfill EMC requirements (2) Pin layout always referred to driver's view

17.6 AES connections layout

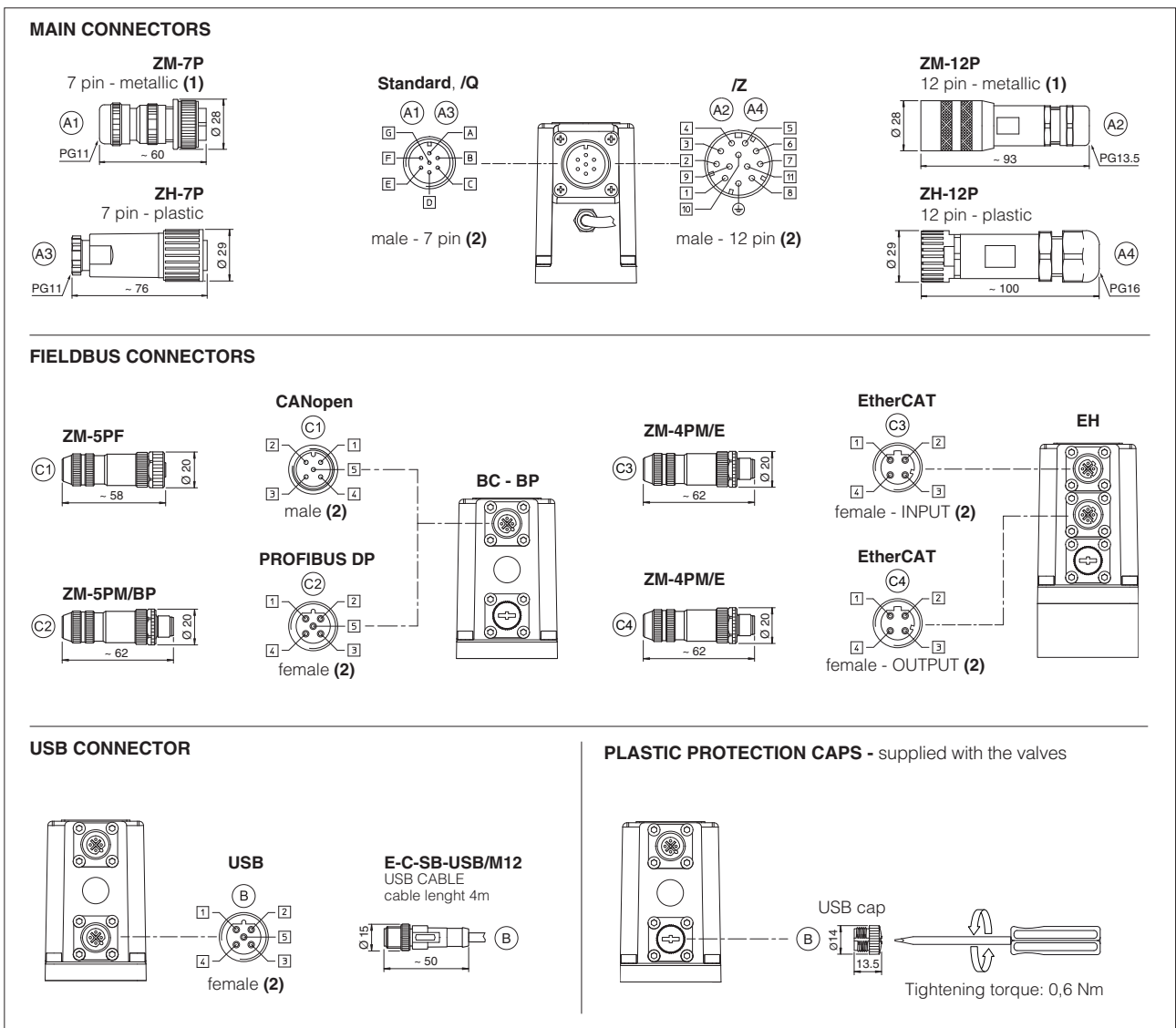

(1) Use of metallic connectors is strongly recommended in order to fulfill EMC requirements (2) Pin layout always referred to driver's view

18 CONNECTORS CHARACTERISTICS - to be ordered separately

18.1 Main connectors - 7 pin - for AEB and AES

CONNECTOR TYPE	POWER SUPPLY	POWER SUPPLY
CODE	(A1) ZM-7P	(A3) ZH-7P
Type	7pin female straight circular	7pin female straight circular
Standard	According to MIL-C-5015	According to MIL-C-5015
Material	Metallic	Plastic reinforced with fiber glass
Cable gland	PG11	PG11
Recommended cable	LiYCY 7 x 0,75 mm ² max 20 m (logic and power supply) or LiYCY 7 x 1 mm ² max 40 m (logic and power supply)	LiYCY 7 x 0,75 mm ² max 20 m (logic and power supply) or LiYCY 7 x 1 mm ² max 40 m (logic and power supply)
Conductor size	up to 1 mm ² - available for 7 wires	up to 1 mm ² - available for 7 wires
Connection type	to solder	to solder
Protection (EN 60529)	IP 67	IP 67

18.2 Main connectors - 12 pin - for AEB and AES

CONNECTOR TYPE	POWER SUPPLY	POWER SUPPLY
CODE	(A2) ZM-12P	(A4) ZH-12P
Type	12pin female straight circular	12pin female straight circular
Standard	DIN 43651	DIN 43651
Material	Metallic	Plastic reinforced with fiber glass
Cable gland	PG13,5	PG16
Recommended cable	LiYCY 12 x 0,75 mm ² max 20 m (logic and power supply)	LiYCY 10 x 0,14mm ² max 40 m (logic) LiYY 3 x 1mm ² max 40 m (power supply)
Conductor size	0,5 mm ² to 1,5 mm ² - available for 12 wires	0,14 mm ² to 0,5 mm ² - available for 9 wires 0,5 mm ² to 1,5 mm ² - available for 3 wires
Connection type	to crimp	to crimp
Protection (EN 60529)	IP 67	IP 67

18.3 Fieldbus communication connectors - only for AES

CONNECTOR TYPE	BC CANopen (1)		BP PROFIBUS DP (1)		EH EtherCAT (2)	
CODE	(C1) ZM-5PF	(C2) ZM-5PM	(C1) ZM-5PF/BP	(C2) ZM-5PM/BP	(C1) (C2) ZM-4PM/E	
Type	5 pin female straight circular	5 pin male straight circular	5 pin female straight circular	5 pin male straight circular	4 pin male straight circular	
Standard	M12 coding A – IEC 61076-2-101		M12 coding B – IEC 61076-2-101		M12 coding D – IEC 61076-2-101	
Material	Metallic		Metallic		Metallic	
Cable gland	Pressure nut - cable diameter 6÷8 mm		Pressure nut - cable diameter 6÷8 mm		Pressure nut - cable diameter 4÷8 mm	
Cable	CANbus Standard (DR 303-1)		PROFIBUS DP Standard		Ethernet standard CAT-5	
Connection type	screw terminal		screw terminal		terminal block	
Protection (EN 60529)	IP67		IP 67		IP 67	



(1) E-TRM-** terminators can be ordered separately - see tech table **GS500**

(2) Internally terminated

19 RELATED DOCUMENTATION

FS001	Basics for digital electrohydraulics	GS500	Programming tools
FS900	Operating and maintenance information for proportional valves	GS510	Fieldbus
G010	E-MI-AC analog driver	K800	Electric and electronic connectors
G020	E-MI-AS-IR digital driver	P005	Mounting surfaces for electrohydraulic valves
G030	E-BM-AS digital driver	QB200	Quickstart for AEB valves commissioning
GS050	E-BM-AES digital driver	QF200	Quickstart for AES valves commissioning

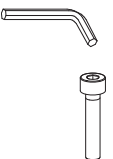
20 FASTENING BOLTS AND SEALS

	RZMO	HZMO
	Fastening bolts: 4 socket head screws M5x50 class 12.9 Tightening torque = 8 Nm	Fastening bolts: Not available
	Seals: 4 OR 108 Diameter of ports P, T: Ø 7,5 mm Ports A, B connected to port T	Seals: 4 OR 108 Diameter of ports P, T, A, B: Ø 6,5 mm

RZMO

ISO 4401: 2005
 Mounting surface: 4401-03-02-0-05
 (see table P005)

Mass [kg]		
A	AEB, AES	AES-EH
2,8	3,3	3,4

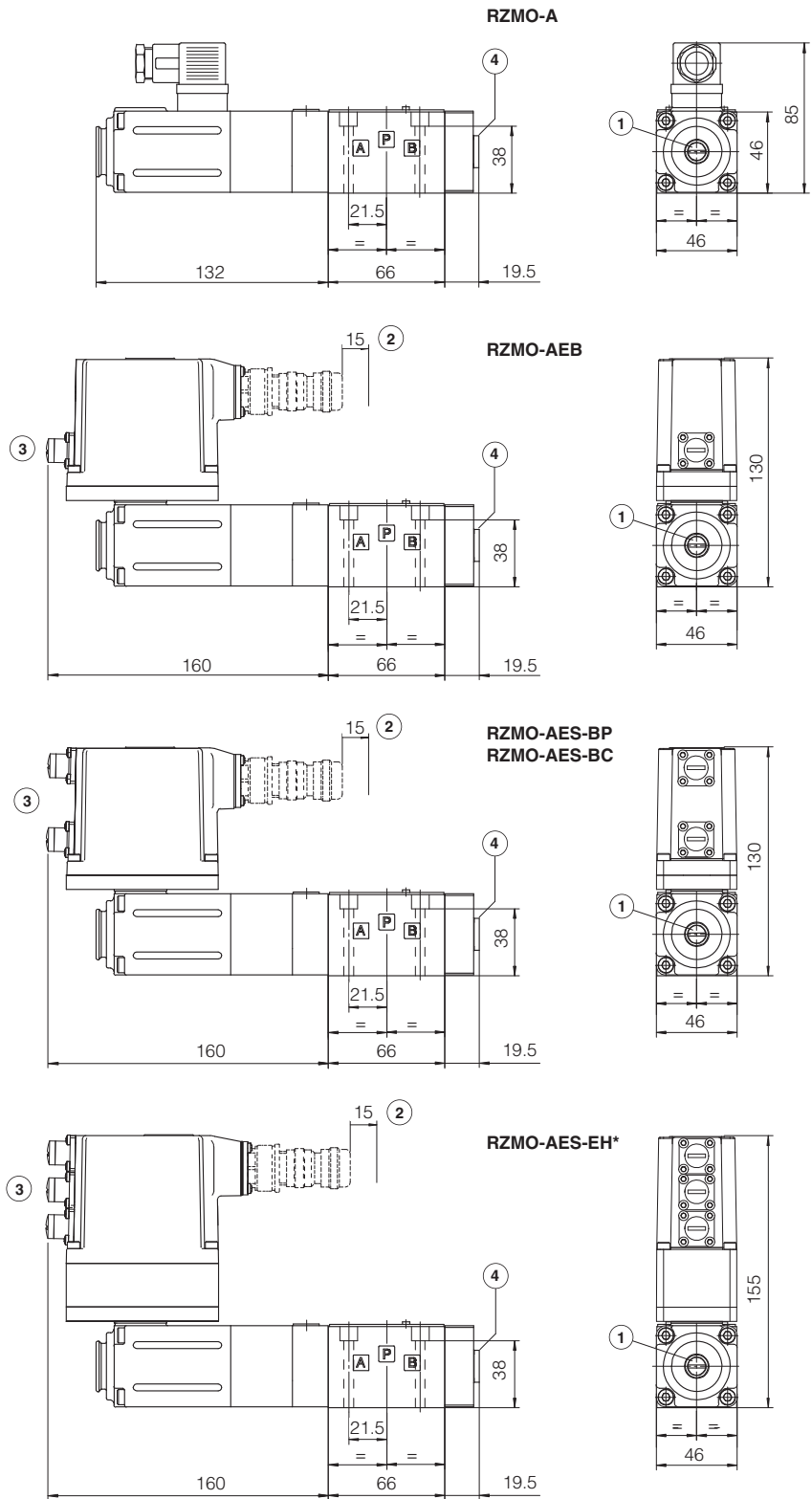

HZMO

ISO 4401: 2005
 Mounting surface: 4401-03-02-0-05
 (see table P005)

Mass [kg]
A
2,8

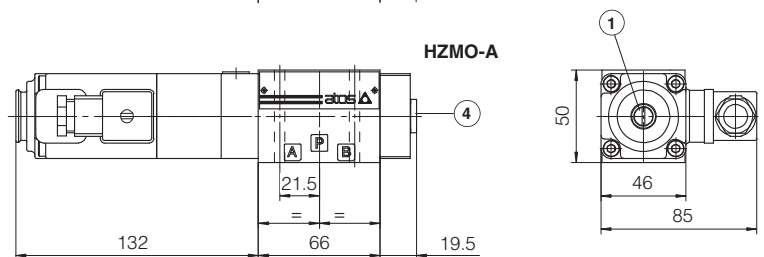

① = Air bleeding, see section 15 

② = Space to remove the connectors

③ = The dimensions of all connectors must be considered, see section 17.5 and 17.6

④ = Pressure gauge port = G1/4"