

Digital proportional directional valves high performance

direct, with on-board driver, LVDT transducer and positive spool overlap

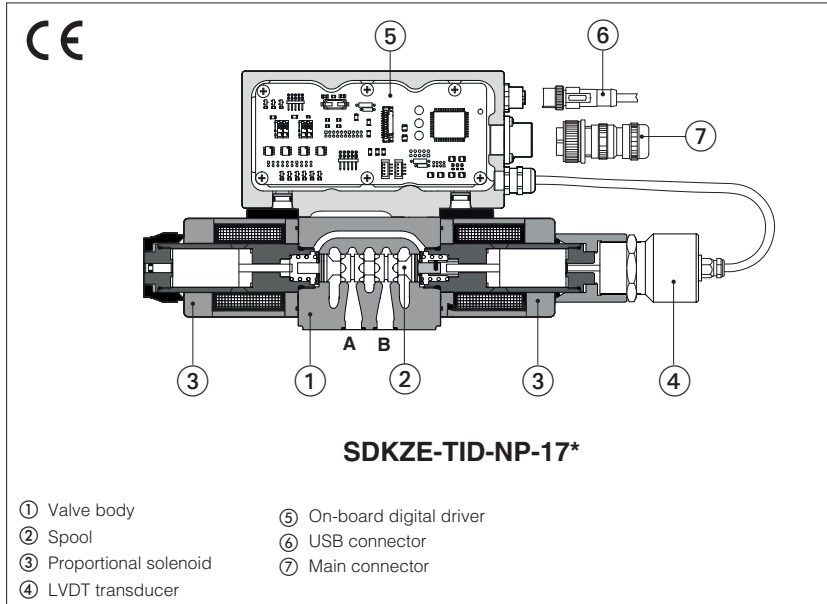

SDHZE-TID, SDKZE-TID

Digital high performances proportional directional valves, direct, with LVDT position transducer and positive spool overlap for directional controls and not compensated flow regulations.

TID on board digital driver performs the valve's hydraulic regulation according to the reference signal sent to the 7 pin main connector.

The software setting of functional parameters can be performed via USB port.

The LVDT transducer grants high regulation accuracy and response sensitivity.

With de-energized proportional solenoids, the mechanical central position of the spool is performed by centering springs.

SDHZE:

Size: **06** - ISO 4401
 4/3 and 4/2 way
 Max flow: **80 l/min**
 Max pressure: **350 bar**

SDKZE:

Size: **10** - ISO 4401
 4/3 and 4/2 way
 Max flow: **180 l/min**
 Max pressure: **315 bar**

1 MODEL CODE

SDHZE	-	TID	-	NP	-	0	71	-	S	5	/	*	-	*	/	*	
SDHZE = size 06 SDKZE = size 10																Seals material, see section 7 : Series number - = NBR PE = FKM	
TID = on-board digital driver and LVDT transducer																	
Fieldbus interfaces , USB port always present: NP = Not present																	
Valve size ISO 4401: 0 = 06 1 = 10																	
Hydraulic options , see section 9 : B = on-board digital driver connections and LVDT position transducer at side of port A																	
Electronic options , see section 10 : I = current reference input and monitor 4÷20mA																	
Spool size: 3 (L,S,D) 5 (L,S,D) SDHZE = 18 28 SDKZE = 55 85 Nominal flow (l/min) at Δp 10 bar P-T																	

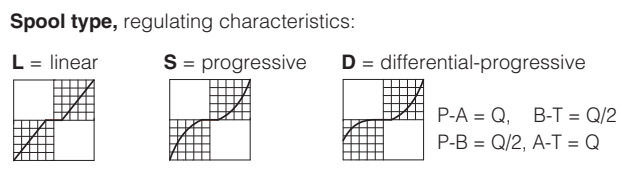
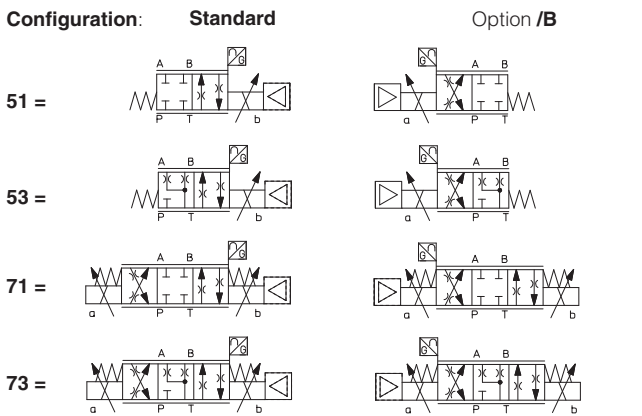

2 GENERAL NOTES

Atos digital proportionals valves are CE marked according to the applicable directives (e.g. Immunity and Emission EMC Directive). Installation, wirings and start-up procedures must be performed according to the general prescriptions shown in the user manuals included in the E-SW-* programming software.

3 VALVE SETTINGS AND PROGRAMMING TOOLS

Valve's functional parameters and configurations, can be easily set and optimized using Atos E-SW-BASIC programming software connected via USB port to the digital driver, see tech. table **GS500-SH**.

WARNING: drivers **USB port is not isolated!** For E-C-SB-USB/M12 cable, the use of isolator adapter is highly recommended for PC protection

WARNING: see tech table **GS500-SH** for the list of countries where the Bluetooth adapter has been approved

USB or Bluetooth connection

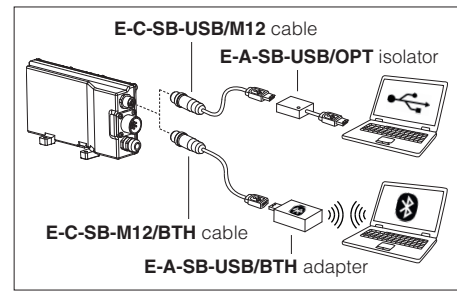

4 GENERAL CHARACTERISTICS

Assembly position	Any position
Subplate surface finishing to ISO 4401	Acceptable roughness index: $R_a \leq 0,8$, recommended $R_a 0,4$ – Flatness ratio 0,01/100
MTTFd valves according to EN ISO 13849	150 years, see technical table P007
Ambient temperature range	Standard = $-20^\circ\text{C} \div +60^\circ\text{C}$ /PE option = $-20^\circ\text{C} \div +60^\circ\text{C}$
Storage temperature range	Standard = $-20^\circ\text{C} \div +70^\circ\text{C}$ /PE option = $-20^\circ\text{C} \div +70^\circ\text{C}$
Surface protection	Zinc coating with black passivation (body), tin plating (driver housing)
Corrosion resistance	Salt spray test (EN ISO 9227) > 200 h
Conformity	CE according to EMC directive 2014/30/EU (Immunity: EN 61000-6-2; Emission: EN 61000-6-3) RoHS Directive 2011/65/EU as last update by 2015/863/EU REACH Regulation (EC) n°1907/2006

5 HYDRAULIC CHARACTERISTICS - based on mineral oil ISO VG 46 at 50 °C

Valve model	SDHZE						SDKZE									
	ports P, A, B = 350; T = 210						ports P, A, B = 315; T = 210									
Pressure limits [bar]																
Spool type (1)	L3, S3		D3		L5, S5		D5		L3, S3		D3		L5, S5		D5	
Nominal flow Δp P-T (2)	[l/min]	$\Delta p = 10$ bar	P-A	P-B	28	P-A	P-B	55	P-A	P-B	85	P-A	P-B	130	P-A	P-B
			$\Delta p = 30$ bar	18		18	9		28	28		14	100		100	50
Max permissible flow		50	50	25	80	80	40	130	130	65	180	180	125			
Leakage [cm ³ /min]	<30 (at p = 100 bar); <135 (at p = 350 bar)						<80 (at p = 100 bar); <600 (at p = 315 bar)									
Response time (3) [ms]	≤ 15						≤ 20									
Hysteresis	$\leq 0,2$ [% of max regulation]															
Repeatability	$\pm 0,1$ [% of max regulation]															
Thermal drift	zero point displacement < 1% at $\Delta T = 40^\circ\text{C}$															

(1) For spool type **D*** the flow value is referred to $\Delta p/2$ per control edge

(2) For different Δp , the max flow is in accordance to the diagrams in section 8.2

(3) 0-100% step signal

6 ELECTRICAL CHARACTERISTICS

Power supply	Nominal : +24 Vdc Rectified and filtered : $V_{RMS} = 20 \div 32 V_{MAX}$ (ripple max 10 % VPP)
Max power consumption	50 W
Max. solenoid current	SDHZE = 2,6 A SDKZE = 3 A
Coil resistance R at 20°C	SDHZE = 3,1 Ω SDKZE = 3,2 Ω
Analog input signals	Voltage: range ± 10 Vdc (24 V_{MAX} tollerant) Input impedance: $R_i > 50$ k Ω Current: range ± 20 mA Input impedance: $R_i = 500$ Ω
Monitor outputs	Output range: voltage ± 10 Vdc @ max 5 mA current ± 20 mA @ max 500 Ω load resistance
Alarms	Solenoid not connected/short circuit, cable break with current reference signal, over/under temperature, valve spool transducer malfunctions, alarms history storage function
Insulation class	H (180°) Due to the occurring surface temperatures of the solenoid coils, the European standards ISO 13732-1 and EN982 must be taken into account
Protection degree to DIN EN60529	IP66 / IP67 with mating connectors
Duty factor	Continuous rating (ED=100%)
Additional characteristics	Short circuit protection of solenoid's current supply; spool position control by P.I.D. with rapid solenoid switching; protection against reverse polarity of power supply
Communication interface	USB - Atos ASCII coding
Communication physical layer	not insulated - USB 2.0 + USB OTG
Recommended wiring cable	LiYCY shielded cables, see section 13

Note: a maximum time of 400 ms has to be considered between the driver energizing with the 24 Vdc power supply and when the valve is ready to operate. During this time the current to the valve coils is switched to zero.

7 SEALS AND HYDRAULIC FLUID - for other fluids not included in below table, consult Atos Technical Office

Seals, recommended fluid temperature	NBR seals (standard) = -20°C ÷ +60°C, with HFC hydraulic fluids = -20°C ÷ +50°C FKM seals (/PE option) = -20°C ÷ +80°C		
Recommended viscosity	20 ÷ 100 mm ² /s - max allowed range 15 ÷ 380 mm ² /s		
Max fluid contamination level	normal operation	ISO4406 class 18/16/13 NAS1638 class 7	see also filter section at www.atos.com or KTF catalog
	longer life	ISO4406 class 16/14/11 NAS1638 class 5	
Hydraulic fluid	Suitable seals type	Classification	Ref. Standard
Mineral oils	NBR, FKM	HL, HLP, HLPD, HVLP, HVLPD	DIN 51524
Flame resistant without water	FKM	HFDU, HFDR	ISO 12922
Flame resistant with water	NBR	HFC	

8 DIAGRAMS (based on mineral oil ISO VG 46 at 50 °C)

8.1 Regulation diagrams - values measure at Δp 30 bar P-T

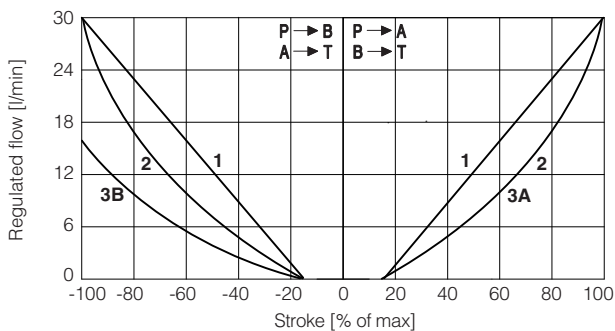

SDHZE

1 = L3 2 = S3 3A = D3 (P → A, A → T)
3B = D3 (P → B, B → T)

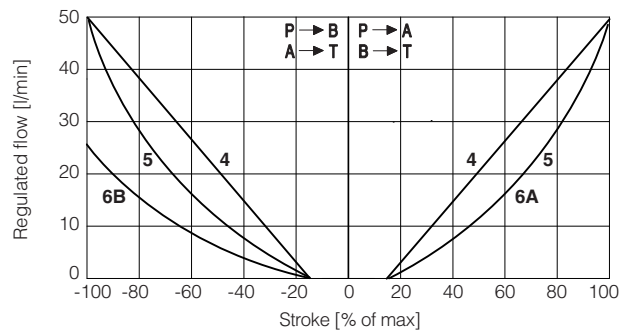

SDHZE

4 = L5 5 = S5 6A = D5 (P → A, A → T)
6B = D5 (P → B, B → T)

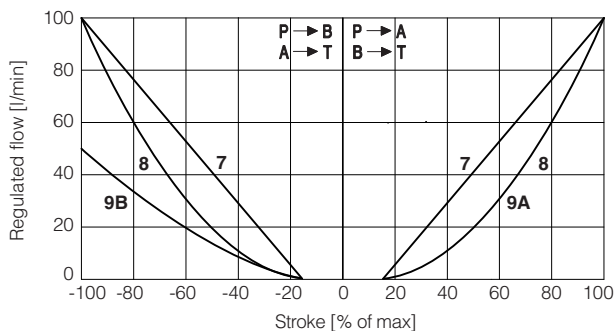

SDKZE

7 = L3 8 = S3 9A = D3 (P → A, A → T)
9B = D3 (P → B, B → T)

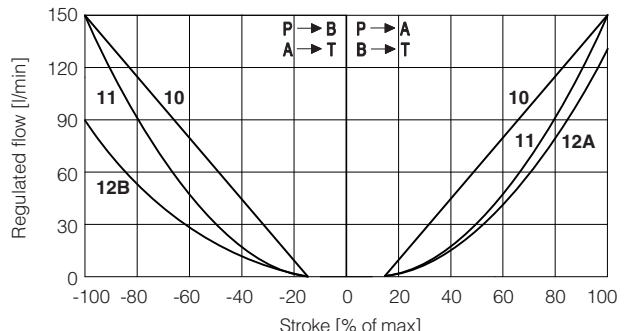

SDKZE

10 = L5 11 = S5 12A = D5 (P → A, A → T)
12B = D5 (P → B, B → T)

Note: Hydraulic configuration vs. reference signal for configuration 71 and 73 (standard and option /B)

Reference signal $\left. \begin{matrix} 0 \div +10 \text{ V} \\ 12 \div 20 \text{ mA} \end{matrix} \right\} P \rightarrow A / B \rightarrow T$

Reference signal $\left. \begin{matrix} 0 \div -10 \text{ V} \\ 12 \div 4 \text{ mA} \end{matrix} \right\} P \rightarrow B / A \rightarrow T$

8.2 Operating limits

SDHZE

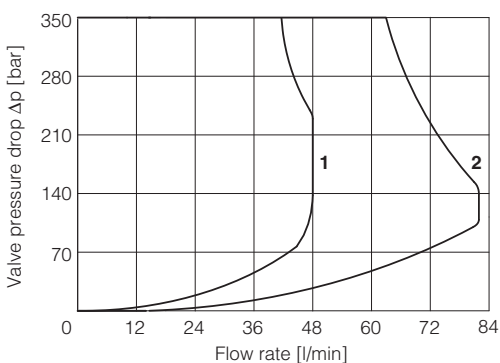

1 = spool L3, S3, D3 2 = spool L5, S5, D5

SDKZE

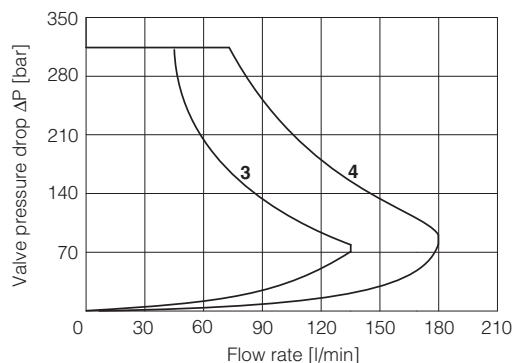

3 = spool S3, L3, D3 4 = spool S5, L5, D5

9 HYDRAULIC OPTIONS

- B** = Configurations 51, 53: solenoid, on-board digital driver connections and LVDT transducer at side of port A.
Configurations 71, 73: on-board digital driver connections and LVDT transducer at side of port A.
For hydraulic configuration vs reference signal, see 8.1

10 ELECTRONIC OPTIONS

- I** = This option provides 4 ÷ 20 mA current reference and monitor signals, instead of the standard ±10 VDC.
It is normally used in case of long distance between the machine control unit and the valve or where the reference signal can be affected by electrical noise; the valve functioning is disabled in case of reference signal cable breakage.

11 POWER SUPPLY AND SIGNALS SPECIFICATIONS

11.1 Power supply (V+ and V0)

The power supply must be appropriately stabilized or rectified and filtered: apply at least a 10000 µF/40 V capacitance to single phase rectifiers or a 4700 µF/40 V capacitance to three phase rectifiers.

 A safety fuse is required in series to the power supply: 2,5 A time lag fuse.

11.2 Flow reference input signal (Q_INPUT+)

The driver controls in closed loop the valve spool position proportionally to the external reference input signal.
Standard (voltage reference input): default is ±10 VDC and can be reconfigured via software, within a maximum range of ±10 Vdc.
Option /I (current reference input): default is 4 ÷ 20 mA and can be reconfigured via software, within a maximum range of ± 20 mA.

11.3 Flow monitor output signal (Q_MONITOR)

The driver generates an analog output signal proportional to the actual spool position of the valve; the monitor output signal can be software set to show other signals available in the driver.

Standard (voltage monitor output): default is ±10 VDC and can be reconfigured via software, within a maximum range of ±10 Vdc.
Option /I (current monitor output): default is 4 ÷ 20 mA and can be reconfigured via software, within a maximum range of ± 20 mA.

Note:

- monitor output signal must not be directly used to activate safety functions, like to switch-ON/OFF the machine's safety components, as prescribed by the European standards (Safety requirements of fluid technology systems and components-hydraulics, ISO 4413).

12 ELECTRONIC CONNECTIONS

12.1 Main connector signals - 7 pin (A1)

PIN	SIGNAL	TECHNICAL SPECIFICATIONS	NOTES
A	V+	Power supply 24 Vdc	Input - power supply
B	V0	Power supply 0 Vdc	Gnd - power supply
C	AGND	Analog ground	Gnd - analog signal
D	Q_INPUT+	Flow reference input signal: ±10 Vdc maximum range ±10 Vdc for standard, 4 ÷ 20 mA for /I option	Input - analog signal
E	INPUT-	Negative reference input signal for Q_INPUT+	Input - analog signal
F	Q_MONITOR	Flow monitor output signal: ±10 Vdc maximum range, referred to AGND ±10 Vdc for standard, 4 ÷ 20 mA for /I option	Output - analog signal
G	EARTH	Internally connected to driver housing	

12.2 Communication connectors (B)

(B) USB connector - M12 - 5 pin always present		
PIN	SIGNAL	TECHNICAL SPECIFICATION (1)
1	+5V_USB	Power supply
2	ID	Identification
3	GND_USB	Signal zero data line
4	D-	Data line -
5	D+	Data line +

12.3 Connections layout

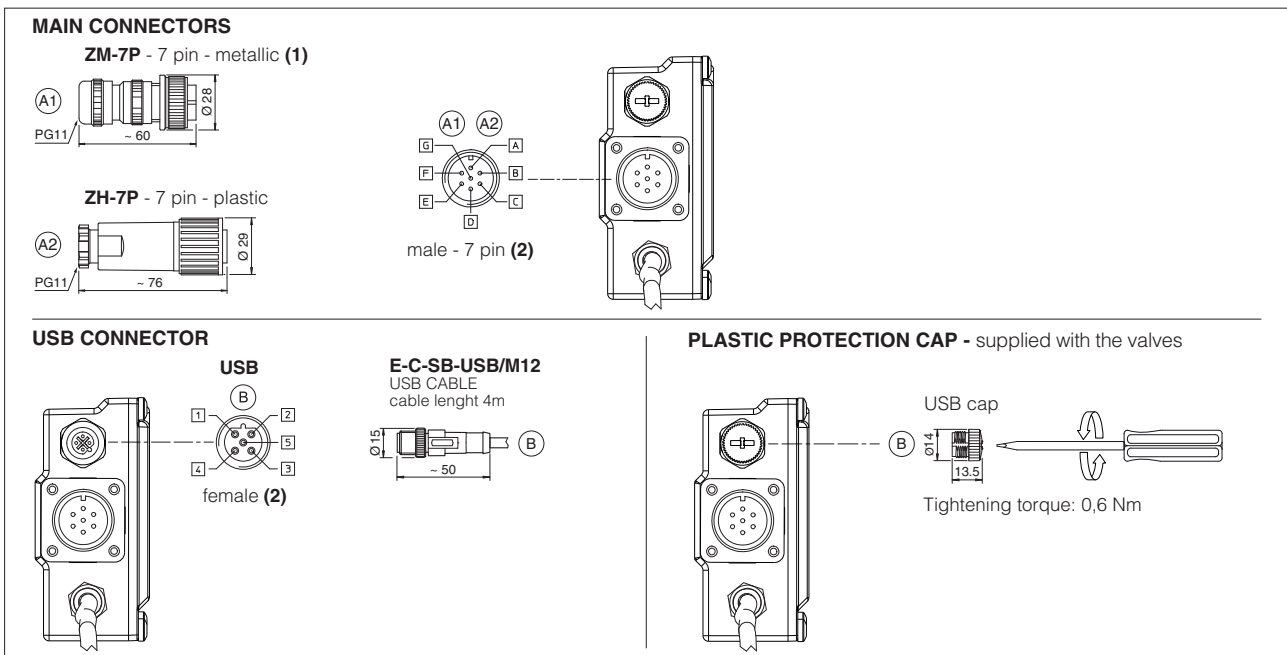

(1) use of metallic connectors is strongly recommended in order to fulfill EMC requirements (2) pin layout always referred to driver's view

13 CONNECTORS CHARACTERISTICS - to be ordered separately

CONNECTOR TYPE	POWER SUPPLY	
CODE	(A1) ZM-7P	(A2) ZH-7P
Type	7pin female straight circular	7pin female straight circular
Standard	According to MIL-C-5015	According to MIL-C-5015
Material	Metallic	Plastic reinforced with fiber glass
Cable gland	PG11	PG11
Recommended cable	LiYCY 7 x 0,75 mm ² max 20 m (logic and power supply) or LiYCY 7 x 1 mm ² max 40 m (logic and power supply)	LiYCY 7 x 0,75 mm ² max 20 m (logic and power supply) or LiYCY 7 x 1 mm ² max 40 m (logic and power supply)
Conductor size	up to 1 mm ² - available for 7 wires	up to 1 mm ² - available for 7 wires
Connection type	to solder	to solder
Protection (EN 60529)	IP 67	IP 67

14 FASTENING BOLTS AND SEALS

	SDHZE	SDKZE
	<p>Fastening bolts:</p> <p>4 socket head screws M5x30 class 12.9</p> <p>Tightening torque = 8 Nm</p>	<p>Fastening bolts:</p> <p>4 socket head screws M6x40 class 12.9</p> <p>Tightening torque = 15 Nm</p>
	<p>Seals:</p> <p>4 OR 108</p> <p>Diameter of ports A, B, P, T: Ø 7,5 mm (max)</p>	<p>Seals:</p> <p>5 OR 2050</p> <p>Diameter of ports A, B, P, T: Ø 11,2 mm (max)</p>

SDHZE-TID-NP-*

ISO 4401: 2000

Mounting surface: 4401-03-02-0-05

P, A, B, T = \varnothing 7,5 max

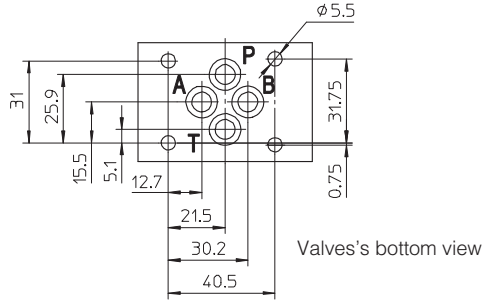

Valve	Mass [kg]
SDHZE-05*	2,5
SDHZE-07*	3

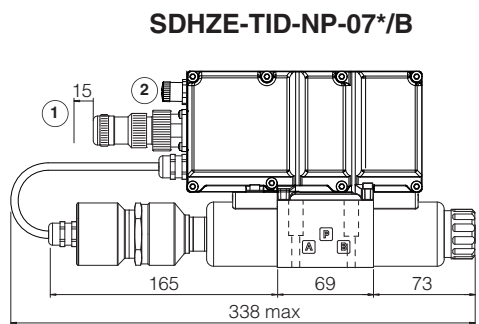
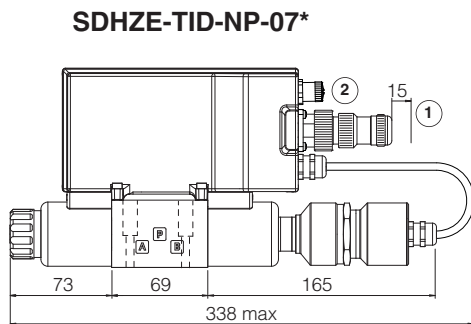
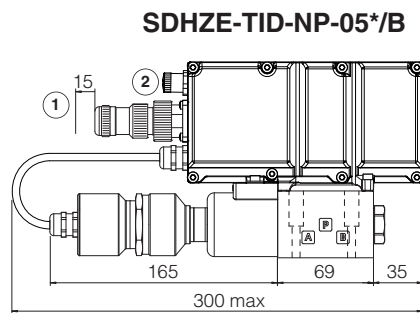
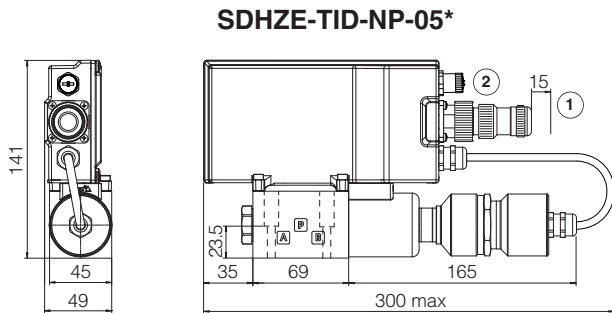

① = Space to remove the connectors

② = The dimensions of all connectors must be considered, see section 12.3

SDKZE-TID-NP-*

ISO 4401: 2000

Mounting surface: 4401-05-04-0-05

P, A, B, T = \varnothing 11,2 max

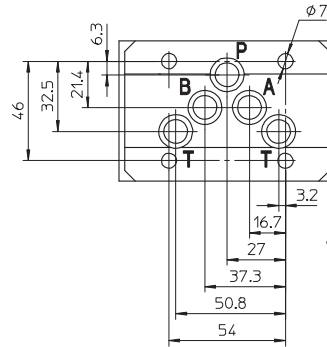

Valves's bottom view

Valve	Mass [kg]
SDKZE-15*	5,5
SDKZE-17*	7,1

SDKZE-TID-NP-15*

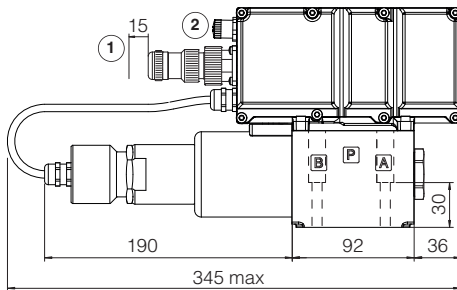

SDKZE-TID-NP-15*/B

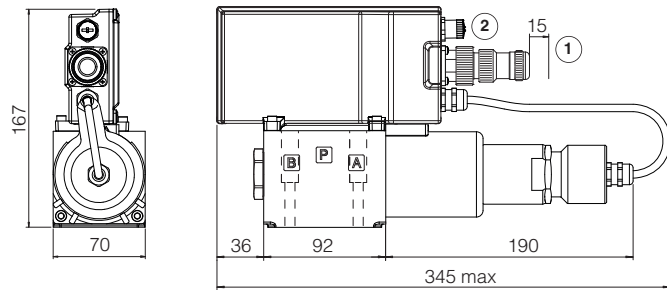

SDKZE-TID-NP-17*

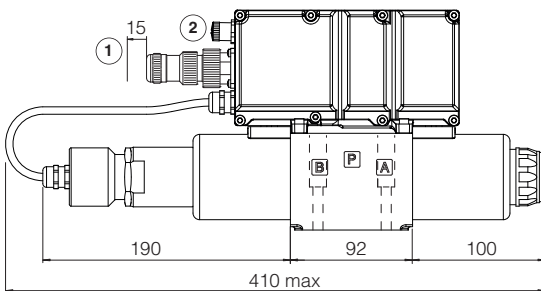

SDKZE-TID-NP-17*/B

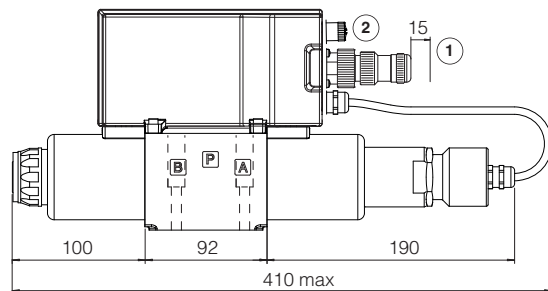

① = Space to remove the connectors

② = The dimensions of all connectors must be considered, see section 12.3