

Ex-proof proportional directional valves

direct, without transducer and with positive spool overlap - **ATEX, IECEX, EAC, PESO, CCC** or **cULus**

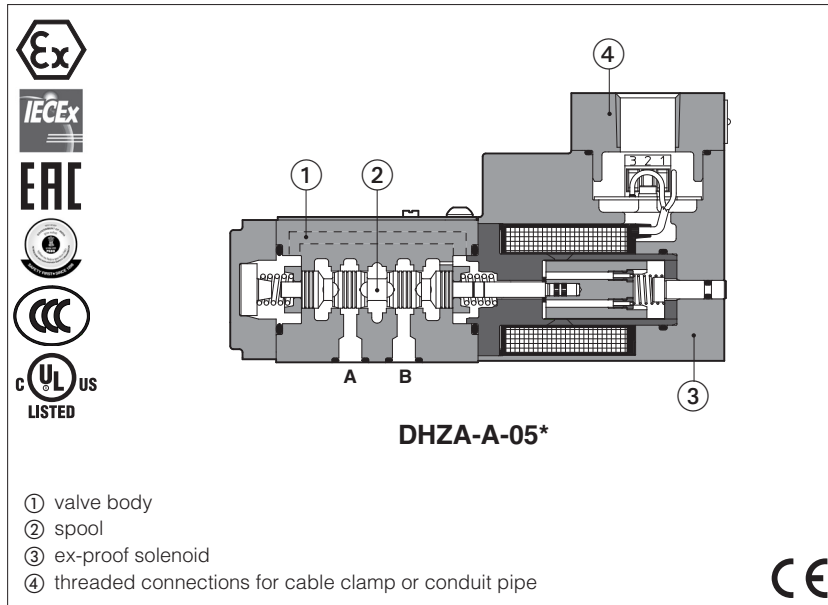

DHZA-A, DKZA-A

Ex-proof proportional valves direct, without position transducer and with positive spool overlap, for open loop directional controls and not compensated flow regulations.

They are equipped with ex-proof proportional solenoids certified for safe operations in hazardous environments with potentially explosive atmosphere.

Certifications:

- Multicertification **ATEX, IECEX, EAC, PESO, CCC** for gas group **II 2G** and dust category **II 2D**
- Multicertification **ATEX, IECEX**, for gas group **I M2** (mining)
- **cULus** North American certification for gas group **C&D**

The flameproof enclosure of solenoid prevents the propagation of accidental internal sparks or fire to the external environment.

The solenoid is also designed to limit the surface temperature within the classified limits.

DHZA:	DKZA:
Size: 06 - ISO 4401	Size: 10 - ISO 4401
Max flow: 60 l/min	Max flow: 120 l/min
Max pressure: 350 bar	Max pressure: 315 bar

1 MODEL CODE

DHZA	/	*	-	A	-	0	51	-	L	-	5	-	M	/	*	/	*	/	*
<p>Ex-proof proportional directional valves, direct</p> <p>DHZA = size 06 DKZA = size 10</p> <p>Certification type: Multicertification ATEX, IECEX, EAC, PESO, CCC: - = omit for Group II 2G / 2D (1) M = Group I M2 (mining) North American Certification: UL = cULus</p> <p>A = without transducer</p> <p>Valve size ISO 4401: 0 = 06 1 = 10</p>																			
<p>Seals material, see section 6:</p> <p>- = NBR PE = FKM BT = HNBR (2)</p> <p>Voltage code:</p> <p>- = standard coil for 24 Vdc Atos drivers 24 = optional coil for 24 Vdc low current drivers</p>																			
<p>Options (3):</p> <p>B = solenoid at side of port A MV = vertical hand lever (only for DHZA) (4) O = horizontal cable entrance (2) WP = manual override protected by metallic cap Y = external drain</p>																			

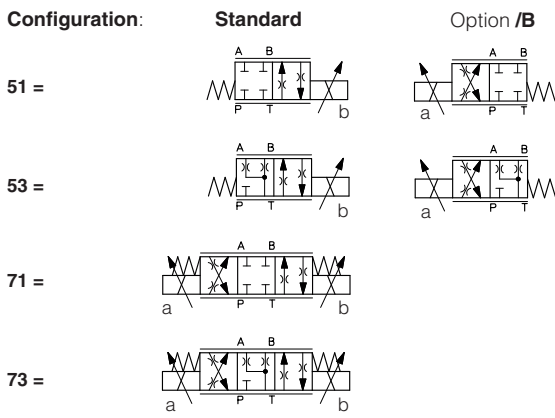

Solenoid threaded connection for cable gland fitting:

- GK** = GK-1/2" - not for **cULus** (5)
- M** = M20x1,5 - not for **cULus**
- NPT** = 1/2" NPT

Spool size:	14 (L)	1 (L)	2 (S)	3 (L,S,D)	5 (L,S,D)
DHZA =	1	4,5	8	18	28
DKZA =	-	-	-	45	60

Nominal flow (l/min) at Δp 10 bar P-T

Spool type - regulating characteristics:

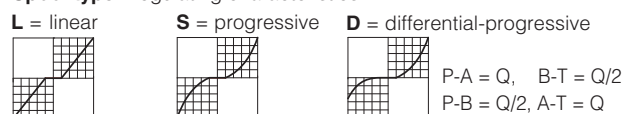

(1) The valves with Multicertification for Group II are also certified for Indian market according to **PESO** (Petroleum and Explosives Safety Organization). The PESO certificate can be downloaded from www.atos.com

(2) Not for multicertification **M** group I (mining) (3) Possible combined options: all combination are available, with exception of MV + WP

(4) MV option is available only for **DHZA** with spool type **S3, S5, D3, D5, L3, L5**, not available in combination with **WP** option

(5) Approved only for Italian market

⚠ The pressure at T port makes difficult the manual override operation that can be possible only if its value is lower than 50 bar

2 ELECTRONIC DRIVERS

Electronic drivers are factory set with max current limitation for ex-proof valves.

Please include in the driver order also the complete code of the connected ex-proof proportional valve.

Drivers model	E-BM-AS-* /A	E-BM-AES-* /A
Type	digital	digital
Format	DIN-rail panel	
Data sheet	G030	GS050

3 GENERAL CHARACTERISTICS

Assembly position	Any position
Subplate surface finishing to ISO 4401	Acceptable roughness index, Ra ≤0,8 recommended Ra 0,4 - flatness ratio 0,01/100
MTTFd valves according to EN ISO 13849	150 years, see technical table P007
Ambient temperature range	Standard = -20°C ÷ +70°C /PE option = -20°C ÷ +70°C /BT option = -40°C ÷ +70°C
Storage temperature range	Standard = -20°C ÷ +80°C /PE option = -20°C ÷ +80°C /BT option = -40°C ÷ +70°C
Surface protection	Zinc coating with black passivation - salt spray test (EN ISO 9227) > 200h
Compliance	Explosion proof protection, see section 7 -Flame proof enclosure "Ex d" -Dust ignition protection by enclosure "Ex t" RoHs Directive 2011/65/EU as last update by 2015/65/EU REACH Regulation (EC) n°1907/2006

4 HYDRAULIC CHARACTERISTICS - based on mineral oil ISO VG 46 at 50 °C

Valve model	DHZA						DKZA		
Pressure limits [bar]	ports P, A, B = 350; T = 210 (250 with external drain /Y); Y = 10						ports P, A, B = 315; T = 210 (250 with external drain /Y); Y = 10		
Configuration	51, 53, 71, 73					70	51, 53, 71, 73		70
Spool type	L14	L1	S2	L3,S3,D3	L5,S5,D5	L5	L3,S3,D3	L5,S5,D5	L3,L5,D5
Nominal flow [l/min]									
Δp P-T	Δp= 10 bar	1	4,5	8	18	28	45		60
	Δp= 30 bar	1,7	8	14	30	50	80		100
Max permissible flow	2,6	12	21	40	60	60	90		120
Δp max P-T [bar]	70	70	70	50	50	50	40		40
Response time (1) [ms]	≤ 35						≤ 45		
Leakage [cm³/min]	<30 (at p = 100 bar); <135 (at p = 350 bar)						<80 (at p = 100 bar); <600 (at p = 315 bar)		
Hysteresis	≤ 5 [% of max regulation]								
Repeatability	± 1 [% of max regulation]								

Note: above performance data refer to valves coupled with Atos electronic drivers, see section 3

(1) 0-100% step signal

5 ELECTRICAL CHARACTERISTICS

Max. power	35W	
Insulation class	H (180°) Due to the occurring surface temperatures of the solenoid coils, the European standards ISO 13732-1 and EN982 must be taken into account	
Protection degree with relevant cable gland	Multicertification: IP66/67 to DIN EN60529 UL: raintight enclosure, UL approved	
Duty factor	Continuous rating (ED=100%)	
Voltage code	standard	option /24
Coil resistance R at 20°C	3,2 Ω	17,6 Ω
Max. solenoid current	2,5 A	1,1 A

6 SEALS AND HYDRAULIC FLUIDS - for other fluids not included in below table, consult our technical office

Seals, recommended fluid temperature	NBR seals (standard) = -20°C ÷ +60°C, with HFC hydraulic fluids = -20°C ÷ +50°C FKM seals (/PE option) = -20°C ÷ +80°C HNBR seals (/BT option) = -40°C ÷ +60°C, with HFC hydraulic fluids = -40°C ÷ +50°C		
Recommended viscosity	20 ÷ 100 mm²/s - max allowed range 15 ÷ 380 mm²/s		
Max fluid contamination level	normal operation	ISO4406 class 18/16/13 NAS1638 class 7	see also filter section at
	longer life	ISO4406 class 16/14/11 NAS1638 class 5	www.atos.com or KTF catalog
Hydraulic fluid	Suitable seals type	Classification	Ref. Standard
Mineral oils	NBR, FKM, HNBR	HL, HLP, HLPD, HVLP, HVLPD	DIN 51524
Flame resistant without water	FKM	HFDU, HFDR	ISO 12922
Flame resistant with water (1)	NBR, HNBR	HFC	

 The ignition temperature of the hydraulic fluid must be 50°C higher than the max solenoid surface temperature

(1) **Performance limitations in case of flame resistant fluids with water:**

-max operating pressure = 210 bar

-max fluid temperature = 50°C

7 CERTIFICATION DATA

Valve type	DHZA, DKZA		DHZA/M, DKZA/M	DHZA/UL, DKZA/UL	
Certifications	Multicertification Group II ATEX, IECEX, EAC, PESO, CCC		Multicertification Group I ATEX, IECEX	North American cULus	
Solenoid certified code	OZA-A		OZAM-A	OZA-A/EC	
Type examination certificate (1)	ATEX: CESI 02 ATEX 014 IECEX: IECEX CES 10.0010x EAC: TC RU C-IT. 08.B.01784 PESO: P468212/2 CCC: 2020322307003240		ATEX: CESI 03 ATEX 057x IECEX: IECEX CES 12.0007x	20170324 - E366100	
Method of protection	<ul style="list-style-type: none"> • ATEX, EAC Ex II 2G Ex d IIC T4/T3 Gb Ex II 2D Ex tb IIIC T135°C/T200°C Db • IECEX Ex d IIC T4/T3 Gb Ex tb IIIC T135°C/T200°C Db • PESO Ex db IIC T4/T3 Gb • CCC Ex d IIC T4/T3 Gb Ex tD A21 IP66/IP67 T135°C/T200°C 		<ul style="list-style-type: none"> • ATEX Ex I M2 Ex db I Mb • IECEX Ex db I Mb 	<ul style="list-style-type: none"> • UL 1203 Class I, Div.I, Groups C & D Class I, Zone I, Groups IIA & IIB 	
Temperature class	T4	T3	-	T4	T3
Surface temperature	≤ 135 °C	≤ 200 °C	≤ 150 °C	≤ 135 °C	≤ 200 °C
Ambient temperature (2)	-40 ÷ +40 °C	-40 ÷ +70 °C	-20 ÷ +60 °C	-40 ÷ +55 °C	-40 ÷ +70 °C
Applicable standards	EN 60079-0 EN 60079-1 EN 60079-31		IEC 60079-0 IEC 60079-1 IEC 60079-31	UL 1203 and UL429, CSA 22.2 n°30 CSA 22.2 n°139-13	
Cable entrance: threaded connection vertical (standard) or horizontal (option /O)			GK = GK-1/2" M = M20x1,5 NPT = 1/2" NPT	1/2" NPT	

(1) The type examiner certificates can be downloaded from www.atos.com

(2) The solenoids **Group II** and **cULus** are certified for minimum ambient temperature -40°C

In case the complete valve must withstand with minimum ambient temperature of -40°C, select **/BT** in the model code

⚠ WARNING: service work performed on the valve by the end users or not qualified personnel invalidates the certification

8 EX PROOF SOLENOIDS WIRING

Multicertification

Standard version **Option /O**

① cover with threaded connection for vertical cable gland fitting
 ② cover with threaded connection for horizontal cable gland fitting
 ③ terminal board for cables wiring
 ④ standard manual override
 ⑤ screw terminal for additional equipotential grounding

1 = Coil
 2 = GND
 3 = Coil

 PCB 3 poles terminal board suitable for wires cross sections up to 2,5 mm² (max AWG14)

cULus certification

Standard version **Option /O**

① cover with threaded connection for vertical cable gland fitting
 ② cover with threaded connection for horizontal cable gland fitting
 ③ terminal board for cables wiring
 ④ standard manual override

⚠ Pay attention to respect the polarity

1 = Coil +
 2 = GND
 3 = Coil -

 PCB 3 poles terminal board suggested cable section up to 1,5 mm² (max AWG16), see section 9 note 1

alternative GND screw terminal connected to solenoid housing

9 CABLE SPECIFICATION AND TEMPERATURE - Power supply and grounding cables have to comply with following characteristics:

Multicertification Group I and Group II	
Power supply: section of coil connection wires = 2,5 mm ²	Grounding: section of internal ground wire = 2,5 mm ² section of external ground wire = 4 mm ²
cULus certification:	
<ul style="list-style-type: none"> Suitable for use in Class I Division 1, Gas Groups C Armored Marine Shipboard Cable which meets UL 1309 Tinned Stranded Copper Conductors Bronze braided armor Overall impervious sheath over the armor 	
Any Listed (UBVZ/UBVZ7) Marine Shipboard Cable rated 300 V min, 15A min. 3C 2,5 mm ² (14 AWG) having a suitable service temperature range of at least -25°C to +110°C ("BT" Models require a temperature range from -40°C to +110°C)	
Note 1: For Class I wiring the 3C 1,5 mm ² AWG 16 cable size is admitted only if a fuse lower than 10 A is connected to the load side of the solenoid wiring.	

9.1 Cable temperature

The cable must be suitable for the working temperature as specified in the "safety instructions" delivered with the first supply of the products.

Multicertification

Max ambient temperature [°C]	Temperature class		Max surface temperature [°C]		Min. cable temperature [°C]	
	Goup I	Goup II	Goup I	Goup II	Goup I	Goup II
40 °C	-	T4	150 °C	135 °C	90 °C	90 °C
45 °C	-	T4	-	135 °C	-	95 °C
55 °C	-	T3	-	200 °C	-	110 °C
60 °C	-	-	150 °C	-	110 °C	-
70 °C	N.A.	T3	N.A.	200 °C	N.A.	120 °C

cULus certification

Max ambient temperature [°C]	Temperature class	Max surface temperature [°C]	Min. cable temperature
55 °C	T4	135 °C	100 °C
70 °C	T3	200 °C	100 °C

10 CABLE GLANDS - only **Multicertification**

Cable glands with threaded connections GK-1/2", 1/2"NPT or M20x1,5 for standard or armoured cables have to be ordered separately, see tech. table **KX800**

Note: a Loctite sealant type 545, should be used on the cable gland entry threads

11 OPTIONS

B = Solenoid at side of port A of the main stage

MV = Auxiliary vertical hand levers (only for DHZA)

This option allows to operate the valves in absence of electrical power supply, i.e. during commissioning, maintenance or in case of emergency.

When the valve is electrically operated the hand lever remains stopped in its rest position

The hand lever execution does not affect the performances of the original valves

Total angle stroke	[°deg]	± 28°	Lever actuating force	[N]	1 ÷ 8
Working angle stroke	[°deg]	± 15°	Lever device weight	[g]	880

O = Horizontal cable entrance, to be selected in case of limited vertical space

WP = Manual override protect by metallic cap.

Y = External drain, to be selected if the pressure at T port is higher than the max allowed limits

11.1 Possible combined options: all combination are available

12 DIAGRAMS - based on mineral oil ISO VG 46 at 50 °C

Regulation diagrams - values measure at Δp 30 bar P-T

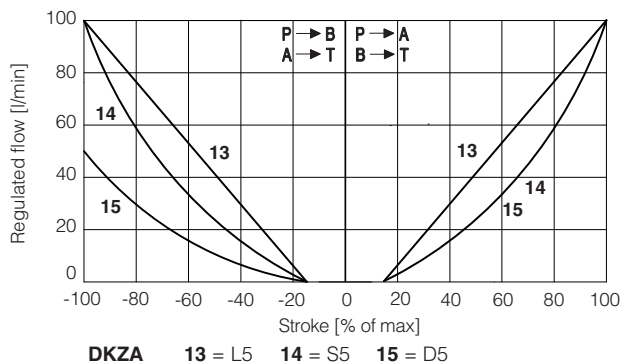
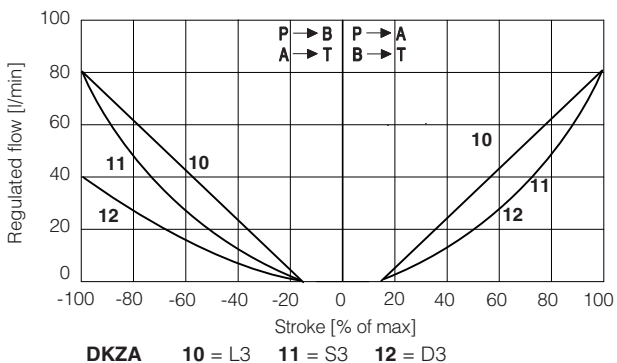
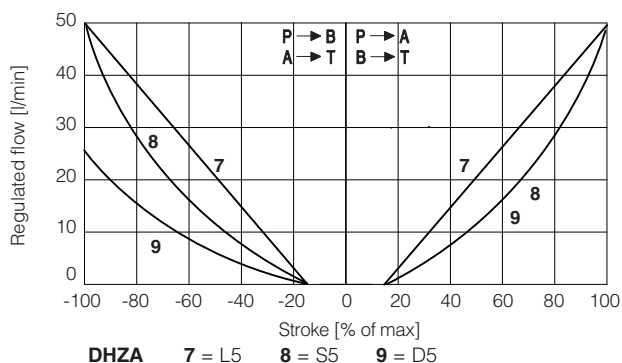
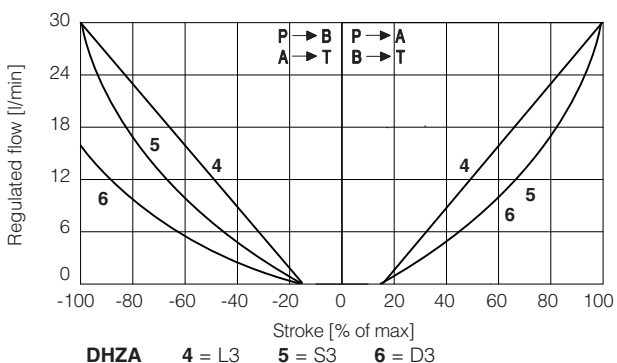
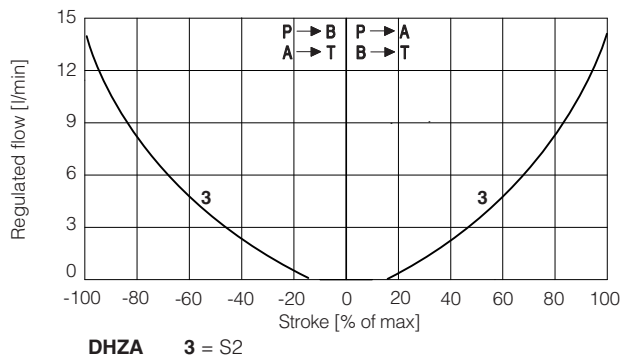
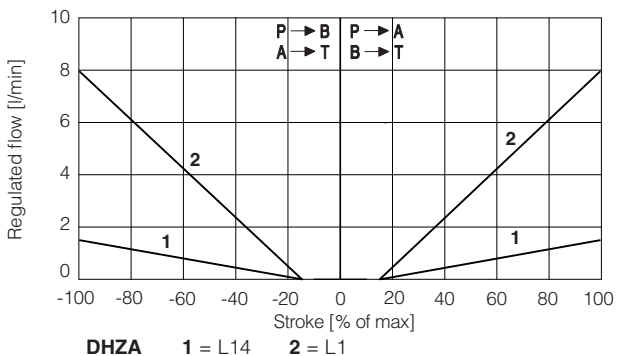

13 FASTENING BOLTS AND SEALS

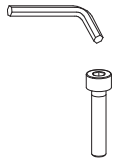
	<p>DHZA</p> <p>Fastening bolts: 4 socket head screws M5x50 class 12.9 Tightening torque = 8 Nm</p>	<p>DKZA</p> <p>Fastening bolts: 4 socket head screws M6x40 class 12.9 Tightening torque = 15 Nm</p>
	<p>Seals: 4 OR 108; Diameter of ports P, A, B, T: \varnothing 7,5 mm (max) 1 OR 2025 Diameter of port Y: \varnothing = 3,2 mm (only for /Y option)</p>	

14 INSTALLATION DIMENSIONS FOR DHZA [mm]

ISO 4401: 2005 (see table P005)
 Mounting surface: 4401-03-02-0-05
 (for /Y surface: 4401-03-03-0-05 without port X)

Mass [kg]	
DHZA-A-05	2,65
DHZA-A-07	4,3
Option /O	+0,35
Option /WP	+0,25

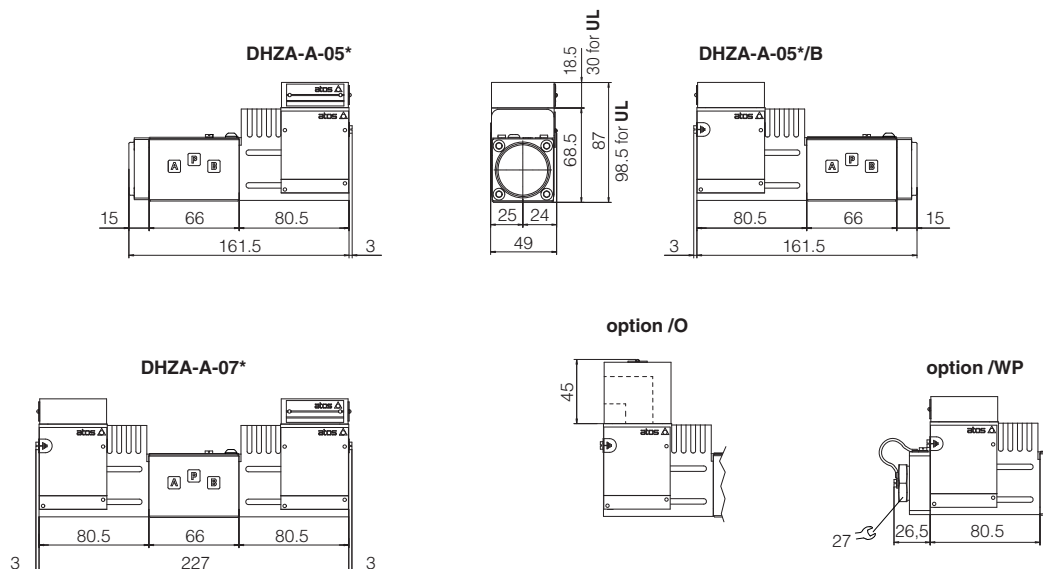

15 INSTALLATION DIMENSIONS FOR DKZA [mm]

ISO 4401: 2005 (see table P005)
 Mounting surface: 4401-05-04-0-05
 (for /Y surface: 4401-05-05-0-05 without port X)

Mass [kg]	
DKZA-A-15	4,8
DKZA-A-17	6,5
Option /O	+0,35
Option /WP	+0,25

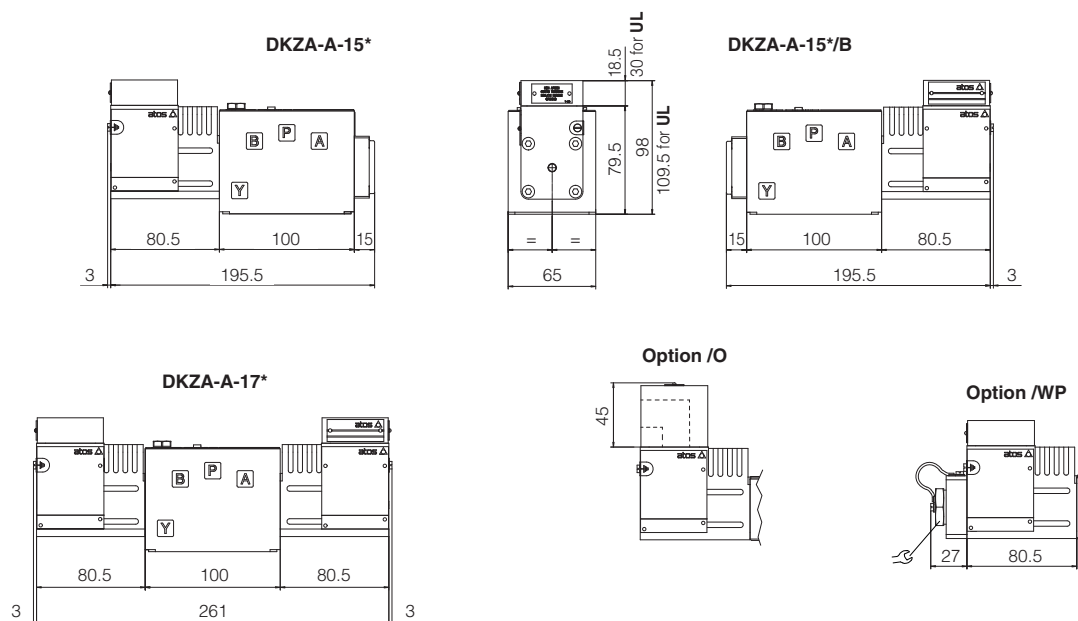

16 INSTALLATION DIMENSIONS FOR DHZA WITH OPTION /MV [mm]

ISO 4401: 2005 (see table P005)
 Mounting surface: 4401-03-02-0-05
 (for /Y surface: 4401-03-03-0-05 without port X)

Mass [kg]	
DHZA-A-05	2,9
DHZA-A-07	4,6
Option /O	+0,35

DHZA-A-05*/MV

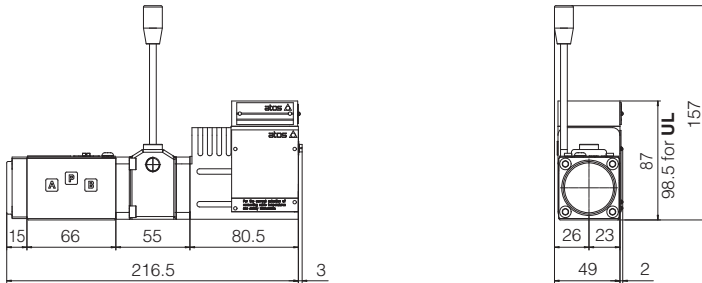

DHZA-A-05*/BMV

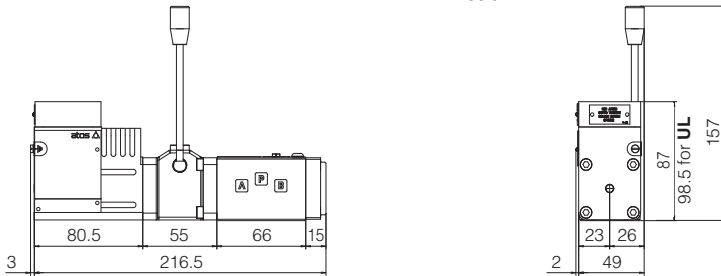

option /O

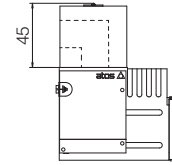

DHZA-A-07*/MV

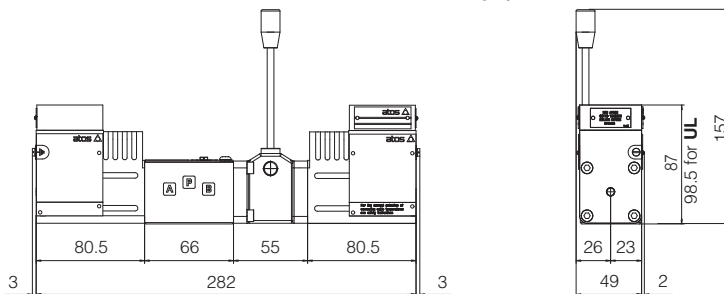

DHZA-A-07*/BMV

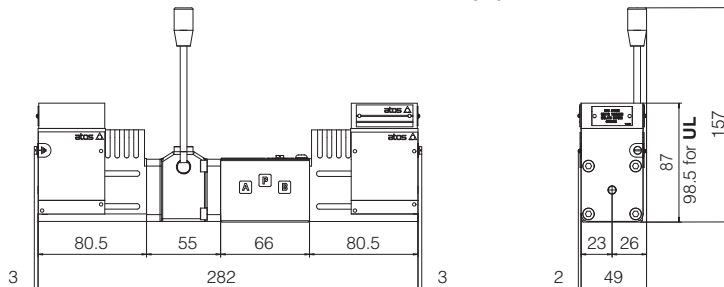

17 RELATED DOCUMENTATION

- X010** Basics for electrohydraulics in hazardous environments
- X020** Summary of Atos ex-proof components certified to ATEX, IECEX, EAC, CCC, PESO
- X030** Summary of Atos ex-proof components certified to cULus
- FX900** Operating and maintenance information for ex-proof proportional valves
- KX800** Cable glands for ex-proof valves
- P005** Mounting surfaces for electrohydraulic valves