

# Ex-proof digital servoproportional directional valves

piloted, with on-board driver, two LVDT transducers and zero spool overlap - **ATEX, IECEx, EAC, CCC**

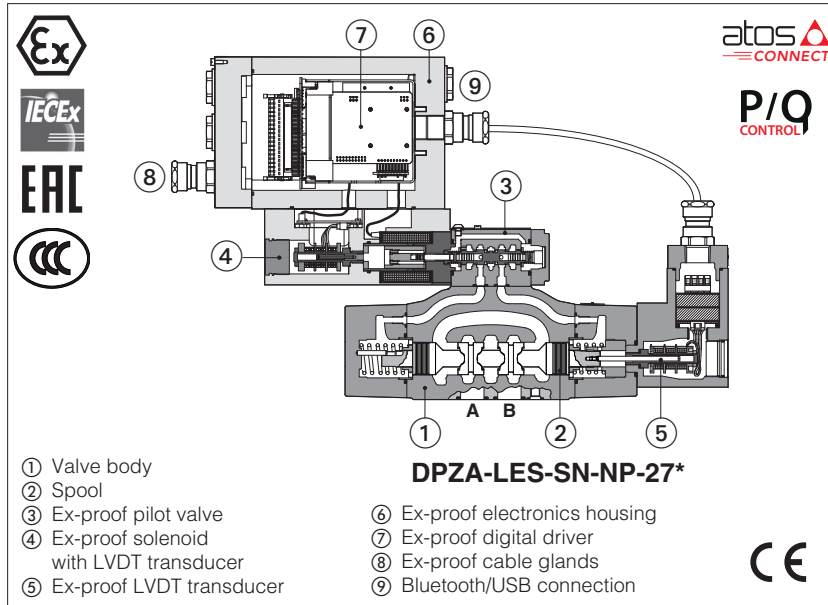

## DPZA-LES

Ex-proof digital servoproportional directional valves, piloted with two LVDT position transducers (pilot valve and main stage) and zero spool overlap for position closed loop controls.

They are equipped with ex-proof on-board digital driver, LVDT transducer and proportional solenoid certified for safe operations in hazardous environments with potentially explosive atmosphere.

- Multicertification **ATEX, IECEx, EAC, CCC** for gas group **II 2G** and dust category **II 2D**

The flameproof enclosure of on-board digital driver, solenoid and transducers, prevents the propagation of accidental internal sparks or fire to the external environment. The driver and solenoid are also designed to limit the surface temperature within the classified limits.

LEZ execution includes valve driver plus axis card to perform position control (see section 8).

Size: **10 ÷ 27** -ISO4401

Max flow: **180 ÷ 800 l/min**

Max pressure: **350 bar**

## 1 MODEL CODE

<b>DPZA</b>	-	<b>LES</b>	-	<b>SN</b>	-	<b>NP</b>	-	<b>2</b>		<b>70</b>	-	<b>L</b>		<b>5</b>	/	<b>M</b>	/	<b>*</b>		/	<b>*</b>	
<p>Ex-proof proportional directional valve, piloted</p> <p><b>LES</b> = on-board driver and two LVDT transducers</p> <p><b>Alternated p/Q controls</b>, see section 5:  <b>SN</b> = none  <b>SP</b> = pressure control (1 pressure transducer)  <b>SF</b> = force control (2 pressure transducers)  <b>SL</b> = force control (1 load cell)</p> <p><b>Fieldbus interface</b>, see section 4:  <b>NP</b> = Not Present  <b>BC</b> = CANopen      <b>EW</b> = POWERLINK  <b>BP</b> = PROFIBUS DP    <b>EI</b> = EtherNet/IP  <b>EH</b> = EtherCAT      <b>EP</b> = PROFINET RT/IRT</p> <p><b>Valve size ISO 4401:</b>  <b>1</b> = 10    <b>2</b> = 16    <b>4</b> = 25    <b>4M</b> = 27</p>																						
																			<p>Series number</p>		<p><b>Seals material</b>, see section 8:          - = NBR  <b>PE</b> = FKM  <b>BT</b> = NBR low temp.</p>	
																			<p><b>Hydraulic options (1):</b>  <b>B</b> = solenoid at side of port A (2)  <b>D</b> = internal drain  <b>E</b> = external pilot pressure  <b>G</b> = pressure reducing valve for piloting (standard for size 10)</p>		<p><b>Electronic options (1):</b>  <b>C</b> = current feedback for pressure transducer 4 ÷ 20 mA (only for TES-SP, SF, SL)  <b>I</b> = current reference input and monitor 4 ÷ 20 mA</p>	
																			<p><b>Cable entrance threaded connection:</b>  <b>M</b> = M20x1,5</p>			
																			<p><b>Spool size</b>      <b>3 (L)</b>      <b>5 (L,DL)</b>      <b>5 (T)</b></p>			
																			<p>DPZA-1 = -      100      -</p>			
																			<p>DPZA-2 = 130      200      150</p>			
																			<p>DPZA-4 = -      340      -</p>			
																			<p>DPZA-4M = -      390      -</p>			
																			<p>Nominal flow (l/min) at Δp 10bar P-T, see section 8</p>			

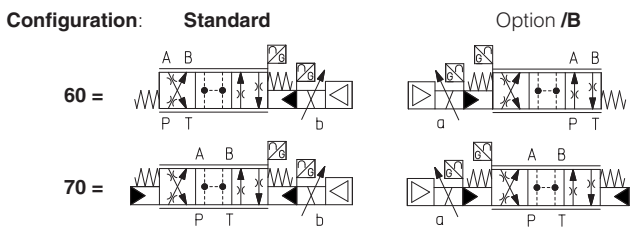

(1) For possible combined options, see section 16  
 (2) In standard configuration the solenoid with on-board digital driver and position transducer are at side A of main stage (side B of pilot valve)  
 (3) only for configuration 70

## 2 GENERAL NOTES

Atos digital proportionals valves are CE marked according to the applicable directives (e.g. Immunity and Emission EMC Directive). Installation, wirings and start-up procedures must be performed according to the general prescriptions shown in tech table **FX900** and in the user manuals included in the E-SW-SETUP programming software.

## 3 VALVE SETTINGS AND PROGRAMMING TOOLS - see tech. table **GS500**

**WARNING:** the below operation must be performed in a safety area!

### 3.1 Atos CONNECT mobile App

Free downloadable App for smartphones and tablets which allows quick access to valve main functional parameters and basic diagnostic information via Bluetooth, thus avoiding physical cable connection and significantly reducing commissioning time. Atos CONNECT supports Atos digital valve drivers equipped with E-A-BTH adapter or with built-in Bluetooth. It does not support valves with p/Q control or axis controls.



### 3.2 E-SW-SETUP PC software

Free downloadable software for PC allows to set all valve functional parameters and to access complete diagnostic information of digital valve drivers via Bluetooth/USB service port. Atos E-SW-SETUP PC software supports all Atos digital valve drivers and it is available at [www.atos.com](http://www.atos.com) in MyAtos area.

**WARNING:** drivers **USB port is not isolated!** For E-C-SB-USB/M12 cable, the use of E-A-SB-USB/OPT isolator adapter is highly recommended for PC protection

**WARNING:** for the list of countries where the Bluetooth adapter has been approved, see tech. table **GS500**

### Bluetooth or USB connection

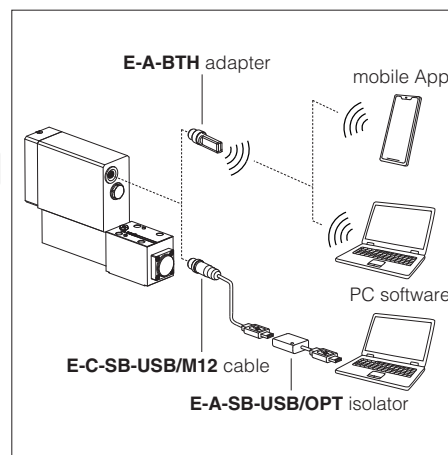

## 4 FIELDBUS - see tech. table **GS510**

Fieldbus allows valve direct communication with machine control unit for digital reference, valve diagnostics and settings. These executions allow to operate the valves through fieldbus or analog signals available on the terminal board.

## 5 ALTERNATED p/Q CONTROLS - see tech. table **FX500**

**S\*** options add the closed loop control of pressure (**SP**) or force (**SF** and **SL**) to the basic functions of proportional directional valves flow regulation. A dedicated algorithm alternates pressure (force) depending on the actual hydraulic system conditions.

An additional connector is available for transducers to be interfaced to the valve's driver (1 pressure transducer for SP, 2 pressure transducers for SF or 1 load cell for SL). The alternated pressure control (SP) is possible only for specific installation conditions.

## 6 AXIS CONTROLLER - see tech. table **FX630**

Digital servoproportional with integral electronics **LEZ** include valve's driver plus axis controller, performing position closed loop of any hydraulic actuator equipped with analog, encoder or SSI position transducer. Alternated pressure or force closed loop control can be set by software additionally to the position control.

Atos also supplies complete servoactuators integrating servocylinder, digital servoproportional valve and axis controller, fully assembled and tested. For more information consult Atos Technical Office.

## 7 GENERAL CHARACTERISTICS

Assembly position	Any position
Subplate surface finishing to ISO 4401	Acceptable roughness index, Ra ≤0,8 recommended Ra 0,4 - flatness ratio 0,01/100
MTTFd values according to EN ISO 13849	75 years, for further details see technical table P007
Ambient temperature range	<b>Standard</b> = -20°C ÷ +60°C <b>/PE</b> option = -20°C ÷ +60°C <b>/BT</b> option = -40°C ÷ +60°C
Storage temperature range	<b>Standard</b> = -20°C ÷ +70°C <b>/PE</b> option = -20°C ÷ +70°C <b>/BT</b> option = -40°C ÷ +70°C
Surface protection	Zinc coating with black passivation
Corrosion resistance	Salt spray test (ISO 9227) > 200 h
Vibration resistance	See technical table GX004
Compliance	Explosion proof protection, see section <b>11</b> -Flame proof enclosure "Ex d" -Dust ignition protection by enclosure "Ex t" RoHs Directive 2011/65/EU as last update by 2015/863/EU REACH Regulation (EC) n°1907/2006

**8 HYDRAULIC CHARACTERISTICS** - based on mineral oil ISO VG 46 at 50 °C

Valve model	DPZA-*-1	DPZA-*-2			DPZA-*-4	DPZA-*-4M	
Pressure limits [bar]	ports <b>P, A, B, X</b> = 350; <b>T</b> = 250 (10 for option /D); <b>Y</b> = 10;						
Spool type and size	<b>L5, DL5</b>	<b>L3</b>	<b>L5, DL5</b>	<b>T5</b>	<b>L5, DL5</b>		
Nominal flow [l/min]							
Δp P-T	Δp = 10 bar	100	130	200	150	340	390
	Δp = 30 bar	160	220	350	260	590	670
	Max permissible flow	180	320	440	360	680	800
Δp max P-T [bar]	50	60	60	60	60	60	
Piloting pressure [bar]	min. = 25; max = 350 (option /G advisable for pilot pressure > 200 bar)						
Piloting volume [cm³]	1,4	3,7			9,0	11,3	
Piloting flow <b>(1)</b> [l/min]	1,7	3,7			6,8	8	
Leakage <b>(2)</b>	Pilot [cm³/min]	100/300		150/450		200/600	200/600
	Main stage [l/min]	0,4/1,2		0,6/2,5		1,0/4,0	1,0/4,0
Response time <b>(1)</b> [ms]	≤ 30		≤ 30		≤ 35	≤ 40	
Hysteresis	≤ 0,1 [% of max regulation]						
Repeatability	± 0,1 [% of max regulation]						
Thermal drift	zero point displacement < 1% at ΔT = 40°C						

**(1)** 0 ÷ 100 % step signal and pilot pressure 100 bar

**(2)** at P = 100/350 bar

**9 ELECTRICAL CHARACTERISTICS**

Power supplies	Nominal : +24 VDC Rectified and filtered : VRMS = 20 ÷ 32 VMAX (ripple max 10 % VPP)			
Max power consumption	35 W			
Analog input signals	Voltage: range ±10 VDC (24 VMAX tolerant) Current: range ±20 mA		Input impedance: Ri > 50 kΩ Input impedance: Ri = 500 Ω	
Insulation class	H (180°) Due to the occurring surface temperatures of the solenoid coils, the European standards ISO 13732-1 and EN982 must be taken into account			
Monitor outputs	Output range: voltage ±10 VDC @ max 5 mA current ±20 mA @ max 500 Ω load resistance			
Enable input	Range: 0 ÷ 5 Vdc (OFF state), 9 ÷ 24 Vdc (ON state), 5 ÷ 9 Vdc (not accepted); Input impedance: Ri > 10 kΩ			
Fault output	Output range: 0 ÷ 24 Vdc (ON state > [power supply - 2 V] ; OFF state < 1 V ) @ max 50 mA; external negative voltage not allowed (e.g. due to inductive loads)			
Pressure transducer power supply	+24VDC @ max 100 mA (E-ATRA-7 see tech table <b>GX800</b> )			
Alarms	Solenoid not connected/short circuit, cable break with current reference signal, over/under temperature, valve spool transducer malfunctions, alarm history storage function			
Protection degree to DIN EN60529	IP66/67 with relevant cable gland			
Duty factor	Continuous rating (ED=100%)			
Tropicalization	Tropical coating on electronics PCB			
Additional characteristics	Short circuit protection of solenoid current supply; spool position control (SN) or pressure/force control (SP, SF, SL) P.I.D. with rapid solenoid switching; protection against reverse polarity of power supply			
Electromagnetic compatibility (EMC)	According to Directive 2014/30/UE (Immunity: EN 61000-6-2; Emission: EN 61000-6-3)			
Communication interface	USB	CANopen	PROFIBUS DP	EtherCAT, POWERLINK, EtherNet/IP, PROFINET IO RT / IRT EC 61158
	Atos ASCII coding	EN50325-4 + DS408	EN50170-2/IEC61158	EC 61158
Communication physical layer	not insulated USB 2.0 + USB OTG	optical insulated CAN ISO11898	optical insulated RS485	Fast Ethernet, insulated 100 Base TX

**Note:** a maximum time of 800 ms (depending on communication type) has to be considered between the driver energizing with the 24 VDC power supply and when the valve is ready to operate. During this time the current to the valve coils is switched to zero

**10 SEALS AND HYDRAULIC FLUIDS** - for other fluids not included in below table, consult our technical office

Seals, recommended fluid temperature	NBR seals (standard) = -20°C ÷ +60°C, with HFC hydraulic fluids = -20°C ÷ +50°C FKM seals (/PE option) = -20°C ÷ +80°C NBR low temp. seals (/BT option) = -40°C ÷ +60°C, with HFC hydraulic fluids = -20°C ÷ +50°C		
Recommended viscosity	20 ÷ 100 mm²/s - max allowed range 15 ÷ 380 mm²/s		
Max fluid contamination level	normal operation	ISO4406 class 18/16/13 NAS1638 class 7	see also filter section at
	longer life	ISO4406 class 16/14/11 NAS1638 class 5	www.atos.com or KTF catalog
<b>Hydraulic fluid</b>	<b>Suitable seals type</b>	<b>Classification</b>	<b>Ref. Standard</b>
Mineral oils	NBR, FKM, NBR low temp.	HL, HLP, HLPD, HVLP, HVLPD	DIN 51524
Flame resistant without water	FKM	HF DU, HF DR	ISO 12922
Flame resistant with water <b>(1)</b>	NBR, NBR low temp.	HFC	

 The ignition temperature of the hydraulic fluid must be 50°C higher than the max solenoid surface temperature

**(1) Performance limitations in case of flame resistant fluids with water:**

- max operating pressure = 210 bar
- max fluid temperature = 50°C

## 11 CERTIFICATION DATA

Valve type	DHZA, DKZA		
Certifications	Multicertification Group II <b>ATEX IECEx EAC CCC</b>		
Solenoid, transducer	Solenoid	Transducer	
Solenoid and transducer certified code	<b>OZA-LES</b>	<b>ETHA-4/*</b>	
Type examination certificate (1)	<ul style="list-style-type: none"> <li>• ATEX: TUV IT 18 ATEX 068 X</li> <li>• IECEx: IECEx TPS 19.0004X</li> <li>• EAC:RU C - IT.AK38.B.00425/21</li> <li>• CCC: 2021322307004057</li> </ul>	<ul style="list-style-type: none"> <li>• ATEX: CESI 02 ATEX 015X / 06</li> <li>• IECEx: IECEx CES 12.006X</li> <li>• EAC:RU C - IT.AK38.B.00425/21</li> <li>• CCC: 2024322315005904</li> </ul>	
Method of protection	<ul style="list-style-type: none"> <li>• ATEX: Ex II 2G Ex db IIC T6/T5/T4 Gb; Ex II 2D Ex tb IIIC T85°C/T100°C/T135°C Db</li> <li>• IECEx: Ex db IIC T6/T5/T4 Gb; Ex tb IIIC T85°C/T100°C/T135°C Db</li> <li>• EAC: 1Ex d IIC T6/T5/T4 Gb X; Ex tb IIIC T85°C/T100°C/T135°C Db X</li> <li>• CCC: Ex d IIC T6/T5/T4 Gb; Ex tD A21 IP66/IP67 T85°C/T100°C/T135°C</li> </ul>	<ul style="list-style-type: none"> <li>• ATEX: Ex II 2G Ex db IIC T6/T5/T4 Gb; Ex II 2D Ex tb IIIC T85°C/T100°C/135°C Db</li> <li>• IECEx, CCC: Ex db IIC T6/T5/T4 Gb; Ex tb IIIC T85°C/T100°C/135°C Db</li> <li>• EAC: 1Ex d IIC T4/T3 Gb X; Ex tb IIIC T135°C/T200°C Db X</li> </ul>	
Temperature class	<b>T6</b>	<b>T5</b>	<b>T4</b>
Surface temperature	≤ 85 °C	≤ 100 °C	≤ 135 °C
Ambient temperature (2)	-40 ÷ +40 °C	-40 ÷ +55 °C	-40 ÷ +70 °C
Applicable Standards	EN 60079-0 IEC 60079-0	EN 60079-1 IEC 60079-31	EN 60079-31 IEC 60079-1
Cable entrance: threaded connection	<b>M</b> = M20x1,5		

(1) The type examination certificates can be downloaded from [www.atos.com](http://www.atos.com)

(2) The driver and solenoids are certified for minimum ambient temperature -40°C.

In case the complete valve must withstand with minimum ambient temperature -40°C, select **/BT** in the model code.

**⚠ WARNING: service work performed on the valve by the end users or not qualified personnel invalidates the certification.**

## 12 CABLE SPECIFICATION AND TEMPERATURE - Power supply and grounding cables have to comply with following characteristics:

**Power supply and signals:** section of wire = 1,0 mm<sup>2</sup>

**Grounding:** section of external ground wire = 4 mm<sup>2</sup>

### 12.1 Cable temperature

The cable must be suitable for the working temperature as specified in the "safety instructions" delivered with the first supply of the products.

Max ambient temperature [°C]	Temperature class	Max surface temperature [°C]	Min. cable temperature [°C]
40 °C	T6	85 °C	80 °C
55 °C	T5	100 °C	90 °C
70 °C	T4	135 °C	110 °C

## 13 CABLE GLANDS

Cable glands with threaded connections M20x1,5 for standard or armoured cables have to be ordered separately, see tech table **KX800**

**Note:** a Loctite sealant type 545, should be used on the cable gland entry threads

## 14 HYDRAULIC OPTIONS

**B** = Solenoid, integral electronics and position transducer at side of port B of the main stage.

**D** and **E** = Pilot and drain configuration can be modified as shown in section 21.

The valve's standard configuration provides internal pilot and external drain.

For different pilot / drain configuration select:

Option /D Internal drain.

Option /E External pilot (through port X).

**G** = Pressure reducing valve installed between pilot valve and main body with fixed setting:

DPZA-2 = 28 bar

DPZA-1, -4 and -4M = 40 bar

It is advisable for valves with internal pilot in case of system pressure higher than 150 bar.

Pressure reducing valve is standard for DPZA-1, for other sizes add **/G** option.

**FUNCTIONAL SCHEME**  
example of configuration 70

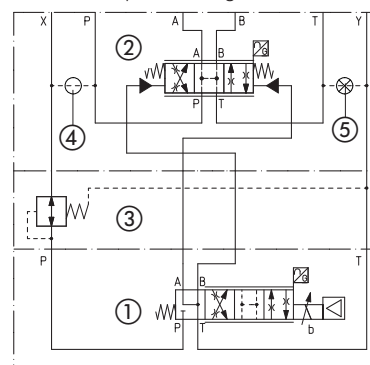

① Pilot valve

② Main stage

③ Pressure reducing valve

④ Plug to be added for external pilot through port X

⑤ Plug to be removed for internal drain through port T

## 15 ELECTRONIC OPTIONS

**I** = It provides 4 ÷ 20 mA current reference signal, instead of the standard ±10 VDC.

Input signal can be reconfigured via software selecting between voltage and current, within a maximum range of ±10 VDC or ±20 mA.

It is normally used in case of long distance between the machine control unit and the valve or where the reference signal can be affected by electrical noise; the valve functioning is disabled in case of reference signal cable breakage.

**C** = Only for **SP, SF, SL**

Option /C is available to connect pressure (force) transducers with 4 ÷ 20 mA current output signal, instead of the standard ±10 VDC.

Input signal can be reconfigured via software selecting between voltage and current, within a maximum range of ±10 VDC or ±20 mA.

## 16 POSSIBLE COMBINED OPTIONS

**Hydraulic options:** all combination possible

**Electronics options:** /CI (only for **SP, SF, SL**)

**17 DIAGRAMS** (based on mineral oil ISO VG 46 at 50 °C)

**17.1 Regulation diagrams** (values measure at  $\Delta p$  10 bar P-T)

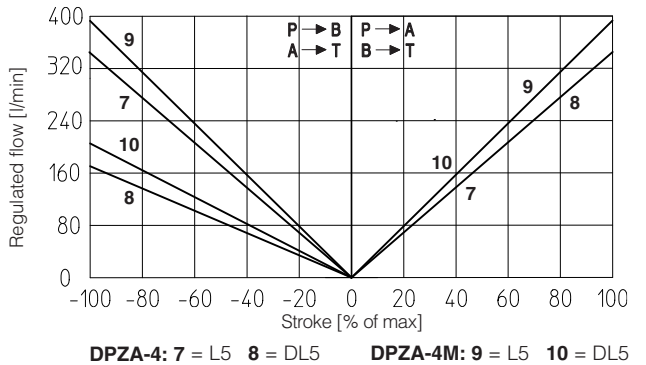
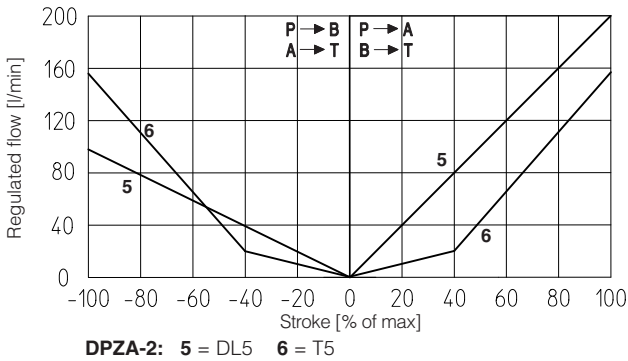
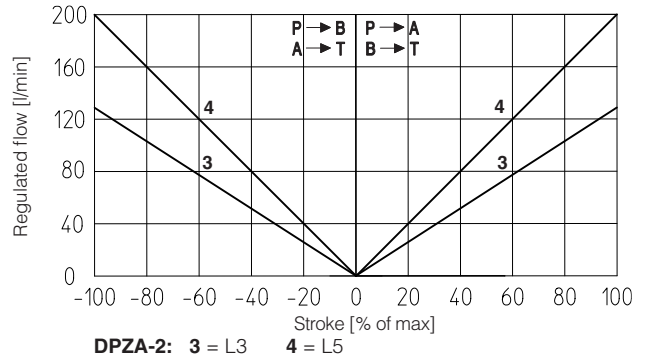
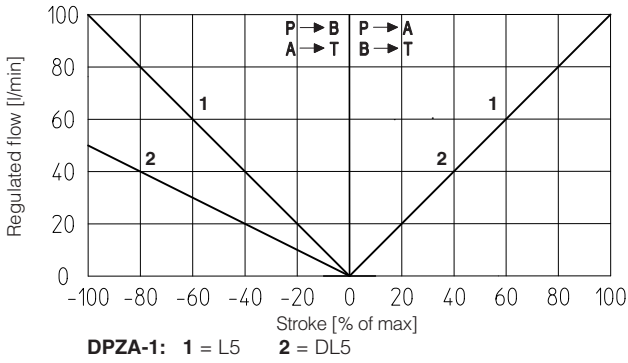

**Note:** Hydraulic configuration vs. reference signal for configurations 60 and 70 (standard and option /B)

Reference signal  $\left. \begin{matrix} 0 \div +10 \text{ V} \\ 12 \div 20 \text{ mA} \end{matrix} \right\} P \rightarrow A / B \rightarrow T$     Reference signal  $\left. \begin{matrix} 0 \div -10 \text{ V} \\ 4 \div 12 \text{ mA} \end{matrix} \right\} P \rightarrow B / A \rightarrow T$

**17.2 Bode diagrams**

Stated at nominal hydraulic conditions.

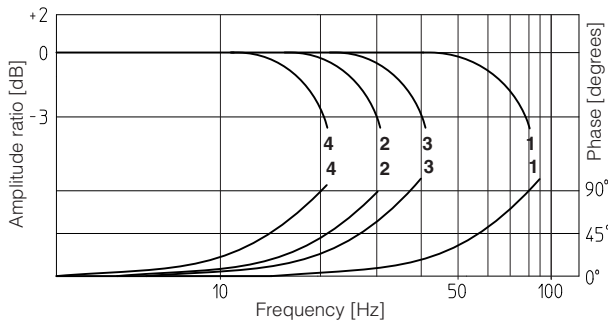

1 = DPZA-1 } ± 5%      2 = DPZA-1 } ± 100%  
 DPZA-2 } ± 100%  
 3 = DPZA-4 } ± 5%      4 = DPZA-4 } ± 100%  
 DPZA-4M } ± 100%

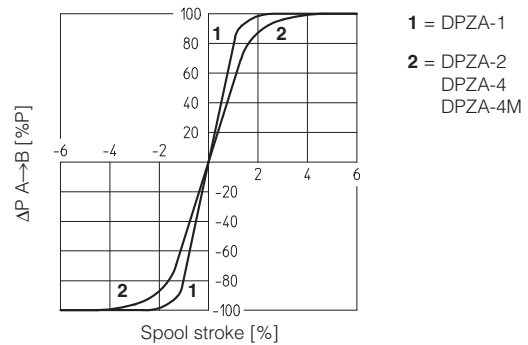

**17.3 Pressure gain**

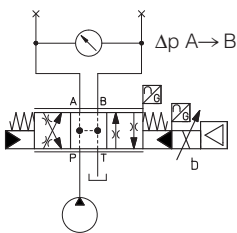

**17.4 Safety rest position - configuration 70**

In absence of electric power supply (+24 VDC), the valve main spool is moved by the springs force to the **central safety rest position** characterized by a small offset of about 1% to 6% of the total stroke in P-B / A-T configuration.

This is specifically designed to avoid that in case of accidental interruption of the electrical power supply to the valve, the actuator moves towards an undefined direction (due to the tolerances of the zero overlap spool), with potential risk of damages or personnel injury.

Thanks to the **central safety rest position** the actuator movement is suddenly stopped and it is recovered at very low speed towards the direction corresponding to the P-B/ A-T connection.

The main spool moves to the closed loop control position (zero overlap) when the pilot pressure is activated, the valve is fed with power supply +24 Vdc and reference input = 0V (or 12 mA for option /I) is applied to the driver.

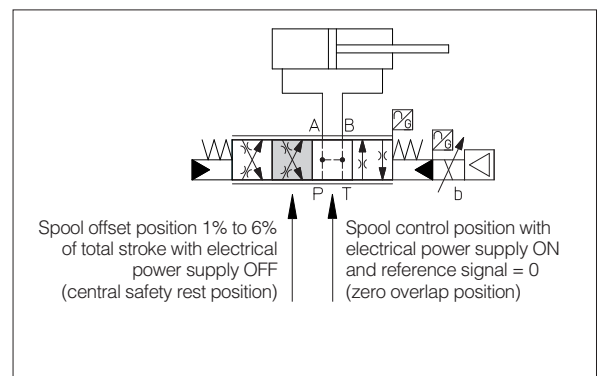

## 18 POWER SUPPLY AND SIGNALS SPECIFICATIONS

Generic electrical output signals of the valve (e.g. fault or monitor signals) must not be directly used to activate safety functions, like to switch-ON/OFF the machine's safety components, as prescribed by the European standards (Safety requirements of fluid technology systems and components-hydraulics, ISO 4413).

### 18.1 Power supply (V+ and V0)

The power supply must be appropriately stabilized or rectified and filtered: apply at least a 10000  $\mu$ F/40 V capacitance to single phase rectifiers or a 4700  $\mu$ F/40 V capacitance to three phase rectifiers.

 A safety fuse is required in series to each power supply: 2,5 A time lag fuse.

### 18.2 Power supply for driver's logic and communication (VL+ and VL0)

The power supply for driver's logic and communication must be appropriately stabilized or rectified and filtered: apply at least a 10000  $\mu$ F/40 V capacitance to single phase rectifiers or a 4700  $\mu$ F/40 V capacitance to three phase rectifiers.

The separate power supply for driver's logic on pin 3 and 4, allow to remove solenoid power supply from pin 1 and 2 maintaining active the diagnostics, USB and fieldbus communications.

 A safety fuse is required in series to each driver's logic and communication power supply: 500 mA fast fuse.

### 18.3 Flow reference input signal (Q\_INPUT+)

The driver controls in closed loop the valve spool position proportionally to the external reference input signal.

Reference input signal is factory preset according to selected valve code, defaults are  $\pm 10$  Vdc for standard and  $4 \div 20$  mA for /I option.

Input signal can be reconfigured via software selecting between voltage and current, within a maximum range of  $\pm 10$  VDC or  $\pm 20$  mA.

Drivers with fieldbus interface can be software set to receive reference signal directly from the machine control unit (fieldbus reference). Analog reference input signal can be used as on-off commands with input range  $0 \div 24$ VDC.

### 18.4 Pressure or force reference input signal (F\_INPUT+) - only SP, SF, SL

Functionality of F\_INPUT+ signal (pin 12), is used as reference for the driver pressure/force closed loop (see tech. table FX500).

Reference input signal is factory preset according to selected valve code, defaults are  $\pm 10$  Vdc for standard and  $4 \div 20$  mA for /I option.

Input signal can be reconfigured via software selecting between voltage and current, within a maximum range of  $\pm 10$  VDC or  $\pm 20$  mA.

Drivers with fieldbus interface can be software set to receive reference signal directly by the machine control unit (fieldbus reference).

Analog reference input signal can be used as on-off commands with input range  $0 \div 24$ VDC.

### 18.5 Flow monitor output signal (Q\_MONITOR)

The driver generates an analog output signal proportional to the actual spool position of the valve; the monitor output signal can be software set to show other signals available in the driver (e.g. analog reference, fieldbus reference, pilot spool position).

Monitor output signal is factory preset according to selected valve code, defaults are  $\pm 10$  Vdc for standard and  $4 \div 20$  mA for /I option.

Output signal can be reconfigured via software selecting between voltage and current, within a maximum range of  $\pm 10$  VDC or  $\pm 20$  mA.

### 18.6 Pressure or force monitor output signal (F\_MONITOR) - only for SP, SF, SL

The driver generates an analog output signal proportional to alternated pressure/force control; the monitor output signal can be software set to show other signals available in the driver (e.g. analog reference, force reference).

Monitor output signal is factory preset according to selected valve code, defaults are  $\pm 10$  VDC for standard and  $4 \div 20$  mA for /I option.

Output signal can be reconfigured via software selecting between voltage and current, within a maximum range of  $\pm 10$  VDC or  $\pm 20$  mA.

### 18.7 Enable input signal (ENABLE)

To enable the driver, supply a 24 VDC on pin 6: Enable input signal allows to enable/disable the current supply to the solenoid, without removing the electrical power supply to the driver; it is used to active the communication and the other driver functions when the valve must be disabled for safety reasons. This condition **does not comply** with norms IEC 61508 and ISO 13849.

Enable input signal can be used as generic digital input by software selection.

### 18.8 Fault output signal (FAULT)

Fault output signal indicates fault conditions of the driver (solenoid short circuits/not connected, reference signal cable broken for  $4 \div 20$  mA input, spool position transducer cable broken, etc.). Fault presence corresponds to 0 VDC, normal working corresponds to 24 VDC.

Fault status is not affected by the Enable input signal. Fault output signal can be used as digital output by software selection.

### 18.9 Remote pressure/force transducer input signal - only for SP, SF, SL

Analog remote pressure transducers or load cell can be directly connected to the driver.

Analog input signal is factory preset according to selected valve code, defaults are  $\pm 10$  VDC for standard and  $4 \div 20$  mA for /C option.

Input signal can be reconfigured via software selecting between voltage and current, within a maximum range of  $\pm 10$  VDC or  $\pm 20$  mA.

Refer to pressure/force transducer characteristics to select the transducer type according to specific application requirements (see table FX500).

## 19 TERMINAL BOARD OVERVIEW

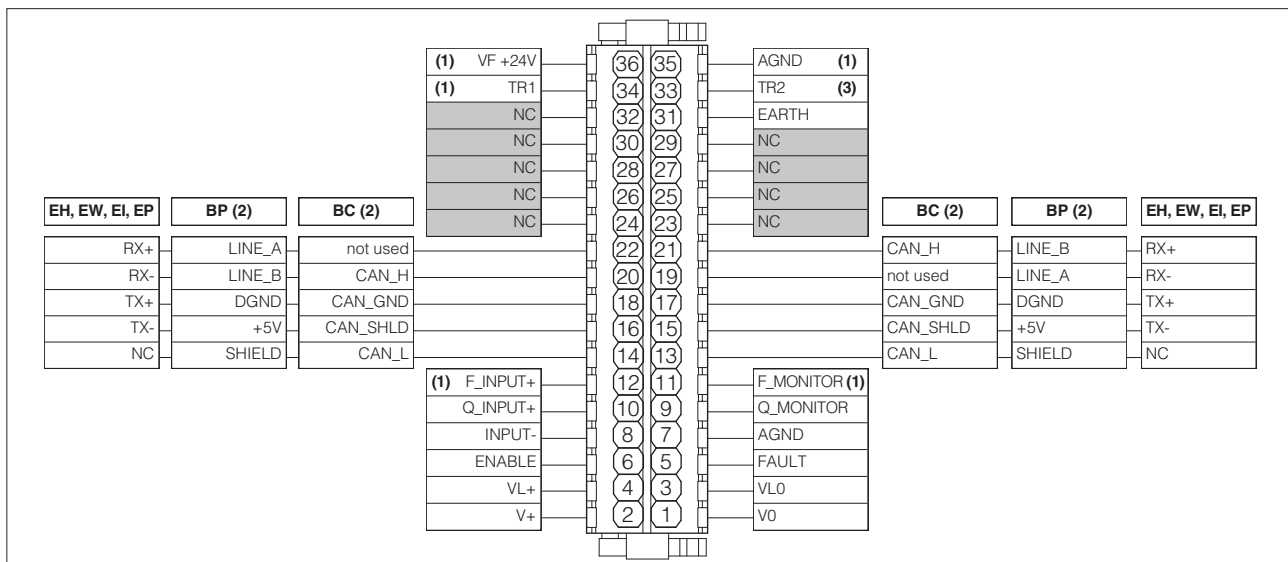

(1) connections available only **SP, SF, SL**

(2) For BC and BP executions the fieldbus connections have an internal pass-through connection

(3) connection available only **SF**

## 20 ELECTRONIC CONNECTIONS

### 20.1 Main connections signals

CABLE ENTRANCE	PIN	SIGNAL	TECHNICAL SPECIFICATIONS	NOTES
<b>A</b>	1	<b>V0</b>	Power supply 0 Vdc	Gnd - power supply
	2	<b>V+</b>	Power supply 24 Vdc	Input - power supply
	3	<b>VL0</b>	Power supply 0 Vdc for driver's logic and communication	Gnd - power supply
	4	<b>VL+</b>	Power supply 24 Vdc for driver's logic and communication	Input - power supply
	5	<b>FAULT</b>	Fault (0 Vdc) or normal working (24 Vdc), referred to VL0	Output - on/off signal
	6	<b>ENABLE</b>	Enable (24 Vdc) or disable (0 Vdc) the driver, referred to VL0	Input - on/off signal
	7	<b>AGND</b>	Analog ground	Gnd - analog signal
	8	<b>INPUT-</b>	Negative reference input signal for Q_INPUT+ and F_INPUT+	Input - analog signal
	9	<b>Q_MONITOR</b>	Flow monitor output signal: $\pm 10$ Vdc / $\pm 20$ mA maximum range, referred to AGND Defaults are: $\pm 10$ Vdc for standard and $4 \div 20$ mA for /I option	Output - analog signal <b>Software selectable</b>
	10	<b>Q_INPUT+</b>	Flow reference input signal: $\pm 10$ Vdc / $\pm 20$ mA maximum range Defaults are: $\pm 10$ Vdc for standard and $4 \div 20$ mA for /I option	Input - analog signal <b>Software selectable</b>
	11	<b>F_MONITOR</b>	Pressure/Force monitor output signal: $\pm 10$ Vdc / $\pm 20$ mA maximum range, referred to AGND (1) Defaults are: $\pm 10$ Vdc for standard and $4 \div 20$ mA for /I option	Output - analog signal <b>Software selectable</b>
	12	<b>F_INPUT+</b>	Pressure/Force reference input signal: $\pm 10$ Vdc / $\pm 20$ mA maximum range (1) Defaults are: $\pm 10$ Vdc for standard and $4 \div 20$ mA for /I option	Input - analog signal <b>Software selectable</b>
31	<b>EARTH</b>	Internally connected to driver housing		

(1) Available only for **SP, SF, SL**

### 20.2 USB connector - M12 - 5 pin always present

CABLE ENTRANCE	PIN	SIGNAL	TECHNICAL SPECIFICATIONS	Driver view	
<b>B</b>	1	<b>+5V_USB</b>	Power supply		
	2	<b>ID</b>	Identification		
	3	<b>GND_USB</b>	Signal zero data line		
	4	<b>D-</b>	Data line -		
	5	<b>D+</b>	Data line +		

### 20.3 BC fieldbus execution connections

CABLE ENTRANCE	PIN	SIGNAL	TECHNICAL SPECIFICATIONS
<b>C1</b>	14	<b>CAN_L</b>	Bus line (low)
	16	<b>CAN_SHLD</b>	Shield
	18	<b>CAN_GND</b>	Signal zero data line
	20	<b>CAN_H</b>	Bus line (high)
	22	<b>not used</b>	Pass-through connection (1)

CABLE ENTRANCE	PIN	SIGNAL	TECHNICAL SPECIFICATIONS
<b>C2</b>	13	<b>CAN_L</b>	Bus line (low)
	15	<b>CAN_SHLD</b>	Shield
	17	<b>CAN_GND</b>	Signal zero data line
	19	<b>not used</b>	Pass-through connection (1)
	21	<b>CAN_H</b>	Bus line (high)

(1) Pin 19 and 22 can be fed with external +5V supply of CAN interface

### 20.4 BP fieldbus execution connections

CABLE ENTRANCE	PIN	SIGNAL	TECHNICAL SPECIFICATIONS
<b>C1</b>	14	<b>SHIELD</b>	
	16	<b>+5V</b>	Power supply
	18	<b>DGND</b>	Data line and termination signal zero
	20	<b>LINE_B</b>	Bus line (low)
	22	<b>LINE_A</b>	Bus line (high)

CABLE ENTRANCE	PIN	SIGNAL	TECHNICAL SPECIFICATIONS
<b>C2</b>	13	<b>SHIELD</b>	
	15	<b>+5V</b>	Power supply
	17	<b>DGND</b>	Data line and termination signal zero
	19	<b>LINE_A</b>	Bus line (high)
	21	<b>LINE_B</b>	Bus line (low)

### 20.5 EH, EW, EI, EP fieldbus execution connections

CABLE ENTRANCE	PIN	SIGNAL	TECHNICAL SPECIFICATIONS
<b>C1</b> (input)	14	<b>NC</b>	do not connect
	16	<b>TX-</b>	Transmitter
	18	<b>TX+</b>	Transmitter
	20	<b>RX-</b>	Receiver
	22	<b>RX+</b>	Receiver

CABLE ENTRANCE	PIN	SIGNAL	TECHNICAL SPECIFICATIONS
<b>C2</b> (output)	13	<b>NC</b>	do not connect
	15	<b>TX-</b>	Transmitter
	17	<b>TX+</b>	Transmitter
	19	<b>RX-</b>	Receiver
	21	<b>RX+</b>	Receiver

### 20.6 Remote pressure transducer connector - only for **SP, SF, SL**

CABLE ENTRANCES	PIN	SIGNAL	TECHNICAL SPECIFICATIONS	NOTES	SP, SL - Single transducer (1)		SF - Double transducers (1)	
					Voltage	Current	Voltage	Current
<b>D1</b>	33	<b>TR2</b>	2nd signal transducer $\pm 10$ Vdc / $\pm 20$ mA maximum range	Input - analog signal <b>Software selectable</b>	/	/	Connect	Connect
	34	<b>TR1</b>	1st signal transducer $\pm 10$ Vdc / $\pm 20$ mA maximum range	Input - analog signal <b>Software selectable</b>	Connect	Connect	Connect	Connect
<b>D2</b>	35	<b>AGND</b>	Common gnd for transducer power and signals	Common gnd	Connect	/	Connect	/
	36	<b>VF +24V</b>	Power supply +24Vdc	Output - power supply	Connect	Connect	Connect	Connect

**E-ATRA remote pressure transducer connection** - see tech table GX800

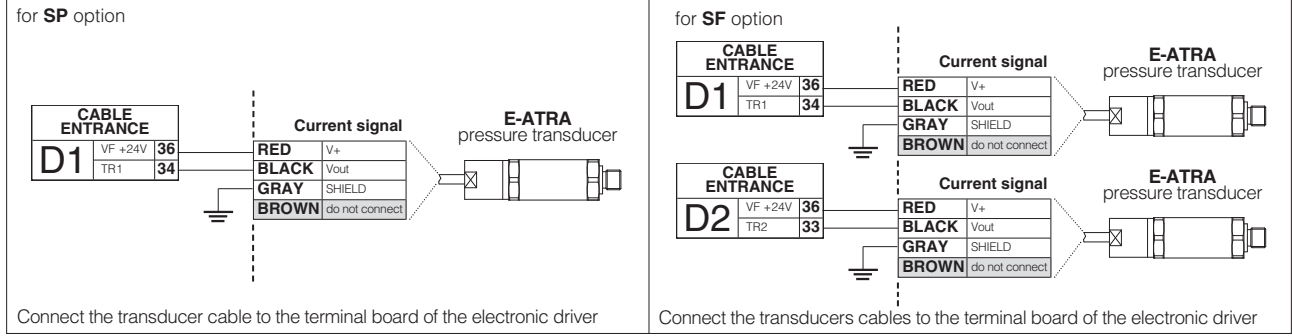

**21 CONNECTIONS LAYOUT**

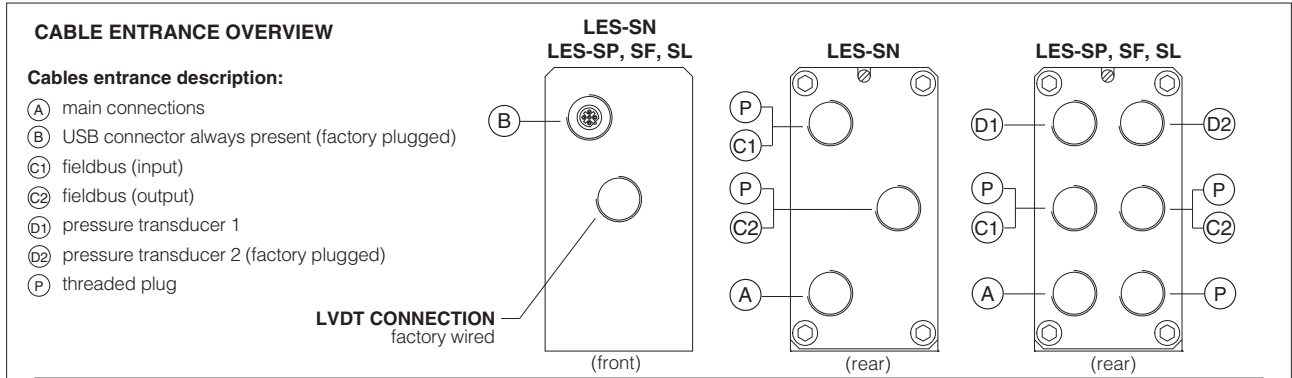

**TERMINAL BOARD AND FIELDBUS TERMINATOR**

Remove the 4 screws of driver's rear cover to access terminal board and fieldbus terminator

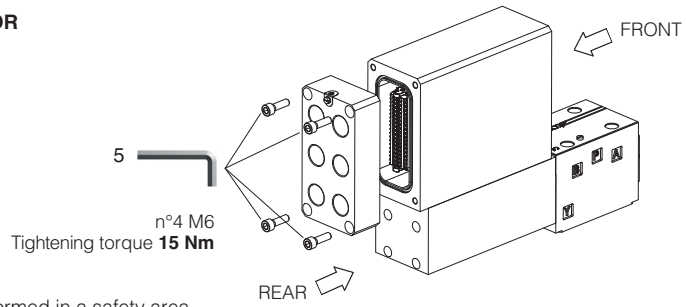

**WARNING:** the above operation must be performed in a safety area

Terminal board - see section 19

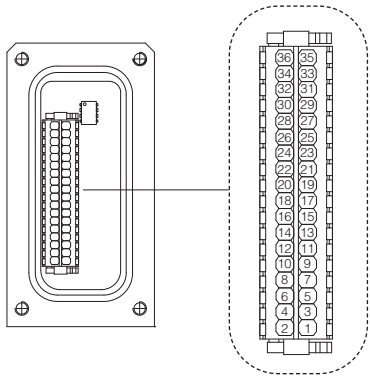

Fieldbus terminator only for BC and BP executions **(1)**

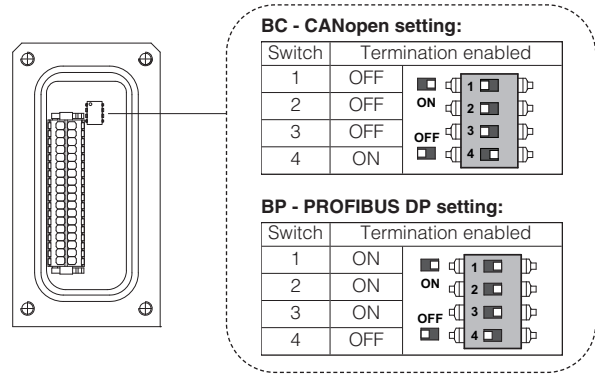

**BLUETOOTH ADAPTER AND USB CONNECTOR**

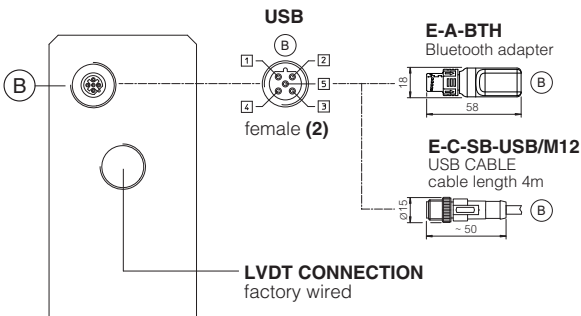

**METALLIC PROTECTION CAP** - supplied with the valves

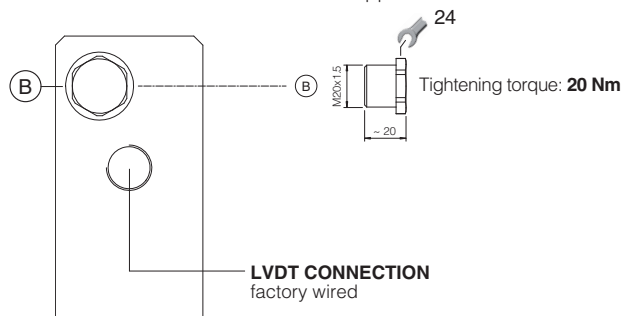

**(1)** Drivers with BC and BP fieldbus interface are delivered by default 'Not Terminated'. All switches are set OFF  
**(2)** Pin layout always referred to driver's view

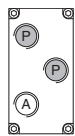
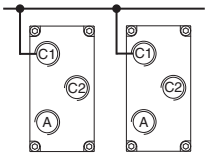
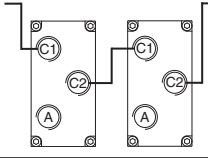

**21.1 Cable glands and threaded plug for LES-SN - see tech table KX800**

Communication interfaces	To be ordered separately				Cable entrance overview	Notes
	Cable gland quantity	entrance	Threaded plug quantity	entrance		
NP	1	A	none	none		Cable entrance A is open for costumers Cable entrance P are factory plugged
BC, BP, EH, EW, EI, EP "via stub" connection	2	C1 A	1	C2		Cable entrance A, C1, C2 are open for costumers
BC, BP, EH, EW, EI, EP "daisy chain" connection	3	C1 C2 A	none	none		Cable entrance A, C1, C2 are open for costumers

**21.2 Cable glands and threaded plug for LES-SP, SF, SL - see tech table KX800**

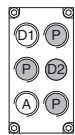
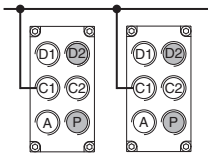
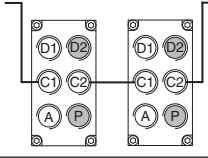
Communication interfaces	To be ordered separately				Cable entrance overview	Notes
	Cable gland quantity	entrance	Threaded plug quantity	entrance		
NP	2 (SP) 3 (SF) 2 (SL)	D1 D2 A	none	none		Cable entrance A, D1 are open for costumers Cable entrance P, D2 are factory plugged <b>(1)</b>
BC, BP, EH, EW, EI, EP "via stub" connection	3 (SP) 4 (SF) 3 (SL)	D1 - D2 C1 A	1	C2		Cable entrance A, C1, C2, D1 are open for costumers Cable entrance P, D2 are factory plugged <b>(1)</b>
BC, BP, EH, EW, EI, EP "daisy chain" connection	4 (SP) 5 (SF) 4 (SL)	D1 - D2 C1 - C2 A	none	none		Cable entrance A, C1, C2, D1 are open for costumers Cable entrance P, D2 are factory plugged <b>(1)</b>

**(1)** Remove plug D2 for second transducer connection of SF version

## 22 PLUGS LOCATION FOR PILOT/DRAIN CHANNELS

Depending on the position of internal plugs, different pilot/drain configurations can be obtained as shown below.  
To modify the pilot/drain configuration, proper plugs must only be interchanged. The plugs have to be sealed using loctite 270.  
Standard valves configuration provides internal pilot and external drain

DPZA-1	Pilot channels	Drain channels	<p><b>Internal piloting:</b> blinded plug SP-X300F ① in X;  <b>External piloting:</b> blinded plug SP-X300F ② in Pp;  <b>Internal drain:</b> blinded plug SP-X300F ③ in Y;  <b>External drain:</b> blinded plug SP-X300F ④ in Dr.</p>
DPZA-2	Pilot channels	Drain channels	<p><b>Internal piloting:</b> Without blinded plug SP-X300F ①;  <b>External piloting:</b> Add blinded plug SP-X300F ①;  <b>Internal drain:</b> Without blinded plug SP-X300F ②;  <b>External drain:</b> Add blinded plug SP-X300F ②.</p>
DPZA-4	Pilot channels	Drain channels	<p><b>Internal piloting:</b> Without blinded plug SP-X500F ①;  <b>External piloting:</b> Add blinded plug SP-X500F ①;  <b>Internal drain:</b> Without blinded plug SP-X300F ②;  <b>External drain:</b> Add blinded plug SP-X300F ②.</p>

## 23 FASTENING BOLTS AND SEALS

Type	Size	Fastening bolts	Seals
DPZA	1 = 10	4 socket head screws M6x40 class 12.9 Tightening torque = 15 Nm	5 OR 2050; Diameter of ports A, B, P, T: Ø 11 mm (max) 2 OR 108 Diameter of ports X, Y: Ø = 5 mm (max)
	2 = 16	4 socket head screws M10x50 class 12.9 Tightening torque = 70 Nm 2 socket head screws M6x45 class 12.9 Tightening torque = 15 Nm	4 OR 130; Diameter of ports A, B, P, T: Ø 20 mm (max) 2 OR 2043 Diameter of ports X, Y: Ø = 7 mm (max)
	4 = 25	6 socket head screws M12x60 class 12.9 Tightening torque = 125 Nm	4 OR 4112; Diameter of ports A, B, P, T: Ø 24 mm (max) 2 OR 3056 Diameter of ports X, Y: Ø = 7 mm (max)
	4M = 27	6 socket head screws M12x60 class 12.9 Tightening torque = 125 Nm	4 OR 3137; Diameter of ports A, B, P, T: Ø 32 mm (max) 2 OR 3056 Diameter of ports X, Y: Ø = 7 mm (max)

## DPZA-LES-\*-1

ISO 4401: 2005

Mounting surface: 4401-05-05-0-05  
(see table P005)

Mass [kg]	
DPZA-*-17*	13,7
Option /G	+0,9

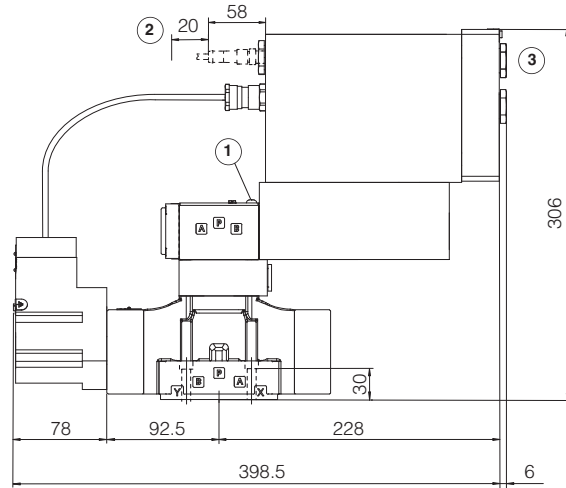
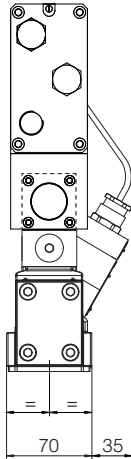

## DPZA-LES-\*-2

ISO 4401: 2005

Mounting surface: 4401-07-07-0-05  
(see table P005)

Mass [kg]	
DPZA-*-27*	17,9
Option /G	+0,9

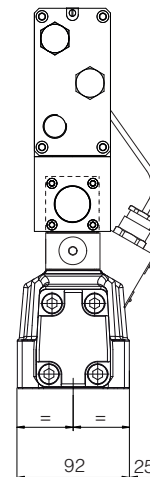
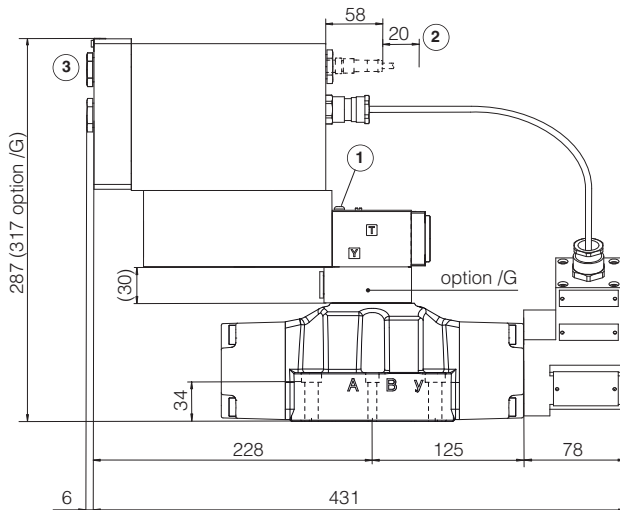

- ① = Air bleeding
- ② = Space required for connection cable and for Bluetooth adapter or USB connector removal
- ③ = The dimensions of cable glands must be considered (see tech table **KX800**)

# DPZA-LES-\*-4 DPZA-LES-\*-4M

ISO 4401: 2005

Mounting surface: 4401-08-08-0-05  
(see table P005)

Mass [kg]	
DPZA-*-4*	23,1
DPZA-*-4M*	23,1
Option /G	+0,9

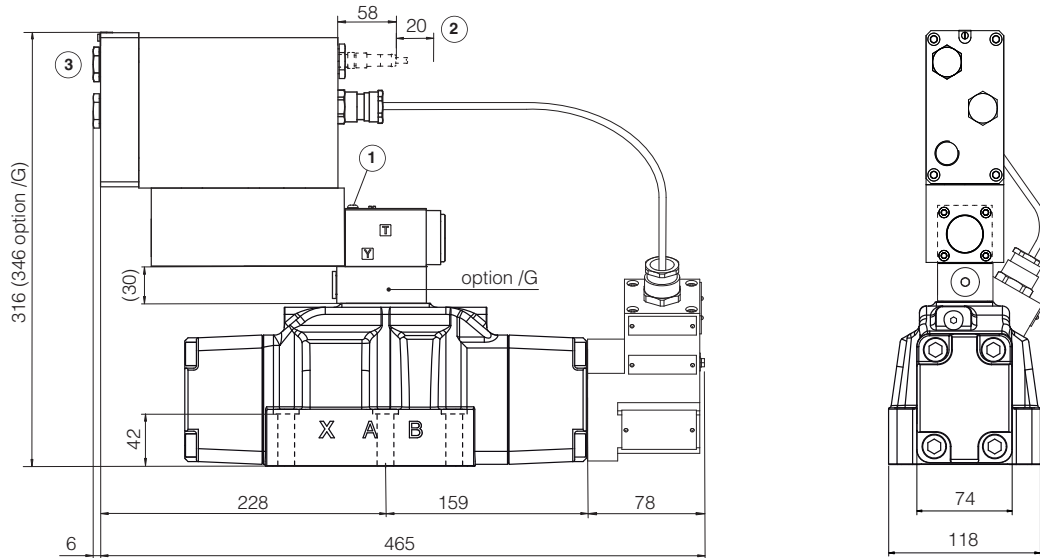

- ① = Air bleeding
- ② = Space required for connection cable and for Bluetooth adapter or USB connector removal
- ③ = The dimensions of cable glands must be considered (see tech table **KX800**)

## 25 RELATED DOCUMENTATION

**X010** Basics for electrohydraulics in hazardous environments  
**X020** Summary of Atos ex-proof components certified to ATEX, IECEx, EAC, PESO, CCC  
**FX500** Ex-proof digital proportionals with p/Q control  
**FX630** Ex-proof servoproportionals with on-board axis card  
**FX900** Operating and maintenance information for ex-proof proportional valves  
**GS500** Programming tools

**GS510** Fieldbus  
**GX800** Ex-proof pressure transducer type E-ATRA-7  
**KX800** Cable glands for ex-proof valves  
**P005** Mounting surfaces for electrohydraulic valves  
**E-MAN-RA-LES** TES/LES user manual  
**E-MAN-RA-LES-S** TES/LES with p/Q control user manual