

Ex-proof proportional pressure cartridges

without transducer - **ATEX, IECEx, EAC, PESO, CCC** or **cULus**

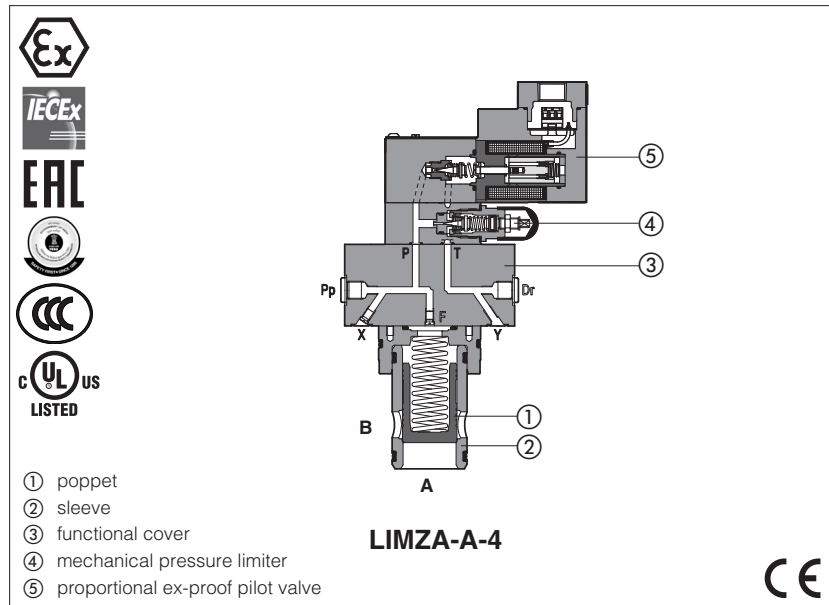

LICZA-A, LIMZA-A, LIRZA-A

2-way ex-proof proportional pressure cartridges without transducer respectively performing: pressure compensator, relief or reducing functions.

They are equipped with ex-proof proportional solenoids certified for safe operations in hazardous environments with potentially explosive atmosphere.

Certifications:

- Multicertification **ATEX, IECEx, EAC, PESO, CCC** for gas group **II 2G** and dust category **II 2D**
- Multicertification **ATEX, IECEx** for gas group **I M2** (mining)
- **cULus** North American certification for gas group **C&D**

The flameproof enclosure of solenoid prevents the propagation of accidental internal sparks or fire to the external environment.

The solenoid is also designed to limit the surface temperature within the classified limits.

Size: **16 ÷ 80** - ISO 7368

Max flow: up to **4500 l/min**

Max pressure: **250 bar**

1 MODEL CODE OF FUNCTIONAL COVERS

LIMZA	/	*	-	A	-	3	/	180	/	M	/	*	/	*	/	*	/	*
<p>Ex-proof proportional pressure cartridges valves:</p> <p>LICZA = pressure compensator LIMZA = pressure relief LIRZA = pressure reducing</p> <p>Certification type:</p> <p>Multicertification ATEX, IECEx, EAC, PESO, CCC: - = omit for Group II 2G / 2D (1) M = Group I M2 (mining)</p> <p>North American Certification: UL = cULus</p> <p>A = without transducer</p> <p>Valve size ISO 7368: 1 = size 16 2 = size 25 3 = size 32 4 = size 40 5 = size 50 (not for LIRZA) 6 = size 63 (only for LIMZA) 8 = size 80 (only for LIMZA)</p> <p>Max regulated pressure: 80 = 80 bar 180 = 180 bar 250 = 250 bar</p>																		
<p>Seals material, see section 9 :</p> <p>- = NBR PE = FKM BT = HNBR (2)</p> <p>Series number _____</p> <p>Voltage code: - = standard coil for 24 Vdc Atos drivers 24 = optional coil for 24 Vdc low current drivers</p> <p>Options (3): O = horizontal cable entrance (2) P =with integral mechanical pressure limiter (standard. for size 1, 2 and 3)</p> <p>Solenoid threaded connection for cable gland fitting: GK = GK-1/2" - not for cULus (4) M = M20x1,5 - not for cULus NPT = 1/2" NPT</p>																		

(1) The valves with Multicertification for Group II are also certified for Indian market according to **PESO** (Petroleum and Explosives Safety Organization). The PESO certificate can be downloaded from www.atos.com

(2) Not for multicertification **M** group I (mining) (3) Possible combined options: /OP (4) Approved only for Italian market

 The pressure at T port makes difficult the manual override operation that can be possible only if its value is lower than 50 bar

2 HYDRAULICS SYMBOLS

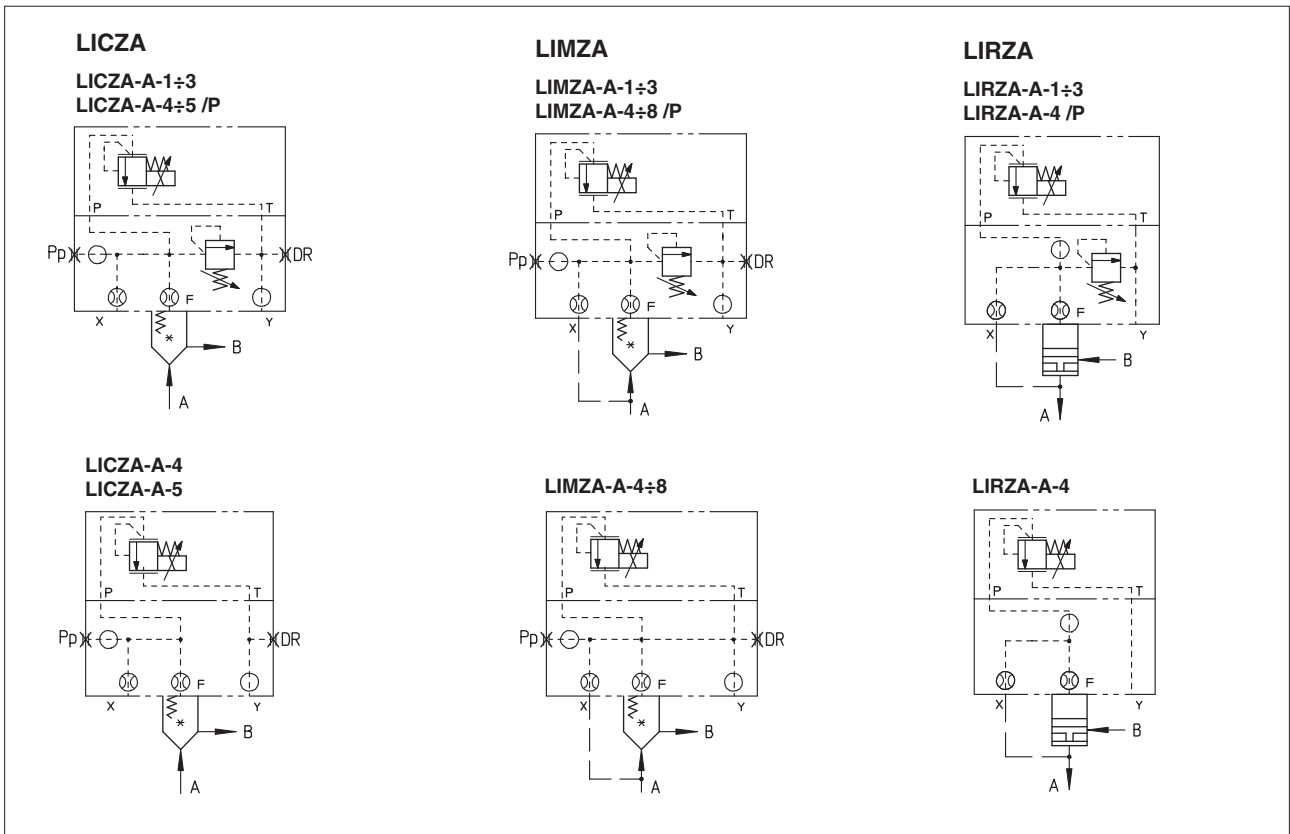

3 MODEL CODE OF CARTRIDGES

SC LI	-	32	31	2	**	/	*
Cartridge according to ISO 7368						<p>Seals material, see section 9 :</p> <p>- = NBR PE = FKM BT = HNBR</p>	
<p>Cartridges size ISO 7368:</p> <p>16 25 32 40 50 63 80</p>						<p>Series number</p>	
<p>Type of poppet:</p> <p>31 = for LIMZA and LICZA 36 = for LICZA 37 = for LIRZA</p>						<p>Spring cracking pressure:</p> <p>2 = 1,5 bar for poppet 31 3 = 3 bar for poppet 31 and 36 4 = 4 bar only for poppet 37 6 = 6 bar for poppet 31 and 36 7 = 7 bar for poppet 37 (only for size 16, 25, 32, 40)</p>	

4 TYPE OF POPPET

Type of poppet	31	36	37
Functional sketch (Hydraulic symbol)			
Typical section			
Area ratio A: Ap	1:1	1:1	1:1

5 ELECTRONIC DRIVERS

Electronic drivers are factory set with max current limitation for ex-proof valves.

Please include in the driver order also the complete code of the connected ex-proof proportional valve.

Drivers model	E-BM-AS-* /A	E-BM-AES-* /A
Type	digital	digital
Format	DIN-rail panel	
Data sheet	G030	GS050

6 GENERAL CHARACTERISTICS

Assembly position	Any position
Subplate surface finishing to ISO 4401	Acceptable roughness index, Ra ≤0,8 recommended Ra 0,4 - flatness ratio 0,01/100
MTTFd valves according to EN ISO 13849	150 years, see technical table P007
Ambient temperature range	Standard = -20°C ÷ +70°C /PE option = -20°C ÷ +70°C /BT option = -40°C ÷ +70°C
Storage temperature range	Standard = -20°C ÷ +80°C /PE option = -20°C ÷ +80°C /BT option = -40°C ÷ +70°C
Surface protection	Zinc coating with black passivation - salt spray test (EN ISO 9227) > 200h
Compliance	Explosion proof protection, see section 10 -Flame proof enclosure "Ex d" -Dust ignition protection by enclosure "Ex t" RoHs Directive 2011/65/EU as last update by 2015/863/EU REACH Regulation (EC) n°1907/2006

7 HYDRAULIC CHARACTERISTICS - based on mineral oil ISO VG 46 at 50 °C

Valve model	LICZA					LIMZA					LIRZA						
	1	2	3	4	5	1	2	3	4	5	6	8	1	2	3	4	
Valve size [l/min]																	
Max flow [bar]	200	400	750	1000	2000	200	400	750	1000	2000	3000	4500	160	300	550	800	
Min regulated pressure	see section 15																
Max regulated pres. at port A [bar]	80; 180; 250					80; 180; 250					80; 180; 250						
Max pressure [bar]	Ports: T, Y = 210 Ports: P, A, B, X = 315																
Response time 0-100% step signal (1) (depending on installation) [ms]	≤ 120 ÷ 430					≤ 120 ÷ 480					≤ 120 ÷ 380						
Hysteresis [% of regulated max pres.]	≤ 2					≤ 1,5					≤ 2						
Linearity [% of regulated max pres.]	≤ 3					≤ 3					≤ 3						
Repeatability [% of regulated max pres.]	≤ 2					≤ 2					≤ 2						

Note: above performance data refer to valves coupled with Atos electronic drivers, see section 5

(1) Average response time value; the pressure variation in consequence of a modification of the reference input signal to the valve is affected by the stiffness of the hydraulic circuit: greater is the stiffness of the circuit, faster is the dynamic response

8 ELECTRICAL CHARACTERISTICS

Max. power	35W	
Insulation class	H (180°) Due to the occurring surface temperatures of the solenoid coils, the European standards ISO 13732-1 and EN982 must be taken into account	
Protection degree with relevant cable gland	Multicertification: IP66/67 to DIN EN60529 UL: raintight enclosure, UL approved	
Duty factor	Continuous rating (ED=100%)	
Voltage code	standard	option /24
Coil resistance R at 20°C	3,2 Ω	17,6 Ω
Max. solenoid current	2,5 A	1,1 A

9 SEALS AND HYDRAULIC FLUIDS - for other fluids not included in below table, consult our technical office

Seals, recommended fluid temperature	NBR seals (standard) = -20°C ÷ +60°C, with HFC hydraulic fluids = -20°C ÷ +50°C FKM seals (/PE option) = -20°C ÷ +80°C HNBR seals (/BT option) = -40°C ÷ +60°C, with HFC hydraulic fluids = -40°C ÷ +50°C		
Recommended viscosity	20 ÷ 100 mm ² /s - max allowed range 15 ÷ 380 mm ² /s		
Max fluid contamination level	normal operation	ISO4406 class 18/16/13 NAS1638 class 7	see also filter section at www.atos.com or KTF catalog
	longer life	ISO4406 class 16/14/11 NAS1638 class 5	
Hydraulic fluid	Suitable seals type	Classification	Ref. Standard
Mineral oils	NBR, FKM, HNBR	HL, HLP, HLPD, HVLP, HVLDP	DIN 51524
Flame resistant without water	FKM	HF DU, HF DR	ISO 12922
Flame resistant with water (1)	NBR, HNBR	HFC	

⚠ The ignition temperature of the hydraulic fluid must be 50°C higher than the max solenoid surface temperature

(1) **Performance limitations in case of flame resistant fluids with water:**

- max operating pressure = 210 bar
- max fluid temperature = 50°C

10 CERTIFICATION DATA

Valve type	LI*ZA		LI*ZA/M	LI*ZA/UL	
Certifications	Multicertification Group II ATEX, IECEx, EAC, PESO, CCC		Multicertification Group I ATEX, IECEx	North American cULus	
Solenoid certified code	OZA-A		OZAM-A	OZA-A/EC	
Type examination certificate (1)	ATEX: CESI 02 ATEX 014 IECEX: IECEX CES 10.0010x EAC: RU C - IT.AX38.B.00425/21 PESO: P468212/2 CCC: 2020322307003240		ATEX: CESI 03 ATEX 057x IECEX: IECEX CES 12.0007x	20170324 - E366100	
Method of protection	<ul style="list-style-type: none"> • ATEX, EAC Ex II 2G Ex db IIC T4/T3 Gb Ex II 2D Ex tb IIIC T135°C/T200°C Db • IECEX Ex db IIC T4/T3 Gb Ex tb IIIC T135°C/T200°C Db • PESO Ex db IIC T4/T3 Gb • EAC 1Ex d IIC T4/T3 Gb X Ex tb IIIC T135°C/T200°C Db X • CCC Ex d IIC T4/T3 Gb Ex tD A21 IP66/IP67 T135°C/T200°C 		<ul style="list-style-type: none"> • ATEX Ex I M2 Ex db I Mb • IECEX Ex db I Mb 	<ul style="list-style-type: none"> • UL 1203 Class I, Div.I, Groups C & D Class I, Zone I, Groups IIA & IIB 	
Temperature class	T4	T3	-	T4	T3
Surface temperature	≤ 135 °C	≤ 200 °C	≤ 150 °C	≤ 135 °C	≤ 200 °C
Ambient temperature (2)	-40 ÷ +40 °C	-40 ÷ +70 °C	-20 ÷ +60 °C	-40 ÷ +55 °C	-40 ÷ +70 °C
Applicable standards	EN 60079-0 EN 60079-1 EN 60079-31		IEC 60079-0 IEC 60079-1 IEC 60079-31	UL 1203 and UL429, CSA 22.2 n°30-1986 CSA 22.2 n°139-13	
Cable entrance: threaded connection vertical (standard) or horizontal (option /O)	GK = GK-1/2" M = M20x1,5		NPT = 1/2" NPT	1/2" NPT	

(1) The type examination certificates can be downloaded from www.atos.com

(2) The solenoids **Group II** and **cULus** are certified for minimum ambient temperature -40°C

In case the complete valve must withstand with minimum ambient temperature of -40°C, select **/BT** in the model code

⚠ WARNING: service work performed on the valve by the end users or not qualified personnel invalidates the certification

11 EX PROOF SOLENOIDS WIRING OF VALVES -A without integral driver

Multicertification

Standard version **Option /O**

① cover with threaded connection for vertical cable gland fitting
② cover with threaded connection for horizontal cable gland fitting
③ terminal board for cables wiring
④ screw terminal for additional equipotential grounding

cULus certification

Standard version **Option /O**

① cover with threaded connection for vertical cable gland fitting
② cover with threaded connection for horizontal cable gland fitting
③ terminal board for cables wiring

⚠ Pay attention to respect the polarity

12 CABLE SPECIFICATION AND TEMPERATURE - Power supply and grounding cables have to comply with following characteristics:

Multicertification Group I and Group II	
Power supply: section of coil connection wires = 2,5 mm ²	Grounding: section of internal ground wire = 2,5 mm ² section of external ground wire = 4 mm ²
cULus certification:	
<ul style="list-style-type: none"> • Suitable for use in Class I Division 1, Gas Groups C • Armored Marine Shipboard Cable which meets UL 1309 • Tinned Stranded Copper Conductors • Bronze braided armor • Overall impervious sheath over the armor 	
Any Listed (UBVZ/UBVZ7) Marine Shipboard Cable rated 300 V min, 15A min. 3C 2,5 mm ² (14 AWG) having a suitable service temperature range of at least -25°C to +110°C ("BT" Models require a temperature range from -40°C to +110°C)	
Note 1: For Class I wiring the 3C 1,5 mm ² AWG 16 cable size is admitted only if a fuse lower than 10 A is connected to the load side of the solenoid wiring.	

12.1 Cable temperature

The cable must be suitable for the working temperature as specified in the "safety instructions" delivered with the first supply of the products.

Multicertification

Max ambient temperature [°C]	Temperature class		Max surface temperature [°C]		Min. cable temperature [°C]	
	Goup I	Goup II	Goup I	Goup II	Goup I	Goup II
40 °C	-	T4	150 °C	135 °C	90 °C	90 °C
45 °C	-	T4	-	135 °C	-	95 °C
55 °C	-	T3	-	200 °C	-	110 °C
60 °C	-	-	150 °C	-	110 °C	-
70 °C	N.A.	T3	N.A.	200 °C	N.A.	120 °C

cULus certification

Max ambient temperature [°C]	Temperature class	Max surface temperature [°C]	Min. cable temperature
55 °C	T4	135 °C	100 °C
70 °C	T3	200 °C	100 °C

13 CABLE GLANDS - only **Multicertification**

Cable glands with threaded connections GK-1/2", 1/2"NPT or M20x1,5 for standard or armoured cables have to be ordered separately, see tech. table **KX800**

Note: a Loctite sealant type 545, should be used on the cable gland entry threads

14 OPTIONS

O = Horizontal cable entrance, to be selected in case of limited vertical space.

P = Integral mechanical pressure limiter (standard for size 1, 2 and 3)

The LICZA-A*, LIMZA-A* and LIRZA-A* standard size 1, 2, 3 and option /P are provided with mechanical pressure limiter acting as protection against overpressure. For safety reasons the factory setting of the mechanical pressure limiter is fully unloaded (min pressure).

At the first commissioning it must be set at a value lightly higher than the max pressure regulated with the proportional control.

For the pressure setting of the mechanical pressure limiter, proceed according to following steps:

- apply the max reference input signal to the valve's driver. The system pressure will not increase until the mechanical pressure limiter remains unloaded.
- turn clockwise the adjustment screw ① until the system pressure will increase up to a stable value corresponding to the pressure setpoint at max reference input signal.
- turn clockwise the adjustment screw ① of additional 1 or 2 turns to ensure that the mechanical pressure limiter remains closed during the proportional valve working.

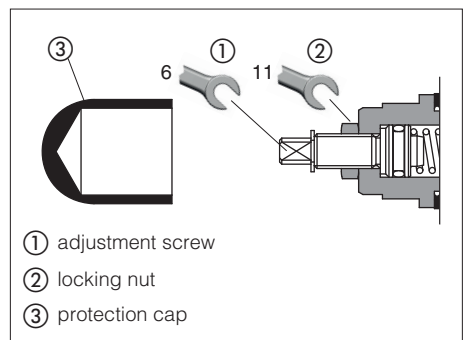

14.1 Possible combined options: /OP

15 **DIAGRAMS** (based on mineral oil ISO VG 46 at 50 °C)

- 1** Regulation diagrams LIMZA
- 2** Regulation diagrams LICZA

- 3** Pressure/flow diagrams LICZA, LIMZA

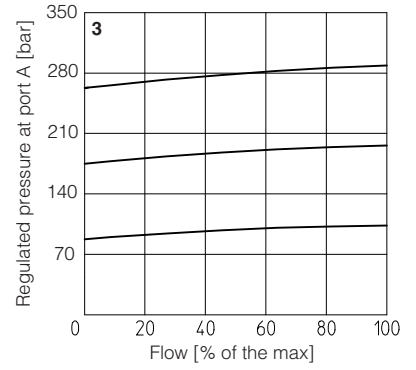
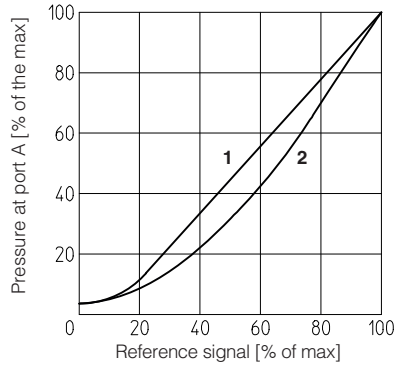

4-14 **Min. pressure/flow diagrams**
with zero reference signal

- 4** = LIMZA-^{*}-1 **11** = LICZA-^{*}-1
- 5** = LIMZA-^{*}-2 **12** = LICZA-^{*}-2
- 6** = LIMZA-^{*}-3 **13** = LICZA-^{*}-3
- 7** = LIMZA-^{*}-4 **14** = LICZA-^{*}-4
- 8** = LIMZA-^{*}-5 **15** = LICZA-^{*}-5
- 9** = LIMZA-^{*}-6
- 10** = LIMZA-^{*}-8

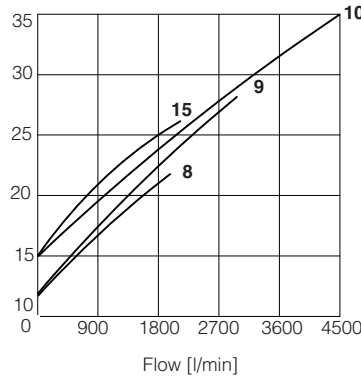
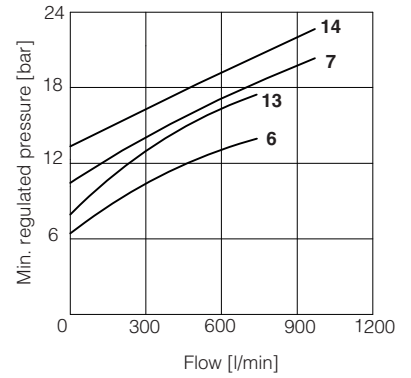
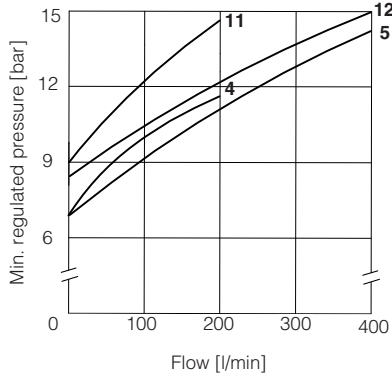

Regulation diagrams LIRZA

- 15** = LIRZA-A

16-19 **Min. pressure/flow diagrams**
with reference signal "null"

- 16** = LIRZA-^{*}-1
- 17** = LIRZA-^{*}-2
- 18** = LIRZA-^{*}-3
- 19** = LIRZA-^{*}-4

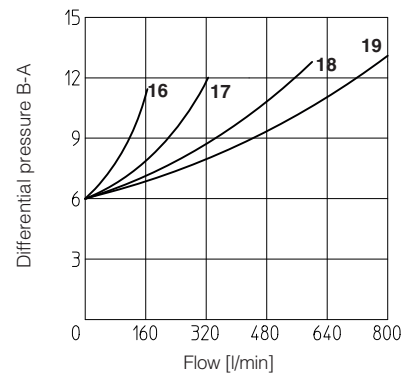
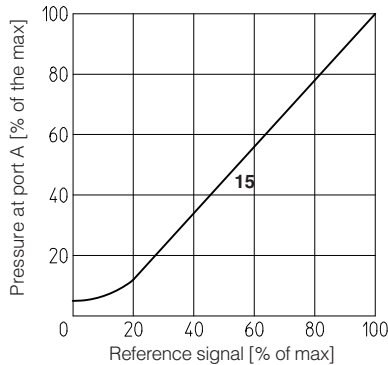

Pressure/flow diagrams

- 20** = LIRZA-A

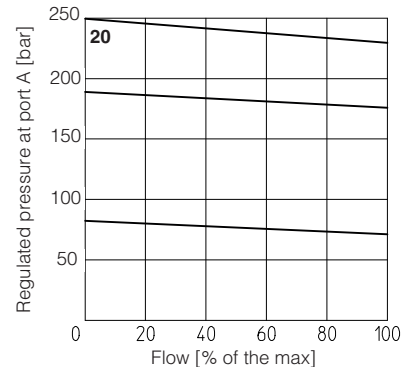

16 FASTENING BOLTS AND SEALS

Type	Size	Fastening bolts	Seals
LIMZA LICZA LIRZA	1 = 16	4 socket head screws M8x45 class 12.9 Tightening torque = 35 Nm	2 OR 108
	2 = 25	4 socket head screws M12x45 class 12.9 Tightening torque = 125 Nm	2 OR 108
	3 = 32	4 socket head screws M16x55 class 12.9 Tightening torque = 300 Nm	2 OR 2043
	4 = 40	4 socket head screws M20x70 class 12.9 Tightening torque = 600 Nm	2 OR 3043
LIMZA LICZA	5 = 50	4 socket head screws M20x80 class 12.9 Tightening torque = 600 Nm	2 OR 3043
LIMZA	6 = 63	4 socket head screws M30x90 class 12.9 Tightening torque = 2100 Nm	2 OR 3050
	8 = 80	8 socket head screws M24x90 class 12.9 Tightening torque = 1000 Nm	2 OR 4075

17 COVERS DIMENSIONS [mm]

Size	AxA	ØB	C	D	Port Pp - Dr
1 = 16	65x80	3	4	40	-
2 = 25	85x85	5	6	40	-
3 = 32	100x100	5	6	50	-
4 = 40	125x125	5	6	60	G 1/4"
5 = 50	140x140	6	4	70	G 1/4"
6 = 63	180x180	6	4	80	G 3/8"
8 = 80	Ø250	8	6	80	G 3/8"

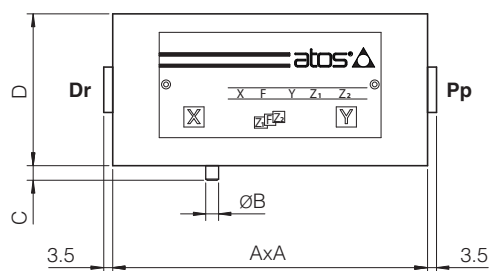

Notes:
 size 1 cover is not squared but rectangular, dimensions 65x80
 size 8 cover is not squared but circular, dimension Ø250

18 COVERS INSTALLATION DIMENSIONS [mm]

LICZA-A-1 LIMZA-A-1 LIRZA-A-1
 LICZA-A-2 LIMZA-A-2 LIRZA-A-2
 LICZA-A-3 LIMZA-A-3 LIRZA-A-3

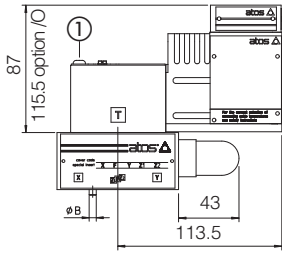

Mass [kg]			
Size	LICZA, LIMZA, LIRZA		Cartridge
	Standard	Option /P	SC LI
1	4,1	standard	0,2
2	4,8	standard	0,5
3	6,1	standard	0,9
4	11,5	12,5	1,7
5	15	16	2,9
6	24,5	25,5	6,7
8	33,1	34,1	13,1

① = Screw for air bleeding: at the first valve commissioning the air eventually trapped inside the solenoid must be bled-off though the screw ①

LICZA-A-4 LIMZA-A-4 LIRZA-A-4
 LICZA-A-5 LIMZA-A-5 LIMZA-A-6

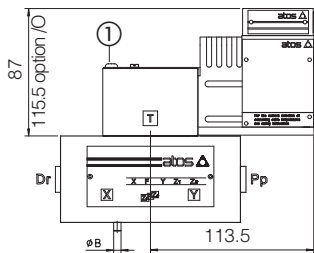

LICZA-A-4/P LIMZA-A-4/P LIRZA-A-4/P
 LICZA-A-5/P LIMZA-A-5/P LIMZA-A-6/P

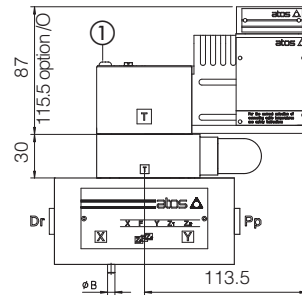

LIMZA-A-8

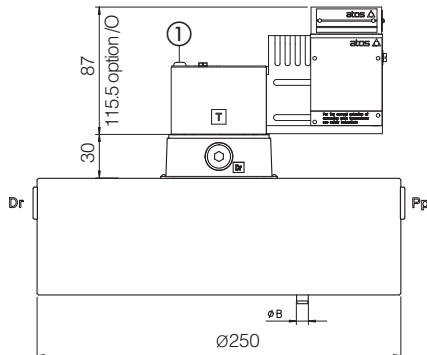

LIMZA-A-8/P

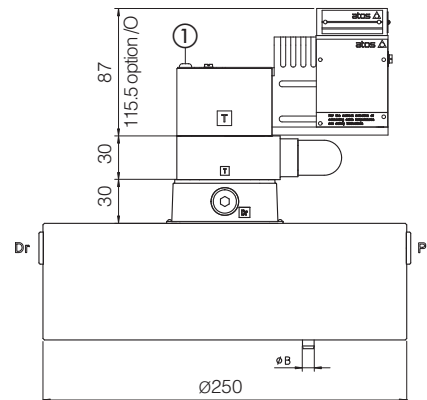

Note: for mounting surface and cavity dimensions, see tech. table P006

19 RELATED DOCUMENTATION

- X010 Basics for electrohydraulics in hazardous environments
- X020 Summary of Atos ex-proof components certified to ATEX, IECEX, EAC, CCC, PESO
- X030 Summary of Atos ex-proof components certified to cULus
- FX900 Operating and maintenance information for ex-proof proportional valves
- KX800 Cable glands for ex-proof valves
- P006 Mounting surfaces and cavities for cartridge valves