

Ex-proof digital servoproportionals with on-board axis card

direct, sleeve execution, with LVDT transducer and zero spool overlap - **ATEX and IECEx**

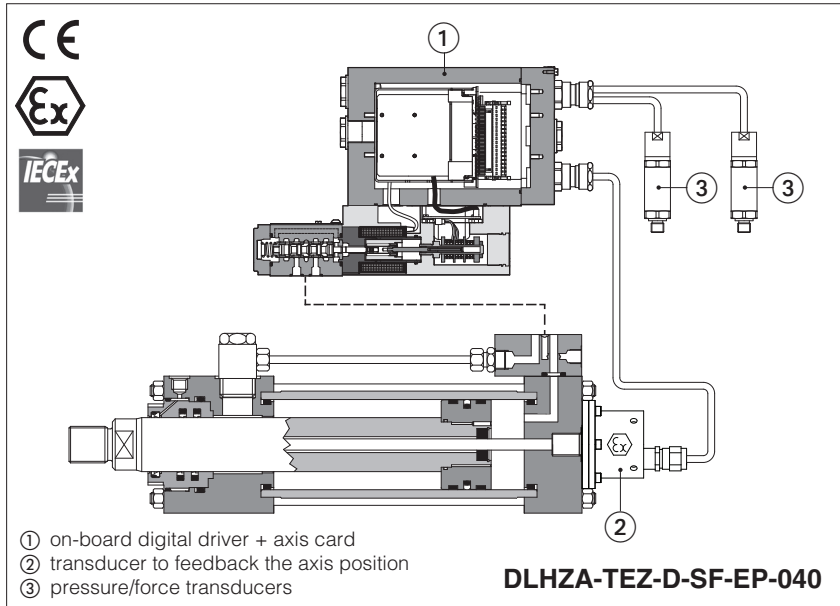

DLHZA-TEZ, DLKZA-TEZ

Ex-proof digital servoproportional valves equipped with on-board driver plus axis card, LVDT position transducer and zero spool overlap to perform the position control of any linear or rotative hydraulic actuator.

They are certified for safe operations in hazardous environments with potentially explosive atmosphere.

- Multicertification **ATEX** and **IECEx** for gas group **II 2G** and dust category **II 2D**

The controlled actuator has to be equipped with integral or external ex-proof transducer (analog, potentiometer, SSI or Encoder) to feedback the axis position.

The valve can be operated by an external or internally generated reference position signal, see section [2].

Options SF, SL add the alternated pressure/force control to the basic position one, see section [3].

DLHZA:	DLKZA:
Size: 06 -ISO 4401	Size: 10 -ISO 4401
Max flow: 50 l/min	Max flow: 100 l/min
Max pressure: 350 bar	Max pressure: 315 bar

1 MODEL CODE

DLHZA	-	TEZ	-	D	-	SN	-	NP	-	0	-	40	-	L	-	7	-	3	/	M	/	*	/	*	/	*	
<p>Ex-proof servoproportional directional valves, direct DLHZA = size 06 DLKZA = size 10</p> <p>TEZ = on-board digital driver + axis card, one LVDT transducer</p> <p>Position transducer type: A = Analog (standard, potentiometer) D = Digital (SSI, Encoder)</p> <p>Alternated P/Q controls: SN = none SF = force control (2 pressure transducers) SL = force control (1 load cell)</p> <p>Fieldbus interface, USB port always present: NP = Not Present BC = CANopen EW = POWERLINK BP = PROFIBUS DP EI = EtherNet/IP EH = EtherCAT EP = PROFINET RT/IRT</p> <p>Valve size ISO 4401: 0 = 06 1 = 10</p>																											
<p>Configuration: Standard</p> <p>40 = </p> <p>with fail safe configuration 1 or 3</p> <p>Option /B</p> <p>60 = </p> <p>without fail safe</p>																											
<p>Spool type, regulating characteristics:</p> <p>L = linear V = progressive T = not linear (1)</p> <p>D = differential-linear (1) DT = differential-not linear (1)</p> <p>P-A = Q, B-T = Q/2 P-A = Q, B-T = Q/2 P-B = Q/2, A-T = Q P-B = Q/2, A-T = Q</p>																											

Seals material,
see section [10]:

- = NBR
- PE** = FKM
- BT** = HNBR

Series number

Hydraulic options (2):

B = solenoid with integral electronics and position transducer at side of port A (**3**)
Y = external drain

Electronic options (2):

C = current feedback for pressure transducer
4 ÷ 20 mA, only for **SF, SL**
(omit for std voltage ±10 Vdc)
I = current reference input and monitor
4 ÷ 20 mA (omit for std voltage ±10 Vdc)

Cable entrance threaded connection:

M = M20x1,5

Fail safe configuration, see section [18]:



Note: select 1 for configuration 60 even without fail safe

Spool size: 0(L) 1(L) 1(V) 3(L) 3(T) 3(V) 5(L,T) 7(L,T,V,D,DT)

DLHZA =	4	7	8	14	-	20	28	40
DLKZA =	-	-	-	60	60	-	-	100

Nominal flow (l/min) at Δp 70bar P-T

(1) Only for configuration 40 (2) For possible combined options, see section [16]
(3) In standard configuration the solenoid with on-board digital driver and position transducer are at side port B

2 POSITION REFERENCE MODE

2.1 External reference generation

Axis controller regulates in closed loop the actuator position according to an external reference position signal and to the position feedback from the actuator transducer.

The external reference signal can be software selected among:

Analog reference (a) - the controller receives in real time the reference signal from the machine electronic central unit by means analog input on the terminal board.

Fieldbus reference (b) - the controller receives in real time the reference signal from the machine electronic central unit by means digital fieldbus communication.

For fieldbus communication details, please refer to the controller user manual.

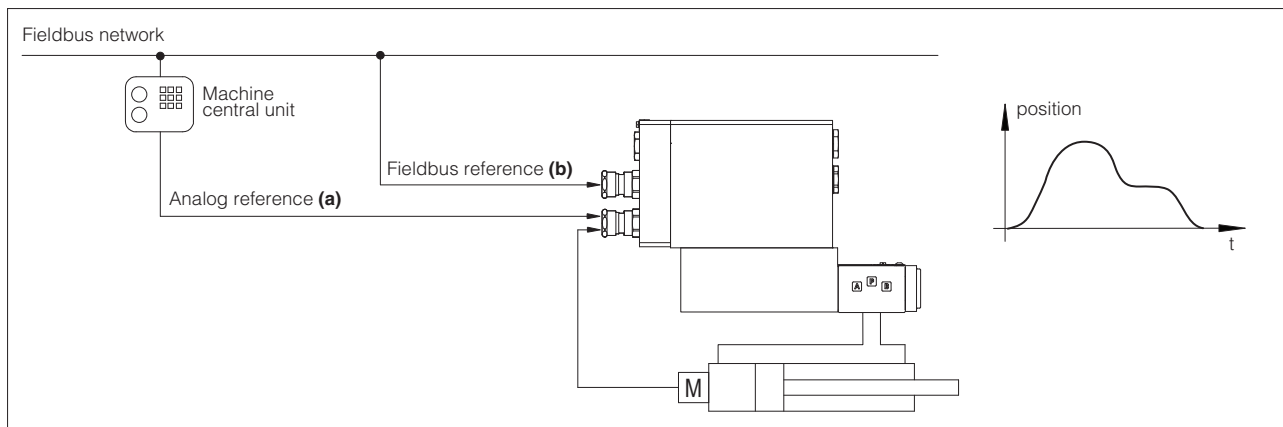

2.2 Internal reference generation

Axis controller regulates in closed loop the actuator position according to an internally generated reference position signal and to the position feedback from the actuator transducer.

The internal reference signal is generated by a pre-programmed cycle; only start, stop and switch-over commands are required from the machine electronic central unit by means :

- on-off commands (c)

- fieldbus commands (d)

Atos PC software allows to design a customized sequence of motion phases adapted to the specific application requirements: a range of predefined standard sequences are available in the Z-SW software.

Start/stop/switch-over commands and reference generation type can be set for each phase in order to realize an automatic cycle according to the application requests. Refer to the controller user manual for further details on commands and reference generation type.

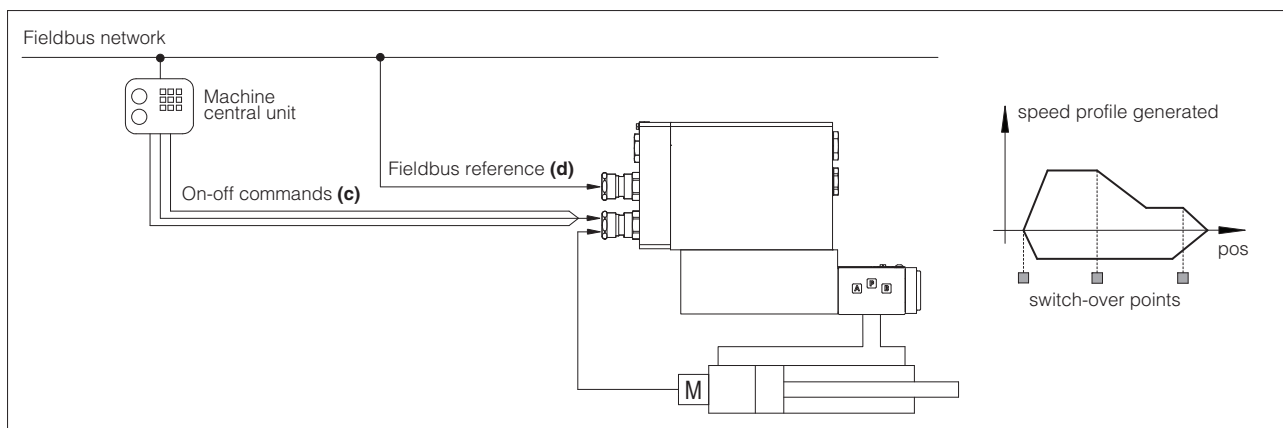

Start / stop / switch-over commands examples

External digital input on-off commands, on terminal board, are used to start/stop the cycle generation or to change the motion phase

External fieldbus input on-off commands, by fieldbus communication, are used to start/stop the cycle generation or to change the motion phase

Switch by position switch-over from actual to following motion phase occurs when the actual position reaches a programmed value

Switch by time switch-over from actual to following motion phase occurs after a fixed time, starting from the actual phase activation

Reference generation types examples

Absolute a target position reference signal is internally generated for each motion phase; maximum speed and acceleration can be set to obtain a smooth and precise position control

Relative as 'Absolute' but the target position corresponds to the actuator position plus a fixed quote internally set by software

Time as 'Absolute' type but the controller automatically determines the speed and acceleration in order to reach the target absolute position in the fixed time internally set by software

3 ALTERNATED POSITION / FORCE CONTROL

SF and **SL** options add the alternated force closed loop control to the actuator standard position control. Pressure or force remote transducers have to be installed on the actuator and interfaced to the valve driver, see below functional schemes.

The position/force controls are operated according to two separate reference signals and a dedicated algorithm automatically selects which control is active time by time.

The dynamics of the switching between the two controls can be regulated thanks to specific software setting, in order to avoid instability and vibrations.

Position control is active (see phase ① and ③ at side) when the actuator force is lower than the relevant reference signal - the valve controls the actuator position by closed-loop regulation.

Force control is active (see phase ② and ④ at side) when the actuator actual force, measured by remote transducers, grows up to the relevant reference signal - the controller reduces the valve's regulation in order to limit the actuator force; if the force tends to decrease under its reference signal, the position control returns active.

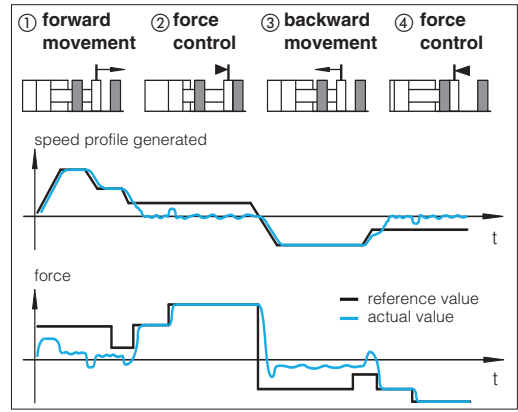

Alternated control configurations

SF	SL
<p>two remote pressure transducers have to be installed on the actuator's ports; the actuator force is calculated by the pressure feedbacks ($P_a - P_b$)</p>	<p>one load cell transducer has to be installed between the actuator and the controlled load</p>

T valve spool transducer	M actuator position transducer	P pressure transducer	L load cell
---------------------------------	---------------------------------------	------------------------------	--------------------

SF – position/force control

Adds force control to standard position control and permits to limit the max force in two directions controlling in closed loop the delta pressure acting on both sides of the hydraulic actuator. Two pressure transducers have to be installed on A and B hydraulic lines.

SL – position/force control

Adds force control to standard position control and permits to limit the max force in one or two directions controlling in closed loop the force performed by the hydraulic actuator. A load cell has to be installed on the hydraulic actuator.

General Notes:

- auxiliary check valves are recommended in case of specific hydraulic configuration requirements in absence of power supply or fault
- Atos technical office is available for additional evaluations related to specific applications

4 GENERAL NOTES

Atos digital proportionals valves are CE marked according to the applicable directives (e.g. Immunity and Emission EMC Directive). Installation, wirings and start-up procedures must be performed according to the general prescriptions shown in tech table **FX900** and in the user manuals included in the Z-SW-* programming software.

5 VALVE SETTINGS AND PROGRAMMING TOOLS

Valve's functional parameters and configurations, can be easily set and optimized using Atos Z-SW programming software connected via USB port to the digital controller (see table **GS003**). For fieldbus versions, the software permits valve's parameterization through USB port also if the controller is connected to the central machine unit via fieldbus.

Z-SW-FULL support: NP (USB)
 BC (CANopen) BP (PROFIBUS DP) EH (EtherCAT)
 EW (POWERLINK) EI (EtherNet/IP) EP (PROFINET)

Note: Z-SW programming software supports valves with option SF, SL for alternated control

WARNING: drivers **USB port is not isolated!** For E-C-SB-USB/M12 cable, the use of isolator adapter is highly recommended for PC protection (see tech table **GS500**)

WARNING: see tech table **GS500** for the list of countries where the Bluetooth adapter has been approved

USB or Bluetooth connection

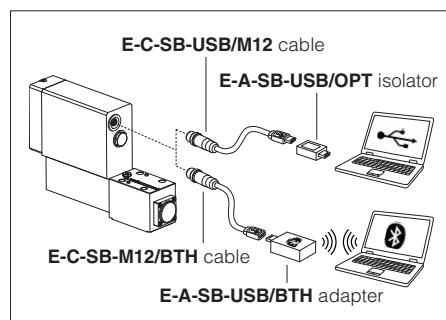

6 FIELDBUS - see tech. table **GS510**

Fieldbus allows valve direct communication with machine control unit for digital reference, valve diagnostics and settings. These executions allow to operate the valves through fieldbus or analog signals available on the terminal board.

7 GENERAL CHARACTERISTICS

Assembly position	Any position
Subplate surface finishing to ISO 4401	Acceptable roughness index, Ra ≤0,8 recommended Ra 0,4 - flatness ratio 0,01/100
MTTFd valves according to EN ISO 13849	150 years, see technical table P007
Ambient temperature range	Standard = -20°C ÷ +60°C /PE option = -20°C ÷ +60°C /BT option = -40°C ÷ +60°C
Storage temperature range	Standard = -20°C ÷ +70°C /PE option = -20°C ÷ +70°C /BT option = -40°C ÷ +70°C
Surface protection	Zinc coating with black passivation - salt spray test (ISO 9227) > 200 h
Compliance	Explosion proof protection, see section 11 -Flame proof enclosure "Ex d" -Dust ignition protection by enclosure "Ex t" RoHs Directive 2011/65/EU as last update by 2015/65/EU REACH Regulation (EC) n°1907/2006

8 HYDRAULIC CHARACTERISTICS - based on mineral oil ISO VG 46 at 50 °C

Valve model	DLHZA										DLKZA								
	ports P, A, B = 350; T = 210 (250 with external drain /Y)										ports P, A, B = 315; T = 210 (250 with external drain /Y)								
Pressure limits [bar]	L0	L1	V1	L3	V3	L5	T5	L7	T7	V7	D7	DT7	L3	T3	L7	T7	V7	D7	DT7
Max flow [l/min]																			
at Δp = 30 bar	2,5	4,5	8	9	13	18		26			26÷13		40		60			60÷33	
at Δp = 70 bar	4	7	12	14	20	28		40			40÷20		60		100			100÷50	
max permissible flow	5	9	16	18	26	32		50			50÷28		70		100			100÷50	
Δp max P-T [bar]	120	120	120	120	120	100		100			100		90		70			70	
Leakage [cm³/min] at P = 100 bar (1)	<100	<200	<100	<300	<150	<500	<200	<900	<200	<200	<700	<200	<1000	<400	<1500	<400	<400	<1200	<400
Response time (2) [ms]											≤ 13							≤ 20	
Hysteresis [% of max regulation]											≤ 0,1							≤ 0,1	
Repeatability [% of max regulation]											± 0,1							± 0,1	
Thermal drift	zero point displacement < 1% at ΔT = 40°C																		

(1) referred to spool in neutral position and 50°C oil temperature

(2) 0-100% step signal

9 ELECTRICAL CHARACTERISTICS

Power supplies	Nominal : +24 VDC Rectified and filtered : VRMS = 20 ÷ 32 VMAX (ripple max 10 % VPP)			
Max power consumption	35 W			
Analog input signals	Voltage: range ±10 VDC (24 VMAX tollerant) Current: range ±20 mA		Input impedance: Ri > 50 kΩ Input impedance: Ri = 500 Ω	
Monitor outputs	Output range: voltage ±10 VDC @ max 5 mA current ±20 mA @ max 500 Ω load resistance			
Enable input	Range: 0 ÷ 5 Vdc (OFF state), 9 ÷ 24 Vdc (ON state), 5 ÷ 9 Vdc (not accepted); Input impedance: Ri > 10 kΩ			
Fault output	Output range: 0 ÷ 24 Vdc (ON state > [power supply - 2 V] ; OFF state < 1 V) @ max 50 mA; external negative voltage not allowed (e.g. due to inductive loads)			
Position transducers power supply	+24 Vdc @ max 100 mA and +5 Vdc @ max 100 mA are software selectable; ±10 Vdc @ max 14 mA minimum load resistance 700 Ω			
Pressure/Force transducer power supply (only for SF, SL)	+24VDC @ max 100 mA (E-ATRA-7 see tech table GX800)			
Alarms	Solenoid not connected/short circuit, cable break with current reference signal, over/under temperature, valve spool transducer malfunctions, alarms history storage function			
Insulation class	H (180°) Due to the occuring surface temperatures of the solenoid coils, the European standards ISO 13732-1 and EN982 must be taken into account			
Protection degree to DIN EN60529	IP66 / IP67 with mating connectors			
Duty factor	Continuous rating (ED=100%)			
Tropicalization	Tropical coating on electronics PCB			
Additional characteristics	Short circuit protection of solenoid's current supply; 3 leds for diagnostic; spool position control by P.I.D. with rapid solenoid switching; protection against reverse polarity of power supply			
Electromagnetic compatibility (EMC)	According to Directive 2014/30/UE (Immunity: EN 61000-6-2; Emission: EN 61000-6-3)			
Communication interface	USB	CANopen	PROFIBUS DP	EtherCAT, POWERLINK, EtherNet/IP, PROFINET IO RT / IRT EC 61158
	Atos ASCII coding	EN50325-4 + DS408	EN50170-2/IEC61158	
Communication physical layer	not insulated USB 2.0 + USB OTG	optical insulated CAN ISO 11898	optical insulated RS485	Fast Ethernet, insulated 100 Base TX

Note: a maximum time of 800 ms (depending on communication type) have be considered between the controller energizing with the 24 Vdc power supply and when the valve is ready to operate. During this time the current to the valve coils is switched to zero.

10 SEALS AND HYDRAULIC FLUIDS - for other fluids not included in below table, consult our technical office

Seals, recommended fluid temperature	NBR seals (standard) = -20°C ÷ +60°C, with HFC hydraulic fluids = -20°C ÷ +50°C FKM seals (/PE option) = -20°C ÷ +80°C HNBR seals (/BT option) = -40°C ÷ +60°C, with HFC hydraulic fluids = -40°C ÷ +50°C			
Recommended viscosity	20 ÷ 100 mm ² /s - max allowed range 15 ÷ 380 mm ² /s			
Max fluid contamination level	normal operation	ISO4406 class 18/16/13	NAS1638 class 7	see also filter section at www.atos.com or KTF catalog
	longer life	ISO4406 class 16/14/11	NAS1638 class 5	
Hydraulic fluid	Suitable seals type	Classification		Ref. Standard
Mineral oils	NBR, FKM, HNBR	HL, HLP, HLPD, HVLP, HVLPD		DIN 51524
Flame resistant without water	FKM	HFDU, HFDR		ISO 12922
Flame resistant with water	NBR, HNBR	HFC		

 The ignition temperature of the hydraulic fluid must be 50°C higher than the max solenoid surface temperature

(1) Performance limitations in case of flame resistant fluids with water:

- max operating pressure = 210 bar
- max fluid temperature = 50°C

11 CERTIFICATION DATA

Valve type	DLHZA, DLKZA		
Certifications	Multicertification Group II ATEX IECEx		
Solenoid certified code	OZA-TEZ		
Type examination certificate (1)	• ATEX: TUV IT 18 ATEX 068 X	• IECEx: IECEx TPS 19.0004X	
Method of protection	• ATEX 2014/34/EU Ex II 2G Ex db IIC T6/T5/T4 Gb Ex II 2D Ex tb IIIC T85°C/T100°C/T135°C Db	• IECEx Ex db IIC T6/T5/T4 Gb Ex tb IIIC T85°C/T100°C/T135°C Db	
Temperature class	T6	T5	T4
Surface temperature	≤ 85 °C	≤ 100 °C	≤ 135 °C
Ambient temperature (2)	-40 ÷ +40 °C	-40 ÷ +55 °C	-40 ÷ +70 °C
Applicable Standards	EN 60079-0 EN 60079-1	EN 60079-31 IEC 60079-0	IEC 60079-1 IEC 60079-31
Cable entrance: threaded connection	M = M20x1,5		

(1) The type examiner certificates can be downloaded from www.atos.com

(2) The controller and solenoids are certified for minimum ambient temperature -40°C.

In case the complete valve must withstand with minimum ambient temperature -40°C, select **/BT** in the model code.



WARNING: service work performed on the valve by the end users or not qualified personnel invalidates the certification

12 CABLE SPECIFICATION AND TEMPERATURE - Power supply and grounding cables have to comply with following characteristics:

Power supply and signals: section of wire = 1,0 mm ²	Grounding: section of external ground wire = 4 mm ²
--	---

12.1 Cable temperature

The cable must be suitable for the working temperature as specified in the "safety instructions" delivered with the first supply of the products.

Max ambient temperature [°C]	Temperature class	Max surface temperature [°C]	Min. cable temperature [°C]
40 °C	T6	85 °C	80 °C
55 °C	T5	100 °C	90 °C
70 °C	T4	135 °C	110 °C

13 CABLE GLANDS

Cable glands with threaded connections M20x1,5 for standard or armoured cables have to be ordered separately, see tech table **KX800**

Note: a Loctite sealant type 545, should be used on the cable gland entry threads

14 HYDRAULIC OPTIONS

B = Solenoid, integral electronics and position transducer at side of port A of the main stage. For hydraulic configuration vs reference signal, see 17.1

Y = Option /Y is mandatory if the pressure in port T exceeds 210 bar

15 ELECTRONIC OPTIONS

I = It provides 4 ÷ 20 mA current reference signal, instead of the standard ±10 VDC.

Input signal can be reconfigured via software selecting between voltage and current, within a maximum range of ±10 Vdc or ±20 mA.

It is normally used in case of long distance between the machine control unit and the valve or where the reference signal can be affected by electrical noise; the valve functioning is disabled in case of reference signal cable breakage.

C = Only for **SF, SL**

Option /C is available to connect pressure (force) transducers with 4 ÷ 20 mA current output signal, instead of the standard ±10 Vdc.

Input signal can be reconfigured via software selecting between voltage and current, within a maximum range of ±10 Vdc or ±20 mA.

16 POSSIBLE COMBINED OPTIONS

For SN: /BI, /BY, /IY

For SF, SL: /BI, /BY, /IY, /CI, /BCI, CIY, BCIY

17 DIAGRAMS (based on mineral oil ISO VG 46 at 50 °C)

17.1 Regulation diagrams

1 = Linear spools L

2 = Differential - linear spool D7

3 = Differential non linear spool DT7

4 = Non linear spool T5 (only for DLHZA)

5 = Non linear spool, T3 (only for DLKZA) and T7

6 = Progressive spool V

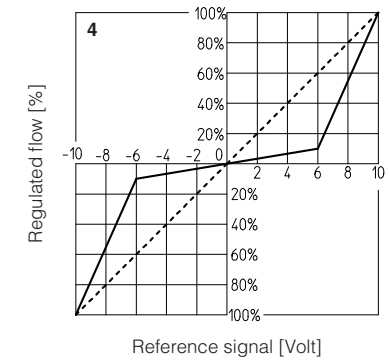
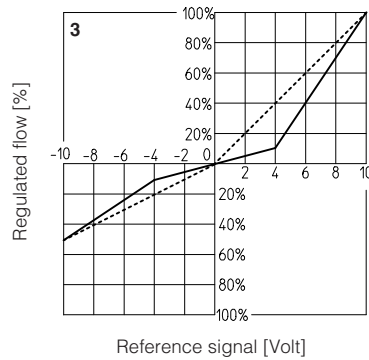
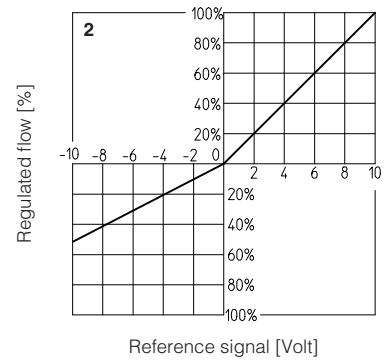
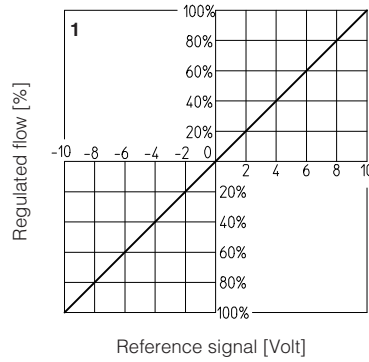

T5 and T7 spool types are specific for fine low flow control in the range from 0 to 60% (T5) and 0 to 40% (T3 and T7) of max spool stroke.

The non linear characteristics of the spool is compensated by the electronic driver, so the final valve regulation is resulting linear respect the reference signal (dotted line).

DT7 has the same characteristic of T7 but it is specific for applications with cylinders with area ratio 1:2

Note:

Hydraulic configuration vs. reference signal:

Standard:

Reference signal $\left. \begin{matrix} 0 \div +10 \text{ V} \\ 12 \div 20 \text{ mA} \end{matrix} \right\} P \rightarrow A / B \rightarrow T$

Reference signal $\left. \begin{matrix} 0 \div -10 \text{ V} \\ 12 \div 4 \text{ mA} \end{matrix} \right\} P \rightarrow B / A \rightarrow T$

option /B:

Reference signal $\left. \begin{matrix} 0 \div +10 \text{ V} \\ 12 \div 20 \text{ mA} \end{matrix} \right\} P \rightarrow B / A \rightarrow T$

Reference signal $\left. \begin{matrix} 0 \div -10 \text{ V} \\ 12 \div 4 \text{ mA} \end{matrix} \right\} P \rightarrow A / B \rightarrow T$

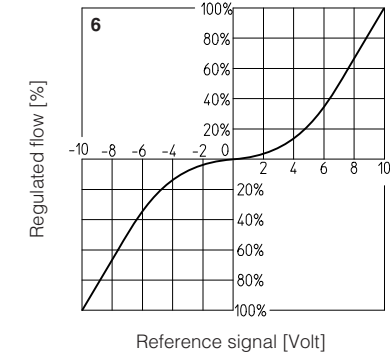
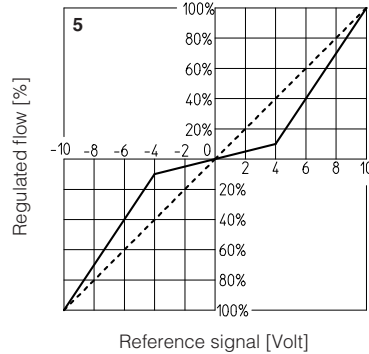

17.2 Pressure gain

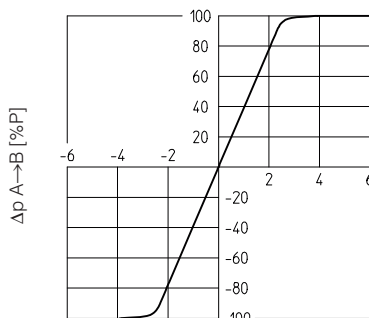
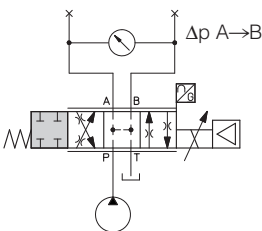

17.3 Bode diagrams

Stated at nominal hydraulic conditions

DLHZA:

1 = ± 100% nominal stroke

2 = ± 5% nominal stroke

DLKZA:

3 = ± 100% nominal stroke

4 = ± 5% nominal stroke

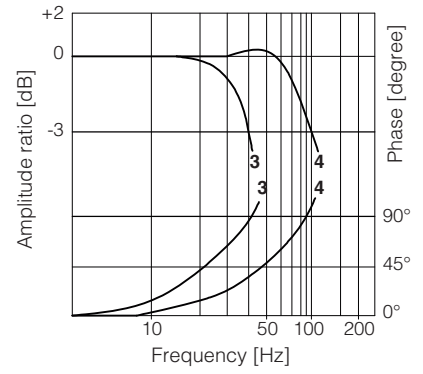
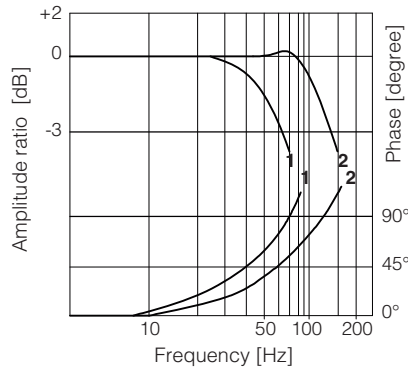

18 FAIL SAFE POSITION

CONFIGURATION	LINEAR	NOT LINEAR
<p>fail safe 1</p>	<p>$t = 7-10$ ms (DLHZA) $t = 15-20$ ms (DLKZA)</p>	<p>$t = 7-10$ ms (DLHZA) $t = 15-20$ ms (DLKZA)</p>
<p>fail safe 3</p>	<p>$t = 7-10$ ms (DLHZA) $t = 15-20$ ms (DLKZA)</p>	<p>$t = 7-10$ ms (DLHZA) $t = 15-20$ ms (DLKZA)</p>
<p>without fail safe</p>		

t = time required by the valve to switch from central to fail safe position at the power switch-off, with pressure 0 to 100 bar

Fail safe connections		P → A	P → B	A → T	B → T
Leakage [cm ³ /min] at P = 100 bar (1)	Fail safe 1	50	70	70	50
	Fail safe 3	50	70	-	-
Flow [l/min] (2)	DLHZA	-	-	15÷30	10÷20
	DLKZA	-	-	40÷60	25÷40

(1) Referred to spool in fail safe position and 50°C oil temperature

(2) Referred to spool in fail safe position at $\Delta p = 35$ bar per edge

19 POWER SUPPLY AND SIGNALS SPECIFICATIONS

Generic electrical output signals of the valve (e.g. fault or monitor signals) must not be directly used to activate safety functions, like to switch-ON/OFF the machine's safety components, as prescribed by the European standards (Safety requirements of fluid technology systems and components-hydraulics, EN-982).

19.1 Power supply (V+ and V0)

The power supply must be appropriately stabilized or rectified and filtered: apply at least a 10000 μ F/40 V capacitance to single phase rectifiers or a 4700 μ F/40 V capacitance to three phase rectifiers.

 A safety fuse is required in series to each power supply: 2,5 A time lag fuse.

19.2 Power supply for driver's logic and communication (VL+ and VL0)

The power supply for controller's logic and communication must be appropriately stabilized or rectified and filtered: apply at least a 10000 μ F/40 V capacitance to single phase rectifiers or a 4700 μ F/40 V capacitance to three phase rectifiers.

The separate power supply for controller's logic on pin 3 and 4, allow to remove solenoid power supply from pin 1 and 2 maintaining active the diagnostics, USB and fieldbus communications.

 A safety fuse is required in series to each driver's logic and communication power supply: 500 mA fast fuse.

19.3 Position reference input signal (P_INPUT+)

Functionality of P_INPUT+ signal (pin 10), depends on controller's reference mode, see section 2 :

External analog reference generation (see 2.1): input is used as reference for the controller axis position closed loop.

Reference input signal is factory preset according to selected valve code, defaults are ± 10 VDC for standard and $4 \div 20$ mA for /I option.

Input signal can be reconfigured via software selecting between voltage and current, within a maximum range of ± 10 VDC or ± 20 mA.

Fieldbus/internal reference generation (see 2.2): analog reference input signal can be used as on-off commands with input range $0 \div 24$ VDC.

19.4 Pressure or force reference input signal (F_INPUT+) - only for SF, SL

Functionality of F_INPUT+ signal (pin 12), depends on selected controllers' reference mode and alternated control options, see section 3 :

SF, SL controls and external analog reference selected : input is used as reference for the controller pressure/force closed loop.

Reference input signal is factory preset according to selected valve code, defaults are ± 10 VDC for standard and $4 \div 20$ mA for /I option.

Input signal can be reconfigured via software selecting between voltage and current, within a maximum range of ± 10 VDC or ± 20 mA.

SN control or fieldbus/internal reference selected: analog reference input signal can be used as on-off commands with input range $0 \div 24$ VDC.

19.5 Position monitor output signal (P_MONITOR)

The controller generates an analog output signal (pin 9) proportional to the actual axis position; the monitor output signal can be software set to show other signals available in the controller (e.g. analog reference, fieldbus reference, position error, valve spool position).

Monitor output signal is factory preset according to selected valve code, defaults are ± 10 Vdc for standard and $4 \div 20$ mA for /I option.

Output signal can be reconfigured via software selecting between voltage and current, within a maximum range of ± 10 VDC or ± 20 mA.

19.6 Pressure or force monitor output signal (F_MONITOR) - only for SF, SL

The controller generates an analog output signal (pin 11) according to alternated pressure/force control option:

SN control: output signal is proportional to the actual valve spool position

SF, SL controls: output signal is proportional to the actual pressure/force applied to the cylinder's rod end

Monitor output signals can be software set to show other signals available in the controller (e.g. analog reference, force reference).

The output range and polarity are software selectable within the maximum range ± 10 VDC or ± 20 mA.

Monitor output signal is factory preset according to selected valve code, defaults are ± 10 Vdc for standard and $4 \div 20$ mA for /I option.

Output signal can be reconfigured via software selecting between voltage and current, within a maximum range of ± 10 VDC or ± 20 mA.

19.7 Enable input signal (ENABLE)

To enable the controller, a 24VDC voltage has to be applied on pin 6.

When the Enable signal is set to zero the controller can be software set to perform one of the following actions:

- maintain the actuator actual position in close loop control
- move towards a predefined position in closed loop control and maintains the reached position (hold position)
- move forward or backward in open loop (only the valve's closed loop remain active)

19.8 Fault output signal (FAULT)

Fault output signal indicates fault conditions of the controller (solenoid short circuits/not connected, reference or transducer signal cable broken, maximum error exceeded, etc.). Fault presence corresponds to 0 Vdc, normal working corresponds to 24 VDC.

Fault status is not affected by the Enable input signal.

Fault output signal can be used as digital output by software selection.

19.9 Position transducer input signal

A position transducer must be always directly connected to the controller. Select the correct controller execution depending on the desired transducer interface: digital SSI or Encoder (D execution), potentiometer or a generic transducer with analog interface (A execution).

Position digital input signal is factory preset to binary SSI, it can be reconfigured via software selecting between binary/gray SSI and Encoder.

Position analog input signal is factory preset according to selected valve code, defaults are ± 10 VDC for standard and $4 \div 20$ mA for /C option.

Input signal can be reconfigured via software selecting between voltage and current, within a maximum range of ± 10 VDC or ± 20 mA.

Refer to position transducer characteristics to select the transducer type according to specific application requirements (see 20.1).

19.10 Remote pressure/force transducer input signals - only for SF, SL

Analog remote pressure transducers or load cell can be directly connected to the controller.

Analog input signal is factory preset according to selected valve code, defaults are ± 10 Vdc for standard and $4 \div 20$ mA for /C option.

Input signal can be reconfigured via software selecting between voltage and current, within a maximum range of ± 10 Vdc or ± 20 mA.

Refer to pressure/force transducer characteristics to select the transducer type according to specific application requirements (see 20.2).

20 ACTUATOR'S TRANSDUCER CHARACTERISTICS

20.1 Position transducers

The accuracy of the position control is strongly dependent to the selected position transducer. Four different transducer interfaces are available on the controllers, depending to the system requirements: potentiometer or analog signal (A execution), SSI or Encoder (D execution). Transducers with digital interface allow high resolution and accurate measures, that combined with fieldbus communication grants highest performances. Transducers with analog interface grant simple and cost effective solutions.

20.2 Pressure/force transducers

The accuracy of the pressure/force control is strongly dependent to the selected pressure/force transducer, see section **3**. Alternated pressure/force controls require to install pressure transducers or load cell to measure the actual pressure/force values. Pressure transducers allow easy system integration and cost effective solution for both alternated position/pressure and position/force controls (see tech table **GX800** for pressure transducers details). Load cell transducers allow the user to get high accuracy and precise regulations for alternated position/force control. The characteristics of the remote pressure/force transducers must be always selected to match the application requirements and to obtain the best performances: transducer nominal range should be at least 115%÷120% of the maximum regulated pressure/force.

20.3 Transducers characteristics & interfaces - following values are just for reference, for details please consult the transducer's datasheet

Execution	Position				Pressure/Force
	A	Analog	D	D	SF, SL
Input type	Potentiometer	Analog	SSI (3)	Incremental Encoder	Analog
Power supply (1)	±10 Vdc	+24 Vdc	+5 Vdc / +24 Vdc	+5 Vdc / +24 Vdc	+24 Vdc
Controller Interface	±10V	0 ÷ 10V 4 ÷ 20 mA	Serial SSI binary/gray	TTL 5Vpp - 150 KHz	±10 Vdc 4 ÷ 20 mA
Max speed	0,5 m/s	1 m/s	2 m/s	2 m/s	-
Max Resolution	< 0.4 % FS	< 0.2 % FS	1 µm	1 µm (@ 0.15 m/s)	< 0.4 % FS
Linearity error (2)	± 0.1% FS	< ±0.03% FS	< ± 0.01 % FS	< ± 0.001 % FS	< ±0.25% FS
Repeatability (2)	± 0.05% FS	< ± 0.005% FS	< ± 0.001 % FS	< ± 0.001 % FS	< ±0.1% FS

(1) Power supply provided by Atos controller **(2)** Percentage of total stroke **(3)** For Balluff BTL7 with SSI interface only special code SA433 is supported

21 TERMINAL BOARD OVERVIEW

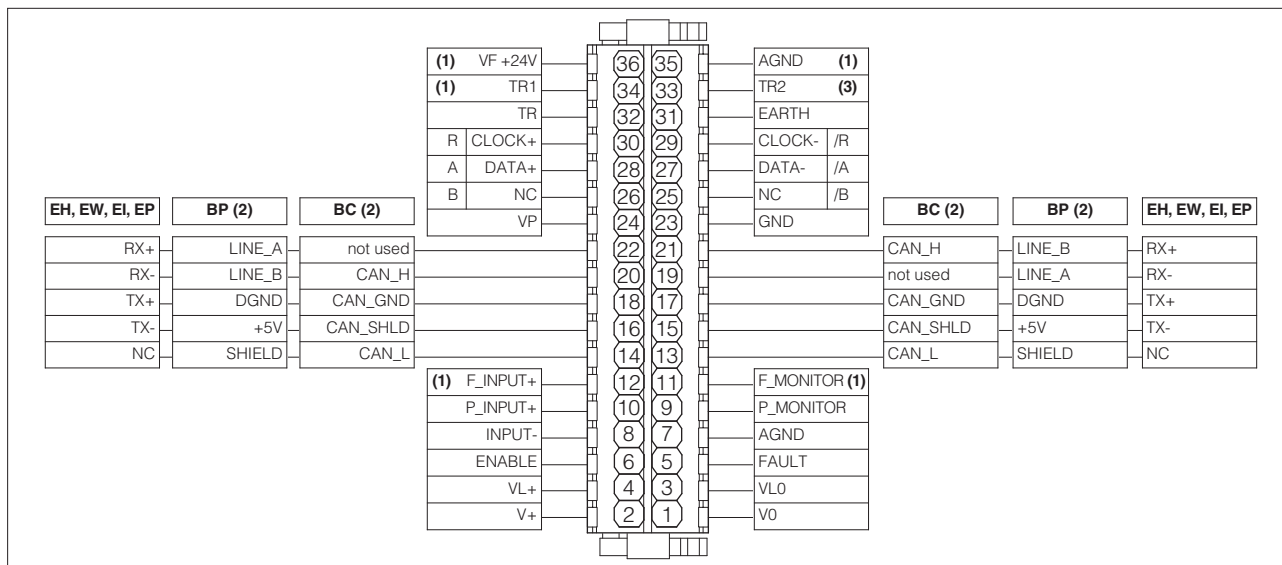

(1) Connections available only for **SF, SL**
(2) For BC and BP executions the fieldbus connections have an internal pass-through connection
(3) Connection available only for **SF**

22 ELECTRONIC CONNECTIONS

22.1 Main connections signals

CABLE ENTRANCE	PIN	SIGNAL	TECHNICAL SPECIFICATIONS	NOTES
A	1	V0	Power supply 0 Vdc	Gnd - power supply
	2	V+	Power supply 24 Vdc	Input - power supply
	3	VL0	Power supply 0 Vdc for driver's logic and communication	Gnd - power supply
	4	VL+	Power supply 24 Vdc for driver's logic and communication	Input - power supply
	5	FAULT	Fault (0 Vdc) or normal working (24 Vdc), referred to VL0	Output - on/off signal
	6	ENABLE	Enable (24 Vdc) or disable (0 Vdc) the driver, referred to VL0	Input - on/off signal
	7	AGND	Analog ground	Gnd - analog signal
	8	INPUT-	Negative reference input signal for P_INPUT+ and F_INPUT+	Input - analog signal
	9	P_MONITOR	Position monitor output signal: ± 10 Vdc / ± 20 mA maximum range, referred to AGND Defaults are: ± 10 Vdc for standard and $4 \div 20$ mA for // option	Output - analog signal Software selectable
	10	P_INPUT+	Position reference input signal: ± 10 Vdc / ± 20 mA maximum range Defaults are: ± 10 Vdc for standard and $4 \div 20$ mA for // option	Input - analog signal Software selectable
	11	F_MONITOR	Pressure/Force (SF, SL controls) or valve spool position (SN control) monitor output signal: ± 10 Vdc / ± 20 mA maximum range, referred to AGND Defaults are: ± 10 Vdc for standard and $4 \div 20$ mA for // option	Output - analog signal Software selectable
	12	F_INPUT+	Pressure/Force reference input signal (SF, SL controls): ± 10 Vdc / ± 20 mA max. range Defaults are: ± 10 Vdc for standard and $4 \div 20$ mA for // option	Input - analog signal Software selectable
31	EARTH	Internally connected to driver housing		

22.2 USB connector - M12 - 5 pin always present

CABLE ENTRANCE	PIN	SIGNAL	TECHNICAL SPECIFICATIONS	Driver view	
B	1	+5V_USB	Power supply		
	2	ID	Identification		
	3	GND_USB	Signal zero data line		
	4	D-	Data line -		
	5	D+	Data line +		

22.3 BC fieldbus execution connections

CABLE ENTRANCE	PIN	SIGNAL	TECHNICAL SPECIFICATIONS
C1	14	CAN_L	Bus line (low)
	16	CAN_SHLD	Shield
	18	CAN_GND	Signal zero data line
	20	CAN_H	Bus line (high)
	22	not used	Pass-through connection (1)

CABLE ENTRANCE	PIN	SIGNAL	TECHNICAL SPECIFICATIONS
C2	13	CAN_L	Bus line (low)
	15	CAN_SHLD	Shield
	17	CAN_GND	Signal zero data line
	19	not used	Pass-through connection (1)
	21	CAN_H	Bus line (high)

(1) Pin 19 and 22 can be fed with external +5V supply of CAN interface

22.4 BP fieldbus execution connections

CABLE ENTRANCE	PIN	SIGNAL	TECHNICAL SPECIFICATIONS
C1	14	SHIELD	
	16	+5V	Power supply
	18	DGND	Data line and termination signal zero
	20	LINE_B	Bus line (low)
	22	LINE_A	Bus line (high)

CABLE ENTRANCE	PIN	SIGNAL	TECHNICAL SPECIFICATIONS
C2	13	SHIELD	
	15	+5V	Power supply
	17	DGND	Data line and termination signal zero
	19	LINE_A	Bus line (high)
	21	LINE_B	Bus line (low)

22.5 EH, EW, EI, EP fieldbus execution connections

CABLE ENTRANCE	PIN	SIGNAL	TECHNICAL SPECIFICATIONS
C1 (input)	14	NC	do not connect
	16	TX-	Transmitter
	18	TX+	Transmitter
	20	RX-	Receiver
	22	RX+	Receiver

CABLE ENTRANCE	PIN	SIGNAL	TECHNICAL SPECIFICATIONS
C2 (output)	13	NC	do not connect
	15	TX-	Transmitter
	17	TX+	Transmitter
	19	RX-	Receiver
	21	RX+	Receiver

22.6 Remote pressure transducer connections - only for SF, SL

CABLE ENTRANCES	PIN	SIGNAL	TECHNICAL SPECIFICATIONS	NOTES	SL - Single transducer (1) Voltage	SL - Single transducer (1) Current	SF - Double transducers (1) Voltage	SF - Double transducers (1) Current
D1	33	TR2	2nd signal transducer ± 10 Vdc / ± 20 mA maximum range	Input - analog signal Software selectable	/	/	Connect	Connect
	34	TR1	1st signal transducer ± 10 Vdc / ± 20 mA maximum range	Input - analog signal Software selectable	Connect	Connect	Connect	Connect
D2	35	AGND	Common gnd for transducer power and signals	Common gnd	Connect	/	Connect	/
	36	VF +24V	Power supply +24Vdc	Output - power supply	Connect	Connect	Connect	Connect

E-ATRA remote pressure transducer connection - see tech table GX800

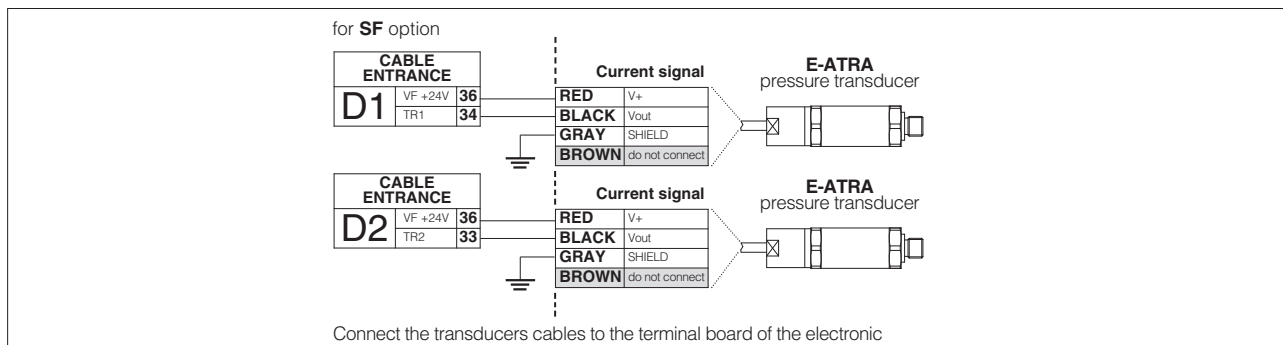

22.7 D execution - Digital position transducers connections

CABLE ENTRANCE	PIN	SSI - default transducer (1)			Encoder (1)		
		SIGNAL	TECHNICAL SPECIFICATION	NOTES	SIGNAL	TECHNICAL SPECIFICATION	NOTES
E	30	CLOCK+	Serial synchronous clock (+)	Input - digital signal	R	Input channel R	Input - digital signal
	29	CLOCK-	Serial synchronous clock (-)		/R	Input channel /R	
	28	DATA+	Serial position data (+)		A	Input channel A	
	27	DATA-	Serial position data (-)		/A	Input channel /A	
	26	NC	Not connect	Do not connect	B	Input channel B	
	25	NC			/B	Input channel /B	
	24	VP	Power supply: +24Vdc, +5Vdc or OFF (default OFF)	Output - power supply Software selectable	VP	Power supply: +24Vdc, +5Vdc or OFF (default OFF)	Output - power supply Software selectable
23	GND	Common gnd for transducer power and signals	Common gnd	GND	Common gnd for transducer power and signals	Common gnd	

(1) Digital position transducer type is software selectable: Encoder or SSI, see 19.9

SSI connection - example

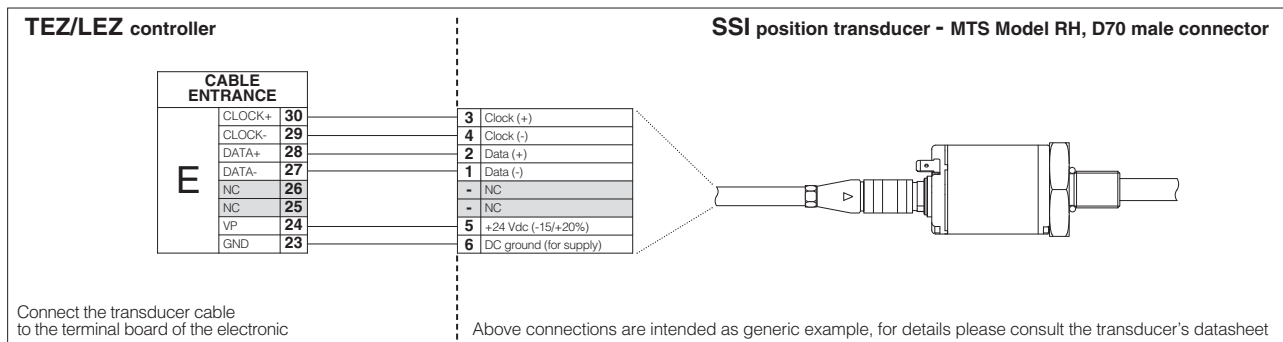

Encoder connection - example

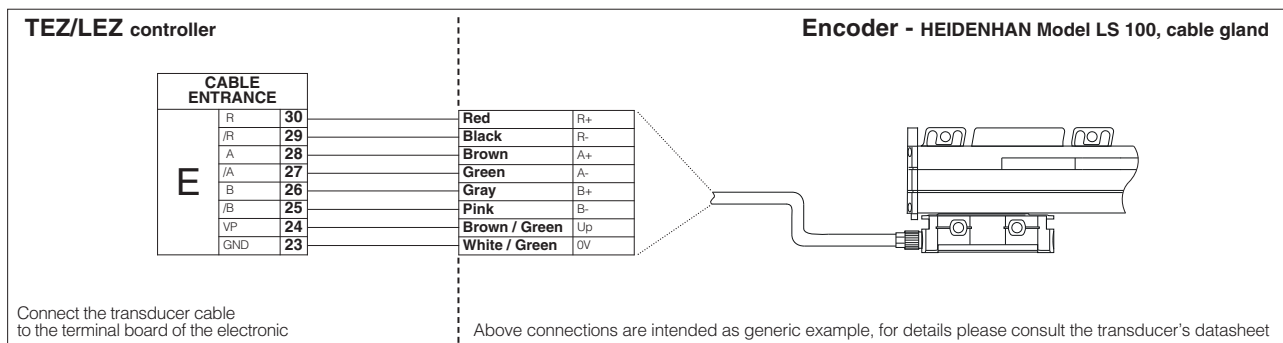

22.8 A execution - Analog position transducers connector

CABLE ENTRANCE	PIN	SIGNAL	TECHNICAL SPECIFICATION	NOTES
E	32	TR	Signal transducer	Input - analog signal
	24	VP	Power supply: +24Vdc or OFF (default OFF)	Output - power supply Software selectable
	23	GND	Common gnd for transducer power and signals	Common gnd

CABLE ENTRANCE OVERVIEW

Cables entrance description:

- (A) main connections
- (B) USB connector always present (factory plugged)
- (C1) fieldbus (input)
- (C2) fieldbus (output)
- (D1) pressure transducer 1
- (D2) pressure transducer 2
- (E) position transducer
- (P) threaded plug

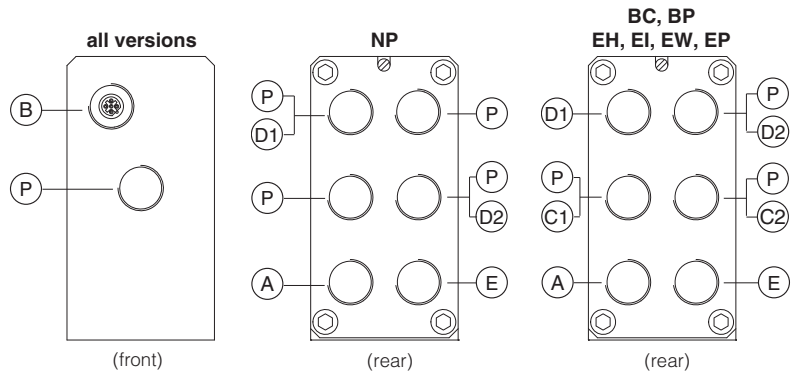

TERMINAL BOARD AND FIELDBUS TERMINATOR

Remove the 4 screws of driver's rear cover to access terminal board and fieldbus terminator

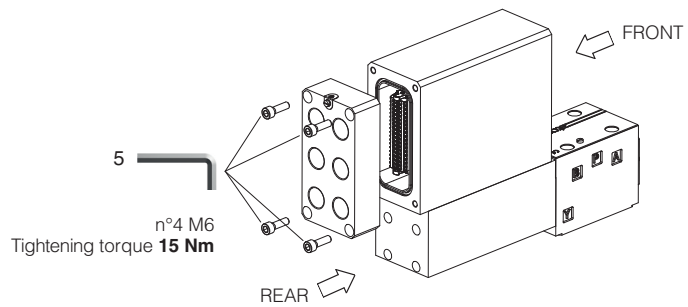

WARNING: the above operation must be performed in a safety area

Terminal board - see section 21

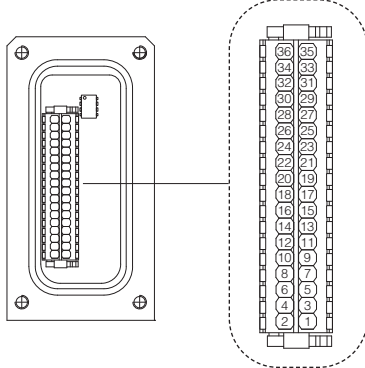

Fieldbus terminator only for BC and BP executions (1)

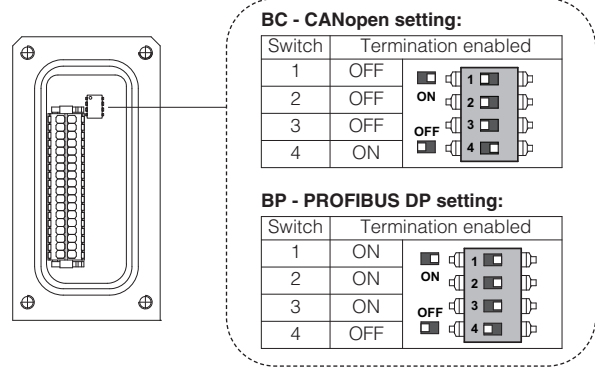

USB CONNECTOR

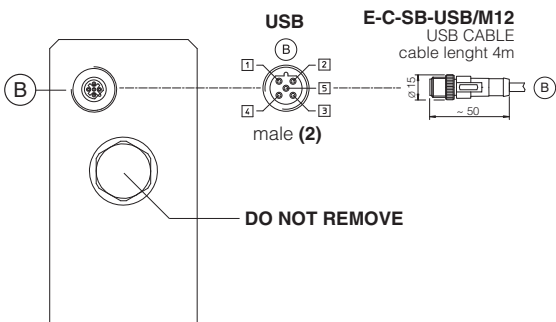

METALLIC PROTECTION CAP - supplied with the valves

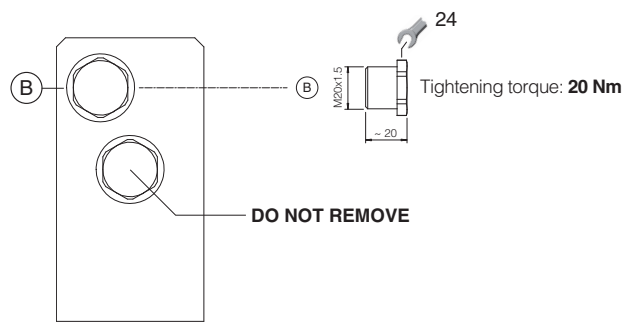

(1) Drivers with BC and BP fieldbus interface are delivered by default 'Not Terminated'. All switches are set OFF
 (2) Pin layout always referred to driver's view

23.1 Cable glands and threaded plug for SN - see tech table KX800

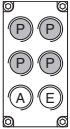
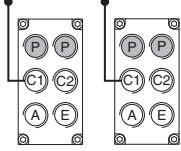
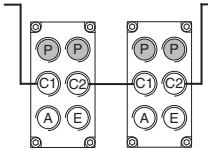
Communication interfaces	To be ordered separately				Cable entrance overview	Notes
	Cable gland quantity	entrance	Threaded plug quantity	entrance		
NP	2	A - E	none	none		Cable entrance A, E are open for costumers Cable entrance P are factory plugged
BC, BP, EH, EW, EI, EP "via stub" connection	3	C1 A - E	1	C2		Cable entrance A, E, C1, C2 are open for costumers Cable entrance P are factory plugged
BC, BP, EH, EW, EI, EP "daisy chain" connection	4	C1 - C2 A - E	none	none		Cable entrance A, E, C1, C2 are open for costumers Cable entrance P are factory plugged

23.2 Cable glands and threaded plug for SL - see tech table KX800

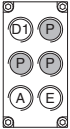
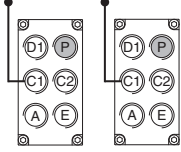
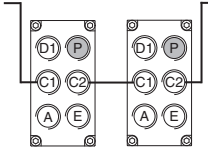
Communication interfaces	To be ordered separately				Cable entrance overview	Notes
	Cable gland quantity	entrance	Threaded plug quantity	entrance		
NP	3	D1 A - E	none	none		Cable entrance A, E, D1 are open for costumers Cable entrance P are factory plugged
BC, BP, EH, EW, EI, EP "via stub" connection	4	D1 C1 A - E	1	C2		Cable entrance A, E, C1, C2, D1 are open for costumers Cable entrance P are factory plugged
BC, BP, EH, EW, EI, EP "daisy chain" connection	5	D1 C1 - C2 A - E	none	none		Cable entrance A, E, C1, C2, D1 are open for costumers Cable entrance P are factory plugged

23.3 Cable glands and threaded plug for SF - see tech table KX800

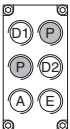
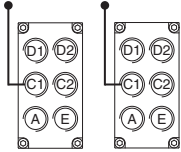
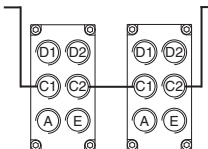
Communication interfaces	To be ordered separately				Cable entrance overview	Notes
	Cable gland quantity	entrance	Threaded plug quantity	entrance		
NP	4	D1 D2 A - E	none	none		Cable entrance A, E, D1, D2 are open for costumers Cable entrance P are factory plugged
BC, BP, EH, EW, EI, EP "via stub" connection	5	D1 - D2 C1 A - E	1	C2		Cable entrance A, E, C1, C2, D1, D2 are open for costumers
BC, BP, EH, EW, EI, EP "daisy chain" connection	6	D1 - D2 C1 - C2 A - E	none	none		Cable entrance A, E, C1, C2, D1, D2 are open for costumers

24 MAIN SOFTWARE PARAMETER SETTINGS

For a detailed descriptions of the available settings, wirings and installation procedures, please refer to the user manuals included in the Z-SW programming software:

Z-MAN-RA-LEZ - user manual for **TEZ** and **LEZ** with **SN**

Z-MAN-RA-LEZ-S - user manual for **TEZ** and **LEZ** with **SF, SL**

24.1 External reference and transducer parameters

Allow to configure the controller reference and transducer inputs, analog or digital, to match the specific application requirements:

- *Scaling parameters* define the correspondence of these signals with the specific actuator stroke or force to be controlled
- *Limit parameters* define maximum/minimum stroke and force to detect possible alarm conditions
- *Homing parameters* define the startup procedure to initialize incremental transducer (e.g. Encoder)

24.2 PID control dynamics parameters

Allow to optimize and adapt the controller closed loop to the wide range of hydraulic system characteristics:

- *PID parameters* each part of the closed loop algorithm (proportional, integral, derivative, feed forward, fine positioning, etc) can be modified to match the application requirements

24.3 Monitoring parameters

Allow to configure the controller monitoring function of the positioning error (difference between actual reference and feedback) and detects anomalous conditions:

- *Monitoring parameters* maximum allowed errors can be set for both static and dynamic positioning phases, and dedicated waiting times can be set to delay the activation of the alarm condition and relevant reaction (see 24.4)

24.4 Fault parameters

Allow to configure how the controller detects and reacts to alarm conditions:

- *Diagnostics parameters* define different conditions, threshold and delay time to detect alarm conditions
- *Reaction parameters* define different actions to be performed in case of alarm presence (stop at actual or preprogrammed position, emergency forward/backward, controller disabling, etc.)

24.5 Valve characteristics compensation



Allow to modify the valve regulation to match the actuator/system characteristics and to obtain the best overall performances:

- *Valve parameters* modify the standard valve regulation by means of deadband compensation, curve linearization and differentiated gain for positive and negative regulation

24.6 Motion phases parameters

When the internal reference generation is active a pre-programmed cycle can be generated; start/stop/switch-over commands and reference generation types parameters can be set to design a customized sequence of motion phases adapted to the specific application requirements (see 2.2).

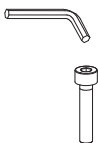
25 FASTENING BOLTS AND SEALS

	DLHZA	DLKZA
	<p>Fastening bolts: 4 socket head screws M5x50 class 12.9 Tightening torque = 8 Nm</p>	<p>Fastening bolts: 4 socket head screws M6x40 class 12.9 Tightening torque = 15 Nm</p>
	<p>Seals: 4 OR 108; Diameter of ports A, B, P, T: Ø 7,5 mm (max) 1 OR 2025 Diameter of port Y: Ø = 3,2 mm (only for /Y option)</p>	<p>Seals: 5 OR 2050; Diameter of ports A, B, P, T: Ø 11,2 mm (max) 1 OR 108 Diameter of port Y: Ø = 5 mm (only for /Y option)</p>

DLHZA-TEZ

ISO 4401: 2005

Mounting surface: 4401-03-02-0-05 (see table P005)

(for /Y surface: 4401-03-03-0-05 without port X)

Mass [kg]	
DLHZA-TEZ	7,2

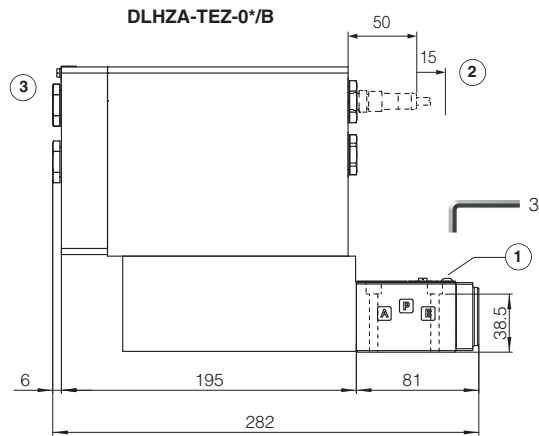
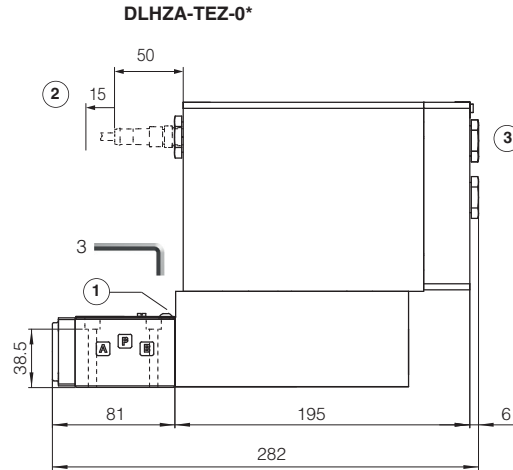
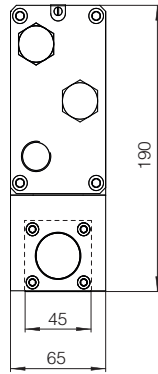

- ① = Air bleed off
- ② = Space to remove the USB connector
- ③ = The dimensions of cable glands must be considered (see tech table **KX800**)

DLKZA-TEZ

ISO 4401: 2000

Mounting surface: 4401-05-04-0-05 (see table P005)
(for /Y surface 4401-05-05-0-05 without X port)

Mass [kg]	
DLKZA-TEZ	9

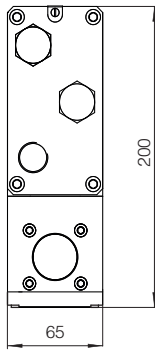

DLKZA-TEZ-1*

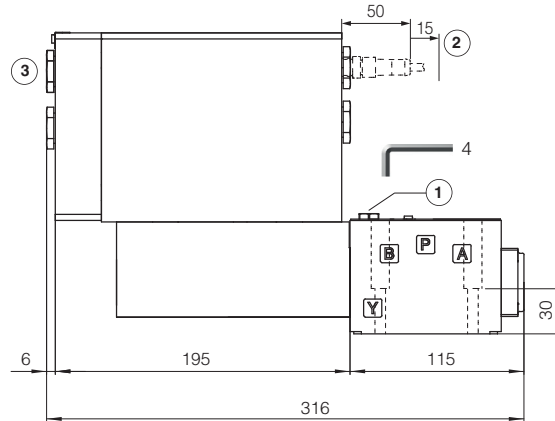

DLKZA-TEZ-1*/B

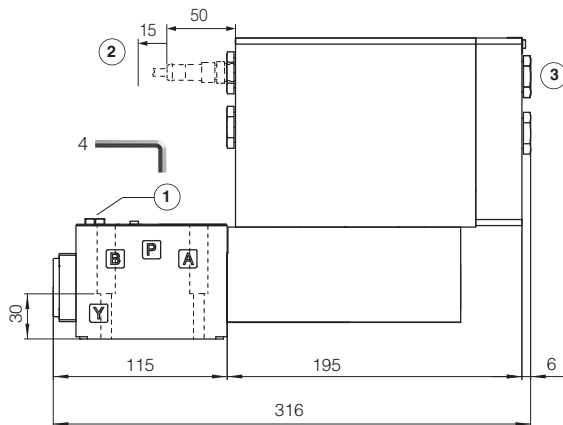

- ① = Air bleed off
- ② = Space to remove the USB connector
- ③ = The dimensions of cable glands must be considered (see tech table **KX800**)

27 RELATED DOCUMENTATION

X010	Basics for electrohydraulics in hazardous environments
X020	Summary of Atos ex-proof components certified to ATEX, IECEx, EAC, PESO
FX900	Operating and maintenance information for ex-proof proportional valves
GS500	Programming tools

GS510	Fieldbus
GX800	Ex-proof pressure transducer type E-ATRA-7
KX800	Cable glands for ex-proof valves
P005	Mounting surfaces for electrohydraulic valves