

Fluid contamination

Fluid contamination defines the presence of foreign particles and substances into the hydraulic fluid, classified in 3 families (solid, water and air contamination), which produce different effects on hydraulic components.

This aspect is a main issue for all hydraulic systems, being responsible for failures and increased machine downtime with consequent heavy costs for end users.

The purpose of this document is to provide general information about type, sources and effects of fluid contamination on hydraulic components.

In particular it is focused on the solid contamination, most commonly present in hydraulic systems, with a description of international methods for its measurement and classification.

1 SOLID CONTAMINATION

It is responsible for wearing and damages of hydraulic components causing approximately 80% of hydraulic systems failures.

Solid contaminants can enter into the hydraulic system from the external environment or they can be generated during the system operation. A detailed analysis about the potential causes of fluid contamination is described in section 4

Effects: solid contamination causes accelerated wear and sticking phenomena, with consequent increased internal leakages and inaccurate regulation of hydraulic components. In the worst cases it may lead to the components breakage.

A detailed analysis of the effects of solid contamination on hydraulic components is described in section 5

Removal methods: the solid contamination cannot be completely removed but it can be consistently reduced at acceptable levels by means of **hydraulic filters (in line and return line type)**.

Contamination coming from external environment can be also prevented using specific air filters and pressurized tanks.

An extensive description of filter types, contamination classes and suggested filtration circuits is described in the technical table LF020

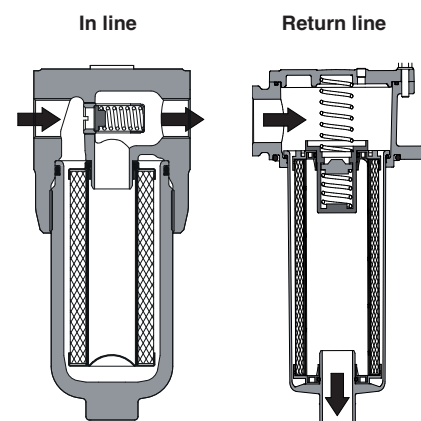

2 WATER CONTAMINATION

Water can be present into the hydraulic fluid as dissolved water (emulsion) or free water, depending to its concentration and fluid temperature.

Water can enter into the hydraulic system during oil filling operations, through the tank cover or by the air moisture present in the ambient.

Effects: water contamination causes oxidation and corrosion of metal parts, plus alteration of chemical properties of the hydraulic fluid.

Removal methods: sealed tanks are normally used in case of system out-doors installation to prevent water dropping.

Centrifugal separators are a valid solution to remove the water emulsion from the hydraulic fluid.

Breather filters are normally used to remove the humidity form the air entering the oil tank.

Note: consult Atos Technical Office for detailed information about water contamination removal

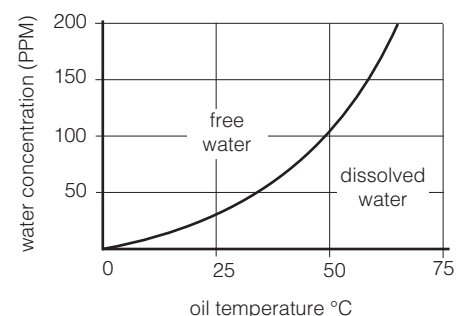

3 AIR CONTAMINATION

Air is always present into the hydraulic system before its commissioning, or it can be introduced during maintenance.

Effects: the presence of air may cause pumps damage due to cavitation, inaccurate valve regulation and vibrations.

Removal methods: air bleeding points are normally present in the upper side of the hydraulic system and in hydraulic components. The complete air bleeding procedure must be performed at the system commissioning or after maintenance operations.

Note: consult Atos Technical Office for detailed information about air bleeding procedures. See also www.atos.com, tech. table P002 for system commissioning

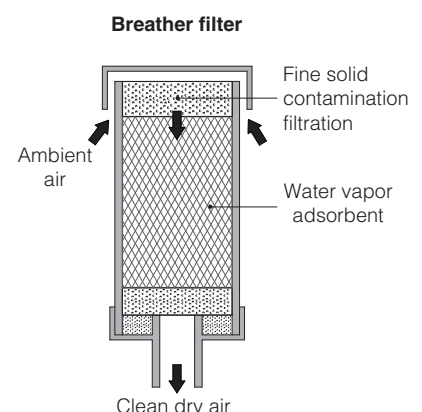

4 SOURCES OF SOLID CONTAMINATION

The solid contamination has two main sources:

- **Fluid original contamination**, caused by poor quality hydraulic fluids, or fluids stored in dirty tanks
- **System progressive contamination**, generated during the system working and caused by wearing of metal parts and rubber pipes

In a more detailed analysis, following causes of contamination can be identified:

4.1 First fluid filling

Oil coming from shipping containers usually has a contamination level higher than the standards acceptable for most hydraulic systems: oil cannot be assumed to be clean unless it has been carefully filtered.

4.2 Built-in contamination

Different contaminants can be found in new systems and they can be directly related to manufacturing and assembling operations.

4.3 Self-generated contamination

The major source of contamination directly comes from the normal hydraulic system operation. Most of contaminant are due to rubber released from the inner walls of flexible hoses, some from with moving parts of hydraulic components, like pumps and valves

4.4 External contamination

Contaminants coming from the surrounding environment can enter the hydraulic fluid through reservoir breather caps and worn cylinder rod seals.

4.5 Maintenance-induced contamination

Contaminants coming from the surrounding environment can enter the system during maintenance operations. Inaccurate cleaning of the pipes after the replacement of failed components can be the source of further contamination.

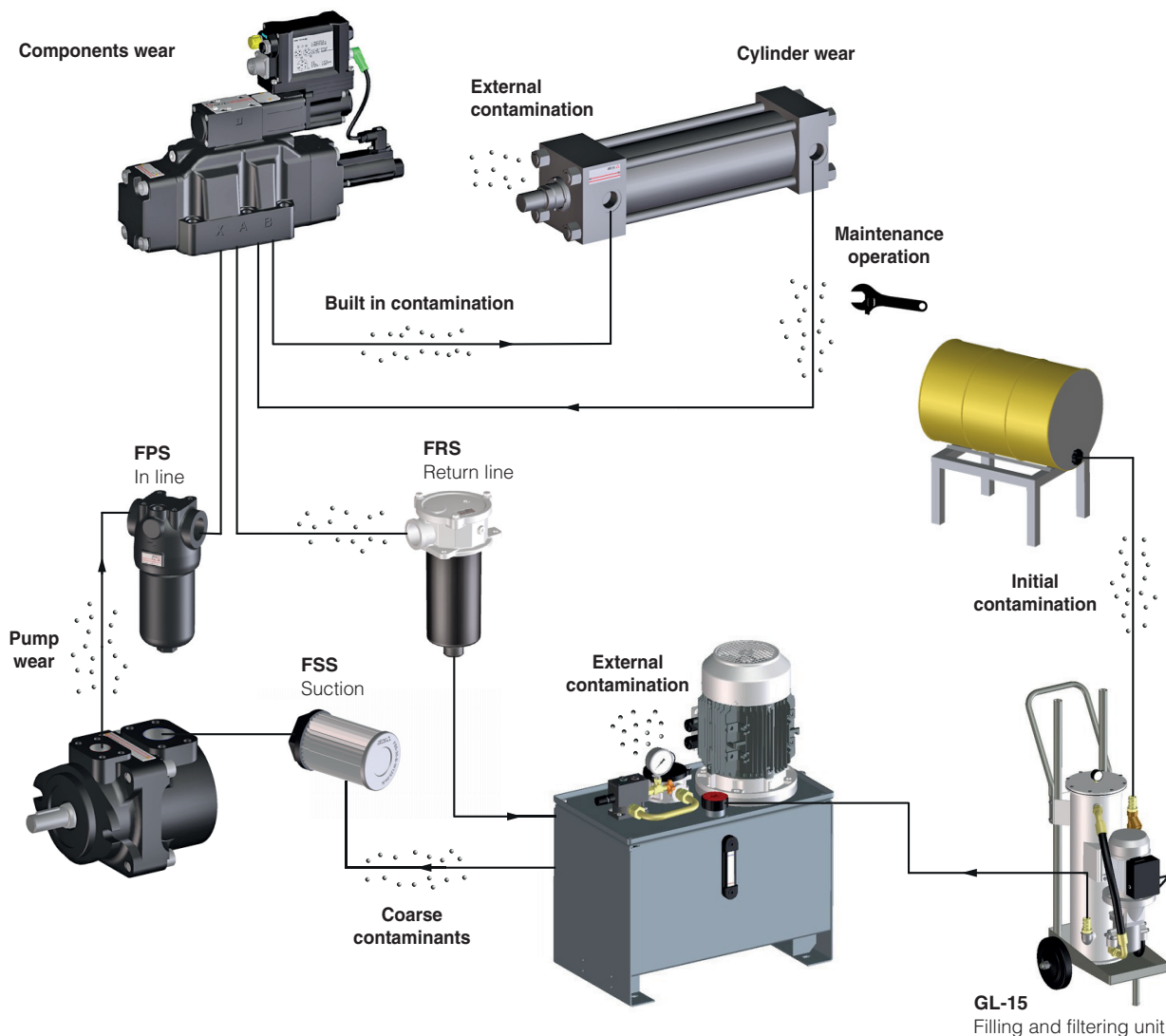

5 EFFECTS OF SOLID CONTAMINATION

The presence of solid contaminants into the hydraulic fluid have harmful effects on the correct operation and service life of hydraulic components as pumps, valves and actuators.

They mainly cause abrasion, erosion and fatigue effects on components surface with following main consequences:

- increased internal leakages
- sticking effects
- permanent wear of moving parts

Typical failures produced by solid contamination can be classified as:

- **Transitory failures**, when particles enter components causing its temporarily malfunction. The components returns to correctly operate as soon the particles are removed by the oil flow.
- **Progressive deterioration**, when particles cause micro-erosion and abrasion of the component surfaces. This failure causes a progressive degradation of performances until the functionality of the component is definitively compromised.
- **Irreparable failure**, when particles enter the gap between mobile parts causing the sudden sticking. This failure could be solved by cleaning the internal parts of the component, in the worst cases the whole components must be replaced

Typical failures in spool valve

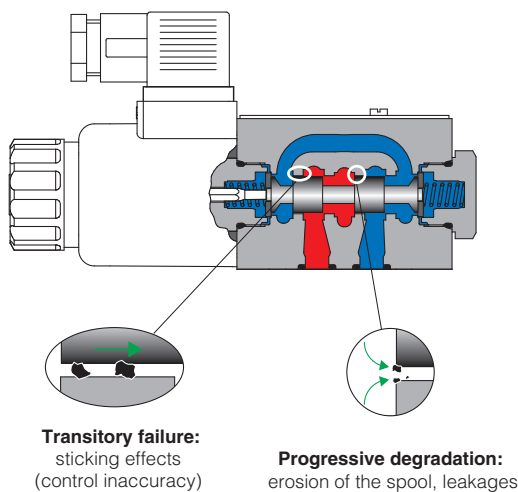

Typical failures in poppet cartridges

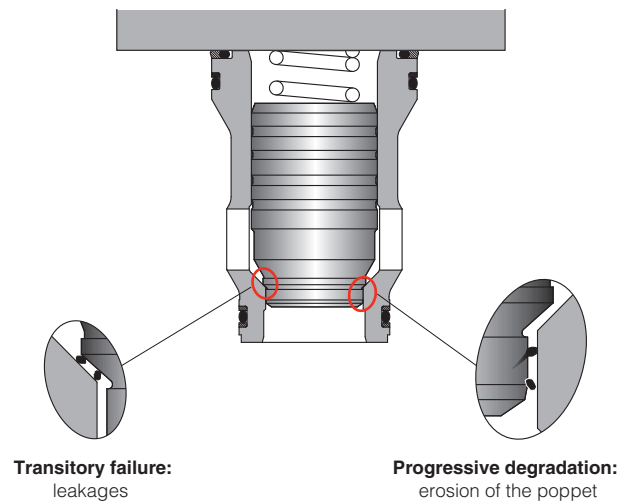

Typical failures in cylinders

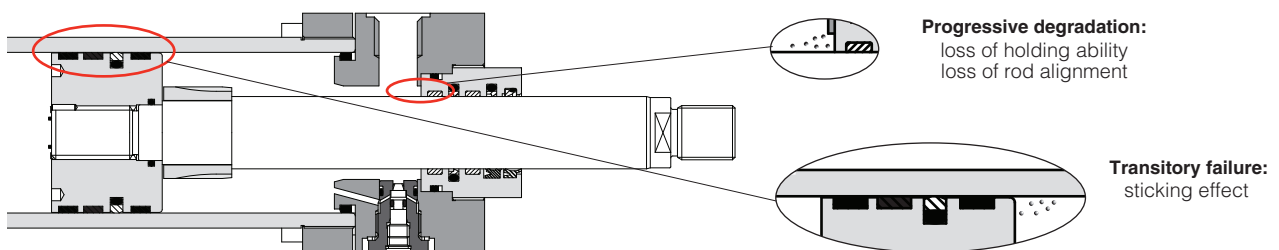

6 MEASUREMENT OF SOLID CONTAMINATION

One of the most common methods used by the industry for solid contamination analysis is the Automatic Particles Counter (APC). It is based on the principle of a light beam projected through the sample of fluid to be analyzed.

As a solid particle passes through the light beam, it results in a measurable energy drop that is proportional to the size of the particle.

This method permits to measure the quantity and dimensions of solid particles present in the fluid and it is used for the classification of the fluid contamination level, as described in section 5

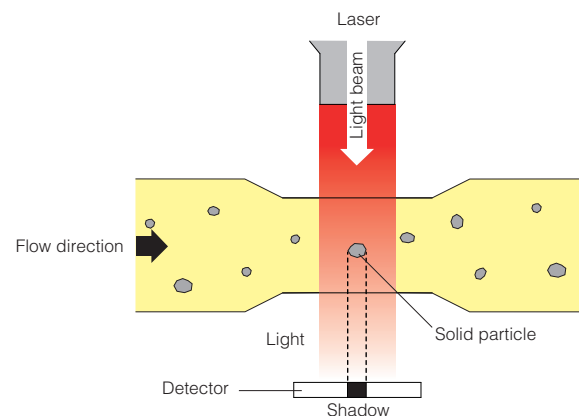

7 CLASSIFICATION OF CONTAMINATION LEVEL

The contamination level identifies the quantity and dimensions of solid particles present into the hydraulic fluid. It is classified according to the European standard ISO 4406/1999, while for North America it is classified by SAE AS 4059 or NAS 1638 standards.

7.1 ISO 4406 classification

ISO 4406 is the European standard being used extensively within the industrial hydraulics to measure and classify the fluid contamination.

The contamination level is measured by counting the number of particles of a certain dimension present into a 100 ml of fluid.

It is expressed by a combination of 3 codes, i.e: **20 / 18 / 15**, respectively identifying the quantity of contaminants with dimension $> 4 \mu\text{m}_{(c)}$, $> 6 \mu\text{m}_{(c)}$ and $> 14 \mu\text{m}_{(c)}$, as per following table

ISO CODE (to ISO 4406)	Particle quantity / 100 ml	
	from	to
5	16	32
6	32	64
7	64	130
8	130	250
9	250	500
10	500	1.000
11	1.000	2.000
12	2.000	4.000
13	4.000	8.000
14	8.000	16.000
15	16.000	32.000
16	32.000	64.000
17	64.000	130.000
18	130.000	260.000
19	260.000	500.000
20	500.000	1.000.000
21	1.000.000	2.000.000
22	2.000.000	4.000.000
23	4.000.000	8.000.000
24	8.000.000	16.000.000
25	16.000.000	32.000.000
26	32.000.000	64.000.000
27	64.000.000	130.000.000
28	130.000.000	250.000.000

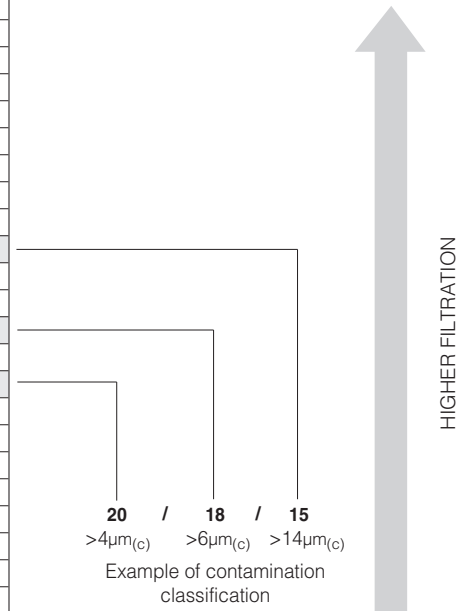

7.2 SAE AS 4059 classification

This classification is normally adopted in North America, particularly in aerospace industry. The contamination level is classified by a combination of 3 codes, i.e. **7B/6C/5D** identifying the quantity of contaminants of a certain dimension present into 100 ml of fluid

Dimensions code		A	B	C	D	E	F
Particle dimensions		$> 4 \mu\text{m}_{(c)}$	$> 6 \mu\text{m}_{(c)}$	$> 14 \mu\text{m}_{(c)}$	$> 21 \mu\text{m}_{(c)}$	$> 38 \mu\text{m}_{(c)}$	$> 70 \mu\text{m}_{(c)}$
		Particle quantity / 100 ml					
Contamination classes	000	195	76	14	3	1	0
	00	390	152	27	5	1	0
	0	780	304	54	10	2	0
	1	1.560	609	109	20	4	1
	2	3.120	1.220	217	39	7	1
	3	6.250	2.430	432	76	13	2
	4	12.500	4.860	864	152	26	4
	5	25.000	9.730	1.730	306	53	8
	6	50.000	19.500	3.460	612	106	16
	7	100.000	38.900	6.920	1.220	212	32
	8	200.000	77.900	13.900	2.450	424	64
	9	400.000	156.000	27.700	4.900	848	128
	10	800.000	311.000	55.400	9.800	1.700	256
11	1.600.000	623.000	111.000	19.600	3.390	1.020	
12	3.200.000	1.250.000	222.000	39.200	6.780		



7.3 NAS 1638 classification

NAS 1638 (National Aerospace Standard) is a type of classification used in North America.

It divides the dimensional distribution of the particles into intervals (5-15 μm , 15-25 μm , etc.) and assigns a code to each interval, according to the following table in which is reported also a comparison with ISO 4406 and SAE AS 4059 standards.

ISO 4406	SAE AS 4059	NAS 1638
14/12/09	4A/3B/3C	3
15/13/10	5A/4B/4C	4
16/14/11	6A/5B/5C	5
17/15/12	7A/6B/6C	6
18/16/13	8A/7B/7C	7
19/17/14	9A/8B/8C	8
20/18/15	10A/9B/9C	9
21/19/16	11A/10B/10C	10
22/20/17	12A/11B/11C	11
23/21/18	13A/12B/12C	12

