

Spare parts for CC cylinders

1 EXPLODED VIEW OF THE CYLINDER

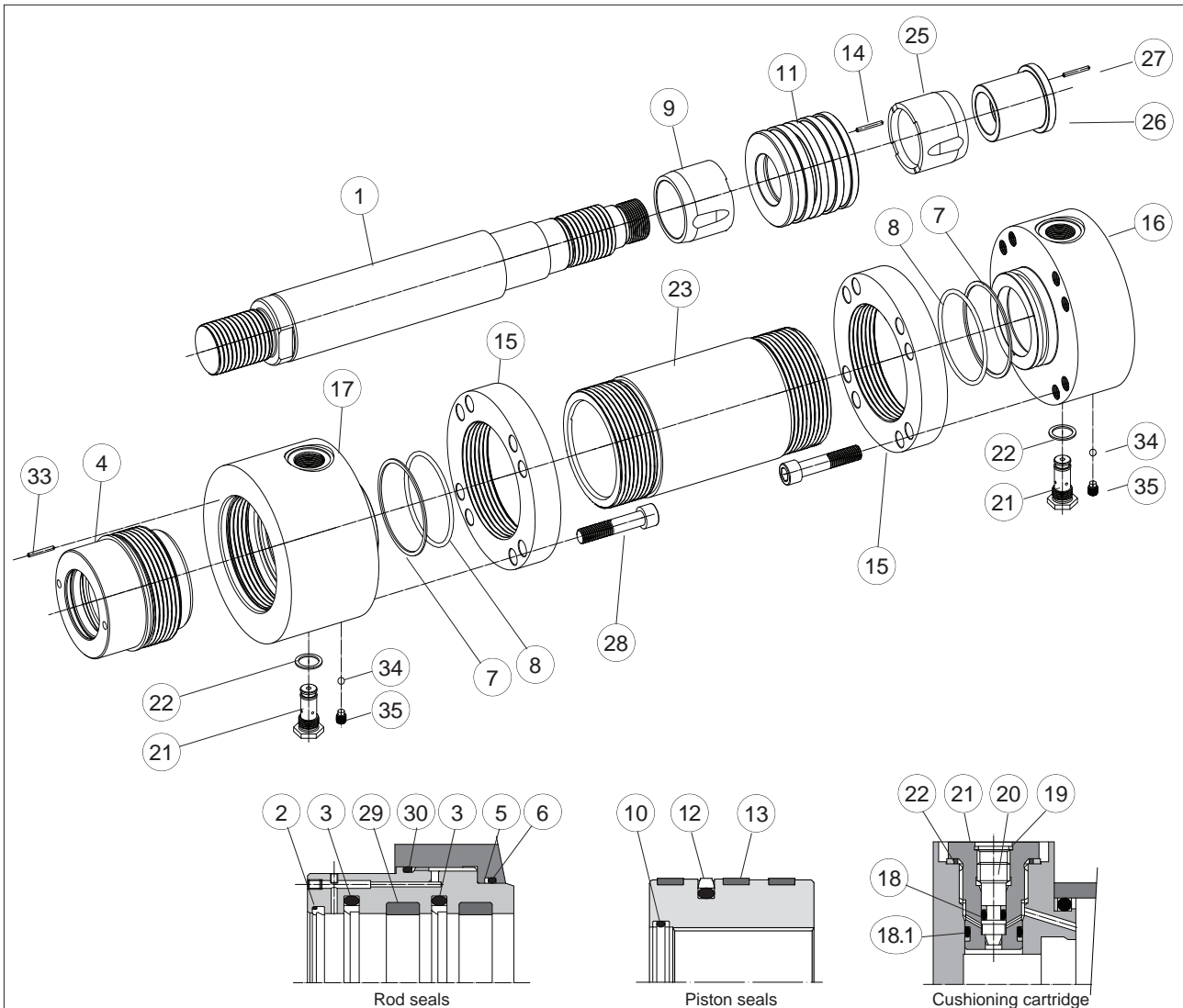

POS	DESCRIPTION	POS	DESCRIPTION
1	Rod	18.1	O-ring + Antiextrusion ring - cushioning cartridge
2	Wiper	19	Seeger
3	Rod seal	20	Cushioning adjustment screw
4	Rod seal sleeve - steel/bronze	21	Cushioning adjustment cartridge
5	Antiextrusion ring - rod sleeve	22	Seal
6	O-ring - rod sleeve	23	Cylinder housing
7	Antiextrusion ring - cylinder housing	24	O-ring - rear cushioning
8	O-ring - cylinder housing	25	Rear cushioning piston
9	Front cushioning piston	26	Rear cushioning piston socket
10	O-ring + n°2 Antiextrusion ring - piston	27	Locking pin - cushioning/piston
11	Piston	28	Screw
12	Piston seal	29	Rod wear ring
13	Piston wear rings	30	O-ring - rod sleeve
14	Locking pin - piston/rod	31	front sleeve screw, see section 3
15	Counterflange	32	Bronze rod bearing, see section 3
16	Rear head	33	Locking pin - rod seals sleeve/front head (bores 140 - 200)
17	Front head	34	Steel sphere - air bleed
18	O-ring + Antiextrusion ring - cushioning screw	35	Grub screw - air bleed

2 ROD AND PISTON SEALS

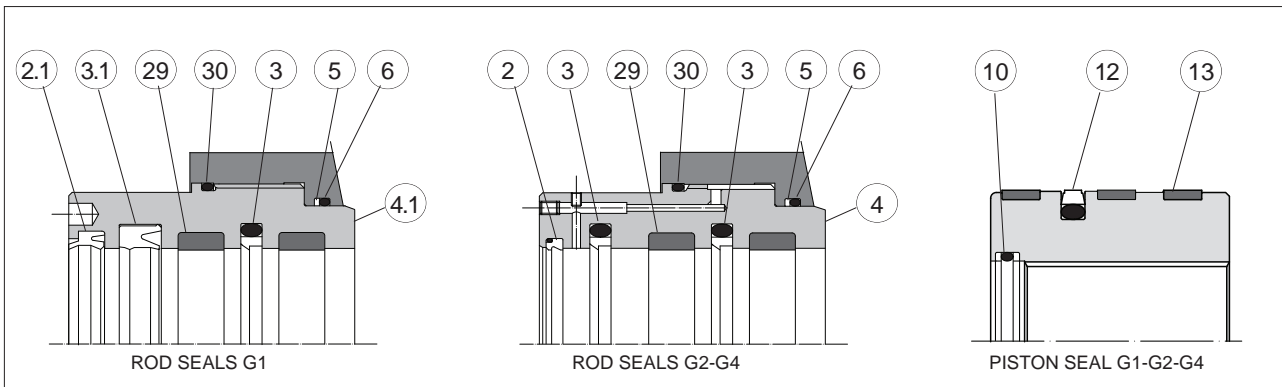

3 ROD GUIDE VARIANTS

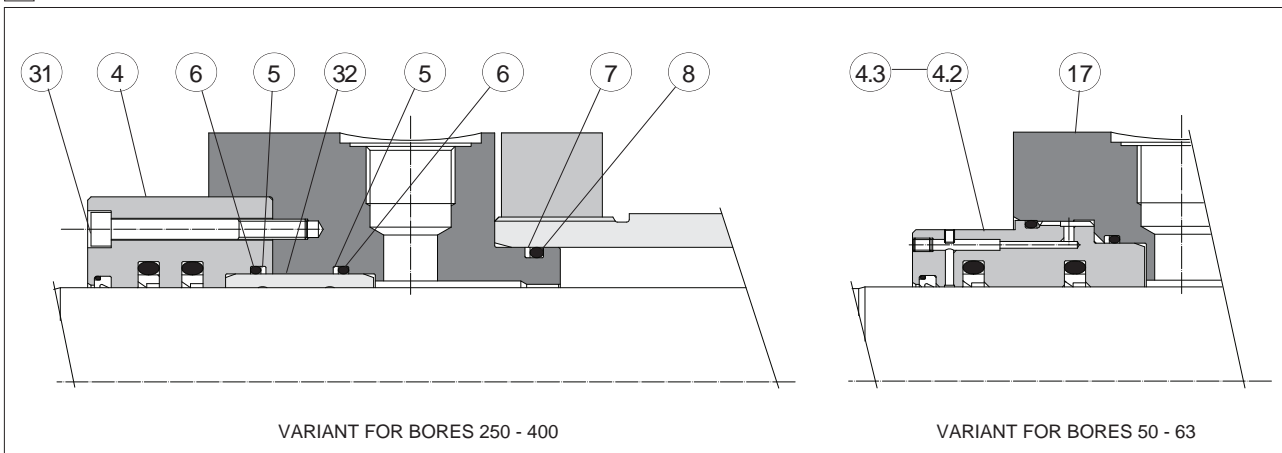

4 ASSEMBLING TOOLS

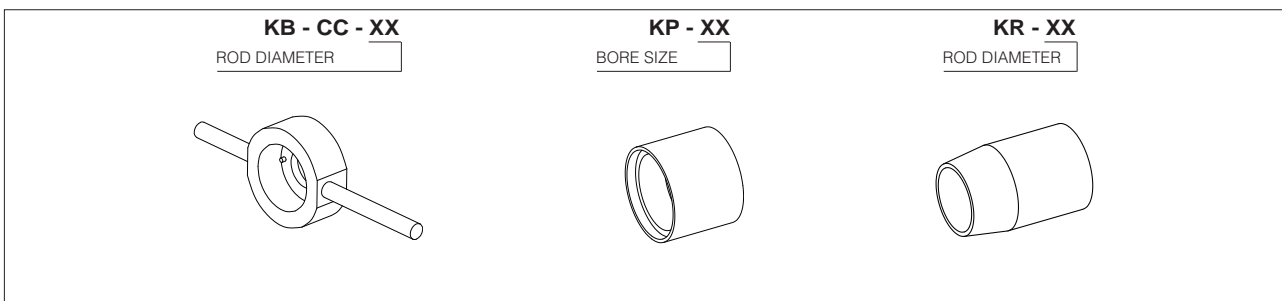

ASSEMBLING OPERATION	CYLINDER SIZE	TOOL	TOOL DIMENSION	TORQUE [Nm]
Rod seal sleeve (pos. 4) assembling	Bores 50 - 200	KB - CC - XX	According to the rod diameter	see table SP-B600, section 1
Cushioning adjustment cartridge (pos.21) assembling	Bores 50 - 320	Hexagonal wrench	22	19,6
Screws (pos. 28) for heads assembling	Bores 50 - 200	Allen key	According to the bore size	See table B241 section 3
Screws (pos. 31) for rod seals sleeve	Bore 250	Allen key	10	160
	Bore 320		14	100
Grub screw (pos. 35) for air bleed screwing	Bores 50 - 160	Allen key	4	6
	Bores 180 - 320		6	30
Calibration of piston seal	Bores 50 - 320	KP - XX	According to the bore size	-
Calibration of rod seals	Bores 50 - 320	KR - XX	According to the rod diameter	-

5 SPARE PARTS CODES

5.1 Seals

ORDER CODE	POS	DESCRIPTION	G1	G2	G4
<p>G1 - CC - 50 / 36 - 10</p> <p>G1 - v < 0,5 m/s G2 - v > 1 m/s up to 120°C G4 - v > 1 m/s</p>	2	Wiper - PTFE		•	•
	2.1	Wiper - polyurethane (ISO 6195)	•		
	3	Rod seal - PTFE (ISO 7425)		• [2]	• [2]
	3.1	Rod seal - polyurethane (ISO 5597)	•		
	5	Antiextrusion ring - rod sleeve	• [2]	• [2]	• [2]
	6	O-ring - rod sleeve	• [2]	• [2]	• [2]
	7	Antiextrusion ring - cylinder housing	• [2]	• [2]	• [2]
	8	O-ring - cylinder housing	• [2]	• [2]	• [2]
	10	O-ring + nr. 2 antiextrusion rings piston/rod	•	•	•
	12	Piston seal - PTFE (ISO 7425)	•	•	•
	13	Piston wear rings - ORKOT (G1)	• [3](a)	• [3](a)	• [3](a)
	13.1	Piston wear rings - PTFE (G2-G4)	• [3](a)	• [3](a)	• [3](a)
	14	Locking pin - piston/rod	•	•	•
	18	O-ring + Antiextrusion ring - cushioning screw	• [2]	• [2]	• [2]
	18.1	O-ring + Antiextrusion ring - cushioning cartridge	• [2]	• [2]	• [2]
	22	Seal	• [2]	• [2]	• [2]
	27	Locking pin - cushioning/piston	•	•	•
	29	Rod wear rings - ORKOT	• [3](b)	• [3](b)	• [3](b)
	30	O-ring - rod sleeve	•	•	•
	33	Locking pin - rod seals sleeve/front head	• (c)	• (c)	• (c)

5.2 Rod seal sleeve

ORDER CODE	POS	DESCRIPTION	G1	G2	G4
<p>B1 - CC - 50 / 36 - HJ - 10</p> <p>B1 - G1 B2 - G2 B4 - G4</p>	2	Wiper - PTFE		•	•
	2.1	Wiper - polyurethane (ISO 6195)	•		
	3	Rod seal - PTFE (ISO 7425)		• [2]	• [2]
	4	Rod seal sleeve - steel		•	•
	4.1	Rod seal sleeve - steel	•		
	4.2	Rod seal sleeve - bronze		• (d)	• (d)
	4.3	Rod seal sleeve - bronze	• (d)		
	5	Antiextrusion ring - rod sleeve	• [2]	• [2]	• [2]
	6	O-ring - rod sleeve	• [2]	• [2]	• [2]
	32	Rod bearing - bronze	• (e)	• (e)	• (e)

5.3 Piston rod

ORDER CODE	POS	DESCRIPTION	G1	G2	G4
<p>U - CC - 50 / 36 x 0500-X3...</p> <p>COMPLETE CYLINDER CODE + SERIES NUMBER</p>	1	Rod	•	•	•
	9	Front cushioning piston (if selected)	•	•	•
	10	O-ring + n°2 Antiextrusion ring - piston	•	•	•
	11	Piston	•	•	•
	12	Piston seal	•	•	•
	13	Piston wear rings - ORKOT (G1)	• [3](a)	• [3](a)	• [3](a)
	13.1	Piston wear rings - PTFE (G2-G4)	• [3](a)	• [3](a)	• [3](a)
	14	Locking pin - piston/rod	•	•	•
	25	Rear cushioning piston	•	•	•
	26	Rear cushioning piston socket	•	•	•
	27	Locking pin - cushioning socket/piston	•	•	•

5.4 Cushioning

ORDER CODE	POS	DESCRIPTION	Front F2	Rear F1
<p>F1 - CC - 50 / 36 - 10</p> <p>F1 - rear cushioning F2 - front cushioning</p>	9	Front cushioning piston	•	
	18	O-ring + Antiextrusion ring - cushioning screw	•	•
	18.1	O-ring + Antiextrusion ring - cushioning cartridge	•	•
	19	Seeger	•	•
	20	Cushioning adjustment screw	•	•
	21	Cushioning adjustment cartridge	•	•
	22	Seal	•	•
	25	Rear cushioning piston		•
27	Locking pin - cushioning socket/piston		•	

Notes:

- (a) Nr. 4 Piston wear rings for bores from 63 to 160
- (b) Nr. 4 rod wear rings for bore 200, No rod wear rings for bores 50, 63, 250, 320
- (c) Only for bores from 140 to 200
- (d) Replace Pos. 4 and 4.1 for bores 50 and 63
- (e) Only for bores 250 and 320