

Servoproportional 2-way cartridges high response

digital, with two position transducers, ISO 7368 sizes from 32 to 100, rugged design

Available only on request

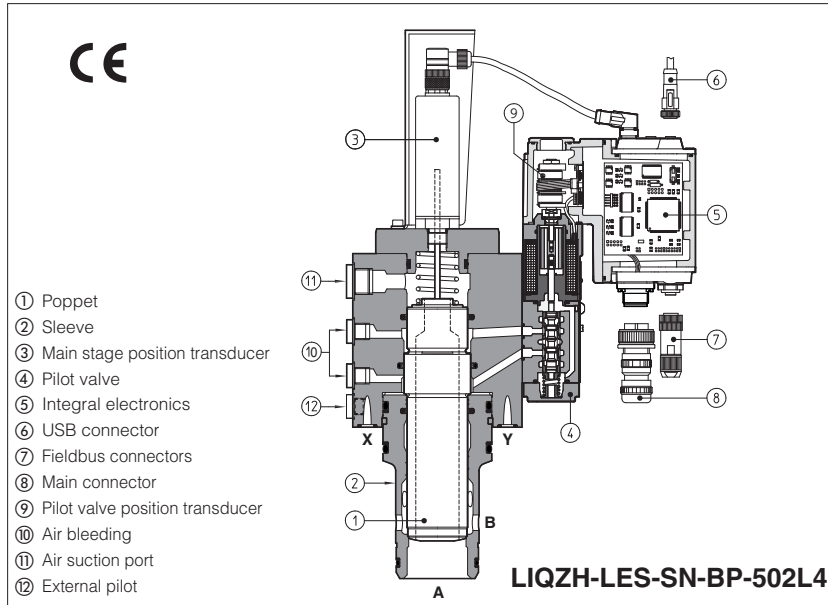

- ① Poppet
- ② Sleeve
- ③ Main stage position transducer
- ④ Pilot valve
- ⑤ Integral electronics
- ⑥ USB connector
- ⑦ Fieldbus connectors
- ⑧ Main connector
- ⑨ Pilot valve position transducer
- ⑩ Air bleeding
- ⑪ Air suction port
- ⑫ External pilot

LIQZH-LEB, LIQZH-LES

High response 2-way servoproportional cartridge valves specifically designed for high flow applications requiring maximum dynamics and accurate control.

Typical applications are die casting and fast forging presses.

They are equipped with two LVDT position transducers for best dynamics in not compensated flow regulations.

The cartridge execution for blocks installation grants high flow capabilities and minimized pressure drops.

The integral digital electronic driver performs the valve's hydraulic regulation according to the reference signal and assures valve-to-valve interchangeability thanks to the factory presetting.

High response valves are available in LEB basic execution with analog reference signals and USB port for software functional parameters setting or in LES full execution which includes also optional fieldbus interfaces for functional parameters setting, reference signals and real-time diagnostics

sizes from **32** to **100**,
Max flow: **1800** to **16.000** l/min
Max pressure: **420** bar

1 MODEL CODE

LIQZH	-	L		ES	-	SN	-	NP	-	40	2	L4	/	*	**	/	*
<p>Servoproportional cartridge high response</p> <p>L = closed-loop two LVDT transducers</p> <p>Integral digital drivers: EB = basic (1) ES = full</p> <p>Alternated P/Q controls: SN = none</p> <p>Fieldbus interfaces USB port always present: NP = Not present (1) EW = POWERLINK BC = CANopen EH = EtherCAT BP = PROFIBUS DP EI = EtherNet/IP</p> <p>Seals material, see sect. 4, 5: - = NBR PE = FKM BT = HNBR</p> <p>Series number</p> <p>Electronic options, see sections 9 I = current reference input and monitor 4÷20 mA (omit for standard voltage reference input and monitor ±10 V) F = fault signal Q = enable signal Z = double power supply (2), enable, fault and monitor signals (12 pin connector)</p> <p>Poppet type - regulating characteristics: L4 = linear </p>																	

Valve size, see section 4

size	32	40	50
l/min	800	1200	2000
size	63	80	100
l/min	3000	4500	7200

Nominal flow (l/min) at Δp 5 bar

Configuration: 2 = 2 way

functional symbol

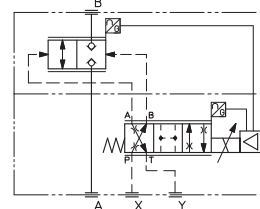

simplified symbol

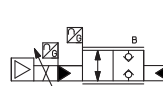

(1) LEB available only in version SN-NP (2) Double power supply only for LES

2 GENERAL NOTES

LIQZH-LEB, LES servoproportional cartridges are **CE** marked according to the applicable Directives (e.g. Immunity/Emission EMC Directive and Low Voltage Directive). Installation, wirings and start-up procedures must be performed according to the general prescriptions shown in table F003 and in the installation notes supplied with relevant components.

The electrical signals of the valve (e.g. monitor signals) must not be directly used to activate safety functions, or components, as prescribed by the European standards (Safety requirements of fluid technology systems and components-hydraulics, EN-982).

WARNING

To avoid overheating and possible damage of the electronic driver, the valves must be never energized without hydraulic supply to the pilot stage. In case of prolonged pauses of the valve operation during the machine cycle, it is always advisable to disable the driver (option /Q or /Z)

A safety fuse 2,5 A installed on 24Vdc power supply of each valve is always recommended, see also Power supply note at sections [9](#)

WARNING

The loss of the pilot pressure or the sudden interruption of the power supply during the valve operation causes the immediate shut-off of the main poppet.

This could cause pressure surges in the hydraulic system or high decelerations which may lead to machine damages.

3 FIELDBUS - only for LES

Fieldbus allows the direct communication of the proportional valve with machine control unit for digital reference signal, diagnostics and settings of functional parameters. Analog reference signal remain available on the main connector for quick commissioning and maintenance. For detailed information about fieldbus features and specification see tech table **GS510**.

4 MAIN CHARACTERISTICS - based on mineral oil ISO VG 46 at 50 °C

Assembly position	Any position			
Subplate surface finishing	Roughness index, Ra 0,4 flatness ratio 0,01/100 (ISO 1101)			
MTTFd values according to EN ISO 13849	75 years, see technical table P007			
Ambient temperature range	standard = -20°C ÷ +60°C		/BT option = -40°C ÷ +60°C	
Storage temperature range	standard = -20°C ÷ +70°C		/BT option = -40°C ÷ +70°C	
Coil resistance R at 20°C	3 ÷ 3,3 Ω			
Max. solenoid current	2,6 A			
Max. power	50 Watt			
Insulation class	H (180°) Due to the occurring surface temperatures of the solenoid coils, the European standards ISO 13732-1 and EN982 must be taken into account			
Protection degree to DIN EN60529	IP66/67 with mating connector			
Tropicalization	Tropical coating on electronics PCB			
Duty factor	Continuous rating (ED=100%)			
EMC, climate and mechanical load	See technical table G004			
Communication interface	USB Atos ASCII coding	CANopen EN50325-4 + DS408	PROFIBUS DP EN50170-2/IEC61158	EtherCAT, POWERLINK EtherNet/IP IEC 61158
Communication physical layer	not insulated USB 2.0 + USB OTG	optical insulated CAN ISO11898	optical insulated RS485	Fast Ethernet, insulated 100 Base TX

Size	32	40	50	63	80	100
Max regulated flow [l/min]						
at Δp = 5 bar	800	1200	2000	3000	4500	7200
at Δp = 10 bar	1100	1700	2800	4250	6350	10200
Max permissible flow	1800	2500	4000	6000	10000	16000
Max pressure [bar]	Ports A, B = 420 X = 350 Y ≤ 10					
Nominal flow of pilot valve at Δp = 70 bar [l/min]	20	40	40	100	100	100
Leakage of pilot valve at P = 100 bar [l/min]	0,3	0,7	0,7	1	1	1
Piloting pressure [bar]	min: 40% of system pressure max 350 recommended 140 ÷ 160					
Piloting volume [cm³]	3,31	5,34	7,42	10,28	19,55	22,53
Piloting flow (1) [l/min]	13,2	17,8	22,3	31	39	45
Response time 0 ÷ 100% step signal (2) [ms]	15	18	20	20	30	30
Hysteresis [% of the max regulation]	≤ 0,1					
Repeatability [% of the max regulation]	± 0,1					
Thermal drift	zero point displacement < 1% at ΔT = 40°C					

Note:

above performance data refer to valves coupled with Atos electronic drivers, see section [6](#).

(1) with step reference input 0÷100%

(2) with pilot pressure = 140 bar, see detailed diagrams in section 7.2

5 SEALS AND HYDRAULIC FLUID - for other fluids not included in below table, consult our technical office

Seals, recommended fluid temperature	NBR seals (standard) = -20°C ÷ +60°C, with HFC hydraulic fluids = -20°C ÷ +50°C FKM seals (/PE option) = -20°C ÷ +80°C HNBR seals (/BT option) = -40°C ÷ +60°C, with HFC hydraulic fluids = -40°C ÷ +50°C		
Recommended viscosity	20 ÷ 100 mm ² /s - max allowed range 15 ÷ 380 mm ² /s		
Fluid contamination class	ISO 4406 class 20/18/15 NAS 1638 class 9, in line filters of 10 µm (β10 ≥75 recommended)		
Hydraulic fluid	Suitable seals type	Classification	Ref. Standard
Mineral oils	NBR, FKM, HNBR	HL, HLP, HLPD, HVLP, HVLPD	DIN 51524
Flame resistant without water	FKM	HFDU, HFDR	ISO 12922
Flame resistant with water	NBR, HNBR	HFC	

6 ELECTRONIC DRIVERS

Valve model	LEB	LES
Drivers model	E-RI-LEB-N	E-RI-LES-N
Type	Digital	
Format	Integral to valve	
Data sheet	GS208	GS210

Note: for main and communication connector see sections **12**, **13**

7 DIAGRAMS (based on mineral oil ISO VG 46 at 50 °C)

7.1 Regulation diagrams (values measured at Δp 5 bar)

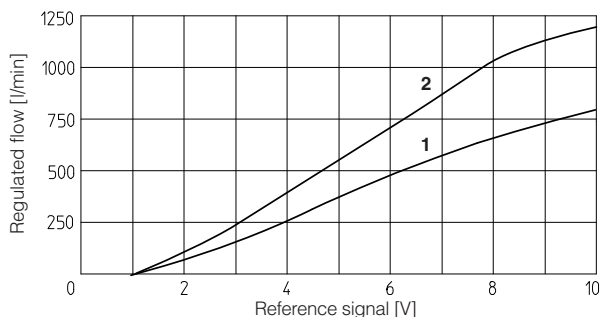

1 = LIQZH-L*-32*
2 = LIQZH-L*-40*

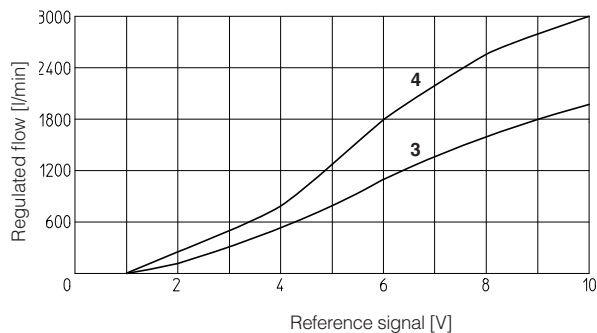

3 = LIQZH-L*-50*
4 = LIQZH-L*-63*

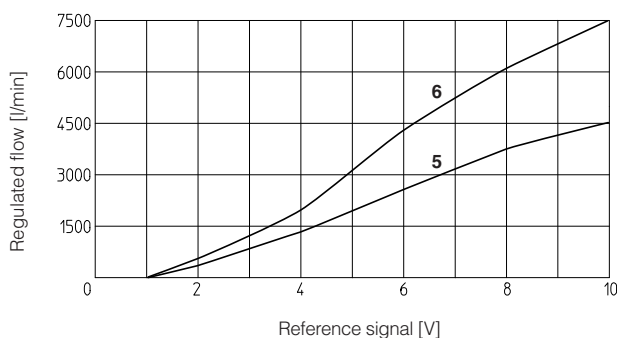

5 = LIQZH-L*-80*
6 = LIQZH-L*-100*

7.2 Response time

The response times in below diagrams are measured at different steps of the reference input signal. They have to be considered as average values. For the valves with digital electronics the dynamics performances can be optimized by setting the internal software parameters.

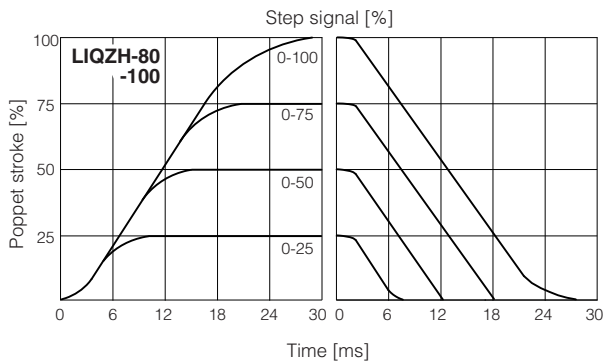
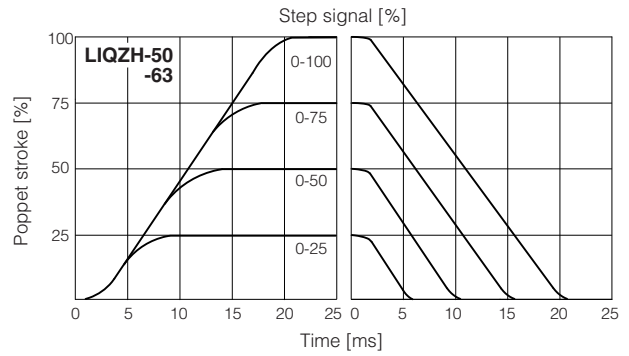
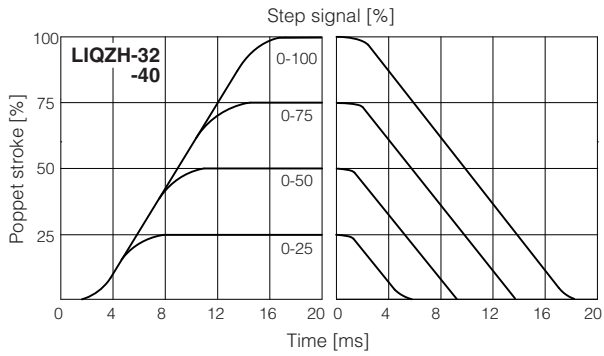

7.3 Bode diagrams - stated at nominal hydraulic conditions

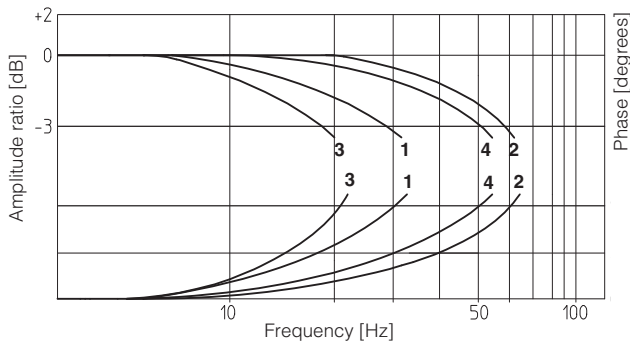

- 1 = LIQZH-L*-32*: 10% ↔ 90% 3 = LIQZH-L*-40*: 10% ↔ 90%
 2 = LIQZH-L*-32*: 50% ± 5% 4 = LIQZH-L*-40*: 50% ± 5%

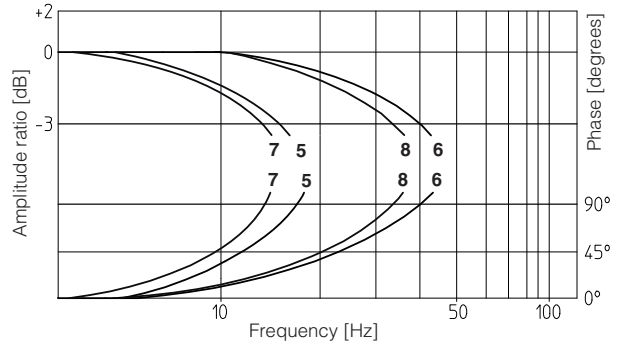

- 5 = LIQZH-L*-50*: 10% ↔ 90% 7 = LIQZH-L*-63*: 10% ↔ 90%
 6 = LIQZH-L*-50*: 50% ± 5% 8 = LIQZH-L*-63*: 50% ± 5%

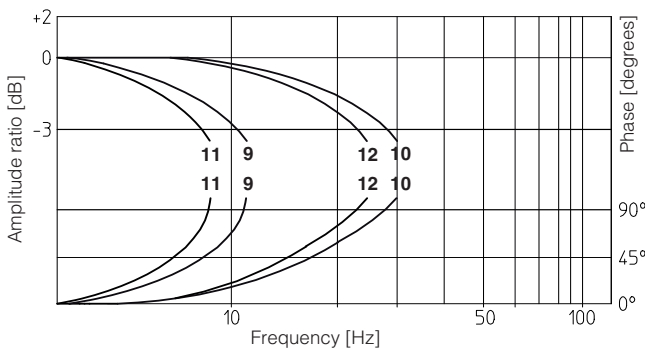

- 9 = LIQZH-L*-80*: 10% ↔ 90% 11 = LIQZH-L*-100*: 10% ↔ 90%
 10 = LIQZH-L*-80*: 50% ± 5% 12 = LIQZH-L*-100*: 50% ± 5%

8 AIR BLEEDING

Size 32 to 63

Sizes 80 to 100

① To be used only in case port A is connected to tank and subjected to negative pressure, consult our technical office.

② At the machine commissioning it is advisable to bleed the air from piloting chambers, by loosening the 2 plugs shown in the picture.
Operate the valve for few seconds at low pressure and then lock the plugs.

③ Additional external pilot port connection.

Port	LIQZH Size					
	32	40	50	63	80	100
① Air suction	G1/4" CH 6		G1/2" CH 10			
② Air bleeding			G1/4" CH 6			
③ External pilot			G1/2" CH 10			

9 ELECTRONIC OPTIONS

Standard driver execution provides on the 7 pin main connector:

Power supply - 24 VDC must be appropriately stabilized or rectified and filtered; **2,5 A** fuse time lag is required in series to each driver power supply. Apply at least a 10000 μ F/40 V capacitance to single phase rectifiers or a 4700 μ F/40 V capacitance to three phase rectifiers

Reference input signal - analog differential input with ± 10 VDC nominal range (pin D, E), proportional to desired valve poppet position

Monitor output signal - analog output signal proportional to the actual valve's poppet position with ± 10 VDC nominal range

Note: a minimum booting time between 400 and 800 ms has been considered from the driver energizing with the 24 VDC power supply before the valve has been ready to operate. During this time the current to the valve coils is switched to zero.

9.1 Option /F

It provides a Fault output signal in place of the Monitor output signal, to indicate fault conditions of the driver (cable interruption of poppet transducers or reference signal - for /I option): Fault presence corresponds to 0 VDC, normal working corresponds to 24 VDC

9.2 Option /I

It provides 4 \div 20 mA current reference and monitor signals, instead of the standard 0 \div +10 V.

Input signal can be reconfigured via software selecting between voltage and current, within a maximum range of ± 10 V or ± 20 mA.

It is normally used in case of long distance between the machine control unit and the valve or where the reference signal can be affected by electrical noise; the valve functioning is disabled in case of reference signal cable breakage.

9.3 Option /Q

To enable the driver, supply 24 VDC on pin C referred to pin B: Enable input signal allows to enable/disable the current supply to the solenoid, without removing the electrical power supply to the driver; it is used to maintain active the communication and the other driver functions when the valve has to be disabled. This condition does not comply with European Norms EN13849-1 (ex EN954-1).

9.4 Option /Z

It provides, on the 12 pin main connector, the following additional features:

Enable Input Signal

To enable the driver, supply 24 VDC on pin 3 referred to pin 2: Enable input signal allows to enable/disable the current supply to the solenoid, without removing the electrical power supply to the driver; it is used to maintain active the communication and the other driver functions when the valve has to be disabled. This condition does not comply with European Norms EN13849-1 (ex EN954-1).

Fault Output Signal

Fault output signal indicates fault conditions of the driver (solenoid short circuits/not connected, reference signal cable broken for 4 \div 20mA input, etc.). Fault presence corresponds to 0 VDC, normal working corresponds to 24 VDC (pin 11 referred to pin 2): Fault status is not affected by the Enable input signal

Power supply for driver's logics and communication - only for LES

Separate power supply (pin 9,10) allow to cut solenoid power supply (pin 1,2) while maintaining active diagnostics, USB and fieldbus communication. A safety fuse is required in series to each driver power supply: 500 mA fast fuse.

9.5 Possible combined options

/FI, /IQ and /IZ

10 ELECTRONIC CONNECTIONS AND LEDS

10.1 Main connector signals - 7 pin - standard, /F and /Q options (A1)

PIN	Standard	/Q	/F	TECHNICAL SPECIFICATIONS	NOTES
A	V+			Power supply 24 Vdc Rectified and filtered: $V_{RMS} = 20 \div 32 V_{MAX}$ (ripple max 10 % V_{PP})	Input - power supply
B	V0			Power supply 0 Vdc	Gnd - power supply
C	AGND		AGND	Analog ground	Gnd - analog signal
		ENABLE		Enable (24 Vdc) or disable (0 Vdc) the valve, referred to V0	Input - on/off signal
D	Q_INPUT+			Flow reference input signal: ± 10 Vdc / ± 20 mA maximum range Defaults are 0 \div +10 V for standard and 4 \div 20 mA for /I option	Input - analog signal Software selectable
E	INPUT-			Negative reference input signal for Q_INPUT+	Input - analog signal
F	Q_MONITOR referred to: AGND	V0		Flow monitor output signal: ± 10 Vdc / ± 20 mA maximum range Defaults are 0 \div +10 V for standard and 4 \div 20 mA for /I option	Output - analog signal Software selectable
			FAULT	Fault (0 Vdc) or normal working (24 Vdc)	Output - on/off signal
G	EARTH			Internally connected to the driver housing	

10.2 Main connector signal - 12 pin - /Z option (A2)

PIN	LEB-SN /Z	LES-SN /Z	TECHNICAL SPECIFICATIONS	NOTES
1	V+		Power supply 24 Vdc Rectified and filtered: $V_{RMS} = 20 \div 32 V_{MAX}$ (ripple max 10 % V_{PP})	Input - power supply
2	V0		Power supply 0 Vdc	Gnd - power supply
3	ENABLE referred to: V0	VL0	Enable (24 Vdc) or disable (0 Vdc) the valve	Input - on/off signal
4	Q_INPUT+		Flow reference input signal: ± 10 Vdc / ± 20 mA maximum range Defaults are 0 \div +10 V for standard and 4 \div 20 mA for /I option	Input - analog signal Software selectable
5	INPUT-		Negative reference input signal for Q_INPUT+	Input - analog signal
6	Q_MONITOR referred to: AGND	VL0	Flow monitor output signal: ± 10 Vdc / ± 20 mA maximum range Defaults are 0 \div +10 V for standard and 4 \div 20 mA for /I option	Input - analog signal Software selectable
7	AGND		Analog ground	Output - analog signal
		NC	Do not connect	Gnd - analog signal
8	R_ENABLE		Repeat enable, output repeter signal of enable input, referred to V0	
		NC	Do not connect	Output - on/off signal
9	NC		Do not connect	
		VL+	Power supply 24 Vdc for driver's logic and communication	Input - power supply
10	NC		Do not connect	
		VL0	Power supply 0 Vdc for driver's logic and communication	Gnd - power supply
11	FAULT referred to: V0	VL0	Fault (0 Vdc) or normal working (24 Vdc)	Output - on/off signal
PE	EARTH		Internally connected to the driver housing	

Note: do not disconnect VL0 before VL+ when the driver is connected to PC USB port

10.3 Communications connectors (B) - (C)

(B) USB connector - M12 - 5 pin always present		
PIN	SIGNAL	TECHNICAL SPECIFICATION (1)
1	+5V_USB	Supply for external USB Flash Drive
2	ID	USB Flash Drive identification
3	GND_USB	Signal zero data line
4	D-	Data line -
5	D+	Data line +

(C1) (C2) BC fieldbus execution, connector - M12 - 5 pin		
PIN	SIGNAL	TECHNICAL SPECIFICATION (1)
1	CAN_SHLD	Shield
2	not used	(C1) - (C2) pass-through connection (2)
3	CAN_GND	Signal zero data line
4	CAN_H	Bus line (high)
5	CAN_L	Bus line (low)

(C1) (C2) BP fieldbus execution, connector - M12 - 5 pin		
PIN	SIGNAL	TECHNICAL SPECIFICATION (1)
1	+5V	Termination supply signal
2	LINE-A	Bus line (high)
3	DGND	Data line and termination signal zero
4	LINE-B	Bus line (low)
5	SHIELD	

(C1) (C2) EH, EW, EI fieldbus execution, connector - M12 - 4 pin		
PIN	SIGNAL	TECHNICAL SPECIFICATION (1)
1	TX+	Transmitter
2	RX+	Receiver
3	TX-	Transmitter
4	RX-	Receiver
Housing	SHIELD	

Notes: (1) shield connection on connector's housing is recommended

(2): pin 2 can be fed with external +5V supply of CAN interface

10.5 Connections layout

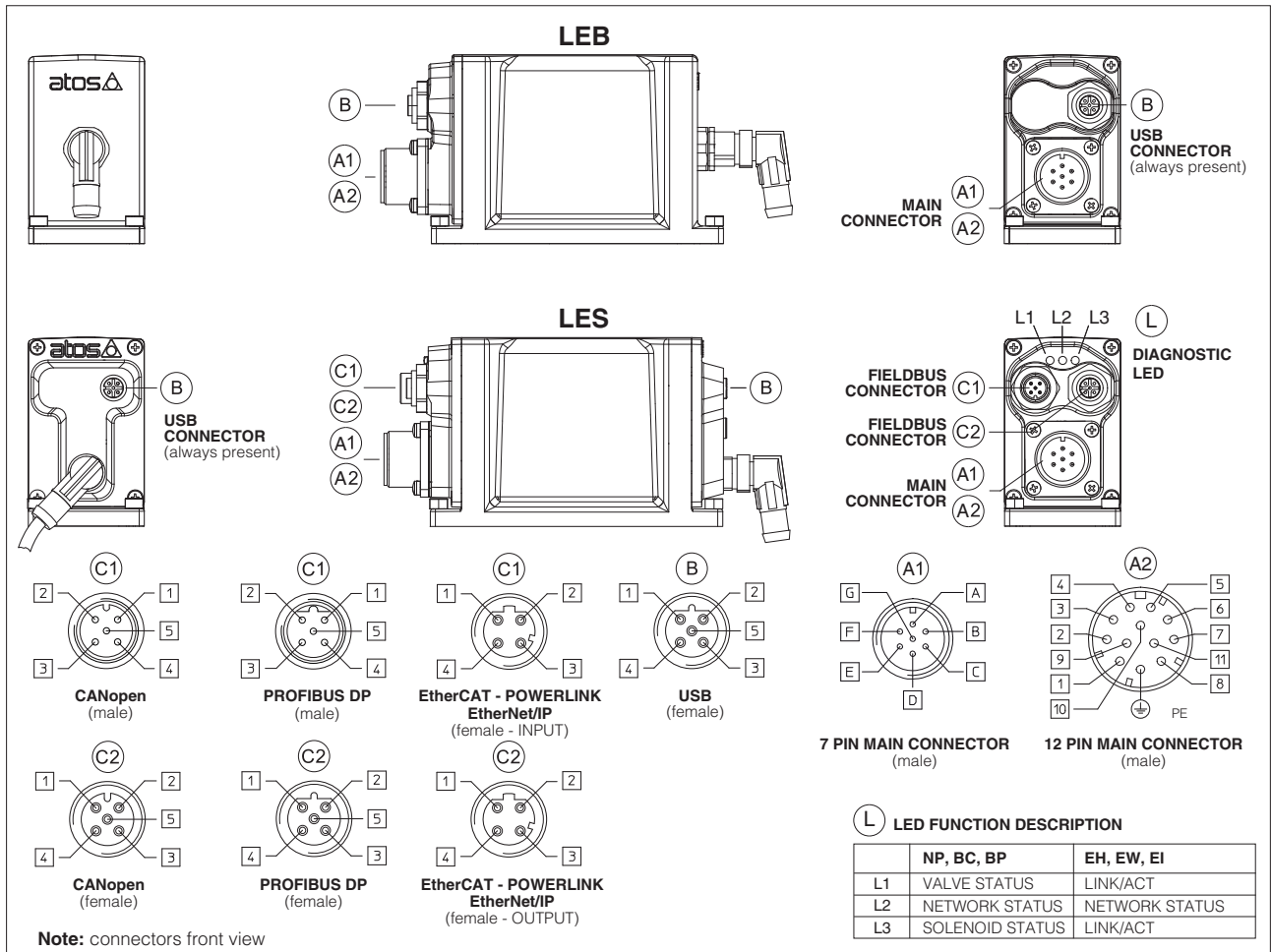

11 CONNECTORS

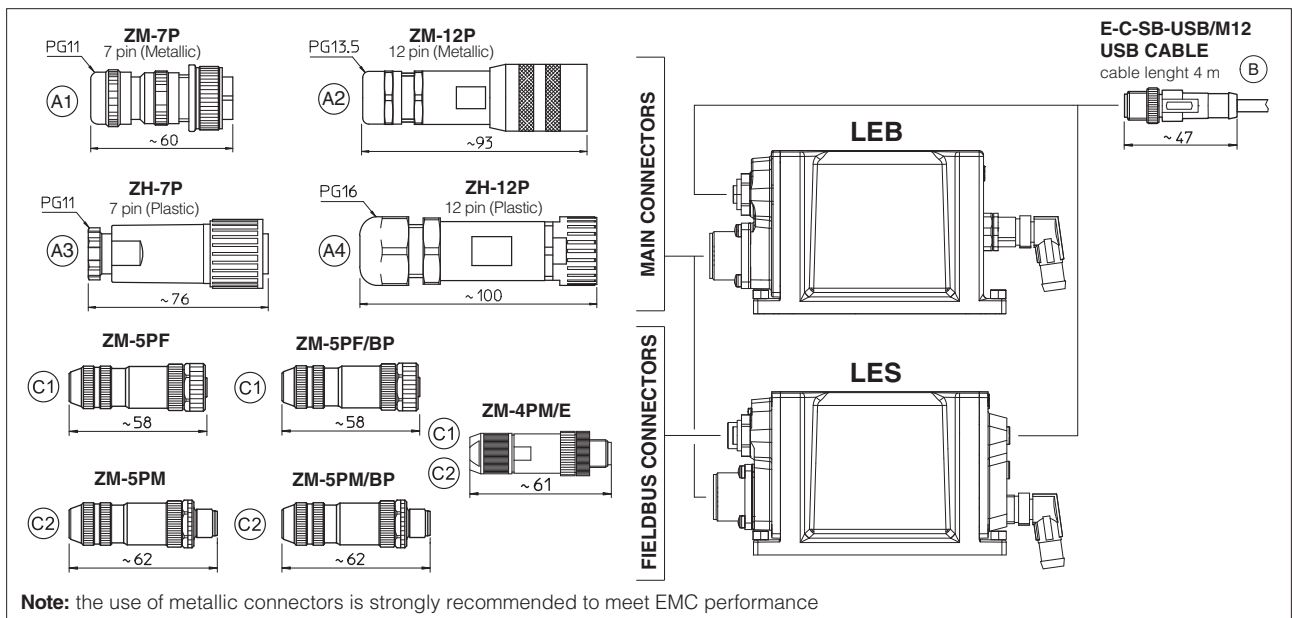

12 MODEL CODES OF MAIN CONNECTORS AND COMMUNICATION CONNECTORS - to be ordered separately

VALVE VERSION	LEB LES	LEB /Z LES /Z	BC - CANopen	BP - PROFIBUS DP	EH - EtherCat EW - POWERLINK EI - EtherNet/IP
CONNECTOR CODE	ZM-7P (A1)	ZM-12P (A2)	ZM-5PF (C1)	ZM-5PF/BP (C1)	ZM-4PM/E (C1)
	ZH-7P (A3)	ZH-12P (A4)	ZM-5PM (C2)	ZM-5PM/BP (C2)	ZM-4PM/E (C2)
PROTECTION DEGREE	IP67				
DATA SHEET	GS208, GS210, K500				

only for LES

13 VALVE SETTINGS AND PROGRAMMING TOOLS

Valve's functional parameters and configurations, can be easily set and optimized using Atos E-SW programming software connected via USB port to the digital driver. For fieldbus versions, the software permits valve's parameterization through USB port also if the driver is connected to the central machine unit via fieldbus.

The software is available in different versions according to the driver's options (see table **GS500**):

E-SW-BASIC support: NP (USB) PS (Serial) IR (Infrared)
E-SW-FIELDBUS support: BC (CANopen) BP (PROFIBUS DP) EH (EtherCAT)
 EW (POWERLINK) EI (EtherNet/IP) EP (PROFINET)
E-SW-*/PQ support: valves with SP, SF, SL alternated control (e.g. E-SW-BASIC/PQ)

WARNING: drivers USB port is not isolated! For E-C-SB-USB/M12 cable, the use of isolator adapter is highly recommended for PC protection

WARNING: see tech table **GS500** for the list of countries where the Bluetooth adapter has been approved

USB or Bluetooth connection

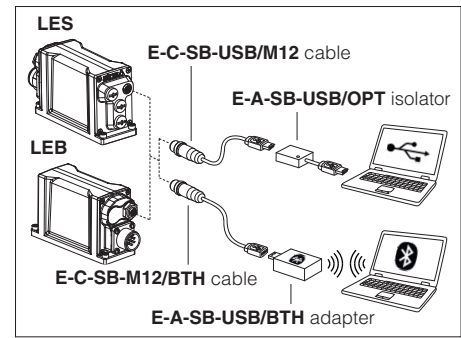

14 FASTENING BOLTS and VALVE MASS

Size	Fastening bolts class 12.9 (1)	Tightening torque	Mass (Kg)
32	N°4 M16x60	300 Nm	12,0
40	N°4 M20x70	600 Nm	17,6
50	N°4 M20x80	600 Nm	25,6

Size	Fastening bolts class 12.9 (1)	Tightening torque	Mass (Kg)
63	N°4 M30x120	2100 Nm	46,5
80	N°8 M24x80	1000 Nm	74,6
100	N°8 M30x120	2100 Nm	128

(1) Fastening bolts supplied with the valve

15 MAIN CONNECTORS INSTALLATION DIMENSIONS

Installation 1 - possible interference between manifold and main connector

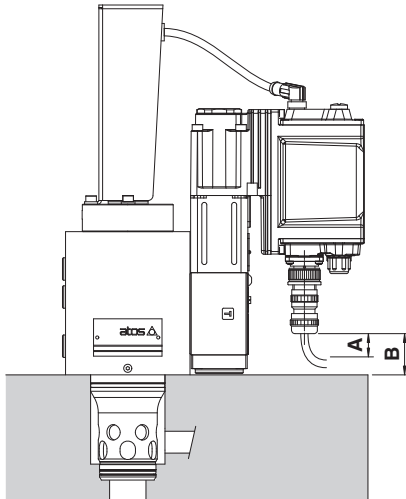

A = 15 mm space to remove the 7 or 12 pin main connectors
B = Clearance between main connector to valve's mounting surface. See the below table to verify eventual interferences, depending to the valve size and connector type

Installation 2 - no interference

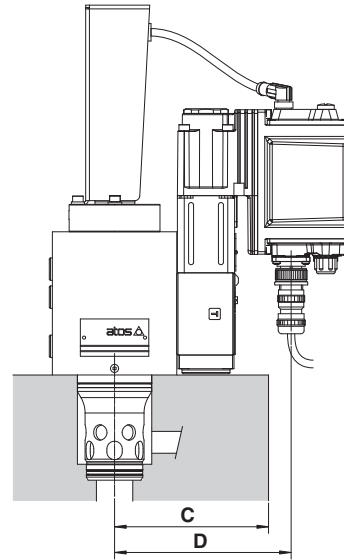

C = Max manifold dimension to avoid interference with the main connector, see below table

Reference dimension	Main connector code	Valve size					
		32	40	50	63	80	100
B	ZM-7P	32	32	45	68	68	80
	ZH-7P	Note 1	Note 1	29	52	52	64
	ZM-12P	Note 1	Note 1	Note 1	35	35	47
	ZH-12P	Note 1	Note 1	Note 1	Note 1	Note 2	40
C (max)	-	121	134	141	172	202	229
D	-	141	154	161	192	222	249

Above dimensions refer to the main connector fully screwed to driver's connector. The space **A** = 15 mm to remove the connector must be considered

Note 1: the connector installation can be performed only if the valve's driver protrudes from the edge of the relevant mounting manifold as represented in above "Installation 2"

Note 2: the connector installation may be critic, depending to the cable size and bending radius

16 INSTALLATION DIMENSIONS [mm]

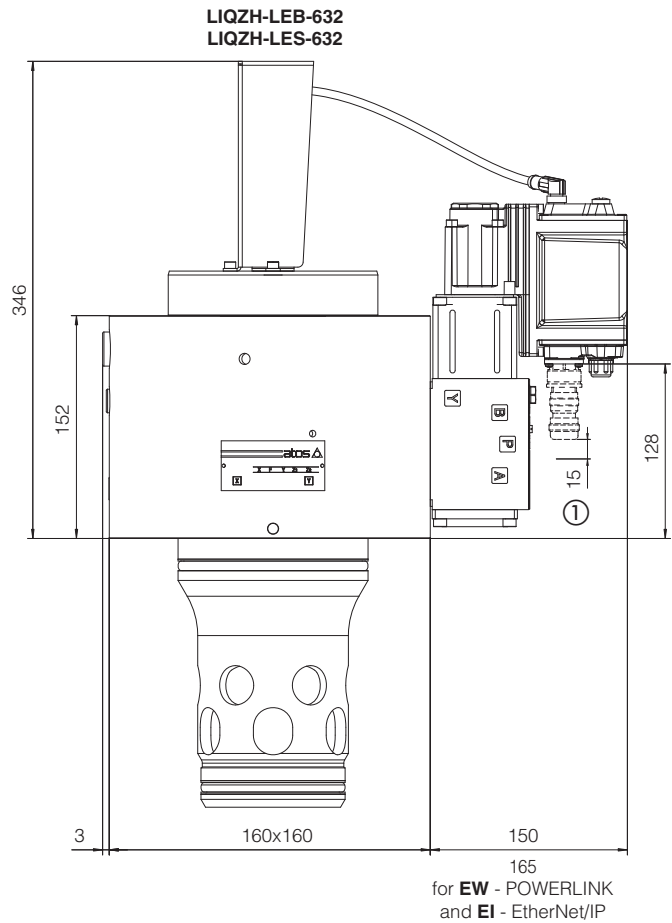
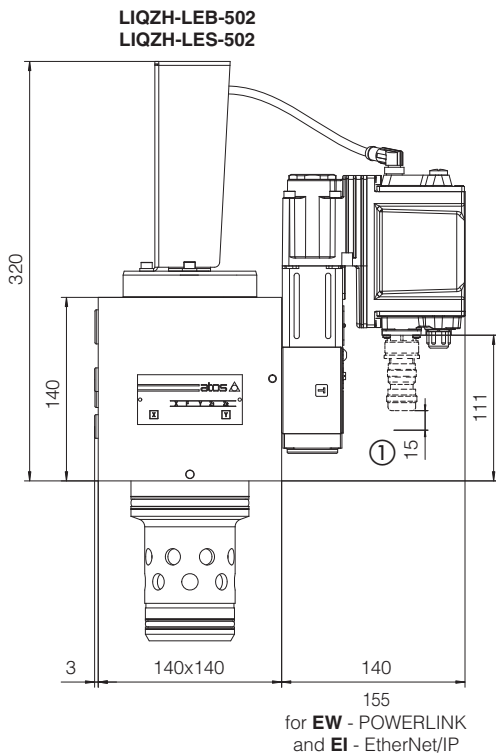
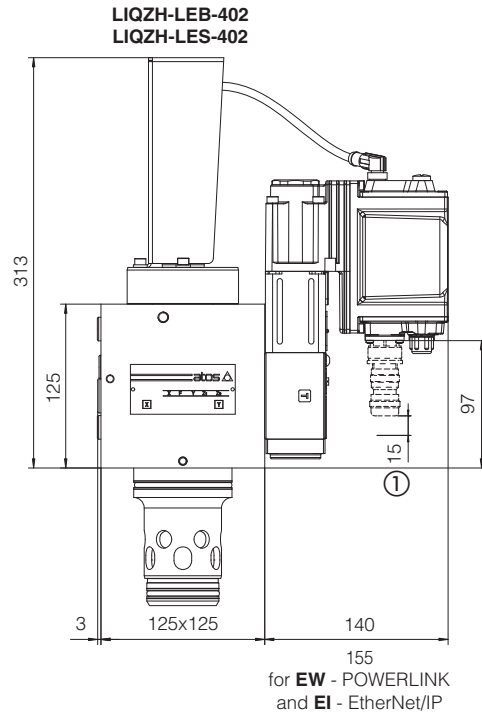
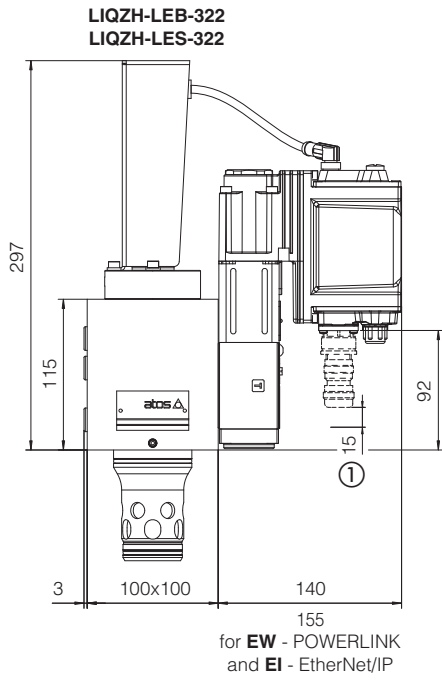

① Space to remove the 7 or 12 pin main connector. For main and communication connectors see section 11, 12

Note: for mounting surface and cavity dimensions, see table P006

LIQZH-LEB-802
LIQZH-LES-802

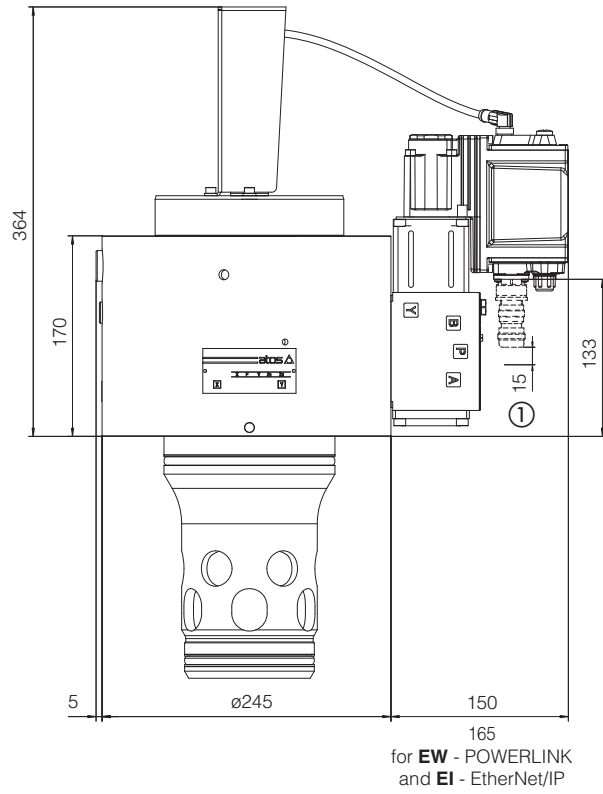

LIQZH-LEB-1002
LIQZH-LES-1002

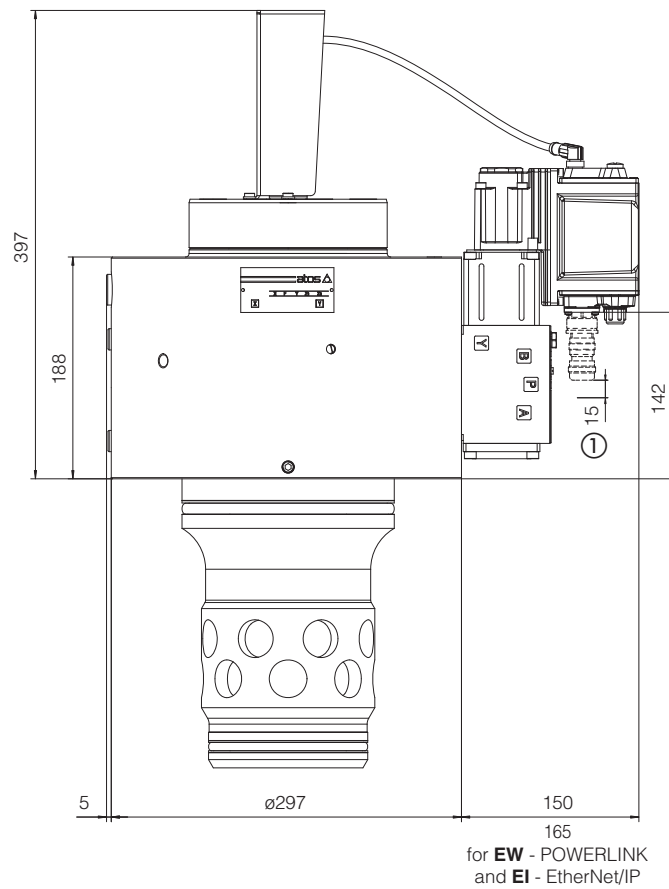

① Space to remove the 7 or 12 pin main connector. For main and communication connectors see section 11, 12

Note: for mounting surface and cavity dimensions, see table P006