

# Operating and maintenance information

for ex-proof cylinders & servocylinders

These operating and maintenance information are valid only for Atos ex-proof cylinders & servocylinders; they are intended to provide useful guidelines to avoid risks when hydraulic cylinders are installed in a machine or a system. Information and notes about transportation and storage of hydraulic cylinders are also provided.

These norms must be strictly observed to avoid damages and ensure trouble-free operation. The respect of these operating and maintenance information ensures an increased working life and thus reduced repairing cost of the hydraulic cylinders and system.

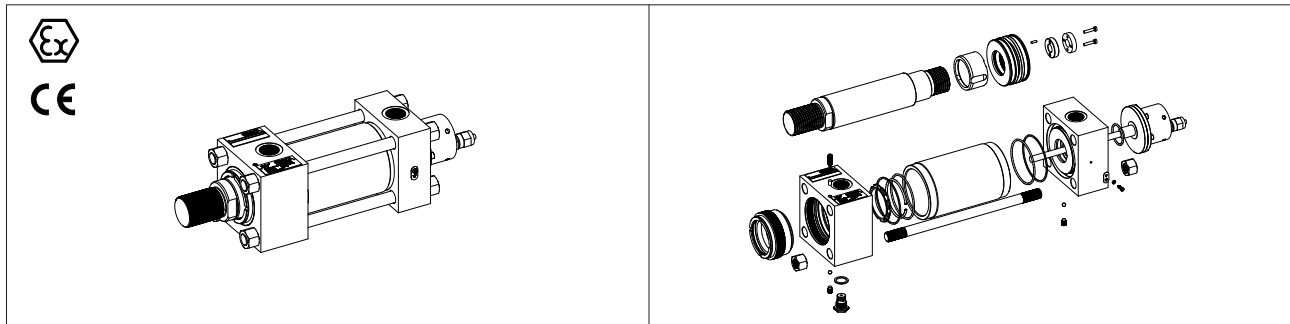

## 1 SYMBOLS CONVENTIONS

This symbol refers to possible danger which can cause serious injuries

## 2 GENERAL NOTES

**The cylinder operating and maintenance information are part of the operating instructions for the complete machine but they cannot replace them**

Atos is not liable for damages resulting from an incorrect observance of these instructions.

All the hydraulic cylinders have 1 year warranty; the expiration of warranty results from the following operations:

- Unauthorised mechanical or electronic interventions
- The hydraulic cylinders are not used exclusively for their intended purpose as defined in these operating and maintenance instructions

## 3 HARMONIZED STANDARDS

CKA cylinders meet the requirements laid down in the Explosion protection directive 2014/34/EU with reference to European standards documentations:

ISO 80079-36 "Non electrical equipment for potentially explosive atmospheres - Basic method and requirements"  
 ISO 80079-37 "Non electrical equipment for explosive atmospheres - Protection constructional safety 'c', liquid immersion 'k'"

The hydraulic cylinder must be exclusively used in areas and zones assigned to the equipment group and category. Also observe the other details about explosion protection given as follow. See section [6](#) for zones in relation to equipment groups and category.

**Check the code in the nameplate to ensure that the hydraulic cylinder is suitable for the installation area**

## 4 WORKING CONDITIONS

**The operation of hydraulic cylinders is not permitted at different operating and environmental conditions than those specified below**

Description	CKA, CKAM
Ambient temperature	-20 ÷ +70°C      -40 ÷ +65°C for <b>CKAM</b>
Fluid temperature	-20 ÷ +70°C ( <b>T6</b> )      -20 ÷ +120°C ( <b>T4</b> ) for seals type <b>G2</b> (1)
Max surface temperature	≤ +85 °C ( <b>T6</b> )      ≤ +135 °C ( <b>T4</b> ) for seals type <b>G2</b> (1)
Max working pressure	16 MPa (160 bar)
Max pressure	25 MPa (250 bar)
Max frequency	5 Hz
Max speed	1 m/s                      0,5 m/s for seals type <b>G1</b>
Recommended viscosity	15 ÷ 100 mm <sup>2</sup> /s
Max fluid contamination level	ISO4406 20/18/15 NAS1638 class 9, see also filter section at <a href="http://www.atos.com">www.atos.com</a> or KTF catalog

**Note:** (1) Cylinders with seals type **G2** may also be certified **T6** limiting the max fluid temperature to 70°C

5 NAMEPLATES

**Nameplate 1 - Standard**



**Nameplate 2 - ATEX**

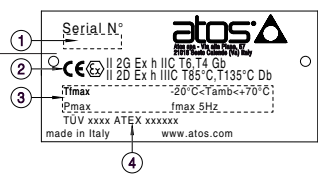

**Nameplate 1 - Standard (2)**

Pos.	Description
①	Delivery date
②	Cylinder code
③	Series number
④	Customer code (only if requested)
⑤	CE mark

**Nameplate 2 - ATEX (1)(2)**

Pos.	Description
①	Cylinder serial number
②	Marking according to ATEX directive
③	Working limit conditions
④	Notified body and certified number

**Working conditions - legend**

Sym.	Meaning
<b>Tfmax</b>	Max fluid temperature
<b>Pmax</b>	Max pressure
<b>Tamb</b>	Ambient temperature
<b>fmax</b>	Max frequency

**Notes:** (1) ATEX cylinders are supplied with 2 nameplates: standard and ATEX  
 (2) The position of the nameplate on the rear or front heads can change due to the cylinder overall dimensions

6 ATEX CERTIFICATION

The user must define the overall areas of the system into different explosive atmospheres zones in accordance with directive EN 60079-10-1/2. The table below shows the available installation zones related to the equipment group and category.

EN 60079-0		Directive 2014/34/EU		Application, properties (exempt from Directives)	Zones EN 60079-10-1/2
EPL	Group	Equipment group	Category		
Gb	II	II	2G	Potentially explosive atmospheres, in which explosive gases, mists or vapors are likely to occur occasionally. <b>High level of protection</b>	1, 2
Gc			3G	Potentially explosive atmospheres, in which explosive gases, mists or vapors are likely to occur for short periods. <b>Normal level of protection</b>	2
Db	III	II	2D	Potentially explosive atmospheres, in which explosive dust/air mixtures are likely to occur occasionally. <b>High level of protection</b>	21,22
Dc			3D	Potentially explosive atmospheres, in which explosive dust/air mixtures are likely to occur rarely or for short periods. <b>Normal level of protection</b>	22

**⚠ The cylinder group and category may change when rod position transducers or proximity sensors are provided, see table below and tab. BX500. For details about certification and safety notes consult the user's guides included in the supply**

Cylinder type	Group	Equipment category	Gas/dust group	Temperature class	Zone	
CKA	II	2 GD	II C/III C	T85°C(T6) / T135°C(T4)	1,2,21,22	
CKA with ex-proof rod position transducer	II	2 G	GAS	II B	T6/T5	1,2
			DUST	II C	T85°C/T100°C	21,22
CKA with ex-proof proximity sensors	II	3 G	II	T4	2	

**II 2G Ex h IIC T6,T4 Gb (gas)      II 2D Ex h IIIC T85°C, T135°C Db (dust)**

**GROUP II, Atex**

- II** = Group II for surface plants
- 2** = High protection (equipment category)
- G** = For gas, vapours
- D** = For dust
- Ex** = Equipment for explosive atmospheres
- IIC** = Gas group
- IIIC** = Dust group
- T85°C/T135°C** = Surface temperature class for dust
- T6/T4** = Surface temperature class for gas
- Gb/Db** = EPL Equipment group

## 7 SAFETY NOTES

### 7.1 General

- The presence of cushioning can lead to a peak of pressure that can reduce the cylinder working life, ensure that the dissipated energy is less than the max value reported in **tab. B015**
- Make sure that the maximum working conditions, shown in section [4], are not exceeded
- Ensure to use hydraulic fluids compatible with the selected sealing system, see **tab. BX500**
- The rod must be handled with care to prevent damages on the surface coating which can deteriorate the sealing system and lead to the corrosion of the basic material
- The mounting screws must be free from shearing stress
- Transverse forces on the rods must always be avoided
- When the cylinder has to drive a rotating structure or where little alignment errors are expected, mounting style with spherical bearing should be used
- Contact surfaces, support elements in tolerance, elastic materials and labels must be covered before painting the cylinder

### 7.2 Proximity sensors

- Proximity sensors are supplied already adjusted, if other regulations are necessary see **tab. BX500** or contact our technical office
- Ensure not to remove the sensor while the cylinder is under pressure
- The connectors must never be plugged or unplugged when the power supply is switched-on

### 7.3 Position measuring system

- Position transducers must never be removed, if not otherwise specified in **tab. BX500**, while the cylinder is under pressure
- Observe the information provided in **tab. BX500** for the electronic connections
- The connectors must never be plugged or unplugged when the power supply is switched-on

### 7.4 Installation

- Consult **tab. P002** for installation, commissioning and maintenance of electrohydraulic system
- The piping have to be dimensioned according to the max pressure and max flow rate required
- All pipes and surfaces must be cleaned from dirt before mounting
- Remove all plug screws and covers before mounting
- Make sure that connections are sealed before giving pressure to the system
- Ensure to not exchange the pipe ports when connecting the cylinders
- Bleed-off the system or the hydraulic cylinder using the proper device, see the technical data sheet for details
- Ensure that the cylinder mounting allow easy of acces for the purpose of maintenance and the adjustment of cushioning
- The max surface temperature indicated in the nameplate must be lower than the following values:
  - GAS - **80% of gas ignition temperature**
  - DUST - max value between **dust layer ignition temperature - 75°C** and **2/3 of dust cloud ignition temperature**
- The ignition temperature of the fluid must be 50°C greater than the maximum surface temperature indicated in the nameplate
- The cylinder must be grounded using the threaded hole on the rear head, evidenced by the nameplate with ground symbol. The hydraulic cylinder must be put at the same electric potential of the machine
- It is responsibility of the user to verify that the maximum inlet fluid temperature does not exceed the value reports in the technical data

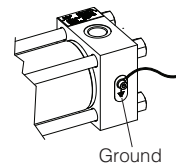

**⚠ For details about ex-proof proximity sensors or position transducer refer to the user's guide included in the supply**

## 8 MAINTENANCE

- Ordinary maintenance of the cylinder consist of cleaning of the external surfaces using a wet cloth to avoid accumulation of dust layer > 5 mm
- Do not use compressed air for cleaning to avoid any dangerous dust dispersion on the surrounding atmosphere
- Any sudden increment in temperature requires immediate stop of the system and inspection of the relevant components

**⚠ Maintenance must be carried out only by qualified personnel with a specific knowledge of hydraulics and electrohydraulics**

### 8.1 Preliminary check and ordinary maintenance

Atos hydraulic cylinders don't require any maintenance after commissioning. Anyway it is recommended to take into account the following remarks:

- Results of maintenance and inspection must be planned and documented
- Check oil escaping from oil ports or leakages at the cylinder heads
- Check for damages of the chromeplated surface of the rod: damages may indicate oil contamination or the presence of excessive transverse load
- Determine lubricating intervals for spherical clevises, trunnion and all parts not self-lubricated
- The rod should always be retracted during long stop of the machine or system

**⚠ Any repairing must be performed only by experienced personnel, authorized by Atos**

- Remove any salt, machining residuals or other dirt cumulated on the rod surface
- Follow the maintenance instructions of the fluid manufacturer

### 8.2 Repairing

Before beginning any repairing observe the following guidelines:

- Unauthorized opening of the cylinder during the warranty period results in the warranty expiration
- Be sure to use only original spare parts manufactured or supplied by Atos
- Provide all the required tools to make the repair operations safely and not damage the components
- Read and follow all the safety notes given in section [7]
- Ensure that the cylinder is well locked before beginning any operation
- Disassembly or assembly the cylinder with the right order as indicated in section **8.3**
- When mounting rod or piston guides and seals observe the correct position as indicated in section **8.4**. Any bad positioning can result in oil leakages
- It is strongly recommended the use of expanding sleeves to insert the seals in the proper groove
- Tighten all the screws or nuts as follow: lubricates the threads, insert the screw or the nut by hand for some turns, tighten the screw crosswise with the tightening torque specified in the technical table (a pneumatic screw driver may be used)
- Rod bearing and piston must be locked respectively to the front head and to the rod by means of special pin to avoid unscrewing
- The replacement of wear parts such as seals, rod bearing and guide rings depends on the operating conditions, temperature and quality of the fluid

### 8.3 Cylinders exploded views

**CKAM servocylinder** - For spare parts contact our technical office

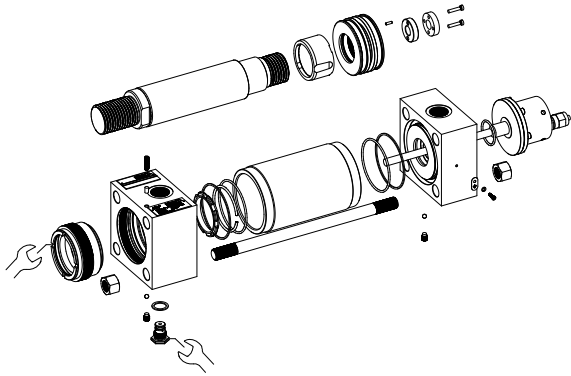

**CKA** - For spare parts contact our technical office

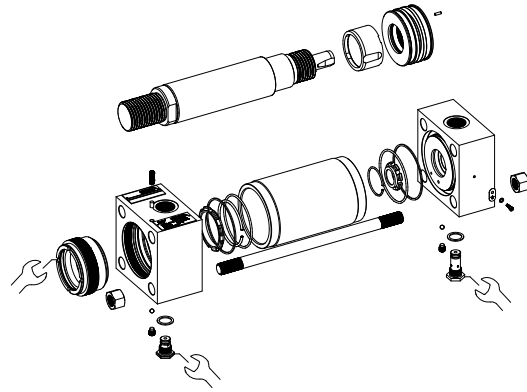

**Note:**  this symbol means that a particular equipment is required for mounting, contact our technical office

### 8.4 Sealing system mounting

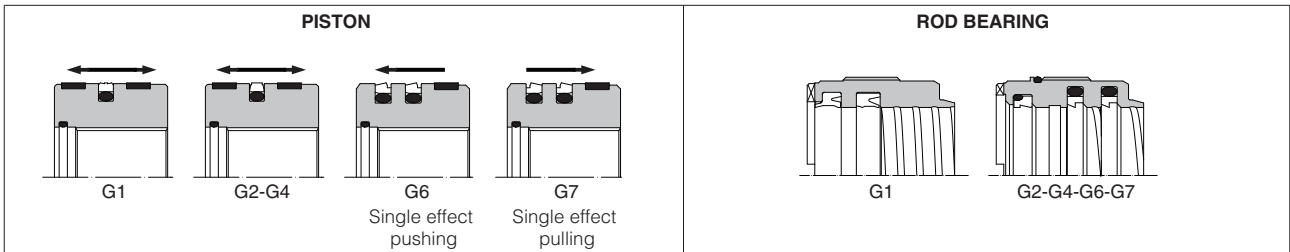

## 9 TRANSPORT AND STORAGE

### 9.1 Transport

Observe the following guidelines for transport of hydraulic cylinders:

- Cylinders have to be transported using a forklift truck or a lifting gear always ensuring a stable position of the cylinder
- Cylinders have to be transported in horizontal position in their original packaging
- Use soft lifting belts to move or lift the cylinders in order to avoid damages
- Before any movement check the cylinders weight (due to tolerances, the weight may be 10% greater than the values specified in the technical table)

 **Additional parts such as pipes, subplates and transducers must never be used for lifting**

### 9.2 Storage

Corrosion protection is achieved with alkyd primer painting RAL 9007: the primer grants a storage period up to 12 months. Additionally all cylinders are tested with mineral oil OSO 46; the oil film, presents in the cylinder chambers after testing, ensures the internal corrosion protection.

Anyway be care to observe the following remarks:

- When a storage in the open air is foreseen ensure that cylinders are well protected against water
- The cylinders must be inspected at least once a year and rotated through 90° every six months to preserve the seals

 **In case of storage period longer than 12 months, contact our technical office**

**10 CYLINDERS TROUBLESHOOTING**

TROUBLE	POSSIBLE CAUSES	SOLUTIONS
<b>Oil leakage</b>	High lateral loads involve a premature wear of the bronze bushing, seals and wear rings	a) Improve the precision of the machine alignment b) Decrease lateral loads c) Install a pivoted mounting style <b>C-D-G-H-S-L</b>
	Fluid contaminants produce scratch and score marks on the seals	Check the fluid contamination class is < 20/18/15
	Chemical attack cause the deterioration of seals compound	Check seals compatibility with operating fluid
	High temperatures (fluid/ambient) the seals dark and flaked	a) Decrease the fluid temperature b) Install <b>G2</b> sealings for high temperatures
	Low temperature (ambient) make the seals brittle	a) Move the cylinder in a higher temperature zone b) Install <b>G9</b> seals for low temperatures
	High rod speed reduce the lubricant capacity of the seals	For rod speed > 0,5 m/s Install <b>G2 – G4</b> seals
	High frequency reduce the lubricant capacity of the seals	For rod frequency > 5 hz Install <b>G0</b> seals
	Output rod speed higher than the input one	Check the rod speed ratio in/out complies with the minimum $R_{min}$ value, see tech.table <b>B015</b>
	The pressurization of the mixture air/mineral oil may involve self combustion dangerous for the seals (Diesel effect)	Bleed off completely the air inside the hydraulic circuit
<b>Wiper or seal extrusion</b>	Overpressure	a) Limit the pressure of the system b) Install <b>G2-G4-G8</b> seals if overpressure cannot be reduced
	Rod seals leakages may involve overpressures among wiper and rod seal, causing their extrusion	a) See possible causes and solutions for oil leakage troubles b) Install draining option <b>L</b>
<b>Lose of cushioning effect</b>	Rod speed too low at end stroke	a) Check the cushioning adjustment is not fully open, regulate it if necessary b) Replace "fast" cushioning <b>1-2-3</b> , with "slow" cushioning <b>4-5-6</b> if the cushioning is not effective with cushioning adjustment fully closed
	Cushioning adjustment cartridge with improper regulation	Close the cushioning adjustment screw till restoring the cushioning effect
	Fluid contaminants produce scratch and score marks on the cushioning piston	Check the fluid contamination class is < 20/18/15
<b>Rod locked or impossible to move</b>	Overpressure in the cushioning chamber could involve the cushioning piston locking	a) Replace "fixed" cushioning <b>7-9</b> with "adjustable" cushioning <b>1-3</b> b) For adjustable cushioning, open the cushioning adjustment to decrease the max pressure inside the cushioning chamber c) Check the energy dissipated by the cushioning is lower than max energy dissipable, see tech.table <b>B015</b>
	Fluid contaminants may lock the piston because of its tight tolerances	Check the fluid contamination class is < 20/18/15
<b>Rod failure</b>	Overload/overpressure involves ductile rod failure	a) Check the overpressure inside the cylinder and decrease it b) Check the compliance with the admitted operating pressure according to the cylinder series
	High load/pressure coupled to high frequencies or long life expectation involves fatigue rod failure	a) Check the expected rod fatigue working life proposed in tech.table <b>B015</b> b) Decrease the operating pressure
<b>Rod vibration</b>	Seals with excessive friction could involve rod vibration and noise	Install low friction PTFE seals <b>G2-G4</b> , see tech.table <b>B015</b>
	Air in the circuit may involve a jerky motion of the rod	Bleed off completely the air inside the hydraulic circuit
<b>Rod motion without oil pressure</b>	Variations in the fluid temperature involve the fluid expansion / compression thus the rod moving	a) Decrease the temperature variations in the oil b) Change the fluid type to decrease the coefficient of thermal expansion
	Excessive oil leakage from the piston or rod seals	See likely causes and solutions for oil leakage troubles
<b>Noisy cylinder</b>	Impact of the piston with the heads caused by high speed ( >0,05 m/s)	a) Decrease the rod speed b) Install external or internal cushioning system <b>1-9</b> , see tech.table <b>B015</b> for the max energy that can be dissipated
	Fluid contaminants, foreign particles inside the cylinder may generate unusual noise	Check the fluid contamination class is < 20/18/15
	High oil flow speed > 6 m/s	a) Increase the piping diameters to reduce the oil flow speed b) Install oversized oil ports, options <b>D-Y</b>

**11 SERVOCYLINDERS TROUBLESHOOTING**

TROUBLE	POSSIBLE CAUSES	SOLUTIONS
<b>Transducer malfunctioning / failure</b>	Improper electronic connections may involve the transducer malfunctioning	Check the electronic connections scheme in tech table <b>B310</b>
	Not stabilized power supply may involve dangerous peak of voltage	Install a voltage stabilizer
	Uncontrolled disconnection and connection of plug-in connectors may damage the transducer	Be careful to switch off the power supply before connecting the position transducer

**Note:** for cylinders troubleshooting refer to section [10](#)