

Intrinsically safe solenoid directional valves

on-off spool type, direct - **ATEX** or **IECEX**

Phase-out component not recommended for new applications

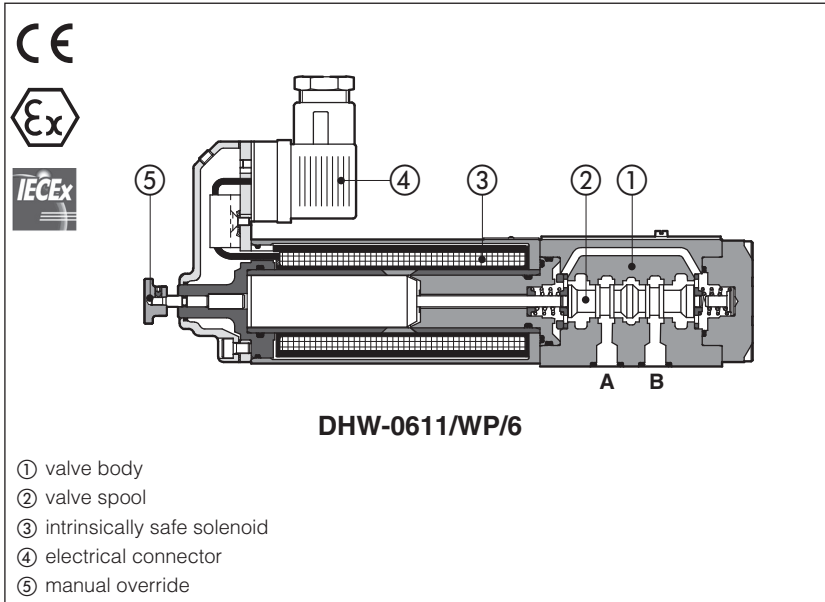

DHW

On-off, spool type, directional valves equipped with intrinsically safe solenoids certified for safe operation in hazardous environment with potentially explosive atmosphere.

Certifications:

- **ATEX** or **IECEX**:
II 1G Ex ia IIC, IIB, IIA
surface plants zone 0, 1 and 2

- **ATEX** or **IECEX**:
IM2 Ex ia IMb, Ex ib IMb
surface, tunnels or mining plants

DHW are **SIL** compliance with IEC 61508

See section 7 for certification data

The valves must be electrically powered through specific "safety barriers" limiting the max current to the solenoid, see section 13

Size: **06**

Max flow: up to **25 l/min**

Max pressure: **350 bar**

1 MODEL CODE

DHW	/	*	-	0	71	3H	/	*	/	6	*	/	*
Intrinsically safe valve, spool type, direct													
Certification type: - = Omit for Atex Group II M = Atex Group I (mining) IE = IECEX Group II IEM = IECEX Group I (mining)													
Valve size (ISO 4401): 0 = size 06													
Configuration , see section 2 :													
Spool type , see section 2 :													
Seals material , see section 6 : - = NBR PE = FKM BT = HNBR (1)													
Series number													
Connector type 6 = DIN 43650 (standard)													
Options (2): A = solenoid at side of port B WP = prolonged manual override													

(1) Not for certification **M** and **IEM**, Group I (mining)

(2) Possible combined options: all combinations are available

 The pressure at T port makes difficult the manual override operation that can be possible only if its value is lower than 50 bar

2 CONFIGURATION and SPOOLS (representation according to ISO 1219-1)

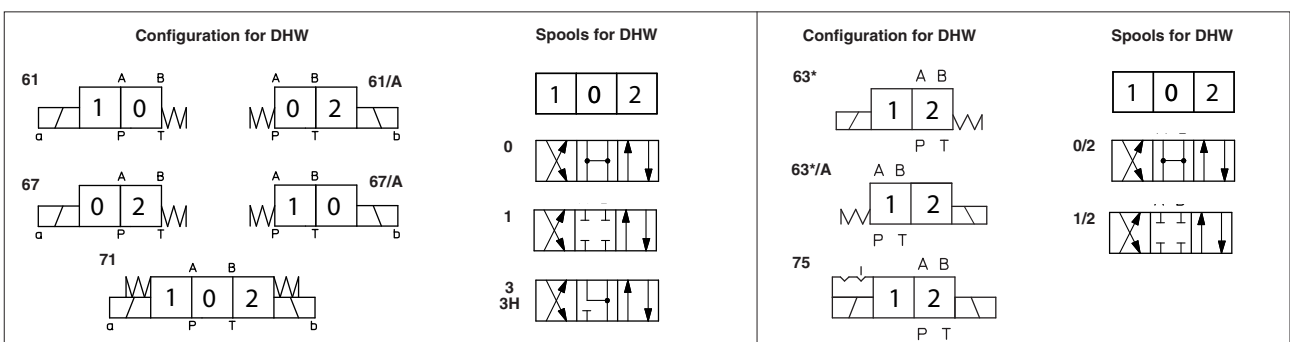

Note: Spool type 3H is available only for configuration 71. It is similar to spool type 3 but with higher flow capability A-B → T in central position, see section 10

3 GENERAL CHARACTERISTICS

Assembly position / location	Horizontal position only
Subplate surface finishing to ISO 4401	Acceptable roughness index, Ra ≤0,8 recommended Ra 0,4 - flatness ratio 0,01/100)
MTTFd values according to EN ISO 13849	150 years, for further details see technical table P007
Ambient temperature	Standard = -20°C ÷ +60°C /PE option = -20°C ÷ +70°C /BT option = -40°C ÷ +70°C
Storage temperature range	Standard = -20°C ÷ +80°C /PE option = -20°C ÷ +80°C /BT option = -40°C ÷ +70°C
Surface protection	Zinc coating with black passivation - salt spray test (EN ISO 9227) > 200h
Compliance	Intrinsically safe protection "Ex ia", see section 7 RoHs Directive 2011/65/EU as last update by 2015/65/EU REACH Regulation (EC) n°1907/2006

4 HYDRAULIC CHARACTERISTICS

Operating pressure	Ports P,A,B: 350 bar; Port T 160 bar
Rated flow	See Q/Δp diagrams at section 10
Maximum flow	25 l/min , see operating limits at section 11

5 ELECTRICAL CHARACTERISTICS - see also section 7

Nominal resistance at 20°C	150 Ω
Coil insulation	Class H
Working voltage	12 ÷ 26 V
Minimum supply current	65mA, from I.S. barriers
Protection degree	IP66
Duty factor	100%
Electrical connector	DIN 43650 2 pin+GND

6 SEALS AND HYDRAULIC FLUIDS - for other fluids not included in below table, consult our technical office

Seals, recommended fluid temperature	NBR seals (standard) = -20°C ÷ +60°C, with HFC hydraulic fluids = -20°C ÷ +50°C FKM seals (/PE option) = -20°C ÷ +80°C HNBR seals (/BT option) = -40°C ÷ +60°C, with HFC hydraulic fluids = -40°C ÷ +50°C		
Recommended viscosity	15 ÷ 100 mm ² /s - max allowed range 2.8 ÷ 500 mm ² /s		
Max fluid contamination level	ISO 4406 class 20/18/15 NAS 1638 class 9, see also filter section at www.atos.com or KTF catalog		
Hydraulic fluid	Suitable seals type	Classification	Ref. Standard
Mineral oils	NBR, FKM, HNBR	HL, HLP, HLPD, HVLP, HVLDP	DIN 51524
Flame resistant without water	FKM	HFDU, HFDR	ISO 12922
Flame resistant with water	NBR, HNBR	HFC	

⚠ The ignition temperature of the hydraulic fluid must be 50°C higher than the max solenoid surface temperature

(1) Performance limitations in case of flame resistant fluids with water:

-max operating pressure = 210 bar -max fluid temperature = 50°C

7 CERTIFICATION DATA

Valve type	DHW		DHW/IE		DHW/M		DHW/IEM					
Certification	ATEX (Group II)		IECEX (Group II)		ATEX (mining) (Group I)		IECEX (mining) (Group I)					
Solenoid code	OW-18/6		OWI-18/6		OWM-18/6		OWIM-18/6					
Type examination certificate (1)	CESI 02 ATEX 013		IECEX CES 12.0017		CESI 02 ATEX 013		IECEX CES 12.0017					
Method of protection	Ex II 1G		Ex ia		Ex I M2		Ex ia I Mb		Ex ib I Mb			
	IIA T5 Ga	IIB T6 Ga	IIC T6 Ga									
Electrical characteristics (max values)	Ui [V]	28	28	27	19,5	19,11	28	28	27	19,5	19,11	12,4
	Ii [mA]	396	250	130	360	360	396	250	130	360	360	2200
	Pi [W]	2,8	1,8	0,9	1,64	1,72	2,8	1,8	0,9	1,64	1,72	6,82
	Ci , Li	≅ 0		≅ 0		≅ 0		≅ 0		≅ 0		
Temperature class	T5		T6									
Surface temperature (ambient temp. +60°C)	≤ 100°C		≤ 85°C								≤ 150°C	
Ambient temperature	-20 ÷ +60°C		-40 ÷ +60°C (2)								-20 ÷ +60°C	
Applicable standards	EN 60079-0 EN 60079-11 EN 60079-26		IEC 60079-0 IEC 60079-11 IEC 60079-26									

(1) The type examiner certificates can be downloaded from www.atos.com (2) Only for /BT option

⚠ **WARNING: service work performed on the valve by the end users or not qualified personnel invalidates the certification**

8 SIL compliance with IEC 61508: 2010

- **SC3** (systematic capability)
- max **SIL 2** (HFT = 0 if the hydraulic system does not provide the redundancy for the specific safety function where the component is applied)
- max **SIL 3** (HFT = 1 if the hydraulic system provides the redundancy for the specific safety function where the component is applied)

9 EX PROOF SOLENOIDS WIRING

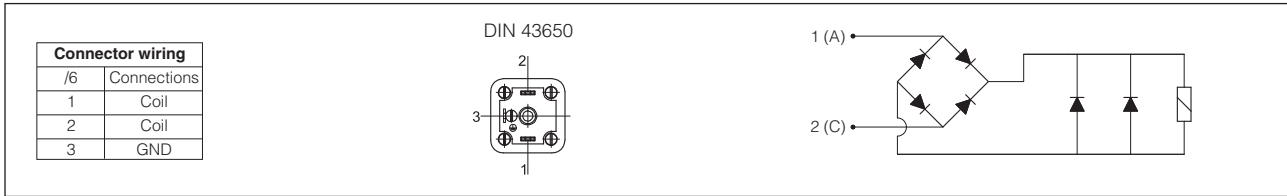

10 Q/Δp DIAGRAMS based on mineral oil ISO VG 46 at 50°C

DHW

spool type	Flow direction					
	0	0/2	1/2	1	3	3H
P→A / P→B	4	5	5	3	3	3
A→T / B→T	6	2	1	2	4	5
A - B→T						4

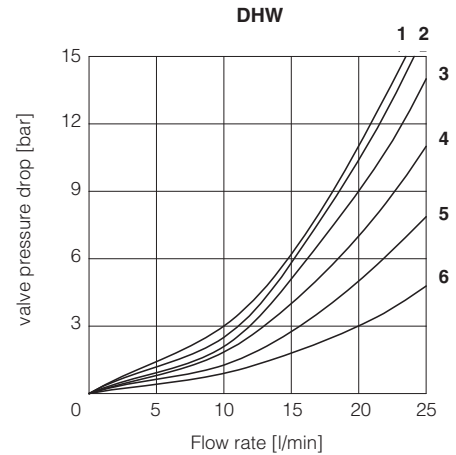

11 OPERATING LIMITS based on mineral oil ISO VG 46 at 50°C

The diagrams refer to warm solenoids and power supply provided by the Atos barrier type **Y-BXNE-412**.
 For DHW valves the curves refer to application with symmetrical flow through the valve (i.e. P→A and B→T).
 In case of asymmetric flow the operating limits must be reduced.

DHW type	0	0/2	1/2	1	3	3H
Diagram	B	B	C	C	A	D

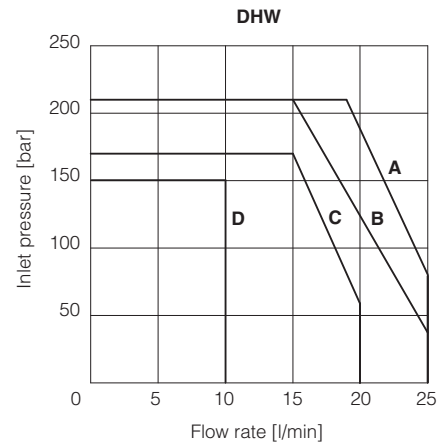

12 INTERNAL LEAKAGES

DHW internal leakages based on mineral oil ISO VG 46 at 50°C
18 cm³/min with P=100 bar - fluid viscosity = 43 cSt at 40 °C
30 cm³/min with P=140 bar - fluid viscosity = 22 cSt at 45 °C

13 INTRINSICALLY SAFE BARRIERS - see tech. table **GX010**

Intrinsically safe valves must be powered through safety barriers certified according to Ex-ie protection mode, limiting the energy to the solenoid.

To select the proper intrinsically safe barriers following data must be considered:

- 1) Vmax and Imax of the solenoid as specified in section [7] must not be exceeded also in fault conditions;
- 2) the resistance of the solenoid is 150 Ω and the current supplied by the barrier, in normal operation condition, must be over the min. limit (65 mA) to ensure the valve correct operation (over 70 mA for max performances).

The barriers type **Y-BXNE 412** are galvanically isolated electronic devices, complying with European Norms EN60079-0/06, EN60079-11/07 and ATEX certified according to protection mode Ex ia IIC.

These barriers ensure the optimized functioning of the Atos valves up to the max operating limits specified in section [4].

The barriers Y-BXNE-412 are double channel type, suitable to operate valves with double or single solenoid. Two single solenoid valves can be connected to the barrier (one to each channel) but they cannot be contemporary operated.

MODEL CODE OF I.S. BARRIER

Y-BXNE 412 00	*
Supply voltage	
E = 110/230 VAC	
2 = 24÷48 VDC	

14 INSTALLATION DIMENSIONS [mm]

ISO 4401: 2005 (see table P005)

Mounting surface: 4401-03-02-0-05

Fastening bolts: 4 socket head screws:

M5x50 class 12.9

Tightening torque = 8 Nm

Seals: 4 OR 108

Ports P,A,B,T: $\varnothing = 7.5$ mm (max)

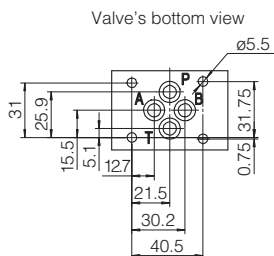

- P** = PRESSURE PORT
- A, B** = USE PORT
- T** = TANK PORT

Mass [kg]	
DHW-06	2,4
DHW-06*/A	2,4
DHW-07*	4

DHW-06

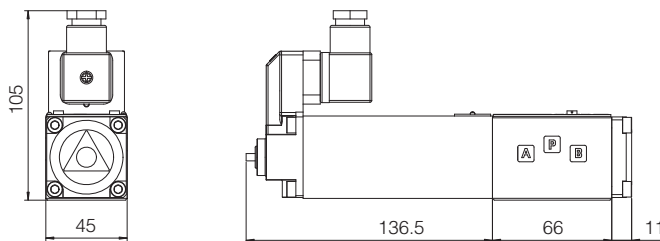

DHW-06*/A

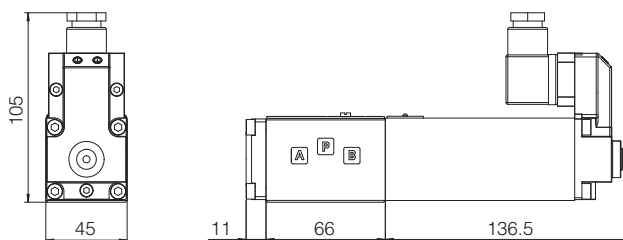

DHW-07*

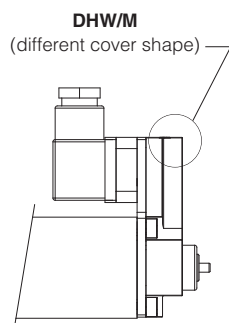
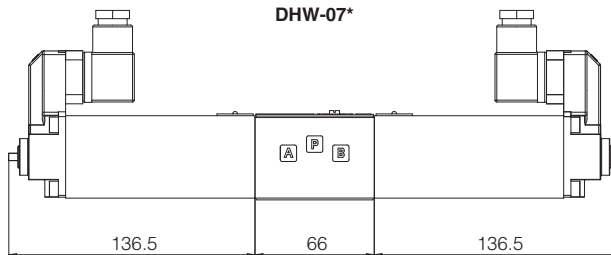

Option /WP

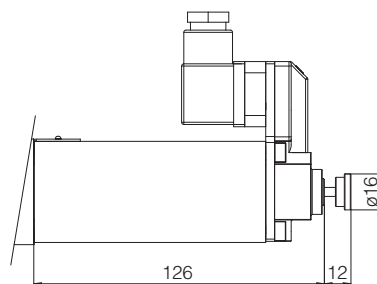

Note: the connector is supplied with the valve

15 RELATED DOCUMENTATION

- X010** Basics for electrohydraulics in hazardous environments
- X050** Summary of Atos intrinsically safe components certified to ATEX, IECEx
- EX950** Operating and maintenance information for intrinsically safe valves
- P005** Mounting surfaces for electrohydraulic valves