

# Servoproportional 3-way cartridges

piloted, with two LVDT transducers, sizes from 25 to 80

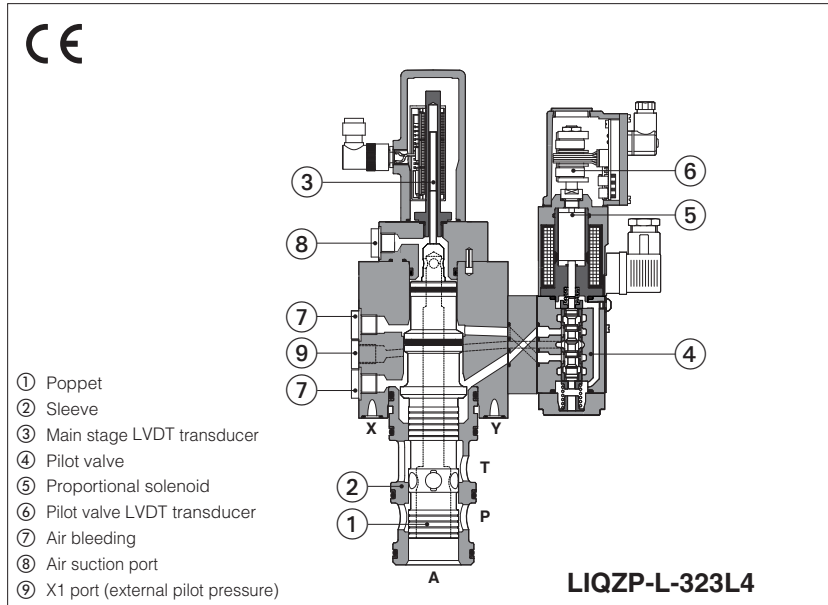

## LIQZP-L

Servoproportional 3-way cartridge valves specifically designed for high speed closed loop controls.

The valves operate in association with digital off-board divers, see section 2.

The two LVDT transducers (pilot and main stage) grant very high regulation accuracy and response sensitivity.

The cartridge execution for blocks installation grants high flow capabilities and minimized pressure drops.

Spool regulation characteristics: L = linear

Size: **25 ÷ 80** - ISO 7368

Max flow: **500 ÷ 5000 l/min**

Max pressure: **420 bar**

### 1 MODEL CODE

<b>LIQZP</b>	-	<b>L</b>	-	<b>25</b>	<b>3</b>	<b>L4</b>	/	<b>*</b>	/	<b>*</b>	/	<b>*</b>
--------------	---	----------	---	-----------	----------	-----------	---	----------	---	----------	---	----------

Servoproportional 3-way cartridge, piloted

**L** = two LVDT transducers

Valve size, see section 4 :

<b>size</b>	<b>25</b>	<b>32</b>	<b>40</b>
l/min	185	330	420
<b>size</b>	<b>50</b>	<b>63</b>	<b>80</b>
l/min	780	1250	2100

Nominal flow (l/min) at Δp 5 bar

**Configuration: 3 = 3 way**

functional symbol: **Standard**

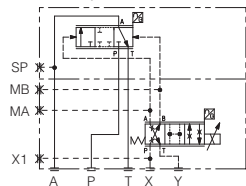

option **/A**

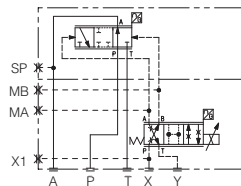

simplified symbol: **Standard**

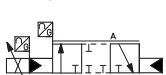

option **/A**

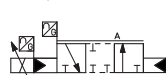

**Seals material,** see section 6 :

- = NBR

**PE** = FKM

**BT** = NBR low temperature

Series number

**Hydraulic options:**

**A** = reversal hydraulic configuration of main spool:  
P-A in rest position

**Spool type, regulating characteristics:**

**L4** = linear



## 2 OFF-BOARD ELECTRONIC DRIVERS

Please include in the driver order also the complete code of the connected proportional valve.

Drivers model	E-BM-LEB	E-BM-LES
Type	digital	digital
Format	DIN-rail panel	DIN-rail panel
Tech table	GS230	GS240



### WARNING

To avoid overheating and possible damage of the electronic driver, the valves must be never energized without hydraulic supply to the pilot stage. In case of prolonged pauses of the valve operation during the machine cycle, it is always advisable to disable the driver.

## 3 GENERAL CHARACTERISTICS

Assembly position	Any position
Subplate surface finishing to ISO 4401	Acceptable roughness index: Ra ≤0,8, recommended Ra 0,4 – Flatness ratio 0,01/100
MTTFd valves according to EN ISO 13849	75 years, for further details see technical table P007
Ambient temperature range	<b>Standard</b> = -20°C ÷ +60°C <b>/PE option</b> = -20°C ÷ +60°C <b>/BT option</b> = -40°C ÷ +60°C
Storage temperature range	<b>Standard</b> = -20°C ÷ +70°C <b>/PE option</b> = -20°C ÷ +70°C <b>/BT option</b> = -40°C ÷ +70°C
Surface protection	Zinc coating with black passivation, galvanic treatment (driver housing)
Corrosion resistance	Salt spray test (EN ISO 9227) > 200 h
Vibration resistance	See technical table G004
Compliance	CE according to EMC directive 2014/30/EU (Immunity: EN 61000-6-2; Emission: EN 61000-6-3) RoHS Directive 2011/65/EU as last update by 2015/863/EU REACH Regulation (EC) n°1907/2006

## 4 HYDRAULIC CHARACTERISTICS - based on mineral oil ISO VG 46 at 50 °C

Size	25	32	40	50	63	80
Nominal flow $\Delta p$ P-A or A-T [l/min]						
$\Delta p = 5$ bar	185	330	420	780	1250	2100
$\Delta p = 10$ bar	260	470	590	1100	1750	3000
Max permissible flow	500	850	1050	2000	3100	5000
Max pressure [bar]	Ports P, A, T = <b>420</b> X = 350    Y ≤ 10					
Nominal flow of pilot valve at $\Delta p = 70$ bar [l/min]	4	8	28	40	100	100
Leakage of pilot valve at P = 100 bar [l/min]	0,2	0,2	0,5	0,7	0,7	0,7
Piloting pressure [bar]	min: 40% of system pressure    max 350    recommended 140 ÷ 160					
Piloting volume [cm <sup>3</sup> ]	2,16	7,2	8,9	17,7	33,8	42,7
Piloting flow <b>(1)</b> [l/min]	6,5	20	25	43	68	76
Response time 0 ÷ 100% step signal <b>(2)</b> [ms]	21	22	22	25	30	34
Hysteresis [% of the max regulation]	≤ 0,1					
Repeatability [% of the max regulation]	± 0,1					
Thermal drift	zero point displacement < 1% at $\Delta T = 40^\circ C$					

**(1)** With step reference input 0÷100%

**(2)** With pilot pressure = 140 bar, see detailed diagrams in section 7.2



### WARNING

The loss of the pilot pressure causes the undefined position of the main spool.

The sudden interruption of the power supply during the valve operation causes the immediate main spool opening A → T or P → A (for option /A). This could cause pressure surges in the hydraulic system or high decelerations which may lead to machine damages.

## 5 ELECTRICAL CHARACTERISTICS

Max power consumption	30 W
Max. solenoid current	2,6 A
Coil resistance R at 20°C	3 ÷ 3,3 $\Omega$
Insulation class	H (180°) Due to the occurring surface temperatures of the solenoid coils, the European standards ISO 13732-1 and EN982 must be taken into account
Protection degree to DIN EN60529	IP65 with mating connectors
Duty factor	Continuous rating (ED=100%)

**6 SEALS AND HYDRAULIC FLUIDS** - for other fluids not included in below table, consult our technical office

Seals, recommended fluid temperature	NBR seals (standard) = -20°C ÷ +60°C, with HFC hydraulic fluids = -20°C ÷ +50°C FKM seals (/PE option) = -20°C ÷ +80°C NBR low temp. seals (/BT option) = -40°C ÷ +60°C, with HFC hydraulic fluids = -20°C ÷ +50°C		
Recommended viscosity	20 ÷ 100 mm <sup>2</sup> /s - max allowed range 15 ÷ 380 mm <sup>2</sup> /s		
Max fluid contamination level	normal operation	ISO4406 class 18/16/13	NAS1638 class 7
	longer life	ISO4406 class 16/14/11	NAS1638 class 5
		see also filter section at <a href="http://www.atos.com">www.atos.com</a> or KTF catalog	
<b>Hydraulic fluid</b>	<b>Suitable seals type</b>	<b>Classification</b>	<b>Ref. Standard</b>
Mineral oils	NBR, FKM, NBR low temp.	HL, HLP, HLPD, HVLP, HVLPD	DIN 51524
Flame resistant without water	FKM	HFDU, HFDR	ISO 12922
Flame resistant with water	NBR, NBR low temp.	HFC	

**7 DIAGRAMS** (based on mineral oil ISO VG 46 at 50 °C)

**10.1 Regulation diagrams, see note**

**1** = LIQZP (all sizes)

Hydraulic configuration vs. reference signal:

	standard	option /A
Reference signal 0 ÷ +10 V } P → A		A → T
12 ÷ 20 mA } P → A		A → T
Reference signal 0 ÷ -10 V } A → T		P → A
4 ÷ 12 mA } A → T		P → A

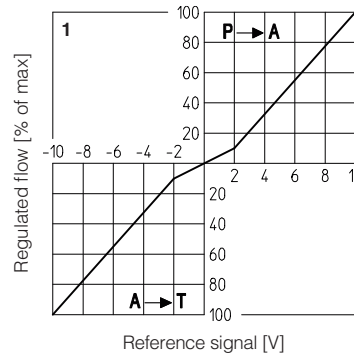

**7.2 Response time**

The response times in below diagrams are measured at different steps of the reference input signal. They have to be considered as average values. For the valves with digital electronics the dynamics performances can be optimized by setting the internal software parameters.

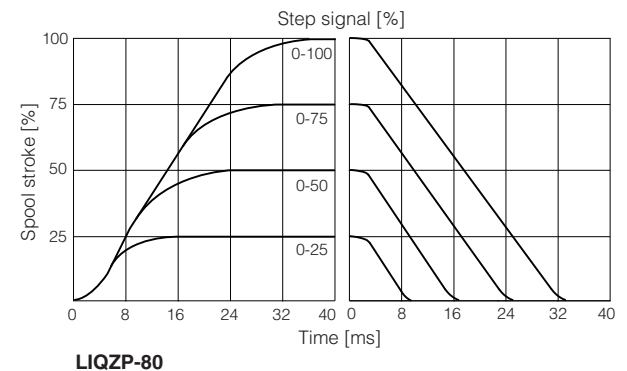
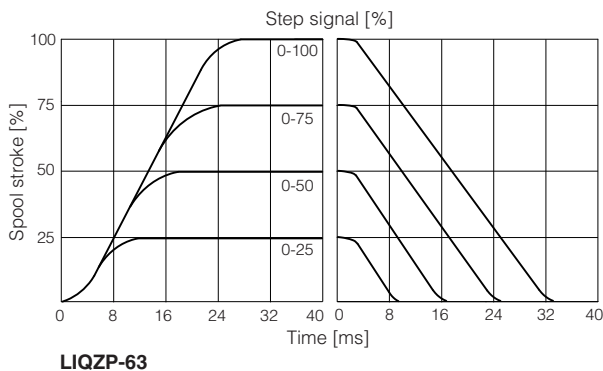
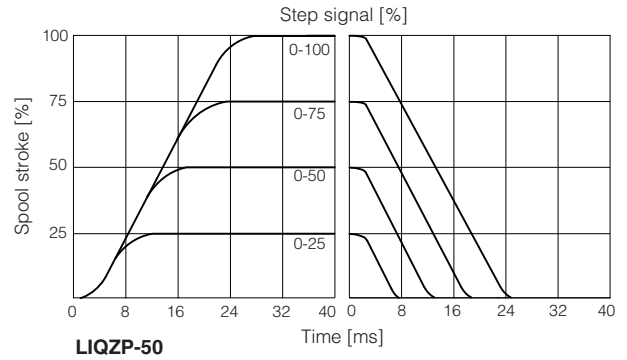
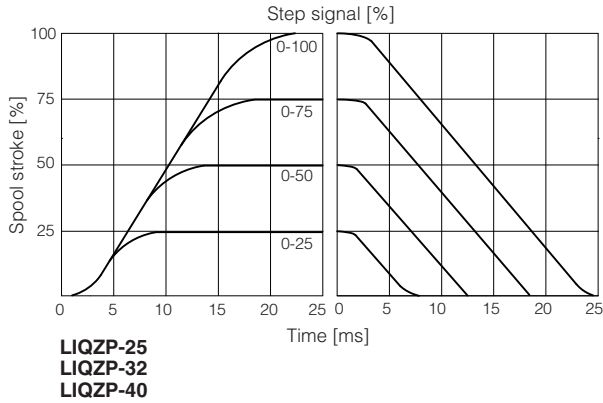

### 7.3 Pressure gain diagram

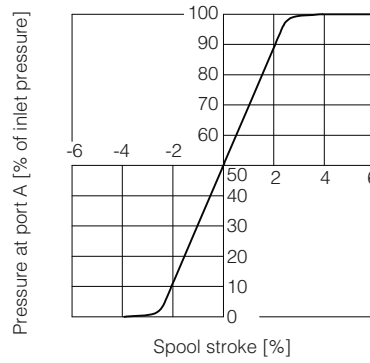
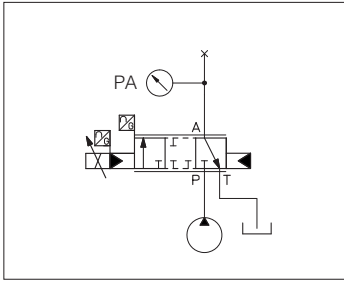

### 7.4 Bode diagrams

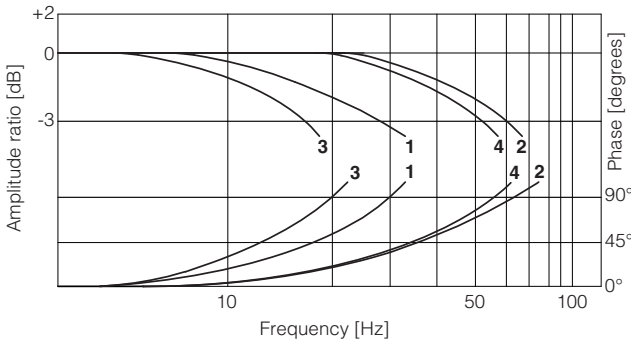

- 1 = LIQZP-L-253L4:  $\pm 90\%$
- 2 = LIQZP-L-253L4:  $\pm 5\%$
- 3 = LIQZP-L-323L4:  $\pm 90\%$
- 4 = LIQZP-L-323L4:  $\pm 5\%$

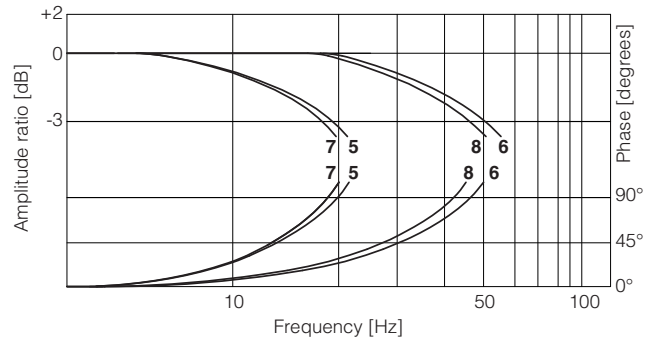

- 5 = LIQZP-L-403L4:  $\pm 90\%$
- 6 = LIQZP-L-403L4:  $\pm 5\%$
- 7 = LIQZP-L-503L4:  $\pm 90\%$
- 8 = LIQZP-L-503L4:  $\pm 5\%$

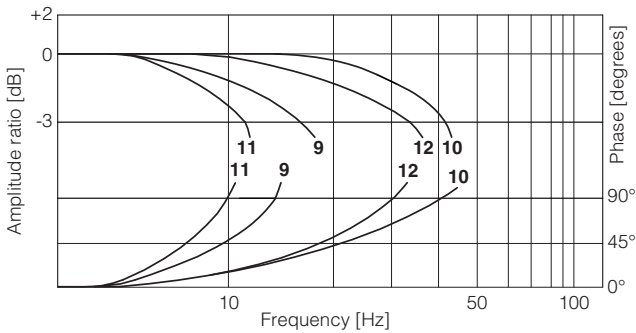

- 9 = LIQZP-L-633L4:  $\pm 90\%$
- 10 = LIQZP-L-633L4:  $\pm 5\%$
- 11 = LIQZP-L-803L4:  $\pm 90\%$
- 12 = LIQZP-L-803L4:  $\pm 5\%$

## 8 HYDRAULIC OPTIONS

**A** = The standard valve version provides the hydraulic configuration A-T of main spool in absence of electric power supply to the valve.

The option /A provides the reverse configuration P-A of main spool in absence of electric power supply to the valve.

This execution is particularly requested in vertical presses for safety reasons, because in case of electric power breakdown the P-A configuration of the main spool prevents the uncontrolled and dangerous downstroke of the press ram.

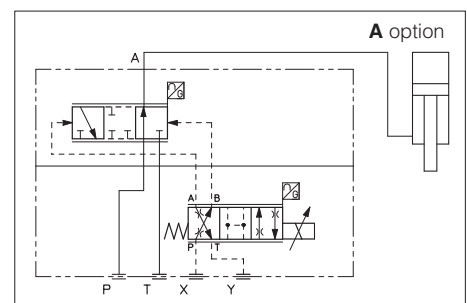

**9 ELECTRICAL CONNECTION** - connectors supplied with the valve

**9.1 Solenoid connector**

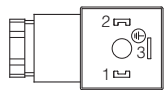
PIN	SIGNAL	TECHNICAL SPECIFICATION	Connector code 666
1	COIL	Power supply	
2	COIL	Power supply	
3	GND	Ground	

**9.2 LVDT pilot transducer connector**

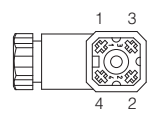
PIN	SIGNAL	TECHNICAL SPECIFICATION	Connector code 345
1	TR	Output signal	
2	VT-	Power supply -15Vdc	
3	VT+	Power supply +15Vdc	
4	GND	Ground	

**9.3 LVDT main stage transducer connector**

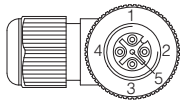
PIN	SIGNAL	TECHNICAL SPECIFICATION	Connector code ZBE-08
1	PROG	Do not connect	
2	VT+	Power supply +15Vdc	
3	AGND	Ground	
4	TR	Output signal	
5	VT-	Power supply -15Vdc	

**10 AIR BLEEDING**

**Size 25**

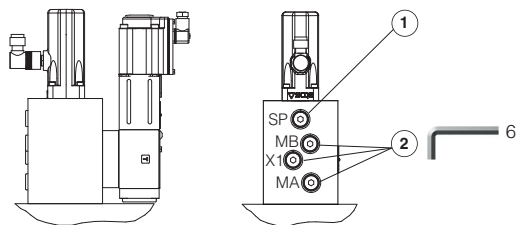

**Size 32 to 50**

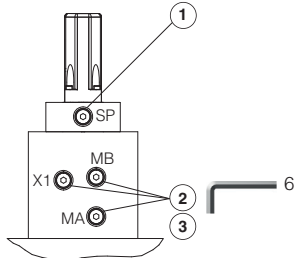

**Size 63 and 80**

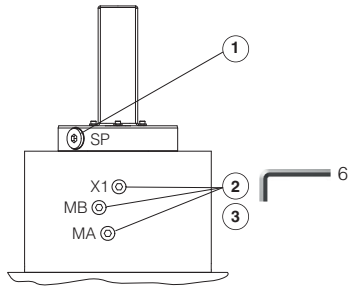

**1 Plugged port - do not open**

**2 Air bleeding (MA, MB):**  
 N° 2 plugs G1/4"  
 At the machine commissioning it is advisable to bleed the air from piloting chambers, by loosening the 2 plugs shown in the picture.  
 Operate the valve for few seconds at low pressure and then lock the plugs.

**3 External pilot pressure (X1):**  
 N° 1 plug G1/4"

**11 FASTENING BOLTS AND VALVE MASS**

Type	Size	Fastening bolts (1)	Mass [kg]
LIQZP	25	4 socket head screws M12x100 class 12.9 Tightening torque = 125 Nm	8,8
	32	4 socket head screws M16x60 class 12.9 Tightening torque = 300 Nm	11,2
	40	4 socket head screws M20x70 class 12.9 Tightening torque = 600 Nm	17,3
	50	4 socket head screws M20x80 class 12.9 Tightening torque = 600 Nm	24,6
	63	4 socket head screws M30x120 class 12.9 Tightening torque = 2100 Nm	44,6
	80	8 socket head screws M24x80 class 12.9 Tightening torque = 1000 Nm	72,2

(1) Fastening bolts supplied with the valve

LIQZP-L-253

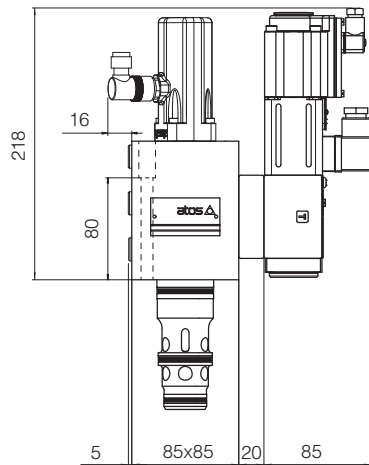

LIQZP-L-323

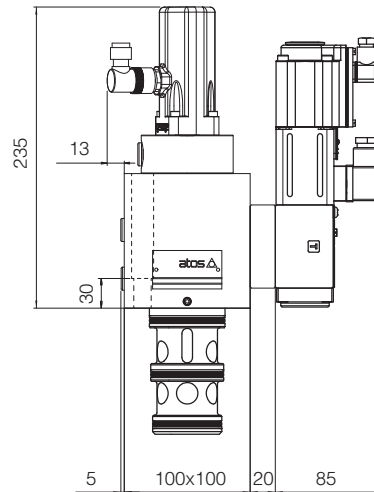

LIQZP-L-403

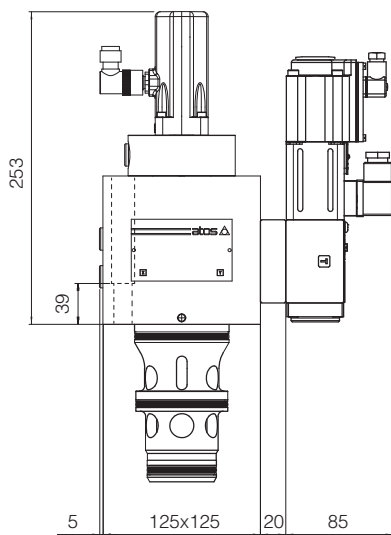

LIQZP-L-503

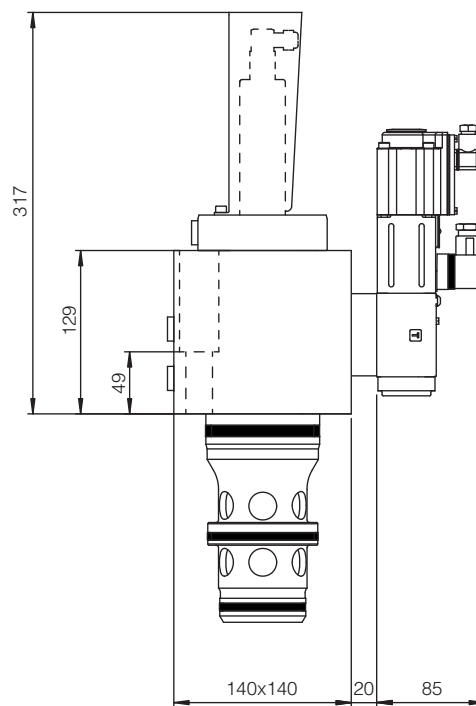

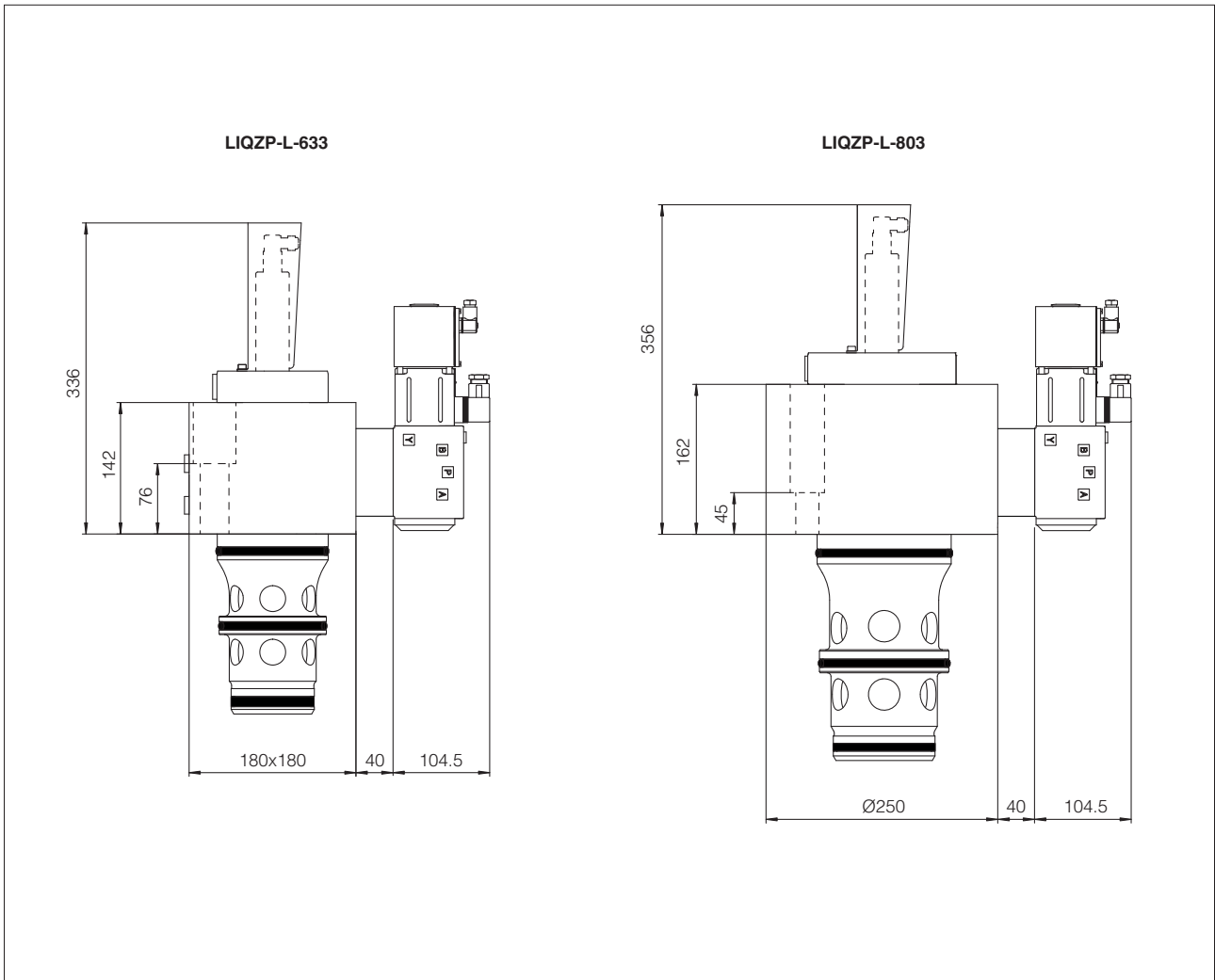

**Note:** for mounting surface and cavity dimensions, see table P006

### 13 RELATED DOCUMENTATION

<b>FS001</b>	Basics for digital electrohydraulics	<b>GS500</b>	Programming tools
<b>FS900</b>	Operating and maintenance information for proportional valves	<b>GS510</b>	Fieldbus
<b>GS230</b>	E-BM-LEB digital driver	<b>K800</b>	Electric and electronic connectors
<b>GS240</b>	E-BM-LES digital driver	<b>P006</b>	Mounting surfaces and cavities for cartridge valves