

Operating and maintenance information

for ex-proof proportional valves

This operating and maintenance information applies to Atos ex-proof proportional valves and is intended to provide useful guidelines to avoid risks when the valves are installed in a system operating in hazardous areas with explosive or flammable environment. The prescriptions included in this document must be strictly observed to avoid damages and injury. The respect of this operating and maintenance information grant an increased working life, trouble-free operation and thus reduced repairing costs. Information and notes on the transport and storage of the valves are also provided.

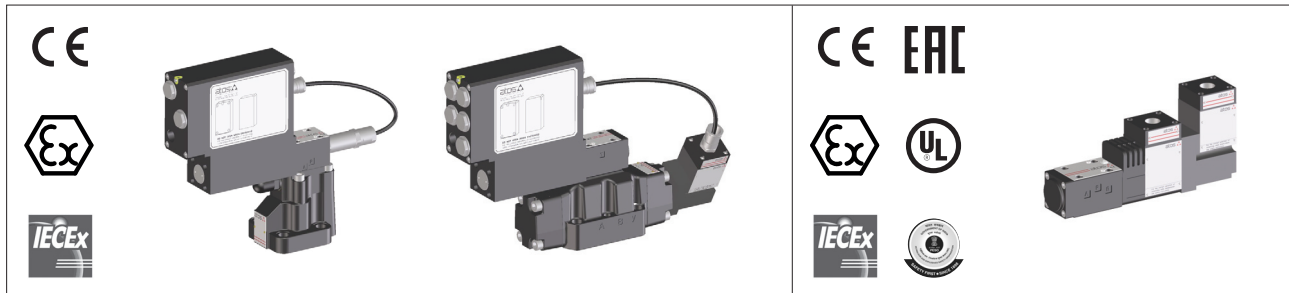

1 SYMBOL CONVENTIONS

This symbol refers to possible danger which can cause serious injuries

2 GENERAL NOTES

The operating and maintenance information is part of the operating instructions for the complete machine but it cannot replace them.

This document is relevant to the installation, use and maintenance of proportional directional, flow and pressure control valves equipped with ex-proof proportional solenoid and on-board driver type OZA-* and MZA-* for application in explosive hazardous environments.

2.1 Warranty

All the ex-proof proportional valves have 1 year warranty; the expiration of warranty results from the following operations:

- unauthorized mechanical or electronic operations
- the ex-proof proportional valves are not used exclusively for their intended purpose as defined in these operating and maintenance instructions

Service work performed on the valve by the end users or not qualified personnel invalidates the certification

3 CERTIFICATIONS AND PROTECTION MODE

3.1 Valves with on-board driver/axis controller

The ex-proof proportional valves subject of this operating and maintenance information are certified ATEX or IECEx. They are in compliance with following protection mode:

II 2 G Ex d IIC T6, T5, T4 Gb

II 2 D Ex tb IIIC T85°C, T100°C, T135°C Db

3.2 Valves with off-board driver/axis controller

The ex-proof solenoids subject of this operating and maintenance information are multicertified ATEX, IECEx, EAC, PESO or cULus. They are in compliance with following protection mode:

Multicertification Group II – ATEX, IECEx, EAC, PESO

II 2 G Ex d IIC T6, T4, T3 Gb

II 2 D Ex tb IIIC T85°C, T135°C, T200°C Db

Multicertification Group I (mining) – ATEX, IECEx

I M2 Ex d I Mb

cULus Noth American certification

Class I, Div. I, Groups C & D T. class T4/T3

Class I, Zone I, Groups II A & II B T. class T4/T3

4 HARMONIZED STANDARDS

The Essential Health and Safety Requirements are assured by compliance to the following standards:

ATEX

- EN 60079-0 Explosive atmospheres - Equipment: General requirements
- EN 60079-1 Explosive atmospheres - Equipment protection by flameproof enclosures "d"
- EN 60079-31 Explosive atmospheres - Equipment dust ignition protection by enclosures "t"

IECEX

- IEC 60079-0 Explosive atmospheres - Part 0: General requirements
- IEC 60079-1 Explosive atmospheres - Part 1: Equipment protection by flameproof enclosures "d"
- IEC 60079-31 Explosive atmospheres - Part 31: Equipment dust ignition protection by enclosures "t"

5 GENERAL CHARACTERISTICS

Ambient temperature range	Standard = -20°C ÷ +60°C /PE option = -20°C ÷ +60°C /BT option = -40°C ÷ +60°C
Storage temperature range	Standard = -20°C ÷ +70°C /PE option = -20°C ÷ +70°C /BT option = -40°C ÷ +70°C
Surface protection	Zinc coating with black passivation - salt spray test (EN ISO 9227) > 200 h
Compliance	Explosion proof protection -Flame proof enclosure "Ex d" -Dust ignition protection by enclosure "Ex t" RoHs Directive 2011/65/EU as last update by 2015/65/EU REACH Regulation (EC) n°1907/2006

6 HYDRAULIC CHARACTERISTICS

See technical tables relevant to the specific components, listed in section 12

7 ELECTRICAL CHARACTERISTICS

7.1 Valves with on-board driver/axis controller

Characteristics:

The power limitation is obtained by feeding the solenoid with current of 2,75 A, controlled by the on-board electronic driver/axis controller:

- Power supply: 24 VDC ±10 % stabilized - Rectified and filtered : VRMS = 20 ÷ 32 VMAX (ripple max 10 % VPP)
- Current supply: I_{MAX} = 2,75 A PWM square wave type
- Max power consumption: 35 W
- Output protection: against short circuit

Note: 2,5 A external fuse type RVT (fast) must be provided on the power supply line

For details see technical tables relevant to the specific components, listed in section 12

7.2 Valves with off-board driver/axis controller

Solenoid characteristics:

- Max power consumption: 35 W
- Coil resistance R at 20°C: 3,2 Ω; 17,6 Ω (option /24)
- Max solenoid current: 2,5 A; 1,1 A (option /24)

For details see technical tables relevant to the specific components, listed in section 12

Off-board driver/axis controller characteristics:

The power limitation is obtained by feeding the solenoid with current of 2,5 A, controlled by following off-board driver/axis controller:

- Power supply: 24 VDC ±10 % stabilized - Rectified and filtered : VRMS = 20 ÷ 32 VMAX (ripple max 10 % VPP)
- Current supply: I_{MAX} = 2,5 A PWM square wave type
- Output protection: against short circuit

Note: 2,5 A external fuse type RVT (fast) must be provided on the power supply line

For valves without transducer:

- E-BM-AS-*/A see tech table G030
- E-BM-AES-*/A see tech table GS050

For valves with LVDT transducer:

- E-BM-TEB/LEB-*/A see tech table GS230
- E-BM-TES/LES-*/A see tech table GS240
- Z-BM-TEZ/LEZ-*/A see tech table GS330

8 NAMEPLATES



8.1 Valve with on-board driver/axis controller - ATEX and IECEx certification

Gas - group II 2G - Zone 1, 2

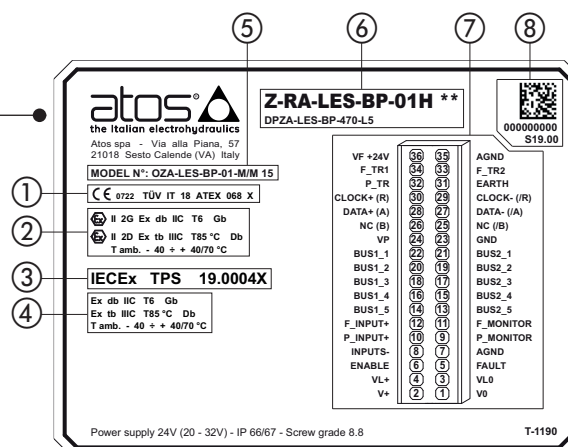
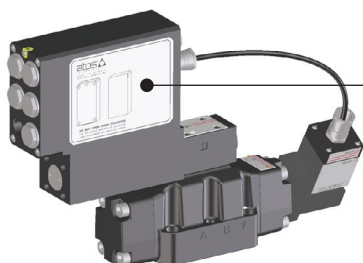
Dust - group II 2D - Zone 21, 22



- ① ATEX notified body and certificate number
- ② Marking according to ATEX Directive
- ③ IECEx notified body and certificate number
- ④ Marking according to IECEx Scheme
- ⑤ Code of solenoid
- ⑥ Code of on-board driver and related proportional valve
- ⑦ Electronic connections
- ⑧ Qr code and driver serial number

	Mark of conformity to the applicable European directives
	Mark of conformity to the 2014/34/EU directive and to the relevant technical norms
II 2 G	Equipment for surface plants with gas and vapors environment, category 2, suitable for zone 1 and zone 2
Ex db	Explosion-proof equipment
II C	Group II C equipment suitable for substances (gas) for group II C
T6	Equipment temperature class (maximum surface temperature)
Gb	Equipment protection level, very high level protection for explosive Gas atmospheres
II 2 D	Transducer for surface plants with dust environment, category 2, suitable for zone 21 and zone 22
Ex tb	Equipment protection by enclosure "tb"
III C	Suitable for conductive dust (applicable also IIB and/or IIIA)
IP66/67	Protection degree
T85°C	Maximum surface temperature (Dust)
Db	Equipment protection level, high level protection for explosive Dust atmospheres
TUV IT 18 ATEX 068 X	Name of the laboratory responsible for the CE certification: 18 year of the certification release; 068 X certification number
0948	Number of the Certified Body authorized for the production quality system certification
IECEx TPS 19.0004X	Certificate number: TPS laboratory name responsible for the IECEx certification scheme: 19 year of the certification release; 0004X number of certification
T amb.	Ambient temperature range

Notes:

The group IIC solenoids are suitable for IIA and IIB environments.

The T6 temperature class solenoids are suitable for all the substances having higher temperature class (T5, T4, T3, T2, T1).

The T5 temperature class solenoids are suitable also for all the substances having higher temperature class (T4, T3, T2, T1).

8.2 Valve with off-board driver/axis controller - ATEX, IECEx, EAC and PESO

Gas - group II 2G - Zone 1, 2

Dust - group II 2D - Zone 21, 22

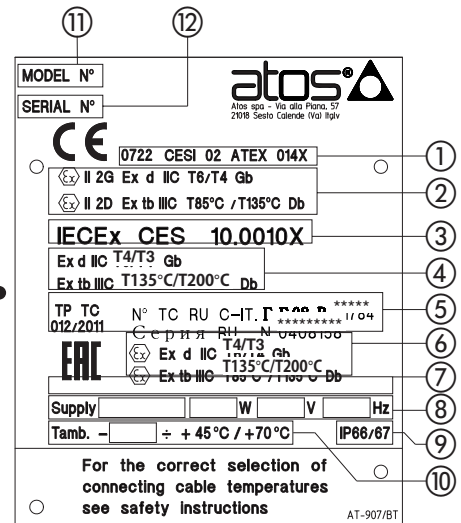
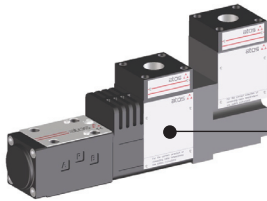

- ① ATEX notified body and certificate number
- ② Marking according to ATEX Directive
- ③ IECEx notified body and certificate number
- ④ Marking according to IECEx Scheme
- ⑤ EAC notified body and certificate number
- ⑥ Marking according to EAC
- ⑦ PESO certificate number
- ⑧ Power supply characteristics
- ⑨ Ingress protection:
 - IP66 = no dust ingress, protection against heaving seas or powerful jets of water
 - IP67 = no dust ingress, protection to water immersion
- ⑩ Ambient temperature
- ⑪ Solenoid model code
- ⑫ Solenoid serial number

	Mark of conformity to the applicable European directives
	Mark of conformity to the 2014/34/EU directive and to the relevant technical norms
II 2 G	Equipment for surface plants with gas and vapors environment, category 2, suitable for zone 1 and zone 2
Ex d	Explosion-proof equipment
II C	Group II C equipment suitable for substances (gas) for group II C
T4, T3	Solenoid temperature class (maximum surface temperature)
Gb	Equipment protection level, very high level protection for explosive Gas atmospheres
II 2 D	Equipment for surface plants with dust environment, category 2, suitable for zone 21 and zone 22
Ex tb	Equipment protection by enclosure "tb"
III C	Suitable for conductive dust (applicable also IIIB and/or IIIA)
IP66/67	Protection degree
T85°C, T135°C, T200°C	Maximum surface temperature (Dust)
Db	Equipment protection level, high level protection for explosive Dust atmospheres
CESI 02 ATEX 014 X	Name of the laboratory responsible for the CE certification: 02 year of the certification release; 014 X certification number
0722	Number of the Certified Body authorized for the production quality system certification: 0722 = CESI
IECEx CES 10.0010X	Certificate number: CES laboratory name responsible for the IECEx certification scheme: 10 year of the certification release; 0010X number of certification
T amb.	Ambient temperature range

8.3 Valve with off-board driver/axis controller - ATEX and IECEx

Gas - group I M2 - Mining

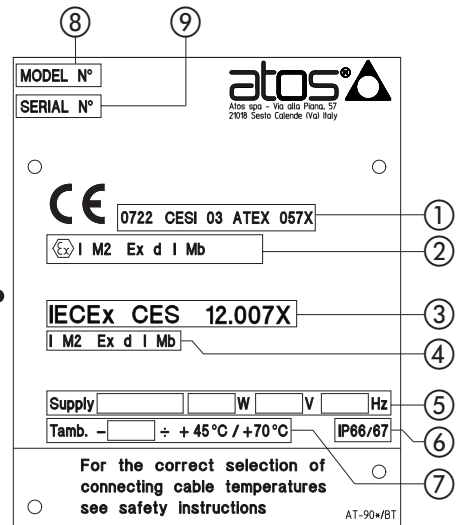

- ① ATEX notified body and certificate number
- ② Marking according to ATEX Directive
- ③ IECEx notified body and certificate number
- ④ Marking according to IECEx Scheme
- ⑤ Power supply characteristics
- ⑥ Ingress protection:
 - IP66 = no dust ingress, protection against heaving seas or powerful jets of water
 - IP67 = no dust ingress, protection to water immersion
- ⑦ Ambient temperature
- ⑧ Solenoid model code
- ⑨ Solenoid serial number

CE	Mark of conformity to the applicable European directives
Ex	Mark of conformity to the 2014/34/UE directive and to the technical norms
I M2	Equipment for mining (or relevant surface plants) which could be exposed to gas and / or flammable dust. The power supply of these equipment has to be switched off in case of explosive atmosphere.
Ex d	Explosion-proof equipment
I	Group I equipment suitable for substances (gas) for group I
Mb	Equipment protection level, high level protection for explosive atmospheres
CESI 03 ATEX 057 X	Name of the laboratory responsible for the CE certification: 03 year of the certification release; 057 certification number X= reduced risk of mechanical shock (the equipment has to be protected from mechanical shocks)
0722	Number of the Certified Body authorized for the production quality system certification: 0722 = CESI
IECEx CES 12.007X	Certificate number: CES laboratory name responsible for the IEC Ex certification scheme: 12 year of the certification release; 007X number of certification
T amb.	Ambient temperature range

8.4 Valve with off-board driver/axis controller - cULus certification

Class I, Division I, Groups C and D
Class I, Zone I, Groups IIA and IIB



⑤	MODEL CODE	⑥			DRILLING INSTRUMENTATION FOR HAZARDOUS LOCATIONS	①
	SERIAL N°					
	Class I, Div. I, Groups C & D	T. class T6/T5				②
	Class I, Zone I, Groups IIA & IIB	T. class T6/T5				③
	Max ambient temp.	55/70 °C 131/158 °F				④
	Electrical rating :	24 V DC 12W				
<p>CAUTION: To reduce the risk of ignition of hazardous atmospheres, disconnect from circuit before opening enclosure. Keep tightly closed when in operation.</p> <p>ATTENTION: Pour réduire le risque d'allumage des atmosphères dangereuses, déconnecter le circuit avant d'ouvrir le boîtier. Garder le bien fermé lorsqu'il est en fonctionnement</p> <p style="text-align: right;">T-880</p>						

- | | |
|--|--------------------------------|
| ① cULus marking and certificate number | ④ Power supply characteristics |
| ② Marking according to NEC 500 and NEC 505 standards | ⑤ Solenoid model code |
| ③ Ambient temperature | ⑥ Solenoid serial number |

	cULus mark and certificate number
Class I	Equipment for flammable gas and vapours
Division I	Explosive substances continuously or intermittently present in the atmosphere
Groups C & D	Gas group C (Methane, Buthane, Petrol, etc) and D (Etylene, Formaldeyde, Cloruprophane, etc)
Zone I	Location where explosive substances are continuously present
Groups IIA & IIB	Equipment of group IIA and IIB suitable for gas of group IIA and IIB
Class T6/T5	Solenoid temperature class (maximum surface temperature)
Max ambient temp.	Max ambient temperature range in °C and °F

9 SAFETY NOTES

9.1 Improper use

Any improper use of the components is not admissible. Improper use of the product includes:

- Wrong installation / installation in areas not approved for the specific component
- Incorrect cleanliness during storage and assembly
- Use of inappropriate or non-admissible hydraulic fluids
- Use outside of the specified performance limits
- Use of inappropriate electrical power supply
- Incorrect transport

9.2 Installation

The installation or use of inappropriate components in explosive hazardous environments could cause personal injuries and damage to property.

For the application in explosion hazardous environments, the compliance of the solenoid with the zone classification and with the flammable substances present in the system must be verified.

The main safety requirements against the explosion risks in the classified areas are established by the European Directives 2014/34/UE (for the components) and 99/92/CE (for the plants and safety of the workers against the risk of explosion).

The classification criteria of the area against the explosion risks are established by the norm EN60079-10.

The technical requirements of the electrical systems are established by the norm EN60079-14 (group II).

Note: the max fluid temperature controlled by the valve must not exceed + 60°C

Ensure that no explosive atmosphere may occur during the valve installation.
Only use the valve in the intended explosion protection area.
The ignition temperature of the hydraulic fluid used must be 50°C higher than the maximum surface temperature of the valve.

Use of the valve outside the approved temperature ranges may lead to functional failures like e.g. overheating of the valve solenoid/driver. This means that the explosion protection is no longer ensured.

Only use the valve within the fluid temperature range.

During operation, touch the valve solenoid only by using protective gloves.

Unload the system pressure before working on the valve.

Danger of serious injury can be caused by a powerful leaking of hydraulic fluid jet.

Before working on the valve, ensure that the hydraulic system is depressurized and the electrical control is de-energized.

Before operating/connect the valve with the programming software the user must read the user manual carefully: programming software can change/inhibit the behaviour of the valve causing damage and injury!

During store/restore operations of the electronic driver/axis control permanent memory:

- current to valve solenoid is switched off: operate store/restore with no active valve regulation in the system
- do not turn off power supply: driver/axis control parameter lose may occur

Faults of driver/axis control may compromise safety or change operating conditions, shut down the driver/axis control immediately and notify qualified personnel.

9.3 Electrical connection - valve with on-board driver/axis controller

Electrical connections to the external circuits are achieved through 36 poles terminal block installed on a PCB fixed inside driver housing. The threaded cable entrance is provided with a cylindrical thread M20x1,5 UNI 4535.

The cable glands used for the cable entrance must be certified for the specific hazardous environment – see tech. table **KX800** for Atos ex-proof cable glands.

Note: a Loctite sealant type 545, should be used on the cable gland entry threads

The electrical cables must be suitable for the working temperatures as shown in the section 9.4

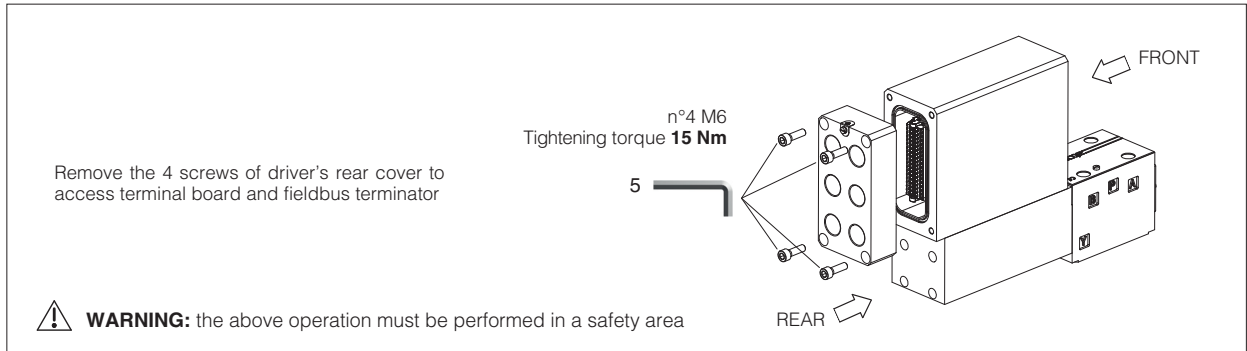

9.4 Cable specification and temperature - Valve with on-board driver/axis controller

Power supply and signals: section of wire = 1,0 mm ²	Grounding: section of external ground wire = 4 mm ²
--	---

Cable temperature

Max ambient temperature [°C]	Temperature class	Max surface temperature [°C]	Min. cable temperature [°C]
40 °C	T6	85 °C	80 °C
55 °C	T5	100 °C	90 °C
70 °C	T4	135 °C	110 °C

9.5 Electrical connection - valve off-board driver/axis controller

The connection to the external circuit is made with a screw clamps 2 poles + ground, installed inside the solenoid and transducer housing. The eventual requirement of the additional ground connection on the solenoid housing must be made on the relative screw (M3x6 UNI-6107).

The threaded cable entrance is provided with one of following optional connections:

- conical thread 1/2" NPT ANSI B2.1
- conical thread GK-1/2" "(Annex 1 CEI EN 60079-1 2008-11) only for the Italian market
- cylindrical thread M20x1,5 UNI 4535

The cable glands used for the cable entrance must be certified for the specific hazardous environment – see tech. table **KX800** for Atos ex-proof cable glands.

Note: a Loctite sealant type 545, should be used on the cable gland entry threads

The electrical cables must be suitable for the working temperatures as shown in the section 9.6

LVDT main stage transducer - only for DPZA-T

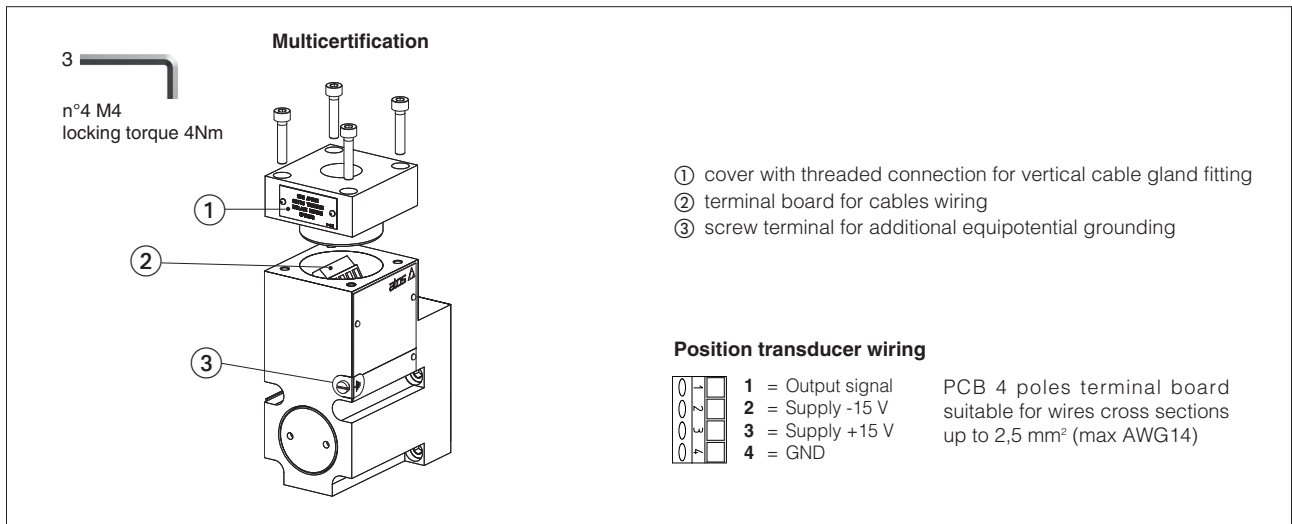

Valve without LVDT transducer

Multicertification

Standard version **Option /O**

cULus certification

Standard version **Option /O**

① cover with threaded connection for vertical cable gland fitting
 ② cover with threaded connection for horizontal cable gland fitting
 ③ terminal board for cables wiring
 ④ standard manual override
 ⑤ screw terminal for additional equipotential grounding

0	1	1 = Coil PCB 3 poles terminal board suitable for wires cross sections up to 2,5 mm ² (max AWG14)
0	2	
0	3	

Pay attention to coil polarity

1 = Coil + PCB 3 poles terminal board suggested cable section up to 1,5 mm²
 2 = GND
 3 = Coil - (max AWG16)

alternative GND screw terminal connected to solenoid housing

Valve with LVDT transducer

Multicertification

Standard version **Option /O**

cULus certification

Standard version **Option /O**

① solenoid cover with threaded connection for cable gland fitting
 ② transducer cover with threaded connection for cable gland fitting
 ③ solenoid terminal board for cables wiring
 ④ transducer terminal board for cables wiring
 ⑤ screw terminal for additional equipotential grounding

Solenoid wiring

0	1	1 = Coil PCB 3 poles terminal board suitable for wires cross sections up to 2,5 mm ² (max AWG14)
0	2	
0	3	

Position transducer wiring

0	1	1 = Output signal PCB 4 poles terminal board suitable for wires cross sections up to 2,5 mm ² (max AWG14)
0	2	
0	3	
0	4	

Pay attention to respect the polarity

1 = Coil + PCB 3 poles terminal board suggested cable section up to 1,5 mm²
 2 = GND (max AWG16), see section 9.6 note 1
 3 = Coil -

alternative GND screw terminal connected to solenoid housing

Position transducer wiring

1 = Output signal PCB 4 poles terminal board
suggested cable section up to 1,5 mm² (max AWG16),
see section 9.6 note 1
 2 = Supply -15 V
 3 = Supply +15 V
 4 = GND

LVDT main stage transducer - only for LIQZA-L

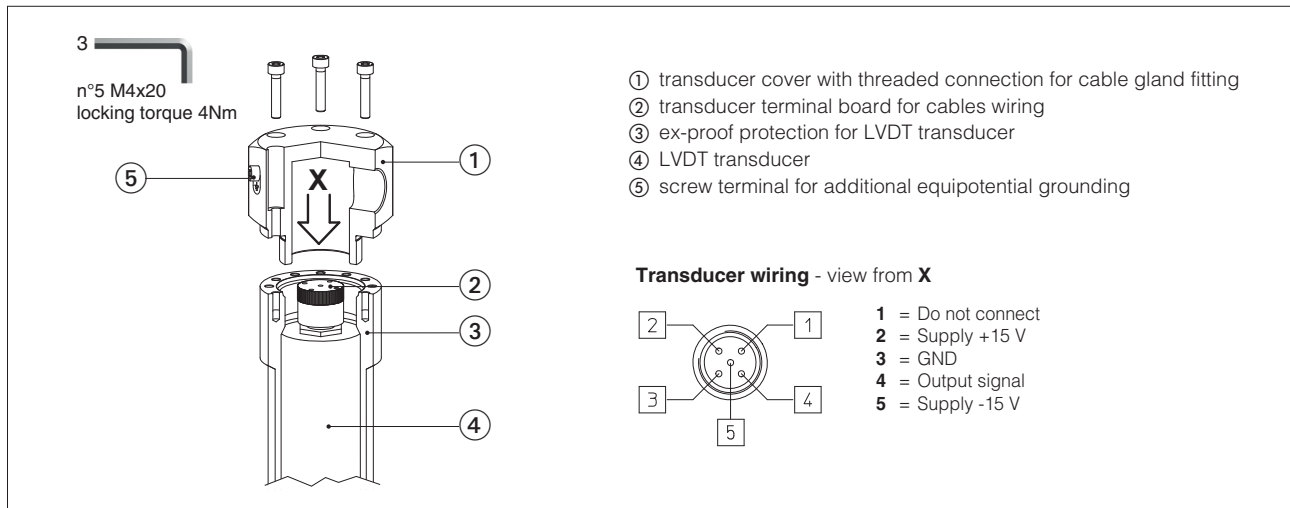

9.6 Cable specification and temperature - Valve with off-board driver/axis controller

Cable specification - Multicertification Group I and Group II

Power supply: section of coil connection wires = 2,5 mm²

Grounding: section of internal ground wire = 2,5 mm²
 section of external ground wire = 4 mm²

Cable temperature - Multicertification Group I and Group II

Max ambient temperature [°C]	Temperature class		Max surface temperature [°C]		Min. cable temperature [°C]	
	Goup I	Goup II	Goup I	Goup II	Goup I	Goup II
40 °C	-	T4	150 °C	-	90 °C	-
45 °C	-	T4	150 °C	135 °C	-	90 °C
55 °C	-	T3	150 °C	200 °C	-	110 °C
60 °C	-	-	150 °C	-	110 °C	-
70 °C	N.A.	T3	N.A.	200 °C	N.A.	120 °C

Cable specification - cULus certification

- Suitable for use in Class I Division 1, Gas Groups C
- Armored Marine Shipboard Cable which meets UL 1309
- Tinned Stranded Copper Conductors
- Bronze braided armor
- Overall impervious sheath over the armor

Any Listed (UBVZ/UBVZ7) Marine Shipboard Cable rated 300 V min, 15A min. 3C 2,5 mm² (14 AWG) having a suitable service temperature range of at least -25°C to +110°C ("BT" Models require a temperature range from -40°C to +110°C)

Note 1: for Class I wiring the 3C 1,5 mm² AWG 16 cable size is admitted only if a fuse lower than 10 A is connected to the load side of the solenoid wiring

Cable temperature - cULus certification

Max ambient temperature [°C]	Temperature class	Max surface temperature [°C]	Min. cable temperature [°C]
55 °C	T4	135 °C	100 °C
70 °C	T3	200 °C	100 °C

9.7 Hydraulic fluids and operating viscosity range

Mineral oils type HLP having high viscosity index are recommended.

The hydraulic fluids must be compatible with the selected seals.

Make sure that the working fluid is compatible with gas and dust present in the environment. The type of fluid has to be selected in consideration of the effective working temperature range, so that the fluid viscosity remains at the optimal level.

Hydraulic fluid	Suitable seals type	Classification	Ref. Standard
Mineral oils	NBR, FKM, HNBR	HL, HLP, HLPD, HVL, HVLDP	DIN 51524
Flame resistant without water	FKM	HFDU, HFDR	ISO 12922
Flame resistant with water	NBR, HNBR	HFC	

Fluid viscosity: 20 ÷ 100 mm²/s - max allowed range 15 ÷ 380 mm²/s

9.8 Filtration

The correct fluid filtration ensures a long service life of the valves and it prevent anomalous wearing or sticking.



Contamination in the hydraulic fluid may cause functional failures e.g. jamming or blocking of the valve spool / poppet. In the worst case, this may result in unexpected system movements and thus constitute a risk of injury.

Ensure adequate hydraulic fluid cleanliness according to the cleanliness classes of the valve over the entire operating range.

Max fluid contamination level, see also filter section at www.atos.com or KTF catalog:

- normal operation: ISO4406 class 18/16/13 NAS1638 class 7
- longer life: ISO4406 class 16/14/11 NAS1638 class 5

10 MAINTENANCE



Maintenance must be carried out only by qualified personnel with a specific knowledge of hydraulics and electrohydraulics

10.1 Ordinary maintenance



Service work performed on the valve by end user or not qualified personnel invalidates the certification

- The valves does not require other maintenance operations except seals replacement
- Results of maintenance and inspection must be planned and documented
- Follow the maintenance instructions of the fluid manufacturer
- Any preventive maintenance should be performed only by experienced personnel authorized by Atos.
- Cleaning the external surfaces using a wet cloth to avoid accumulation of dust layer over 5 mm
- Don't use compressed air for cleaning to avoid any dangerous dust dispersion on the surrounding atmosphere
- Any sudden increment in temperature requires the immediate stop of the system and the inspection of the relevant components

10.2 Repairing

In case of incorrect functioning or beak-down it is recommended to send the valve back to Atos or to Atos authorized service centers which will provide for the reparation.

Unauthorized opening of the valves during the warranty period invalidates the warranty and invalidates the certification tools for repairing.



The intrinsically safe solenoids must not be opened.
Any tampering invalidates the certification and it may cause serious dangerous.

11 TRANSPORT AND STORAGE

11.1 Transport

Observe the following guidelines for transportation of valves:

- Before any movement check the valve weight reported in the technical table relevant to the specific component
- Use soft lifting belts to move or lift the heavy valves to avoid damages



Danger of damage to property and personal injuries!

The valve may fall down and cause damage and injuries, if transported improperly:

- Use the original packaging for transport
- Use personal protective equipment, such as: gloves, working shoes, safety goggles, working clothes, etc.

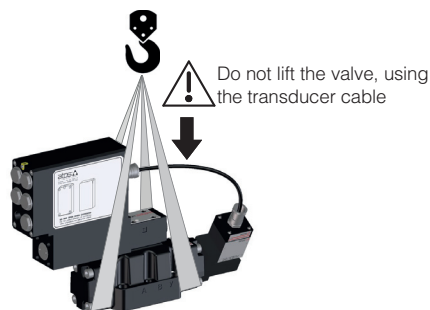

11.2 Storage

Valve's corrosion protection is achieved with zinc coating; this treatment protect the valve to grant a storage period up to 12 months. Additionally all valves are tested with mineral oil OSO 46; the oil film left after testing ensure the internal corrosion protection.

In case of storage period longer than 12 months please contact our technical office.

Ensure that valves are well protected against water and humidity in case of storage in open air.

12 RELATED DOCUMENTATION

12.1 Valve with on-board driver/axis controller

Servoproportional directional - zero overlap with LVDT transducer

- FX150** DLHZA-TES, DLKZA-TES - direct, sleeve execution
FX135 DHZA-TES, DKZA-TES - direct
FX235 DPZA-LES, piloted
FX380 LIQZA-LES, 3-way cartridge

High performance directional - positive overlap with LVDT transducer

- FX130** DHZA-TES, DKZA-TES - direct
FX230 DPZA-LES - piloted
FX360 LIQZA-LES, 2-way cartridge

Directional valves - positive overlap without transducer

- FX110** DHZA-AES, DKZA-AES - direct
FX210 DPZA-AES - piloted

High performance pressure valves - with pressure transducer

- FX030** RZMA-RES, AGMZA-RES - relief
FX060 RZGA-RES, AGRCZA-RES - reducing
FX320 LIMZA-RES, LIRZA-RES, LICZA-RES - relief, reducing, compensator

Pressure valves - without transducer

- FX020** RZMA-AES, AGMZA-AES - relief
FX050 RZGA-AES, AGRCZA-AES - reducing
FX080 DHRZA-AES - reducing
FX310 LIMZA-AES - relief
 LIRZA-AES - reducing
 LICZA-AES - compensator

Flow valves, pressure compensated

- FX430** QVHZA-TES, QVKZA-TES - with LVDT transducer
FX410 QVHZA-AES, QVKZA-AES - without transducer

Servoproportional valves with on-board axis controller

- FX610** DLHZA-TEZ, DLKZA-TEZ - direct, sleeve execution
FX620 DHZA-TEZ, DKZA-TEZ - direct
FX630 DPZA-LEZ - piloted

12.2 Valve with off-board driver/axis controller

Servoproportional directional - zero overlap with LVDT transducer

- FX140** DLHZA-T, DLKZA-T - direct, sleeve execution
FX370 LIQZA-L, 3-way cartridge

High performance directional - positive overlap with LVDT transducer

- FX120** DHZA-T, DKZA-T - direct
FX220 DPZA-T - piloted
FX350 LIQZA-L, 2-way cartridge

Directional valves - positive overlap without transducer

- FX100** DHZA-A, DKZA-A - direct
FX200 DPZA-A - piloted

Pressure valves - without pressure transducer

- FX010** RZMA-A, HZMA-A, AGMZA-A - relief
FX040 RZGA-A, AGRCZA-A, HZGA-A, KZGA-A - reducing
FX070 DHRZA-A - reducing
FX300 LIMZA-A - relief
 LIRZA-A - reducing
 LICZA-A - compensator

Flow valves, pressure compensated

- FX420** QVHZA-T, QVKZA-T - with LVDT transducer
FX400 QVHZA-A, QVKZA-A - without transducer