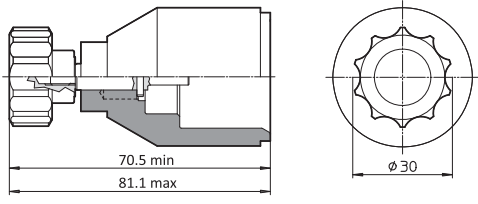
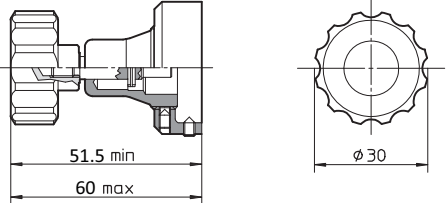
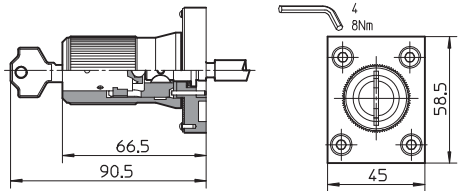
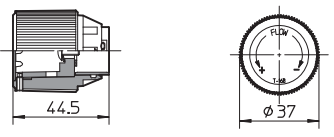
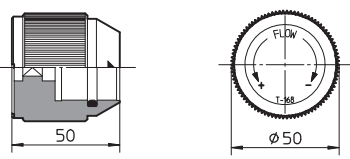

Handwheels for hydraulic controls

on-off and proportional valves

	OPTIONS CODES AND DIMENSIONS	FEATURES	VALVE TYPE
OPTION	<p>IV</p>	Regulating handwheel	ARE, CART ARE, CART M-6, ARAM, AGAM, REM, AGIR, AGIS, AGIU, HMP, HM, KM, HS, KS, HG, KG, LIMM, LIRA, LICM
OPTION	<p>IVF</p>	Regulating knob	ARE, CART ARE, CART M-6, AGIS, AGIU (as spare part, code VFG instead of VF and VSG instead of VS), HMP, HS, HG.
OPTION	<p>VS</p>	Manual override with safety locking. Regulation possible only with pushed knob.	HMP, HS, HG.
OPTION	<p>/WP</p>	Prolonged manual override protected by rubber cap	DHI, DHE DKE DLEH, DLEHM DPHI, DPHE LID*
SPARE PART	<p>WPD/HL</p>		DHL (only DC version)
SPARE PART	<p>WPD/H</p>	Manual override with detent, for mechanical operation and fixed actuation of spools	DHI
SPARE PART	<p>WPD/HE-DC</p>		DHE (only DC version)

	OPTIONS CODES AND DIMENSIONS	FEATURES	VALVE TYPE
SPARE PART	<p>WPD/KE-DC</p> 	Manual override with detent, for mechanical operation and fixed actuation of spools	DKE-DC
SPARE PART	<p>WPD/Z</p> 	Manual override with detent, for mechanical operation and fixed actuation of spools. Only for open-loop valves.	DHZO, DKZOR, DPZO, QVHZO, QVKZOR
OPTION	<p>/K</p> 	Lock key for the setting knob	DHQ, DKQ QV-06,
OPTION	<p>/G</p> 	Adjustment by graduated micrometer	HQ, KQ, JPQ-2
OPTION	<p>/G</p> 		JPQ-3