

3 VALVE SETTINGS AND PROGRAMMING TOOLS

Valve's functional parameters and configurations, can be easily set and optimized using Atos E-SW-BASIC programming software connected via USB port to the digital driver, see tech. table **GS500**.

WARNING: drivers **USB port is not isolated!** For E-C-SB-USB/M12 cable, the use of isolator adapter is highly recommended for PC protection

WARNING: see tech table **GS500** for the list of countries where the Bluetooth adapter has been approved

USB or Bluetooth connection

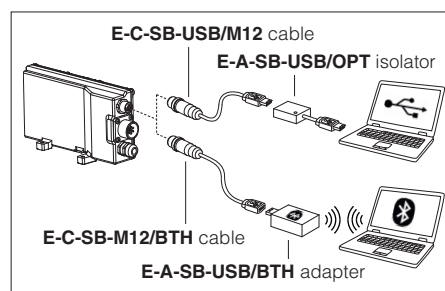

4 GENERAL CHARACTERISTICS

Assembly position	Any position
Subplate surface finishing to ISO 4401	Acceptable roughness index: Ra ≤ 0,8, recommended Ra 0,4 – Flatness ratio 0,01/100
MTTFd valves according to EN ISO 13849	150 years, see technical table P007
Ambient temperature range	Standard = -20°C ÷ +60°C /PE option = -20°C ÷ +60°C
Storage temperature range	Standard = -20°C ÷ +70°C /PE option = -20°C ÷ +70°C
Surface protection	Zinc coating with black passivation (body), tin plating (driver housing)
Corrosion resistance	Salt spray test (EN ISO 9227) > 200 h
Conformity	CE according to EMC directive 2014/30/EU (Immunity: EN 61000-6-2; Emission: EN 61000-6-3) RoHS Directive 2011/65/EU as last update by 2015/863/EU REACH Regulation (EC) n°1907/2006

5 HYDRAULIC CHARACTERISTICS - based on mineral oil ISO VG 46 at 50 °C

Valve model	DHZE							DKZE								
	ports P, A, B = 350; T = 210							ports P, A, B = 315; T = 210								
Spool type (1)	L3, S3		D3		L5, S5		D5		L3, S3		D3		L5, S5		D5	
Nominal flow Δp P-T [l/min]			P-A A-T	P-B B-T			P-A A-T	P-B B-T			P-A A-T	P-B B-T			P-A A-T	P-B B-T
(2) Δp= 10 bar	18		18	9	28		28	14	45		45	22	75		75	37
Δp= 30 bar	30		30	15	50		50	25	80		80	40	130		130	65
Δp= 70 bar	45		45	22	75		75	37	120		120	60	170		170	85
Max permissible flow	50		50	25	80		80	40	130		130	65	180		180	90
Leakage [cm³/min]	<30 (at p = 100 bar); <135 (at p = 350 bar)							<80 (at p = 100 bar); <600 (at p = 315 bar)								
Response time (3) [ms]	≤ 15							≤ 20								
Hysteresis	≤ 0,2 [% of max regulation]															
Repeatability	± 0,1 [% of max regulation]															
Thermal drift	zero point displacement < 1% at ΔT = 40°C															

(1) For spool type **D*** the flow value is referred to Δp/2 per control edge

(2) For different Δp, the max flow is in accordance to the diagrams in section 8.2

(3) 0-100% step signal

6 ELECTRICAL CHARACTERISTICS

Power supply	Nominal : +24 VDC Rectified and filtered : VRMS = 20 ÷ 32 VMAX (ripple max 10 % VPP)
Max power consumption	50 W
Max. solenoid current	DHZE = 2,6 A DKZE = 3 A
Coil resistance R at 20°C	DHZE = 3,1 Ω DKZE = 3,2 Ω
Analog input signals	Voltage: range ±10 VDC (24 VMAX tollerant) Input impedance: Ri > 50 kΩ
Monitor outputs	Output range: voltage ±10 Vdc @ max 5 mA
Alarms	Solenoid not connected/short circuit, cable break with current reference signal, over/under temperature, valve spool transducer malfunctions, alarms history storage function
Insulation class	H (180°) Due to the occurring surface temperatures of the solenoid coils, the European standards ISO 13732-1 and EN982 must be taken into account
Protection degree to DIN EN60529	IP66 / IP67 with mating connectors
Duty factor	Continuous rating (ED=100%)
Additional characteristics	Short circuit protection of solenoid's current supply; spool position control by P.I.D. with rapid solenoid switching; protection against reverse polarity of power supply
Communication interface	USB - Atos ASCII coding
Communication physical layer	not insulated - USB 2.0 + USB OTG
Recommended wiring cable	LiYCY shielded cables, see section 12

Note: a maximum time of 400 ms have to be considered between the driver energizing with the 24 Vdc power supply and when the valve is ready to operate. During this time the current to the valve coils is switched to zero.

7 SEALS AND HYDRAULIC FLUID - for other fluids not included in below table, consult Atos Technical Office

Seals, recommended fluid temperature	NBR seals (standard) = -20°C ÷ +60°C, with HFC hydraulic fluids = -20°C ÷ +50°C FKM seals (/PE option) = -20°C ÷ +80°C		
Recommended viscosity	20 ÷ 100 mm ² /s - max allowed range 15 ÷ 380 mm ² /s		
Max fluid contamination level	normal operation	ISO4406 class 18/16/13 NAS1638 class 7	see also filter section at www.atos.com or KTF catalog
	longer life	ISO4406 class 16/14/11 NAS1638 class 5	
Hydraulic fluid	Suitable seals type	Classification	Ref. Standard
Mineral oils	NBR, FKM	HL, HLP, HLPD, HVLP, HVLPD	DIN 51524
Flame resistant without water	FKM	HFDU, HFDR	ISO 12922
Flame resistant with water	NBR	HFC	

8 DIAGRAMS (based on mineral oil ISO VG 46 at 50 °C)

8.1 Regulation diagrams - values measure at Δp 30 bar P-T

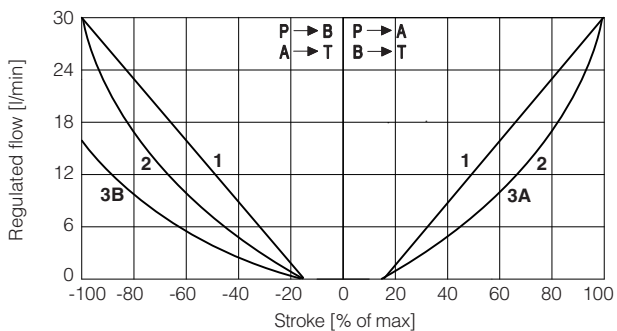

DHZE
1 = L3 **2** = S3 **3A** = D3 (P → A, A → T)
3B = D3 (P → B, B → T)

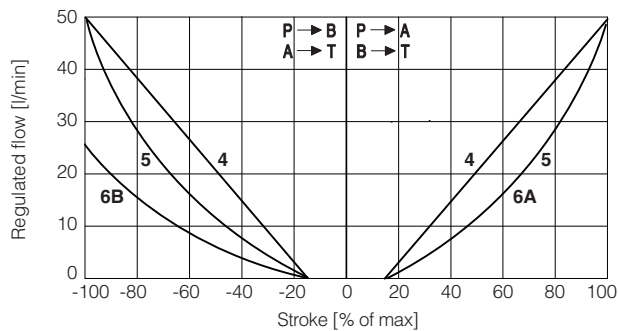

DHZE
4 = L5 **5** = S5 **6A** = D5 (P → A, A → T)
6B = D5 (P → B, B → T)

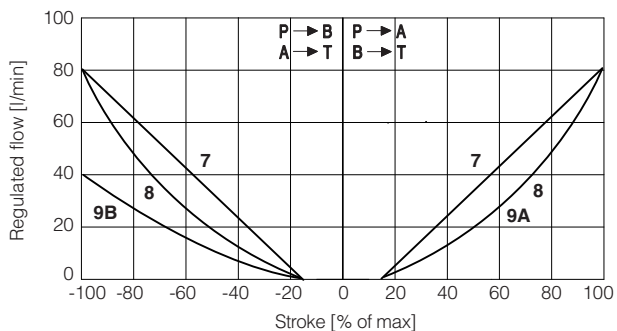

DKZE
7 = L3 **8** = S3 **9A** = D3 (P → A, A → T)
9B = D3 (P → B, B → T)

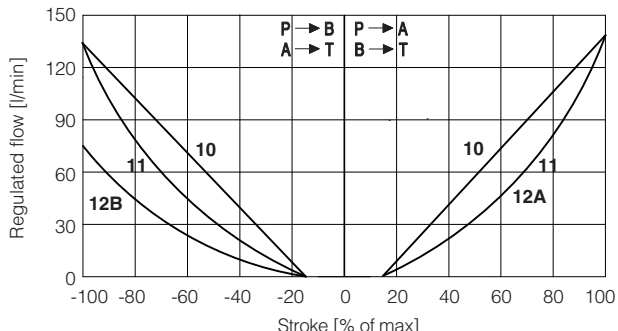

DKZE
10 = L5 **11** = S5 **12A** = D5 (P → A, A → T)
12B = D5 (P → B, B → T)

Note: Hydraulic configuration vs. reference signal for configuration 71 and 73 (standard and option /B)

Reference signal 0 ÷ +10 V } P → A / B → T

Reference signal 0 ÷ -10 V } P → B / A → T

8.2 Operating limits

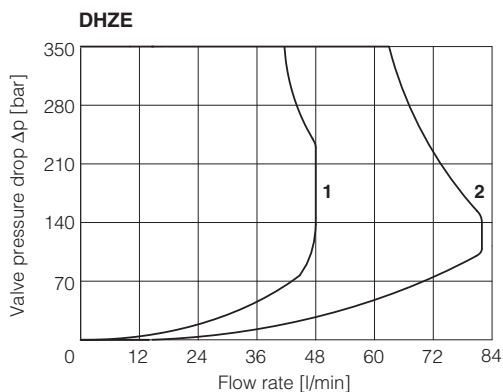

1 = spool L3, S3, D3 **2** = spool L5, S5, D5

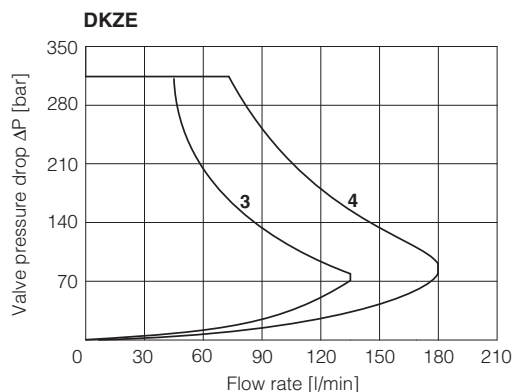

3 = spool S3, L3, D3 **4** = spool S5, L5, D5

9 OPTIONS

B = Configurations 51, 53: solenoid, on-board digital driver connections and LVDT transducer at side of port A.
Configurations 71, 73: on-board digital driver connections and LVDT transducer at side of port A.
For hydraulic configuration vs reference signal, see 8.1

10 POWER SUPPLY AND SIGNALS SPECIFICATIONS

Generic electrical output signals of the valve (e.g. monitor signal) must not be directly used to activate safety functions, like to switch-ON/OFF the machine's safety components, as prescribed by the European standards (Safety requirements of fluid technology systems and components-hydraulics, EN-982).

10.1 Power supply (V+ and V0)

The power supply must be appropriately stabilized or rectified and filtered: apply at least a 10000 μ F/40 V capacitance to single phase rectifiers or a 4700 μ F/40 V capacitance to three phase rectifiers.



A safety fuse is required in series to the power supply: 2,5 A time lag fuse.

10.2 Flow reference input signal (Q_INPUT+)

The driver controls in closed loop the valve spool position proportionally to the external reference input signal.
Default range is ± 10 Vdc

10.3 Flow monitor output signal (Q_MONITOR)

The driver generates an analog output signal proportional to the actual spool position of the valve; the monitor output signal can be software set to show other signals available in the driver.
Default range is ± 10 Vdc for standard

Note: Flow reference input signal and flow monitor output signal can be software selected with max range ± 10 Vdc

11 ELECTRONIC CONNECTIONS

11.1 Main connector signals - 7 pin (A1)

PIN	SIGNAL	TECHNICAL SPECIFICATIONS	NOTES
A	V+	Power supply 24 Vdc	Input - power supply
B	V0	Power supply 0 Vdc	Gnd - power supply
C	AGND	Analog ground	Gnd - analog signal
D	Q_INPUT+	Flow reference input signal: ± 10 Vdc maximum range Default is: ± 10 Vdc	Input - analog signal
E	INPUT-	Negative reference input signal for Q_INPUT+	Input - analog signal
F	Q_MONITOR	Flow monitor output signal: ± 10 Vdc maximum range, referred to AGND Default is: ± 10 Vdc	Output - analog signal
G	EARTH	Internally connected to driver housing	

11.2 Communication connectors (B)

(B) USB connector - M12 - 5 pin always present		
PIN	SIGNAL	TECHNICAL SPECIFICATION (1)
1	+5V_USB	Power supply
2	ID	Identification
3	GND_USB	Signal zero data line
4	D-	Data line -
5	D+	Data line +

11.3 Connections layout

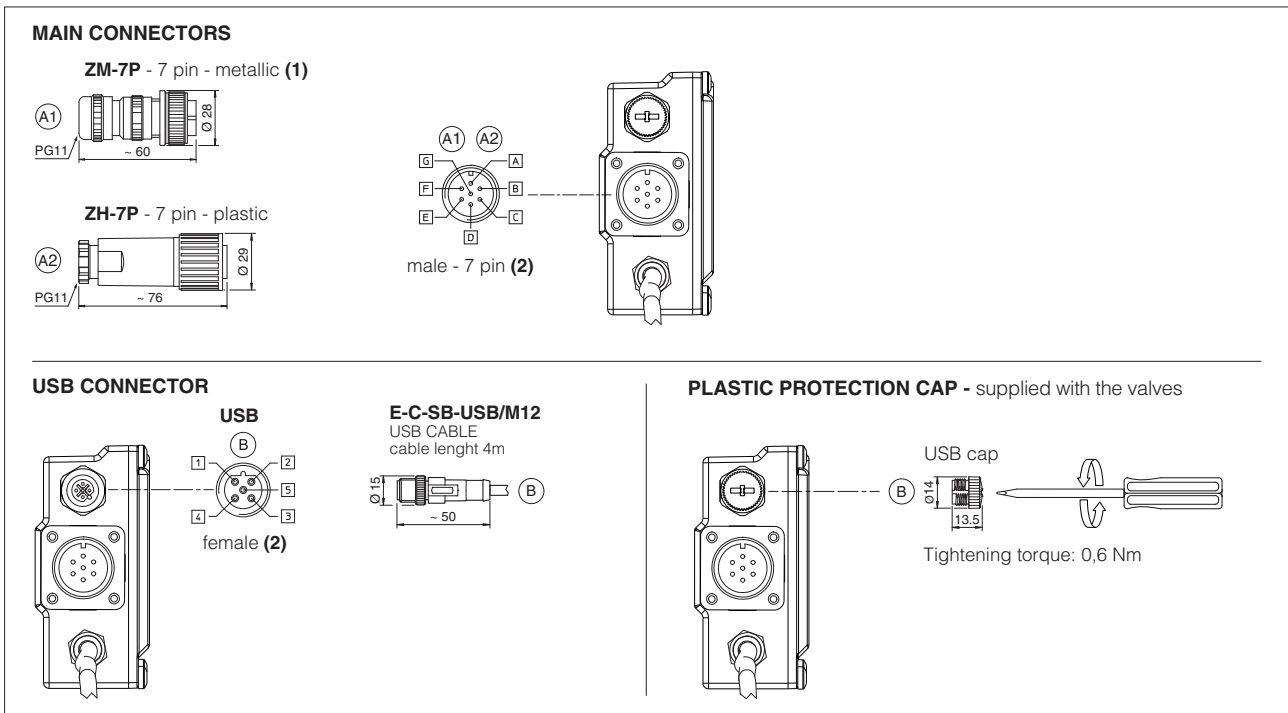

(1) use of metallic connectors is strongly recommended in order to fulfill EMC requirements (2) pin layout always referred to driver's view

12 CONNECTORS CHARACTERISTICS - to be ordered separately

CONNECTOR TYPE	POWER SUPPLY	
CODE	(A1) ZM-7P	(A2) ZH-7P
Type	7pin female straight circular	7pin female straight circular
Standard	According to MIL-C-5015	According to MIL-C-5015
Material	Metallic	Plastic reinforced with fiber glass
Cable gland	PG11	PG11
Recommended cable	LiYCY 7 x 0,75 mm ² max 20 m (logic and power supply) or LiYCY 7 x 1 mm ² max 40 m (logic and power supply)	LiYCY 7 x 0,75 mm ² max 20 m (logic and power supply) or LiYCY 7 x 1 mm ² max 40 m (logic and power supply)
Conductor size	up to 1 mm ² - available for 7 wires	up to 1 mm ² - available for 7 wires
Connection type	to solder	to solder
Protection (EN 60529)	IP 67	IP 67

13 FASTENING BOLTS AND SEALS

	DHZE	DKZE
	<p>Fastening bolts:</p> <p>4 socket head screws M5x30 class 12.9</p> <p>Tightening torque = 8 Nm</p>	<p>Fastening bolts:</p> <p>4 socket head screws M6x40 class 12.9</p> <p>Tightening torque = 15 Nm</p>
	<p>Seals:</p> <p>4 OR 108</p> <p>Diameter of ports A, B, P, T: Ø 7,5 mm (max)</p>	<p>Seals:</p> <p>5 OR 2050</p> <p>Diameter of ports A, B, P, T: Ø 11,2 mm (max)</p>

14 INSTALLATION DIMENSIONS [mm]

ISO 4401: 2000 (see table P005)
 Mounting surface: 4401-03-02-0-05

Valve	Mass [kg]
DHZE-05*	2,5
DHZE-07*	3

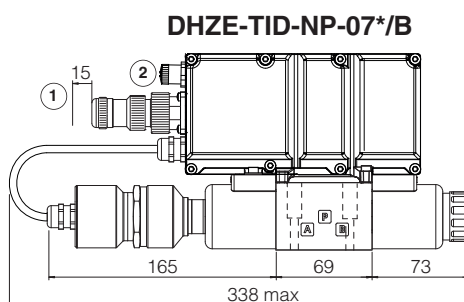
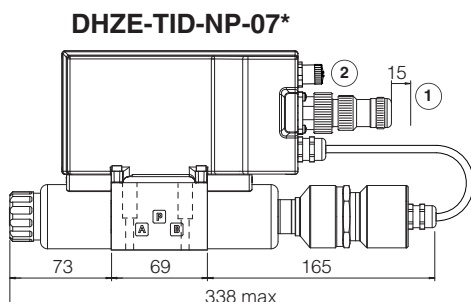
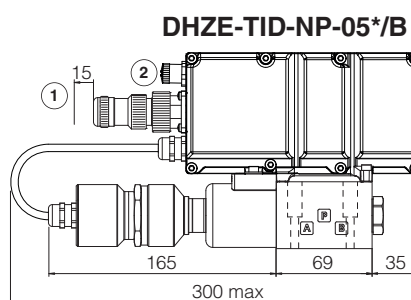
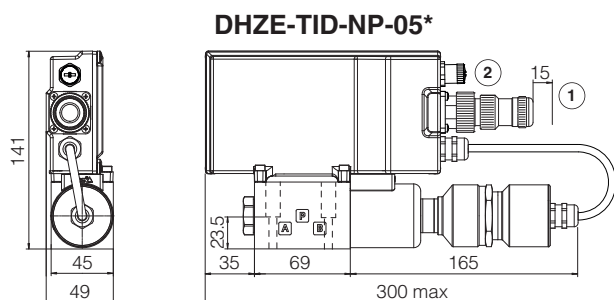

ISO 4401: 2000 (see table P005)
 Mounting surface: 4401-05-04-0-05

Valve	Mass [kg]
DKZE-15*	5,5
DKZE-17*	7,1

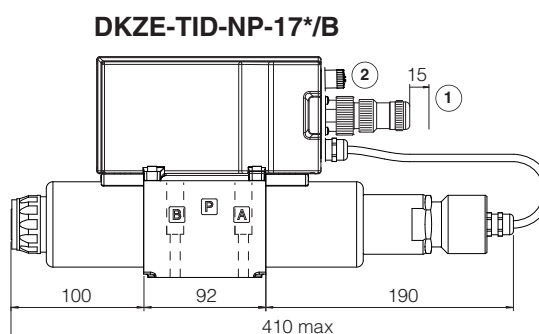
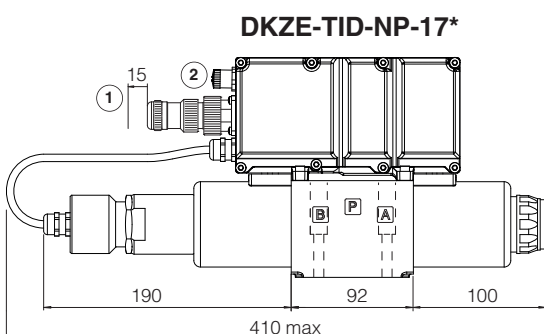
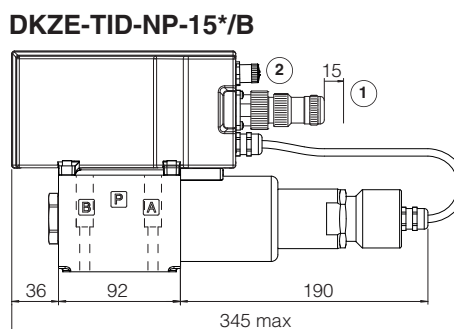
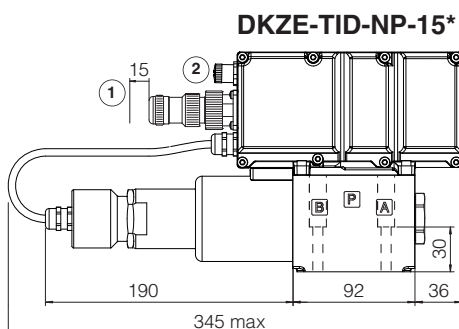

- ① = Space to remove the connectors
- ② = The dimensions of all connectors must be considered, see section 11.3

15 RELATED DOCUMENTATION

FS001	Basics for digital electrohydraulics
FS900	Operating and maintenance information for proportional valves
GS500	Programming tools
K800	Electric and electronic connectors
P005	Mounting surfaces for electrohydraulic valves