

Operating and maintenance information for ex-proof pumps

fixed and variable displacement

This operating and maintenance information apply to ATOS ex-proof pumps and is intended to provide useful guidelines to avoid risks when the pumps are installed in a system.

These norms must be strictly observed to avoid damages and to ensure trouble-free operation. The respect of these operating and maintenance norms grant an increased working life, trouble-free operation and thus reduced repairing costs.

Information and notes on the transport and storage of the pumps are also provided.

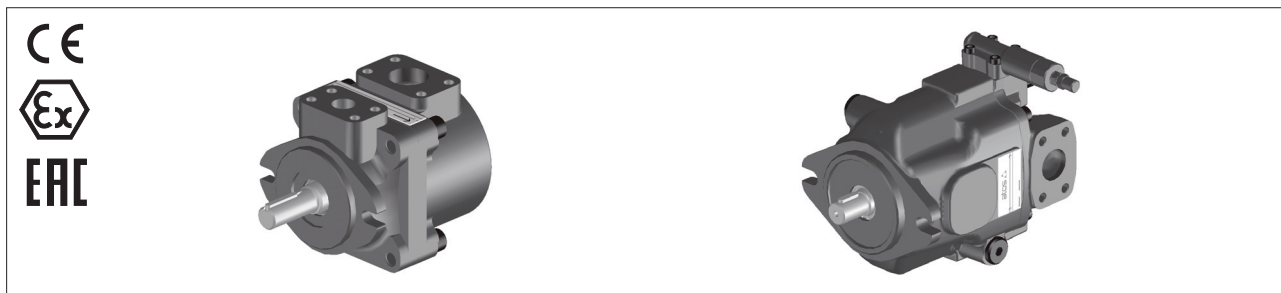

1 SYMBOLS CONVENTIONS

This symbol refers to possible dangers which can cause serious injuries

2 GENERAL NOTES

The operating and maintenance information are part of the operating instructions for the complete machine but they cannot replace them

This document is relevant to the installation, use and maintenance of ex-proof fixed displacement vane pumps and ex-proof variable displacement piston pumps for application in explosive hazardous environments.

2.1 Warranty

All the hydraulic pumps have 1 year warranty; the expiration of warranty results from the following operations:

- Unauthorized mechanical interventions
- The hydraulic pumps are not used exclusively for their intended purpose as defined in these operating and maintenance information
- Respect the working limits indicated on nameplate and on technical tables: AX010 for PFEA and AX050 for PVPCA

3 CERTIFICATIONS AND PROTECTION MODE

The ex-proof pumps subject of this operating and maintenance information are certified ATEX and EAC

They are in compliance with following protection mode:

II 2/2 G Ex h IIC T5 Gb II 2/2 D Ex h IIC T100°C Db

4 HARMONIZED STANDARDS

The Essential Health and Safety Requirements are assured by compliance to the following standards:

EN ISO 80079-36 Explosive atmospheres – Part 36: Non-electrical equipment for explosive atmospheres – Basic method and requirements

EN ISO 80079-37 Explosive atmospheres – Part 37: Non-electrical equipment for explosive atmospheres – Non electrical type of protection constructional safety “c”, control of ignition source “b”, liquid immersion “k”

The pumps may exclusively be used in areas and zones assigned to the equipments group and category. See section **6** for zones in relation to equipment groups and category.

Check the code in the nameplate to ensure that the pump is suitable for the installation area.

5 WORKING CONDITIONS

Pumps type	PFEA		PVPCA	
	STD, /PE	/7 /PE	STD, /PE	/7 /PE
Pumps version				
Ambient temperature [°C]	-20 ÷ +60	-20÷+70	-20 ÷ +60	-20÷+70
Max inlet fluid temperature [°C]	+60	+80	+60	+80
Protection degree	IP 66			
Max working pressure (1)	PFEA*-*1: from 160 to 210 bar, PFEA*-*2: from 210 to 300 bar		280 bar for size 29, 46, 73 250 bar for size 90	
Recommended pressure at inlet port	PFEA*-*1: from -0,15 to +1,5 bar for speed up to 1800 rpm; from 0 to +1,5 bar for speed over 1800 rpm PFEA*-*2: from 0 to +1,5 bar		from -0,2 to +24 bar	
Speed range (1) [rpm]	from 800 to 2800 rpm, depending to the size		from 600 to 3000 rpm, depending to the size	

(1) Max working pressure and speed range must be reduced for HFDD, HFDR and HFC fluids, see tab. **AX10** for PFEA and **AX050** for PVPCA-*

5 NAMEPLATES

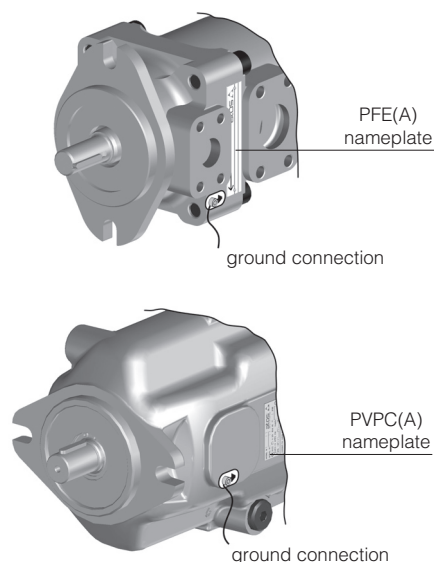

Nameplate for PFEA

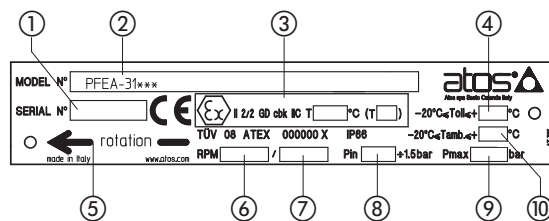

Nameplate for PVPCA

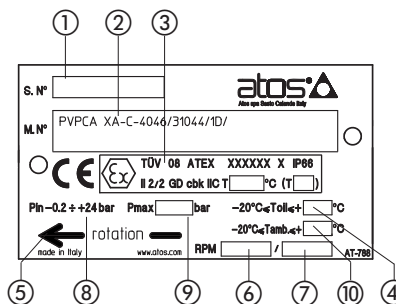

Description

- ① Serial number
- ② Pump code
- ③ Marking according to ATEX
- ④ Maximum inlet fluid temperature
- ⑤ Pump shaft rotation direction: clockwise or counterclockwise
- ⑥ Minimum pump rotation speed in RPM = revolution/min
- ⑦ Maximum pump rotation speed in RPM = revolution/min
- ⑧ Minimum inlet pressure (PFEA), range inlet pressure (PVPCA)
- ⑨ Maximum working pressure
- ⑩ Maximum ambient temperature
- ⑪ Delivery date

Ex II 2/2G Ex h IIC T(*) Gb or Ex II 2/2D Ex h IIIC T(**)°C Db

- Ex** = Equipment for explosive atmospheres
- II** = Group II for surfaces plants
- 2/2** = Pump category
- G** or **D** = **G** for gas and vapours, **D** for dust
- h** = Marking includes one or more of the following types of protection ("c", "b", "k")
- IIC** = Gas group (acetylene, hydrogen)
- IIIC** = Conductive dust
- T*** = Temperature class (T6, T5, T4)
- T**°C** = Max surface temperature (85, 100, 135)

6 EQUIPMENT GROUP, CATEGORY AND INSTALLATION ZONE

The user must define the overall areas of the system into different explosive atmospheres zones in accordance with directive 99/92/CE. The table below shows the available installation zones related to the equipment group and category.

Equipment group	Category	Application, properties	Zone
II	2/2G	Potentially explosive atmospheres, in which explosive gases, mists or vapors are likely to occur occasionally. High level of protection	1, 2
II	2/2D	Potentially explosive atmospheres, in which explosive dust/air mixtures are likely to occur occasionally. High level of protection	21, 22

PUMP VERSION	Equipment group	Category	Gas and Dust group	Temperature class	Zone
PFEA and PVPCA	II	2/2G and 2/2D	IIC and IIIC	PFEA T6 (T85°C), PVPCA T5 (T100°C)	1, 2, 21, 22
PFEA* /7 /PE and PVPCA* /7 /PE	II	2/2G and 2/2D	IIC and IIIC	PFEA* T5 (T100°C), PVPCA* T4 (T135°C)	1, 2, 21, 22

7 SAFETY NOTES

- General:

- Before start up make sure that the pump is always filled with the working fluid. See section 7.4.
- The pump must not be used with "OUT" port closed; in order to limit the maximum working pressure a relief valve must be installed on the pressure line.
- Make sure that the maximum working conditions shown in section 5 are not exceeded

7.1 Installation position and port orientation

The installation must ensure that the pump remains always filled with the working fluid.

- For **PFEA**: the pump can operate in any position, the available orientation of the oil ports is according to the below picture. In the ordering code must be specified the selected orientation.

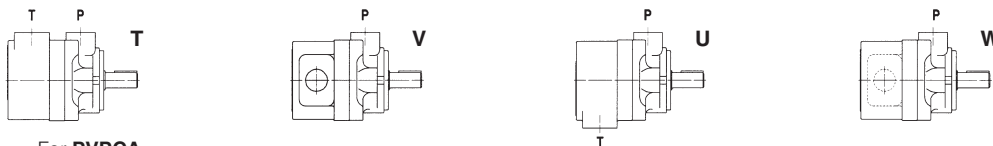

- For **PVPCA**:

- The pumps can be installed in horizontal or in vertical position. In case of vertical position the pump shaft must be oriented upward.
- The drain pipe must be oriented so that the pump body always remains filled with the fluid, specially when not working. For this reason the pump is provided with 2 drain connections located in opposite side of the body, so that, depending to the pump orientation, the optimal drain piping can be arranged
- Before the commissioning the pump body must be filled with the working fluid through one of the drain connections.
- The connection with the electric motor must be realized by means of proper elastic coupling.

7.2 Shaft loads

PFEA: axial and radial loads acting on shaft are not permitted.

PVPCA: axial and radial loads acting on shaft are permitted, max permissible loads are indicated in the table AX050, section 2.

The coupling with the electric motor must be sized to absorb the power peaks.

The coupling alignment between the motor and pump shaft must ensured

7.3 Shaft rotation

The direction of shaft rotation (D = clockwise, S = counterclockwise, viewed from the shaft end) must be the same of the arrow on the nameplate.

7.4 Oil level and temperature

Make sure that the pump is always filled with fluid. The installer / end user has to provide a level meter to verify the presence of fluid inside the tank.

The monitoring of the inlet fluid temperature it is required only when it can reach critical values.

This monitoring should be performed on the surface of the fluid inlet pipe, near the pump's suction flange.

The monitoring system must operating with a tolerance of -5 °C of the maximum declared value.

For example, if the maximum inlet fluid temperature is 60 °C, the control system must be operating between + 55 °C and + 60 °C.

The sensor used for monitoring the fluid level and the temperature must be ATEX certified and conform to the installation area: the control unit (PLC) must be certified IPL1 or SIL 1 also.

7.5 Important notes

- A pressure relief valve must be installed on the pressure line near the pump outlet port.
- The electric motor to be used for the pump operation must be also certified in compliance with installation zone. The compliance with applicable norms is extended to all electrical components connected with the installed pump.
- The piping have to be dimensioned according to the max pressure and max flow rate
- All pipes and surfaces must be cleaned from dirt before mounting
- Make sure that connections are sealed before giving pressure to the system
- Ensure to not exchange the pipe ports when connecting the system
- Ensure that the pump installation allows an easy acces for maintenance purpose
- According to EN 1127-1:2008, the maximum surface temperature indicated in the nameplate must be lower than the following Tmax values:
Gas - Tmax= max value (80% of gas ignition temperature) **Dust** - Tmax = dust ignition tempeature - 75°C
- Make sure that the pump is suitable for the use in the designated installation area, on the base of the zone classification according to the Directive 99/92/CE and to the type of flammable atmosphere (gas, vapor, dust)
- The fluid ignition temperature must be 50K greater than the maximum surface temperature indicated in the nameplate
- The maximum operating pressure and minimum inlet pressure are indicated on pump's nameplate
- The pump must be connected to ground using the ground facility (screw M3x5) provided on the pump body and evidenced with grounding nameplate
- The pump's body and the electric motor, or other devices used to drive the pump, must be connected at the same electric equipotential level
- Pumps PVPCA with control devices type CH are equipped with Explosion-proof solenoid valves (assembled to the pump body and certified according to ATEX 2014/34/EU
- Pumps PVPCA with control devices type LW are equipped with a device to achieve a constant power, factory set at a specific power value required by customer

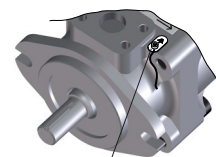

Ground connection



Grounding nameplate

7.6 Hydraulic fluids and operating viscosity range

Recommended mineral oils type HLP having high viscosity index. Ensure to use hydraulic fluids compatible with the selected seals.

The type of fluid has to be selected in consideration of the effective working temperature range, so that the fluid viscosity remains at the optimal level.

Note: for PVPCA the temperature of the fluid contained in the pump body (drain line) is always higher than the tank temperature, specially if the pump is working for long time in null flow conditions and at high pressure.

Fluid viscosity limits:

- 10 mm²/s for short periods at max fluid temperature on drain line
- 24 to 100 mm²/s during normal operation
- 1000 mm²/s for short period at cold start-up (800 mm²/sec for PVPCA)

7.7 Filtration

The correct fluid filtration ensures a long service life of the pumps and it prevent anomalous wearing or sticking.

Contamination in the hydraulic fluid may cause functional failures e.g. loss of efficiency and increased noise level.

In the worst case, this may result in heavy damages and breakages.

Ensure adequate hydraulic fluid cleanliness according to the cleanliness classes of the pumps over the entire operating range.

Max fluid contamination level:

- normal operation: **PFEA** = ISO4406 class 21/19/16 NAS1638 class 10; **PVPCA** = ISO4406 class 20/18/15 NAS1638 class 9
- longer life: **PFEA** = ISO4406 class 19/17/14 NAS1638 class 8; **PVPCA** = ISO4406 class 18/16/13 NAS1638 class 7

Note: see also filter section at www.atos.com or KTF catalog

8 MAINTENANCE



Maintenance must be carried out only by qualified personnel with a specific knowledge of hydraulics and electrohydraulics.

8.1 Ordinary Maintenance

- Service work performed on the valve by end user or not qualified personnel invalidates the certification
 - Cleaning the external surfaces using a wet cloth to avoid accumulation of dust layer over 5 mm
 - Don't use compressed air for cleaning to avoid any dangerous dust dispersion on the surrounding atmosphere
 - Any sudden increment in temperature requires the immediate stop of the system and the inspection of the relevant components
 - The pump does not require other maintenance operations except for bearing and front shaft seal, according to the following schedule:
 - PFEA must be replaced after reaching **20000 working hours**
 - PVPCA without radial loads must be replaced after reaching **20000 working hours**
- In presence of radial loads (permitted only for PVPCA) the following maintenance schedule must be considered:
- PVPCA-3029 must be replaced after reaching **1550 working hours**
 - PVPCA-4046 must be replaced after reaching **2600 working hours**
 - PVPCA-5073 must be replaced after reaching **5000 working hours**
 - PVPCA-5090 must be replaced after reaching **5000 working hours**
- When mounting bearings and front seal, observe the correct position as indicated in the drawing below: any incorrect positioning can result in oil leakages
 - Results of maintenance and inspection must be planned and documented
 - Follow the maintenance instructions of the fluid manufacturer

- ① Front seal
- ② Bearings

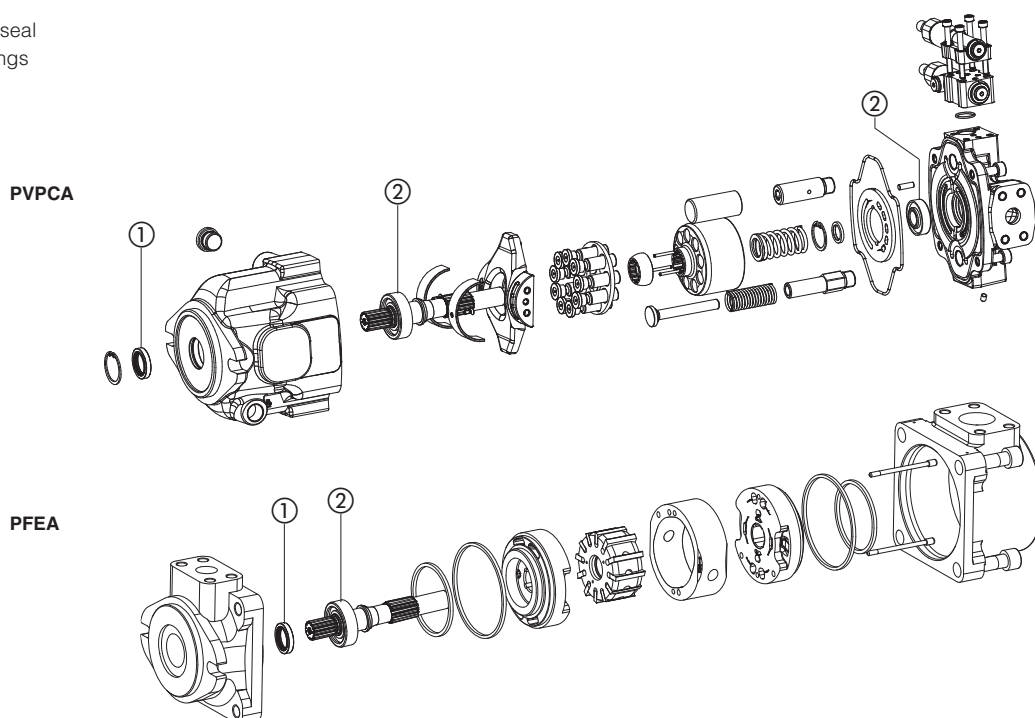

8.2 Repairing

Before beginning any repairing activity, the following guidelines must be observed:

- Unauthorized opening of the pump during the warranty period invalidates the warranty
- Be sure to use only original spare parts manufactured or supplied by ATOS factory
- Provide all the required tools to make the repair operations safely and to don't damage the components

9 TRANSPORT AND STORAGE

9.1 Transport

Observe the following guidelines for transportation of pumps:

- Hydraulic pumps should be transported using a forklift or a lifting gear ensuring a stable position of the pump
- Use soft lifting belts to move or lift the pumps in order to avoid damages
- Before any movement check the pumps weight specified in the relevant technical tables AX010 and AX050

9.2 Storage

PFEA corrosion protection is achieved with zinc phosphating; this treatment protect the pump to grant a storage period up to 12 months.

PVPCA corrosion protection is achieved with transparent oil film.

Additionally all pumps are tested with mineral oil OSO 46; the oil film left after testing ensure the internal corrosion protection.



In case of storage period longer than 12 months please contact our technical office.

Ensure that pumps are well protected against water and humidity in case of a storage in the open air.