

Proportional relief valves

piloted, without transducer

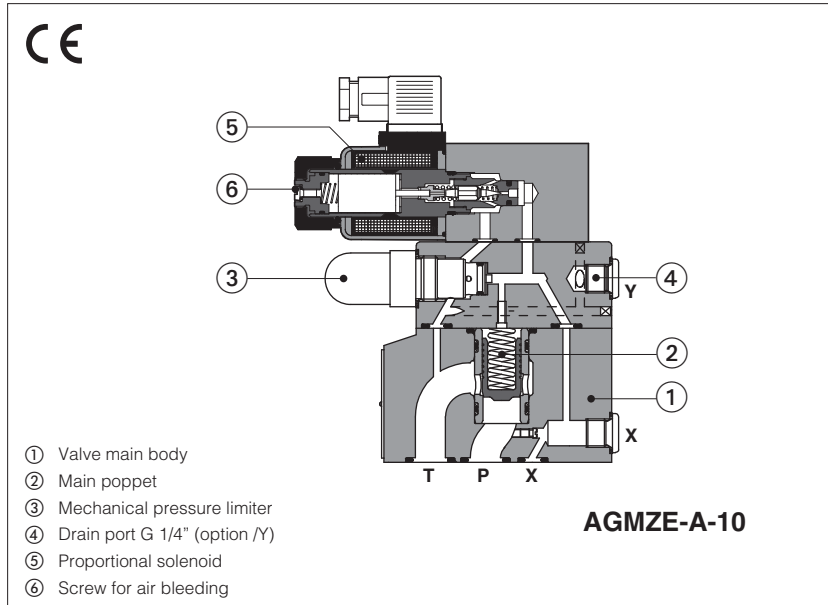

AGMZE-A

Poppet type, piloted, proportional pressure relief valves for open loop pressure controls. They operate in association with off-board driver, which supply the proportional valves with proper current to align the valve regulation to the reference signal supplied to the driver.

The solenoids are certified according to North American standard **cURus**.

Size: **10, 20, 32** - ISO 6264
 Max flow: **200, 400, 600 l/min**
 Max pressure: **350 bar**

1 MODEL CODE

AGMZE	-	A	-	10	/	315	/	*	-	*	/	*	/	*	/	*
Proportional pressure relief valve, piloted																
A = for off-board driver, see section 3																
Valve size ISO 6264: 10, 20, 32																
Max regulated pressure: 50 = 50 bar 210 = 210 bar 350 = 350 bar 100 = 100 bar 315 = 315 bar																
Hydraulic options (1): E = external pilot Y = external drain (only pipe connection G 1/4")																
Seals material, see section 8: - = NBR PE = FKM BT = HNBR																
Series number																
Coil voltage, see section 12: - = standard coil for 24 Vdc Atos drivers 6 = optional coil for 12 Vdc Atos drivers 18 = optional coil for low current drivers (2)																
Coil with special connectors, see section 16: - = omit for standard DIN connector J = AMP Junior Timer connector K = Deutsch connector S = Lead Wire connection																

(1) Possible combined options: /EY

(2) Select valve's coil voltage /18 in case of electronic drivers not supplied by Atos, with power supply 24 VDC and with max current limited to 1A

2 HYDRAULIC SYMBOL

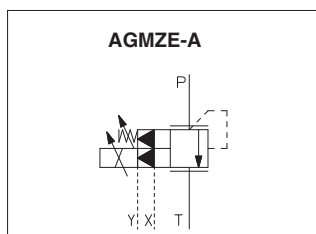

3 OFF-BOARD ELECTRONIC DRIVERS

Drivers model	E-MI-AC-01F		E-MI-AS-IR		E-BM-AS-PS		E-BM-AES
Type	Analog		Digital				
Voltage supply (Vdc)	12	24	12	24	12	24	24
Valve coil option	/6	std	/6	std	/6	std	std
Format	plug-in to solenoid				DIN-rail panel		
Tech table	G010		G020		G030		GS050

4 GENERAL NOTES

Atos digital proportionals valves are CE marked according to the applicable directives (e.g. Immunity and Emission EMC Directive). Installation, wirings and start-up procedures must be performed according to the general prescriptions shown in tech table **FS900** and in the installation notes supply with relevant components.

5 GENERAL CHARACTERISTICS

Assembly position	Any position		
Subplate surface finishing to ISO 4401	Acceptable roughness index: Ra ≤ 0,8, recommended Ra 0,4 – Flatness ratio 0,01/100		
MTTFd valves according to EN ISO 13849	75 years, see technical table P007		
Ambient temperature range	Standard = -20°C ÷ +70°C	/PE option = -20°C ÷ +70°C	/BT option = -40°C ÷ +60°C
Storage temperature range	Standard = -20°C ÷ +80°C	/PE option = -20°C ÷ +80°C	/BT option = -40°C ÷ +70°C
Surface protection	Zinc coating with black passivation		
Corrosion resistance	Salt spray test (EN ISO 9227) > 200 h		
Conformity	CE according to EMC directive 2014/30/EU (Immunity: EN 61000-6-2; Emission: EN 61000-6-3) RoHS Directive 2011/65/EU as last update by 2015/863/EU REACH Regulation (EC) n°1907/2006		

6 HYDRAULIC CHARACTERISTICS

Valve model	AGMZE-A-10	AGMZE-A-20	AGMZE-A-32
Max regulated pressure [bar]	50; 100; 210; 315; 350		
Max pressure at port P [bar]	350		
Max pressure at port T [bar]	210		
Min regulated pressure [bar]	see min. pressure / flow diagrams at section 11		
Max flow [l/min]	200	400	600
Response time 0-100% step signal (depending on installation) (1) [ms]	≤ 120	≤ 135	≤ 150
Hysteresis	≤ 2 [% of max pressure]		
Linearity	≤ 3 [% of max pressure]		
Repeatability	≤ 2 [% of max pressure]		

Note: above performance data refer to valves coupled with Atos electronic drivers, see section 3

(1) Average response time values; the pressure variation in consequence of a modification of the reference input signal to the valve is affected by the stiffness of the hydraulic circuit: greater is the stiffness of the circuit, faster is the dynamic response

7 ELECTRICAL CHARACTERISTICS

Power supplies	Nominal : +24 VDC Rectified and filtered : VRMS = 20 ÷ 32 VMAX (ripple max 10 % VPP)		
Coil voltage code	standard	option /6	option /18
Max. solenoid current	2,5 A	3 A	1,2 A
Coil resistance R at 20°C	3,1 Ω	2,1 Ω	13,1 Ω
Insulation class	H (180°) Due to the occurring surface temperatures of the solenoid coils, the European standards ISO 13732-1 and EN982 must be taken into account		
Protection degree to DIN EN60529	IP65 with mating connectors		
Duty factor	Continuous rating (ED=100%)		
Certification	cURus North American Standard		

8 SEALS AND HYDRAULIC FLUIDS - for other fluids not included in below table, consult our technical office

Seals, recommended fluid temperature	NBR seals (standard) = -20°C ÷ +80°C, with HFC hydraulic fluids = -20°C ÷ +50°C FKM seals (/PE option) = -20°C ÷ +80°C HNBR seals (/BT option) = -40°C ÷ +60°C, with HFC hydraulic fluids = -40°C ÷ +50°C		
Recommended viscosity	20 ÷ 100 mm²/s - max allowed range 15 ÷ 380 mm²/s		
Max fluid contamination level	normal operation	ISO4406 class 18/16/13 NAS1638 class 7	see also filter section at
	longer life	ISO4406 class 16/14/11 NAS1638 class 5	www.atos.com or KTF catalog
Hydraulic fluid	Suitable seals type	Classification	Ref. Standard
Mineral oils	NBR, FKM, HNBR	HL, HLP, HLPD, HVLP, HVLPD	DIN 51524
Flame resistant without water	FKM	HFDD, HFDR	ISO 12922
Flame resistant with water	NBR, HNBR	HFC	

9 DIAGRAMS (based on mineral oil ISO VG 46 at 50 °C)

1 = Regulation diagrams
with flow rate Q = 50 l/min

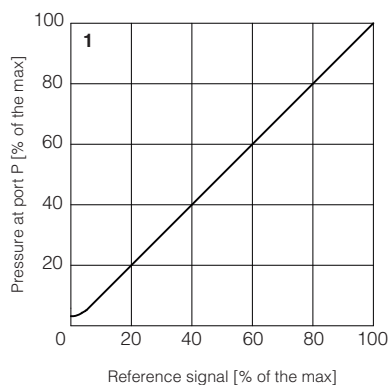

2 = Pressure/flow diagrams
with reference signal set at Q = 50 l/min

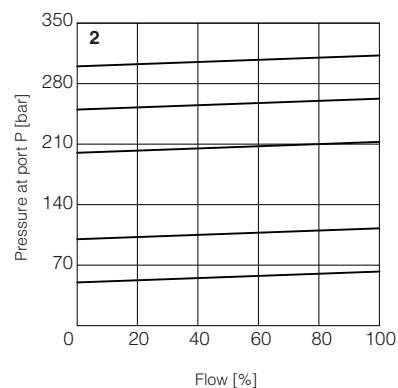

3-8 = Min. pressure/flow diagrams
with zero reference signal

- 3 = AGMZE-A-10/50, 100, 210, 315
- 4 = AGMZE-A-10/350
- 5 = AGMZE-A-20/50, 100, 210, 315
- 6 = AGMZE-A-20/350
- 7 = AGMZE-A-32/50, 100, 210, 315
- 8 = AGMZE-A-32/350

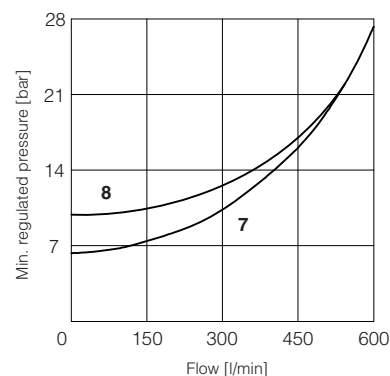
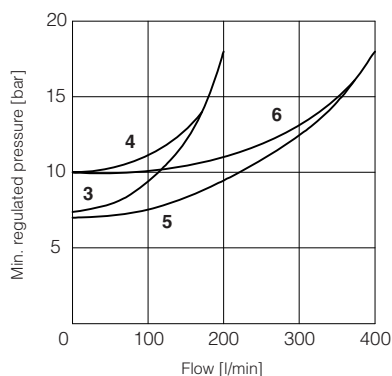

10 HYDRAULIC OPTIONS

E = External pilot option to be selected when the pilot pressure is supplied from a different line respect to the P main line.
With option E the internal connection between port P and X of the valve is plugged.
The pilot pressure must be connected to the X port available on the valve's mounting surface or on main body (threaded pipe connection G 1/4").

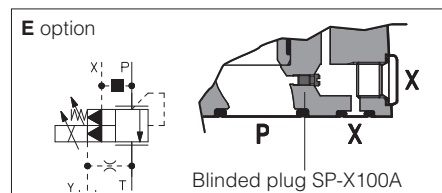

Y = The external drain is mandatory in case the main line T is subjected to pressure peaks or it is pressurized.
The Y drain port has a threaded connection G 1/4" available on the pilot stage body.

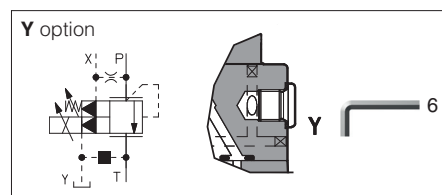

11 POSSIBLE COMBINED OPTIONS

/EY

12 COIL VOLTAGE OPTIONS

6 = Optional coil to be used with Atos drivers with power supply 12 VDC.

18 = Optional coil to be used with electronic drivers not supplied by Atos, with power supply 24 VDC and with max current limited to 1A.

13 MECHANICAL PRESSURE LIMITER

The AGMZE are provided with mechanical pressure limiter acting as protection against overpressure. For safety reasons the factory setting of the mechanical pressure limiter is fully unloaded (min pressure). At the first commissioning it must be set at a value lightly higher than the max pressure regulated with the proportional control.

For the pressure setting of the mechanical pressure limiter, proceed according to following steps:

- apply the max reference input signal to the valve's driver. The system pressure will not increase until the mechanical pressure limiter remains unloaded.
- turn clockwise the adjustment screw ① until the system pressure will increase up to a stable value corresponding to the pressure setpoint at max reference input signal.
- turn clockwise the adjustment screw ① of additional 1 or 2 turns to ensure that the mechanical pressure limiter remains closed during the proportional valve working.

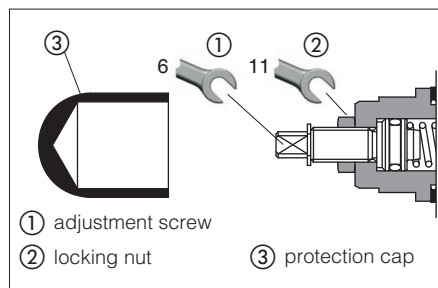

14 REMOTE PRESSURE UNLOADING

The **P** main line can be remotely unloaded by connecting the valve X port to a solenoid valve as shown in the below scheme (venting valve).

This function can be used in emergency to unload the system pressure by-passing the proportional control.

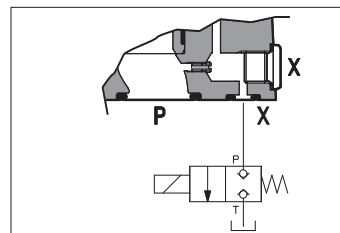

15 AIR BLEEDING

At the first valve commissioning the air eventually trapped inside the solenoid must be bled-off through the screw ① located at the rear side of the solenoid housing.

The presence of air may cause pressure instability and vibrations.

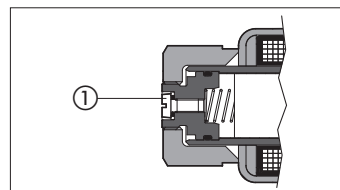

16 COILS WITH SPECIAL CONNECTORS

J option

Coil type COZEJ
AMP Junior Timer connector
Protection degree IP67

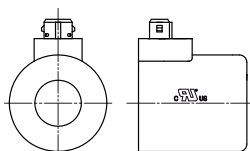

K option

Coil type COZEK
Deutsch connector, DT-04-2P male
Protection degree IP67

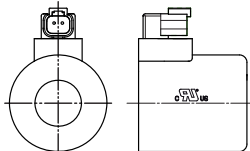

S option

Coil type COZES
Lead Wire connection
Cable length = 180 mm

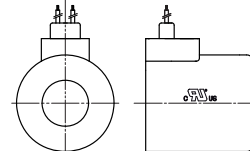

17 SOLENOID CONNECTION

PIN	SIGNAL	TECHNICAL SPECIFICATION	Connector code 666
1	COIL	Power supply	
2	COIL	Power supply	
3	GND	Ground	

18 FASTENING BOLTS AND SEALS

	AGMZE-A-10	AGMZE-A-20	AGMZE-A-32
	Fastening bolts: 4 socket head screws M12x35 class 12.9 Tightening torque = 125 Nm	Fastening bolts: 4 socket head screws M16x50 class 12.9 Tightening torque = 300 Nm	Fastening bolts: 4 socket head screws M20x60 class 12.9 Tightening torque = 600 Nm
	Seals: 2 OR 123 Diameter of ports P, T: Ø 14 mm 1 OR 109/70 Diameter of port X: Ø 3,2 mm	Seals: 2 OR 4112 Diameter of ports P, T: Ø 24 mm 1 OR 109/70 Diameter of port X: Ø 3,2 mm	Seals: 2 OR 4131 Diameter of ports P, T: Ø 28 mm 1 OR 109/70 Diameter of port X: Ø 3,2 mm

SIZE 10

ISO 6264: 2007

Mounting surface: 6264-06-09-1-97
(see table P005)

Mass [kg]	
AGMZE-A-10	5,4

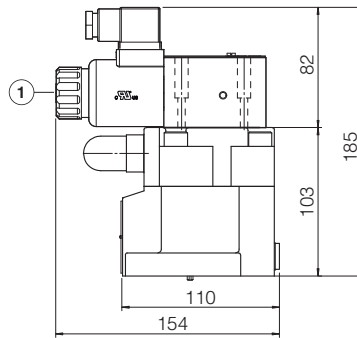

AGMZE-A-10

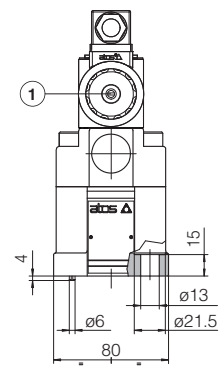

SIZE 20

ISO 6264: 2007

Mounting surface: 6264-08-13-1-97
(see table P005)

Mass [kg]	
AGMZE-A-20	6,6

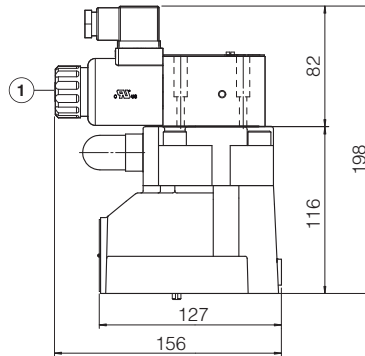

AGMZE-A-20

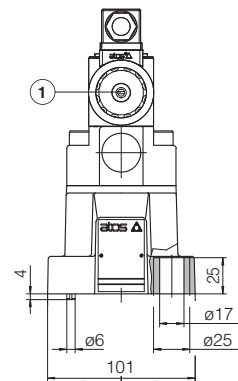

SIZE 32

ISO 6264: 2007

Mounting surface: 6264-10-17-1-97
(see table P005)

(with M20 fixing holes instead of standard M18)

Mass [kg]	
AGMZE-A-32	8

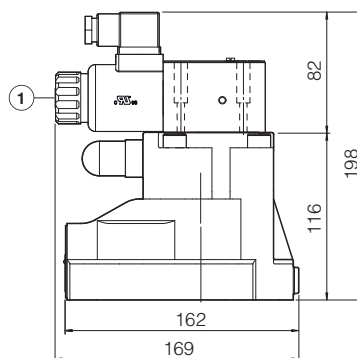

AGMZE-A-32

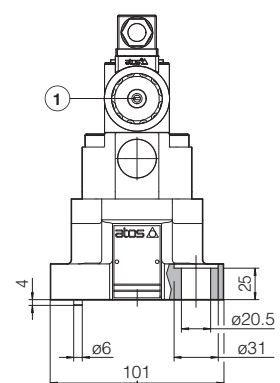

① = Air bleeding, see section 15 

20 RELATED DOCUMENTATION

FS001	Basics for digital electrohydraulics	GS050	E-BM-AES digital driver
FS900	Operating and maintenance information for proportional valves	GS500	Programming tools
G010	E-MI-AC analog driver	K800	Electric and electronic connectors
G020	E-MI-AS-IR digital driver	P005	Mounting surfaces for electrohydraulic valves
G030	E-BM-AS digital driver		