

# Digital proportional directional valves

direct, without transducer, with positive spool overlap

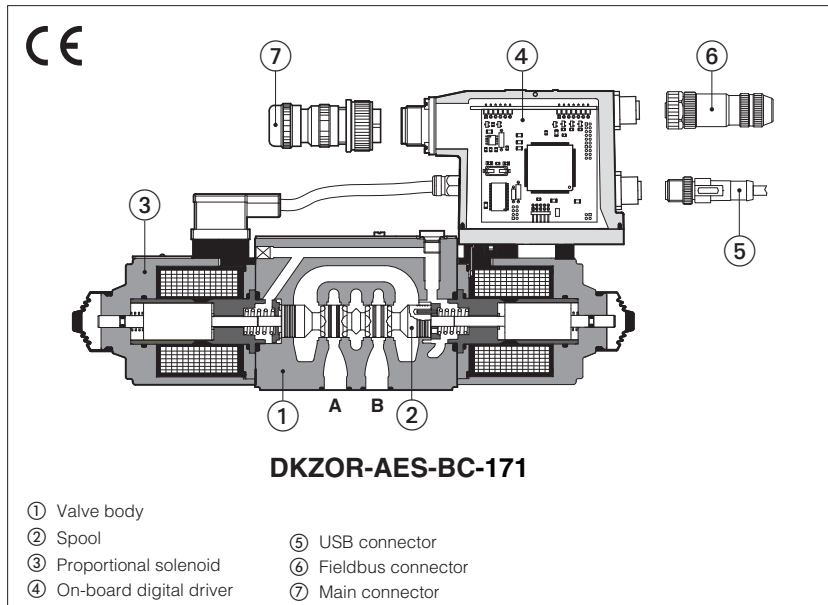

## DHZO-A, DHZO-AEB, DHZO-AES DKZOR-A, DKZOR-AEB, DKZOR-AES

Digital proportional valves without position transducer and with positive spool overlap, for open loop directional controls and not compensated flow regulations.

**A** to be coupled with off-board drivers.

**AEB** basic execution, with on-board digital driver, analog reference signals and USB port for software functional parameters setting.

**AES** full execution, with on-board digital driver which includes also fieldbus interface for functional parameters setting, reference signals and real-time diagnostics.

**DHZO:** Size: **06** - ISO 4401 Max flow: **70 l/min** Max pressure: **350 bar**  
**DKZOR:** Size: **10** - ISO 4401 Max flow: **160 l/min** Max pressure: **315 bar**

### 1 MODEL CODE for STANDARD SPOOLS

|  |   |  |   |           |   |          |           |   |          |          |   |   |   |   |   |   |
|--|---|--|---|-----------|---|----------|-----------|---|----------|----------|---|---|---|---|---|---|
| <b>DHZO</b>  | - | <b>AES</b>   | - | <b>BP</b> | - | <b>0</b> | <b>71</b> | - | <b>L</b> | <b>5</b> | / | * | / | * | / | * |
| <p><b>DHZO</b> = size 06<br/><b>DKZOR</b> = size 10</p>  |   | <p><b>A</b> = for off-board driver, see section 2<br/> <b>AEB</b> = basic on-board digital driver (1)<br/> <b>AES</b> = full on-board digital driver (2)</p> |   |           |   |          |           |   |          |          |   |   |   |   |   |   |
| <p><b>Fieldbus interfaces</b>, USB port always present (3):<br/> <b>NP</b> = Not present      <b>BC</b> = CANopen<br/> <b>BP</b> = PROFIBUS DP      <b>EH</b> = EtherCAT</p> |   | <p><b>Seals material</b>, see section 9:<br/> - = NBR<br/> <b>PE</b> = FKM<br/> <b>BT</b> = HNBR</p>   |   |           |   |          |           |   |          |          |   |   |   |   |   |   |
| <p><b>Valve size</b> ISO 4401:<br/> <b>0</b> = 06    <b>1</b> = 10</p>   |   | <p>Series number</p>   |   |           |   |          |           |   |          |          |   |   |   |   |   |   |

**Fieldbus interfaces**, USB port always present (3):  
**NP** = Not present      **BC** = CANopen  
**BP** = PROFIBUS DP      **EH** = EtherCAT

#### Configuration (4):

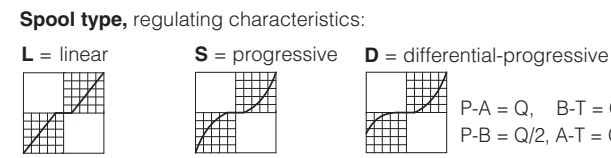
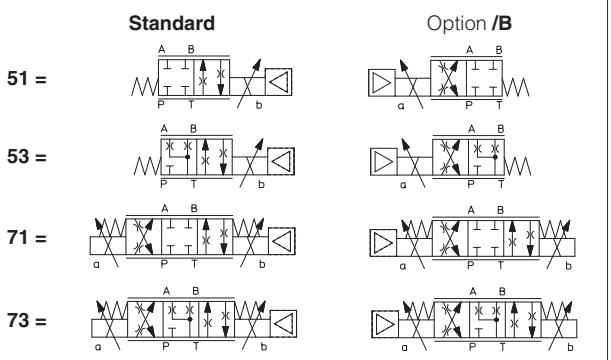

#### Hydraulic options (5):

**B** = solenoid and on-board digital driver at side of port A  
**Y** = external drain

#### Hand lever options, only for A:

**MO** = horizontal hand lever  
**MV** = vertical hand lever  
**BMO** = horizontal hand lever installed at side of port A  
**BMV** = vertical hand lever installed at side of port A

#### Electronic options, only for AEB and AES (5):

**C** = current feedback for pressure transducer 4 ÷ 20 mA (omit for std voltage 0 ÷ 10 VDC) - only for **W**  
**I** = current reference input 4 ÷ 20 mA (omit for std voltage ±10 VDC)  
**Q** = enable signal  
**Z** = double power supply, enable, fault and monitor signals - 12 pin connector  
**W** = power limitation function - 12 pin connector

|                                      |               |              |              |                  |                  |
|--------------------------------------|---------------|--------------|--------------|------------------|------------------|
| <b>Spool size:</b>                   | <b>14</b> (L) | <b>1</b> (L) | <b>2</b> (S) | <b>3</b> (L,S,D) | <b>5</b> (L,S,D) |
| DHZO =                               | 1             | 4,5          | 8            | 18               | 28               |
| DKZOR =                              | -             | -            | -            | 45               | 60               |
| Nominal flow (l/min) at Δp 10bar P-T |               |              |              |                  |                  |

(1) Only for **NP**  
(2) Only for **BC, BP, EH**  
(3) Omit for **A** execution  
(4) Hydraulic symbols are represented with on-board digital driver  
(5) For possible combined options, see section 13

## 2 OFF-BOARD ELECTRONIC DRIVERS - only for A

| Drivers model        | E-MI-AC-01F         |     | E-MI-AS-IR |     | E-BM-AS-PS     |     | E-BM-AES |
|----------------------|---------------------|-----|------------|-----|----------------|-----|----------|
| Type                 | Analog              |     |            |     | Digital        |     |          |
| Voltage supply (VDC) | 12                  | 24  | 12         | 24  | 12             | 24  | 24       |
| Valve coil option    | /6                  | std | /6         | std | /6             | std | std      |
| Format               | plug-in to solenoid |     |            |     | DIN-rail panel |     |          |
| Data sheet           | G010                |     | G020       |     | G030           |     | GS050    |

## 3 GENERAL NOTES

Atos digital proportionals valves are CE marked according to the applicable directives (e.g. Immunity and Emission EMC Directive). Installation, wirings and start-up procedures must be performed according to the general prescriptions shown in tech table **FS900** and in the user manuals included in the E-SW-\* programming software.

## 4 VALVE SETTINGS AND PROGRAMMING TOOLS

Valve's functional parameters and configurations, can be easily set and optimized using Atos E-SW programming software connected via USB port to the digital driver. For fieldbus versions, the software permits valve's parameterization through USB port also if the driver is connected to the central machine unit via fieldbus.

The software is available in different versions according to the driver's options (see table **GS500**):

|                      |   |                  |               |
|----------------------|---|------------------|---------------|
| <b>E-SW-BASIC</b>    | support: NP (USB)   | PS (Serial)      | IR (Infrared) |
| <b>E-SW-FIELDBUS</b> | support: BC (CANopen)   | BP (PROFIBUS DP) | EH (EtherCAT) |
|                      | EW (POWERLINK)  | EI (EtherNet/IP) | EP (PROFINET) |
| <b>E-SW-*/PQ</b>     | support: valves with SP, SF, SL alternated control (e.g. E-SW-BASIC/PQ) |                  |               |



**WARNING: drivers USB port is not isolated!** For E-C-SB-USB/M12 cable, the use of isolator adapter is highly recommended for PC protection



**WARNING:** see tech table **GS500** for the list of countries where the Bluetooth adapter has been approved

## USB or Bluetooth connection

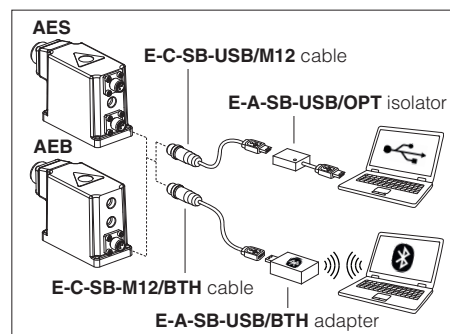

## 5 FIELDBUS - only for AES, see tech. table GS510

Fieldbus allows valve direct communication with machine control unit for digital reference, valve diagnostics and settings. These execution allow to operate the valves through fieldbus or analog signals available on the main connector.

## 6 GENERAL CHARACTERISTICS

|  |   |
|--|---|
| Assembly position                      | Any position  |
| Subplate surface finishing to ISO 4401 | Acceptable roughness index: Ra ≤ 0,8, recommended Ra 0,4 – Flatness ratio 0,01/100  |
| MTTFd valves according to EN ISO 13849 | 150 years, see technical table P007   |
| Ambient temperature range              | <b>A:</b> Standard = -20°C ÷ +70°C /PE option = -20°C ÷ +70°C /BT option = -40°C ÷ +60°C<br><b>AEB, AES:</b> Standard = -20°C ÷ +60°C /PE option = -20°C ÷ +60°C /BT option = -40°C ÷ +60°C |
| Storage temperature range              | <b>A:</b> Standard = -20°C ÷ +80°C /PE option = -20°C ÷ +80°C /BT option = -40°C ÷ +70°C<br><b>AEB, AES:</b> Standard = -20°C ÷ +70°C /PE option = -20°C ÷ +70°C /BT option = -40°C ÷ +70°C |
| Surface protection                     | Zinc coating with black passivation, galvanic treatment (driver housing for AEB and AES)  |
| Corrosion resistance                   | Salt spray test (EN ISO 9227) > 200 h   |
| Compliance                             | CE according to EMC directive 2014/30/EU (Immunity: EN 61000-6-2; Emission: EN 61000-6-3)<br>RoHS Directive 2011/65/EU as last update by 2015/863/EU<br>REACH Regulation (EC) n°1907/2006   |

## 7 HYDRAULIC CHARACTERISTICS - based on mineral oil ISO VG 46 at 50 °C

| Valve model                        | DHZO  |     |    |            |            | DKZOR   |            |
|------------------------------------|---|-----|----|------------|------------|---|------------|
|                                    | ports P, A, B = 350;<br>T = 210 (250 with external drain /Y) Y = 10 |     |    |            |            | ports P, A, B = 315;<br>T = 210 (250 with external drain /Y) Y = 10 |            |
| Pressure limits [bar]              | L14   | L1  | S2 | L3, S3, D3 | L5, S5, D5 | L3, S3, D3  | L5, S5, D5 |
| Nominal flow Δp P-T [l/min]<br>(1) |   |     |    |            |            |   |            |
| Δp= 10 bar                         | 1   | 4,5 | 8  | 18         | 28         | 45  | 60         |
| Δp= 30 bar                         | 1,7   | 8   | 14 | 30         | 50         | 80  | 105        |
| Δp= 70 bar                         | 2,6   | 12  | 21 | 45         | 70         | 120   | 160        |
| Max permissible flow (2)           | 4   | 18  | 30 | 50         | 70         | 120   | 160        |
| Leakage [cm³/min]                  | <30 (at p = 100 bar); <135 (at p = 350 bar)                         |     |    |            |            | <80 (at p = 100 bar); <600 (at p = 315 bar)                         |            |
| Response time (3) [ms]             | ≤ 30  |     |    |            |            | ≤ 40  |            |
| Hysteresis                         | ≤ 5 [% of max regulation]   |     |    |            |            |   |            |
| Repeatability                      | ± 1 [% of max regulation]   |     |    |            |            |   |            |

**Note:** above performance data refer to valves coupled with Atos electronic drivers, see section 2

(1) For different Δp, the max flow is in accordance to the diagrams in section 10.2

(2) See detailed diagrams in section 10.3

(3) 0-100% step signal, see detailed diagrams in section 10.4

## 8 ELECTRICAL CHARACTERISTICS

|   |  |                                   |                                   |  |             |                        |
|---|--|-----------------------------------|-----------------------------------|--|-------------|------------------------|
| Power supplies  | Nominal : +24 VDC<br>Rectified and filtered : VRMS = 20 ÷ 32 VMAX (ripple max 10 % VPP)  |                                   |                                   |  |             |                        |
| Max power consumption                                 | <b>DHZO</b>  |                                   |                                   | <b>DKZOR</b>   |             |                        |
|   | <b>A = 30 W</b>  |                                   | <b>AEB, AES = 50 W</b>            | <b>A = 35 W</b>  |             | <b>AEB, AES = 50 W</b> |
| Coil voltage code                                     | standard   | option /6                         | option /18                        | standard   | option /6   | option /18             |
| Max. solenoid current                                 | 2,2 A  | 2,75 A                            | 1 A                               | 2,6 A  | 3,25 A      | 1,2 A                  |
| Coil resistance R at 20°C                             | 3 ÷ 3,3 Ω  | 2 ÷ 2,2 Ω                         | 13 ÷ 13,4 Ω                       | 3,8 ÷ 4,1 Ω  | 2,2 ÷ 2,4 Ω | 12 ÷ 12,5 Ω            |
| Analog input signals                                  | Voltage: range ±10 VDC (24 VMAX tollerant)<br>Current: range ±20 mA  |                                   |                                   | Input impedance: Ri > 50 kΩ<br>Input impedance: Ri = 500 Ω |             |                        |
| Monitor output  | Output range: voltage ±5 Vdc @ max 5 mA  |                                   |                                   |  |             |                        |
| Enable input  | Range: 0 ÷ 9 Vdc (OFF state), 15 ÷ 24 Vdc (ON state), 9 ÷ 15 Vdc (not accepted); Input impedance: Ri > 87 kΩ   |                                   |                                   |  |             |                        |
| Fault output  | Output range : 0 ÷ 24 Vdc (ON state ≡ VL+ [logic power supply] ; OFF state ≡ 0 V) @ max 50 mA;<br>external negative voltage not allowed (e.g. due to inductive loads)                              |                                   |                                   |  |             |                        |
| Pressure transducer power supply (only for /W option) | +24VDC @ max 100 mA (E-ATR-8 see tech table <b>GS465</b> )   |                                   |                                   |  |             |                        |
| Alarms  | Solenoid not connected/short circuit, cable break with current reference signal, over/under temperature, current control monitoring, power supplies level, pressure transducer failure (/W option) |                                   |                                   |  |             |                        |
| Insulation class                                      | H (180°) Due to the occuring surface temperatures of the solenoid coils, the European standards ISO 13732-1 and EN982 must be taken into account   |                                   |                                   |  |             |                        |
| Protection degree to DIN EN60529                      | <b>A</b> = IP65; <b>AEB, AES</b> = IP66 / IP67 with mating connectors  |                                   |                                   |  |             |                        |
| Duty factor   | Continuous rating (ED=100%)  |                                   |                                   |  |             |                        |
| Tropicalization                                       | Tropical coating on electronics PCB  |                                   |                                   |  |             |                        |
| Additional characteristics                            | Short circuit protection of solenoid's current supply; current control by P.I.D. with rapid solenoid switching; protection against reverse polarity of power supply                                |                                   |                                   |  |             |                        |
| Communication interface                               | USB<br>Atos ASCII coding   | CANopen<br>EN50325-4 + DS408      | PROFIBUS DP<br>EN50170-2/IEC61158 | EtherCAT<br>EC 61158                                       |             |                        |
| Communication physical layer                          | not insulated<br>USB 2.0 + USB OTG   | optical insulated<br>CAN ISO11898 | optical insulated<br>RS485        | Fast Ethernet, insulated<br>100 Base TX                    |             |                        |
| Recommended wiring cable                              | LiYCY shielded cables, see section <a href="#">17</a>  |                                   |                                   |  |             |                        |

**Note:** a maximum time of 500 ms (depending on communication type) have be considered between the driver energizing with the 24 V<sub>DC</sub> power supply and when the valve is ready to operate. During this time the current to the valve coils is switched to zero.

## 9 SEALS AND HYDRAULIC FLUIDS - for other fluids not included in below table, consult our technical office

|                                      |   |  |                      |
|--------------------------------------|---|--|----------------------|
| Seals, recommended fluid temperature | NBR seals (standard) = -20°C ÷ +60°C (+80°C for <b>A</b> ), with HFC hydraulic fluids = -20°C ÷ +50°C<br>FKM seals (/PE option) = -20°C ÷ +80°C<br>HNBR seals (/BT option) = -40°C ÷ +60°C, with HFC hydraulic fluids = -40°C ÷ +50°C |  |                      |
| Recommended viscosity                | 20 ÷ 100 mm <sup>2</sup> /s - max allowed range 15 ÷ 380 mm <sup>2</sup> /s   |  |                      |
| Max fluid contamination level        | normal operation  | ISO4406 class 18/16/13   | NAS1638 class 7      |
|                                      | longer life   | ISO4406 class 16/14/11   | NAS1638 class 5      |
|                                      |   | see also filter section at <a href="http://www.atos.com">www.atos.com</a> or KTF catalog |                      |
| <b>Hydraulic fluid</b>               | <b>Suitable seals type</b>  | <b>Classification</b>  | <b>Ref. Standard</b> |
| Mineral oils                         | NBR, FKM, HNBR  | HL, HLP, HLPD, HVLP, HVLPD   | DIN 51524            |
| Flame resistant without water        | FKM   | HFDU, HFDR   | ISO 12922            |
| Flame resistant with water           | NBR, HNBR   | HFC  |                      |

**10 DIAGRAMS** - based on mineral oil ISO VG 46 at 50 °C

**10.1 Regulation diagrams** - values measure at  $\Delta p$  30 bar P-T

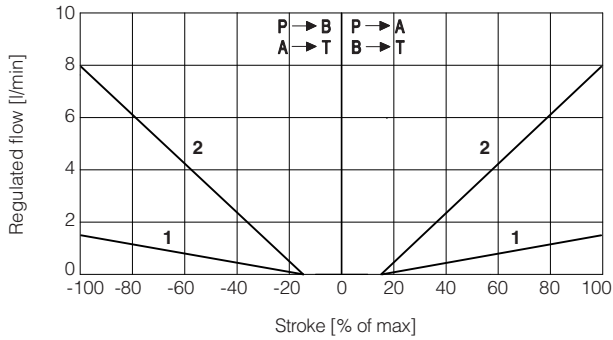

**DHZO**  
1 = L14 2 = L1

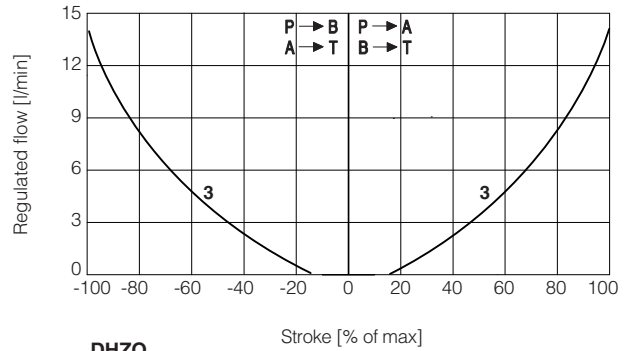

**DHZO**  
3 = S2

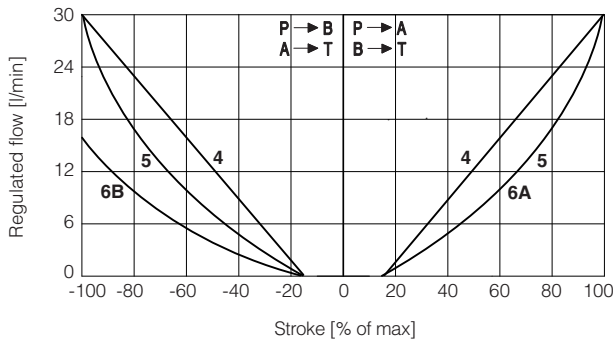

**DHZO**  
4 = L3 5 = S3  
6A = D3 (P → A, A → T)  
6B = D3 (P → B, B → T)

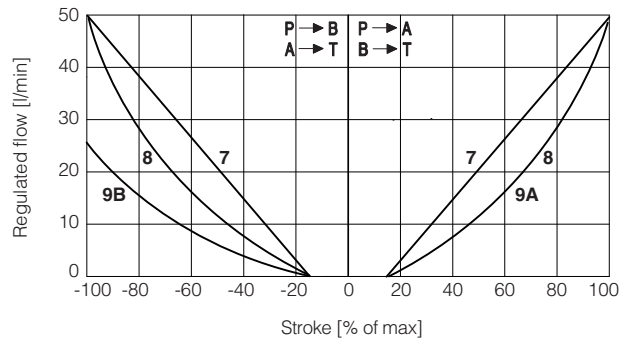

**DHZO**  
7 = L5 8 = S5  
9A = D5 (P → A, A → T)  
9B = D5 (P → B, B → T)

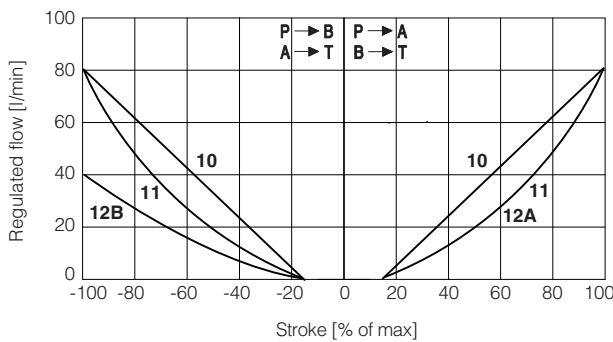

**DKZOR**  
10 = L3 11 = S3  
12A = D3 (P → A, A → T)  
12B = D3 (P → B, B → T)

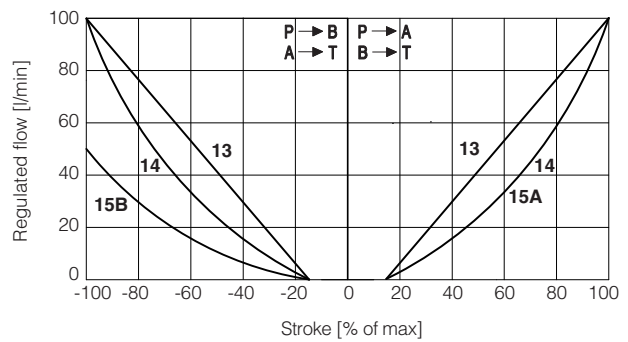

**DKZOR**  
13 = L5 14 = S5  
15A = D5 (P → A, A → T)  
15B = D5 (P → B, B → T)

**Note:** Hydraulic configuration vs. reference signal for configuration 71 and 73 (standard and option /B)

Reference signal  $\left. \begin{matrix} 0 \div +10 \text{ V} \\ 12 \div 20 \text{ mA} \end{matrix} \right\} P \rightarrow A / B \rightarrow T$

Reference signal  $\left. \begin{matrix} 0 \div -10 \text{ V} \\ 12 \div 4 \text{ mA} \end{matrix} \right\} P \rightarrow B / A \rightarrow T$

**10.2 Flow / $\Delta p$  diagrams** - stated at 100% of valve stroke

**DHZO**

- 1 = spool L14
- 2 = spool L1
- 3 = spool S2
- 4 = spool L3, S3, D3
- 5 = spool L5, S5, D5

**DKZOR**

- 6 = spool S3, L3, D3
- 7 = spool S5, L5, D5

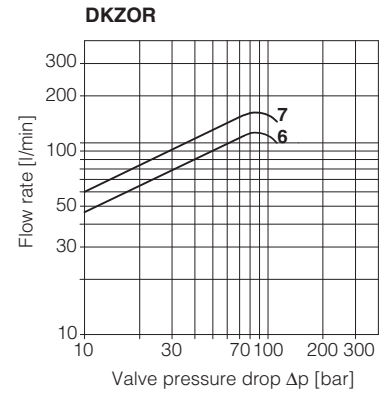
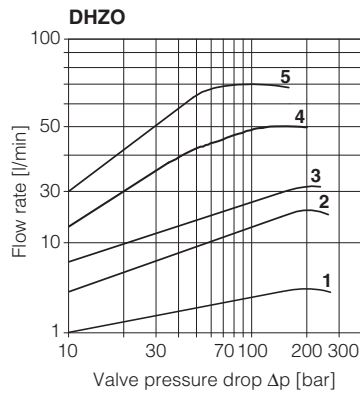

**10.3 Operating limits**

**DHZO**

- 1 = spool L14
- 2 = spool L1
- 3 = spool S2
- 4 = spool L3, S3, D3
- 5 = spool L5, S5, D5

**DKZOR**

- 6 = spool S3, L3, D3
- 7 = spool S5, L5, D5

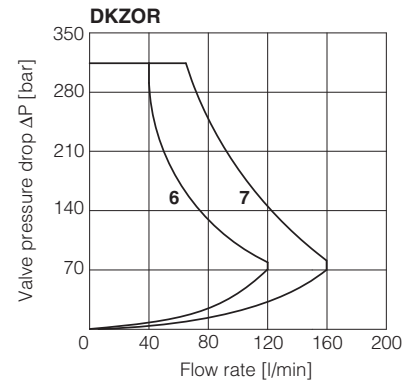
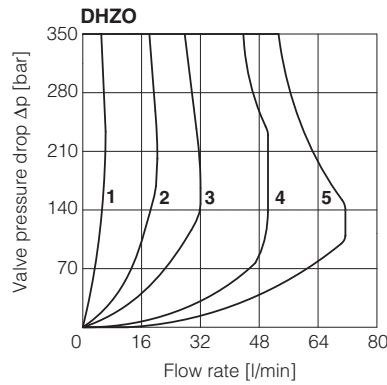

**10.4 Response time**

The response times in below diagrams are measured at different steps of the reference input signal. They have to be considered as average values. For the valves with digital electronics the dynamics performances can be optimized by setting the internal software parameters.

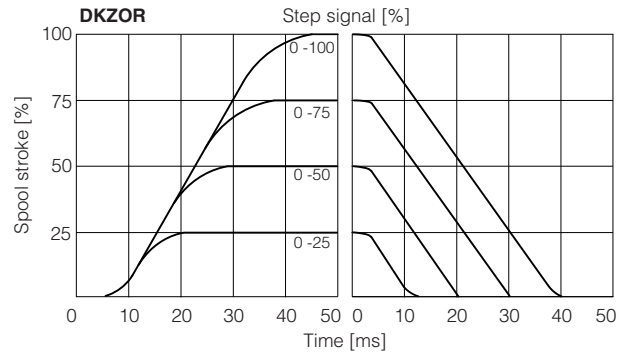
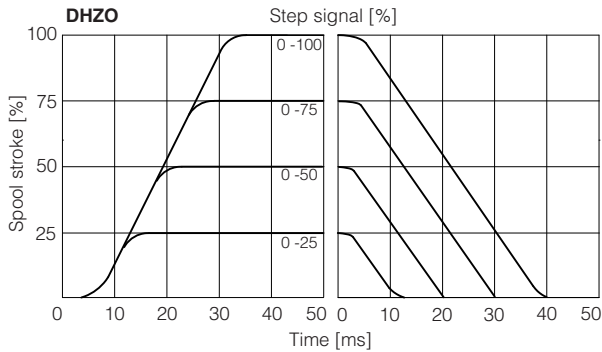

**10.5 Operation as throttle valve**

Single solenoid valves configuration 51 and 53 can be used as simple throttle valves:  
 $P_{max} = 250$  bar (option *Y* advisable)

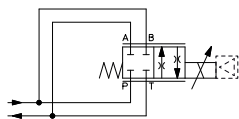

| Max flow<br>$\Delta p = 15$ bar [l/min] | SPOOL TYPE |    |    |          |          |
|---|------------|----|----|----------|----------|
|   | L14        | L1 | S2 | L3<br>S3 | L5<br>S5 |
| <b>DHZO</b>                             | 4          | 16 | 28 | 60       | 100      |
| <b>DKZOR</b>                            | -          | -  | -  | 160      | 200      |

## 11 HYDRAULIC OPTIONS

- B** = DHZO-05 and DKZOR-15 = solenoid and on-board digital driver at side of port A.  
DHZO-07 and DKZOR-17 = on-board digital driver at side of port A.
- Y** = External drain advisable when the valve is used in double flow path, see section 10.5.  
This option is mandatory if the pressure in port T exceeds 210 bar.

**Hand lever option** - only for **DHZO-A** with spool type S3, S5, D3, D5, L3, L5.

It allows to operate the valve in absence of electrical power supply.

For detailed description of DHZO-A with hand lever option see tech. table **E138**.

**MO** = Horizontal hand lever

**BMO** = Horizontal hand lever installed at side of port A

**MV** = Vertical hand lever

**BMV** = Vertical hand lever installed at side of port A

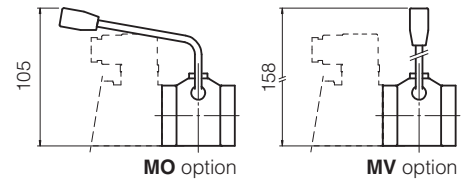

The following supplementary options allow to operate **DHZO-A** and **DKZOR-A** in absence of electrical power supply by means of a micrometric screw replacing the standard solenoid manual override, see tech. table **TK150**

**N** = Manual micrometric adjustment

**NV** = As option /N plus handwheel and graduated scale

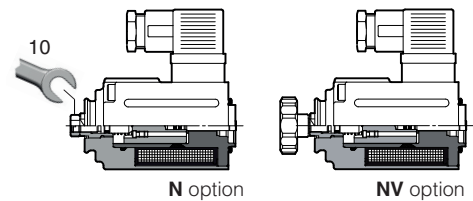

## 12 ELECTRONICS OPTIONS - only for **AEB** and **AES**

**I** = This option provides 4 ÷ 20 mA current reference and monitor signals, instead of the standard ±10 Vdc.

Input signal can be reconfigured via software selecting between voltage and current, within a maximum range of ±10 Vdc or ±20 mA.

It is normally used in case of long distance between the machine control unit and the valve or where the reference signal can be affected by electrical noise; the valve functioning is disabled in case of reference signal cable breakage.

**Q** = This option permits to inhibit the valve function without removing the power supply to the driver. Upon disable command the current to the solenoid is zeroed and the valve's spool moves to rest position.

The option /Q is suggested for all cases where the valve has to be frequently inhibited during the machine cycle – see 15.5 for signal specifications.

**Z** = This option provides, on the 12 pin main connector, the following additional features:

**Fault output signal** - see 15.6

**Enable input signal** - see above option /Q

**Power supply for driver's logics and communication** - see 15.2

**C** = Only in combination with option **/W**

This option is available to connect pressure transducers with 4 ÷ 20 mA current output signal, instead of the standard ±10 Vdc.

Input signal can be reconfigured via software selecting between voltage and current, within a maximum range of ±10 Vdc or ±20 mA.

**W** = Only for valves coupled with pressure compensator, see tech table **D150**.

It provides the hydraulic power limitation function. The driver receives the flow reference signal by the analog input INPUT+ and a pressure transducer, installed in the hydraulic system, has to be connected to the driver's analog input TR. When the actual requested hydraulic power  $p \times Q$  (TR x INPUT+) reaches the max power limit ( $p_1 \times Q_1$ ), internally set by software, the driver automatically reduces the flow regulation of the valve. The higher is the pressure feedback the lower is the valve's regulated flow:

$$\text{Flow regulation} = \text{Min} \left( \frac{\text{PowerLimit [sw setting]}}{\text{Transducer Pressure [TR]}} ; \text{Flow Reference [INPUT+]} \right)$$

### Hydraulic Power Limitation

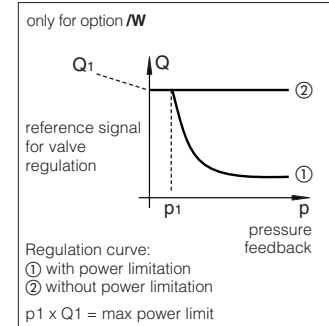

## 13 POSSIBLE COMBINED OPTIONS

**Hydraulic options:** all combination possible

**Electronics options:** /IQ, /IZ, /IW, /CW, /CWI

## 14 COIL VOLTAGE OPTIONS - only for **A**

**6** = Optional coil to be used with Atos drivers with power supply 12 VDC.

**18** = Optional coil to be used with electronic drivers not supplied by Atos, with power supply 24 VDC and with max current limited to 1A.

## 15 POWER SUPPLY AND SIGNALS SPECIFICATIONS - only for AEB and AES

Generic electrical output signals of the valve (e.g. fault or monitor signals) must not be directly used to activate safety functions, like to switch-ON/OFF the machine's safety components, as prescribed by the European standards (Safety requirements of fluid technology systems and components-hydraulics, EN-982).

### 15.1 Power supply (V+ and V0)

The power supply must be appropriately stabilized or rectified and filtered: apply at least a 10000  $\mu\text{F}/40\text{ V}$  capacitance to single phase rectifiers or a 4700  $\mu\text{F}/40\text{ V}$  capacitance to three phase rectifiers. In case of separate power supply see 15.2.



A safety fuse is required in series to each power supply: 2,5 A time lag fuse.

### 15.2 Power supply for driver's logic and communication (VL+ and VL0) - only for /Z and /W options

The power supply for driver's logic and communication must be appropriately stabilized or rectified and filtered: apply at least a 10000  $\mu\text{F}/40\text{ V}$  capacitance to single phase rectifiers or a 4700  $\mu\text{F}/40\text{ V}$  capacitance to three phase rectifiers.

The separate power supply for driver's logic on pin 9 and 10, allow to remove solenoid power supply from pin 1 and 2 maintaining active the diagnostics, USB and fieldbus communications.



A safety fuse is required in series to each driver's logic and communication power supply: 500 mA fast fuse.

### 15.3 Reference input signal (INPUT+)

The driver controls in closed loop the current to the valve proportionally to the external reference input signal.

Reference input signal is factory preset according to selected valve code, defaults are  $\pm 10\text{ V}_{\text{dc}}$  for standard and  $4 \div 20\text{ mA}$  for /I option.

Input signal can be reconfigured via software selecting between voltage and current, within a maximum range of  $\pm 10\text{ V}_{\text{dc}}$  or  $\pm 20\text{ mA}$ .

Drivers with fieldbus interface (BC, BP, EH) can be software set to receive reference signal directly from the machine control unit (fieldbus reference). Analog reference input signal can be used as on-off commands with input range  $0 \div 24\text{V}_{\text{dc}}$ .

### 15.4 Monitor output signals (MONITOR and MONITOR2)

The driver generates an analog output signal (MONITOR) proportional to the actual coil current of the valve; the monitor output signal can be software set to show other signals available in the driver (e.g. analog reference, fieldbus reference).

Monitor output signal is factory preset according to selected valve code, default settings is  $\pm 5\text{ V}_{\text{dc}}$  ( $1\text{V} = 1\text{A}$ ).

Output signal can be reconfigured via software, within a maximum range of  $\pm 5\text{ V}_{\text{dc}}$ .

#### Option /W

The driver generates a second analog output signal (MONITOR2) proportional to the actual system pressure.

The output maximum range is  $\pm 5\text{ V}_{\text{dc}}$ ; default setting is  $0 \div 5\text{ V}_{\text{dc}}$ .

### 15.5 Enable input signal (ENABLE) - not for standard

To enable the driver, supply a  $24\text{ V}_{\text{dc}}$  on pin 3 (pin C): Enable input signal allows to enable/disable the current supply to the solenoid, without removing the electrical power supply to the driver; it is used to active the communication and the other driver functions when the valve must be disabled for safety reasons. This condition **does not comply** with norms IEC 61508 and ISO 13849.

Enable input signal can be used as generic digital input by software selection.

### 15.6 Fault output signal (FAULT) - only for /Z and /W options

Fault output signal indicates fault conditions of the driver (solenoid short circuits/not connected, reference signal broken for  $4 \div 20\text{ mA}$  input, etc.).

Fault presence corresponds to  $0\text{ V}_{\text{dc}}$ , normal working corresponds to  $24\text{ V}_{\text{dc}}$ .

Fault status is not affected by the Enable input signal.

### 15.7 Remote pressure transducer input signal (TR+) - only for /W option

Analog pressure transducers can be directly connected to the driver (see 16.4).

Analog input signal is factory preset according to selected driver code, defaults are  $0 \div 10\text{ V}_{\text{dc}}$  for standard and  $4 \div 20\text{ mA}$  for /C option.

Input signal can be reconfigured via software selecting between voltage and current, within a maximum range of  $\pm 10\text{ V}_{\text{dc}}$  or  $\pm 20\text{ mA}$ .

Note: transducer feedback can be read as a digital information through fieldbus communication - software selectable.

## 16 ELECTRONIC CONNECTIONS

### 16.1 Main connector signals - 7 pin (A1) Standard and /Q option - for AEB and AES

| PIN | Standard                          | /Q     | TECHNICAL SPECIFICATIONS  | NOTES  |
|-----|-----------------------------------|--------|---|--|
| A   | V+                                |        | Power supply 24 Vdc   | Input - power supply                                 |
| B   | V0                                |        | Power supply 0 Vdc  | Gnd - power supply                                   |
| C   | AGND                              |        | Analog ground   | Gnd - analog signal                                  |
|     |                                   | ENABLE | Enable (24 Vdc) or disable (0 Vdc) the driver, referred to V0   | Input - on/off signal                                |
| D   | INPUT+                            |        | Reference input signal: $\pm 10$ Vdc / $\pm 20$ mA maximum range<br>Defaults are $\pm 10$ Vdc for standard and $4 \div 20$ mA for /I option | Input - analog signal<br><b>Software selectable</b>  |
| E   | INPUT-                            |        | Negative reference input signal for INPUT+  | Input - analog signal                                |
| F   | MONITOR referred to:<br>AGND   V0 |        | Monitor output signal: $\pm 5$ Vdc maximum range<br>Default is $\pm 5$ Vdc (1V = 1A)  | Output - analog signal<br><b>Software selectable</b> |
| G   | EARTH                             |        | Internally connected to driver housing  |  |

### 16.2 Main connector signals - 12 pin (A2) /Z and /W options - for AEB and AES

| PIN | /Z      | /W       | TECHNICAL SPECIFICATIONS  | NOTES  |
|-----|---------|----------|---|--|
| 1   | V+      |          | Power supply 24 Vdc   | Input - power supply                                 |
| 2   | V0      |          | Power supply 0 Vdc  | Gnd - power supply                                   |
| 3   | ENABLE  |          | Enable (24 Vdc) or disable (0 Vdc) the driver, referred to V0   | Input - on/off signal                                |
| 4   | INPUT+  |          | Reference input signal: $\pm 10$ Vdc / $\pm 20$ mA maximum range<br>Defaults are $\pm 10$ Vdc for standard and $4 \div 20$ mA for /I option | Input - analog signal<br><b>Software selectable</b>  |
| 5   | INPUT-  |          | Negative reference input signal for INPUT+  | Input - analog signal                                |
| 6   | MONITOR |          | Monitor output signal: $\pm 5$ Vdc maximum range, referred to V0<br>Default is $\pm 5$ Vdc (1V = 1A)  | Output - analog signal<br><b>Software selectable</b> |
| 7   | NC      |          | Do not connect  |  |
| 8   | NC      |          | Do not connect  |  |
|     |         | MONITOR2 | 2nd monitor output signal: $\pm 5$ Vdc maximum range, referred to V0. Default is $0 \div 5$ Vdc   | Output - analog signal                               |
| 9   | VL+     |          | Power supply 24 Vdc for driver's logic and communication  | Input - power supply                                 |
| 10  | V0      |          | Power supply 0 Vdc for driver's logic and communication   | Gnd - power supply                                   |
| 11  | FAULT   |          | Fault (0 Vdc) or normal working (24 Vdc), referred to V0  | Output - on/off signal                               |
| PE  | EARTH   |          | Internally connected to driver housing  |  |

**Note:** do not disconnect V0 before VL+ when the driver is connected to PC USB port

### 16.3 Communication connectors - for AEB (B) and AES (B) - (C)

| (B) USB connector - M12 - 5 pin always present |         |                             |
|--|---------|-----------------------------|
| PIN  | SIGNAL  | TECHNICAL SPECIFICATION (1) |
| 1  | +5V_USB | Power supply                |
| 2  | ID      | Identification              |
| 3  | GND_USB | Signal zero data line       |
| 4  | D-      | Data line -                 |
| 5  | D+      | Data line +                 |

| (C1) BC fieldbus execution, connector - M12 - 5 pin (2) |          |                             |
|---|----------|-----------------------------|
| PIN   | SIGNAL   | TECHNICAL SPECIFICATION (1) |
| 1   | CAN_SHLD | Shield                      |
| 2   | NC       | do not connect              |
| 3   | CAN_GND  | Signal zero data line       |
| 4   | CAN_H    | Bus line (high)             |
| 5   | CAN_L    | Bus line (low)              |

| (C2) BP fieldbus execution, connector - M12 - 5 pin (2) |        |                                       |
|---|--------|---------------------------------------|
| PIN   | SIGNAL | TECHNICAL SPECIFICATION (1)           |
| 1   | +5V    | Termination supply signal             |
| 2   | LINE-A | Bus line (high)                       |
| 3   | DGND   | Data line and termination signal zero |
| 4   | LINE-B | Bus line (low)                        |
| 5   | SHIELD |                                       |

| (C3) (C4) EH fieldbus execution, connector - M12 - 4 pin (2) |        |                             |
|--|--------|-----------------------------|
| PIN  | SIGNAL | TECHNICAL SPECIFICATION (1) |
| 1  | TX+    | Transmitter                 |
| 2  | RX+    | Receiver                    |
| 3  | TX-    | Transmitter                 |
| 4  | RX-    | Receiver                    |
| Housing  | SHIELD |                             |

(1) Shield connection on connector's housing is recommended

(2) Only for AES execution



**16.4 Remote pressure transducer connector - M12 - 5 pin - only for /W option - for AEB and AES (D)**

| PIN | SIGNAL  | TECHNICAL SPECIFICATION   | Voltage | Current |
|-----|---------|---|---------|---------|
| 1   | VF +24V | Power supply +24Vdc   | Connect | Connect |
| 2   | TR      | Signal transducer maximum range $\pm 10$ Vdc / $\pm 20$ mA, software selectable<br>Defaults are 0 $\div$ 10 Vdc for standard and 4 $\div$ 20 mA for /C option | Connect | Connect |
| 3   | AGND    | Common GND for transducer power and signals   | Connect | /       |
| 4   | NC      | Not Connect   | /       | /       |
| 5   | NC      | Not Connect   | /       | /       |

**Remote pressure transducer connection - example**

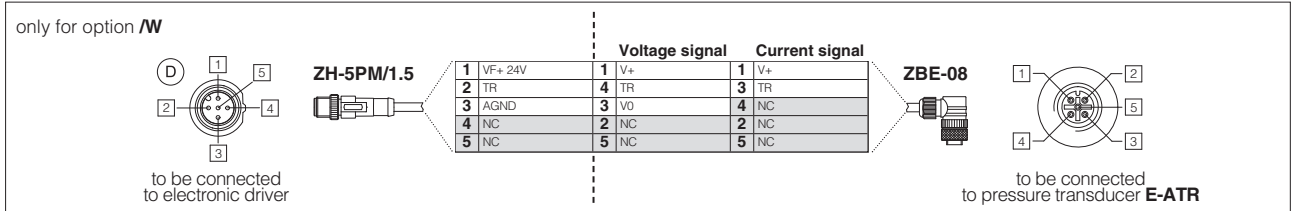

**Note:** connectors front view

**16.5 Solenoid connection - only for A**

| PIN | SIGNAL | TECHNICAL SPECIFICATION | Connector code 666 |
|-----|--------|-------------------------|--------------------|
| 1   | COIL   | Power supply            |                    |
| 2   | COIL   | Power supply            |                    |
| 3   | GND    | Ground                  |                    |

**16.6 AEB connections layout**

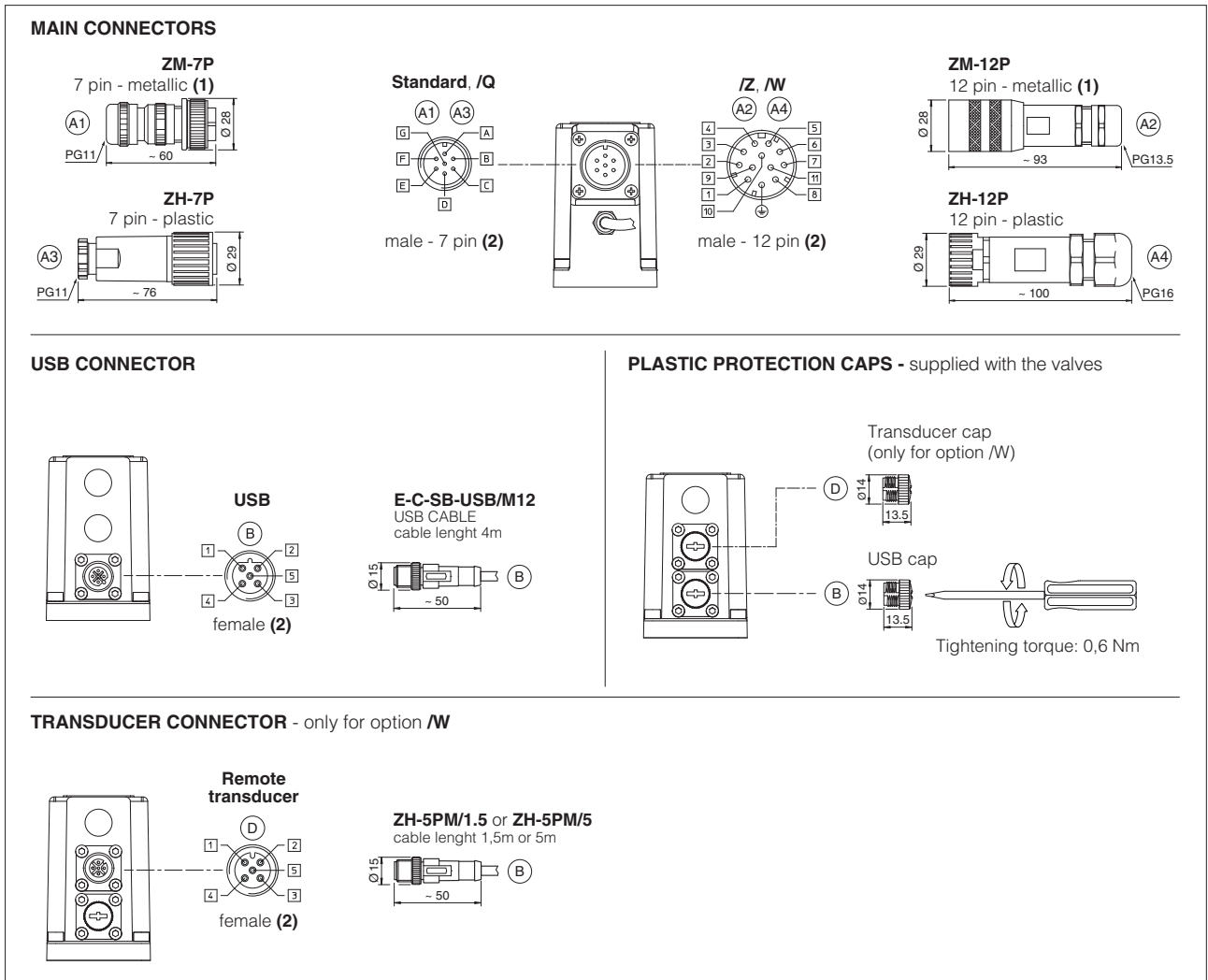

(1) Use of metallic connectors is strongly recommended in order to fulfill EMC requirements

(2) Pin layout always referred to driver's view

## 16.7 AES connections layout

### MAIN CONNECTORS

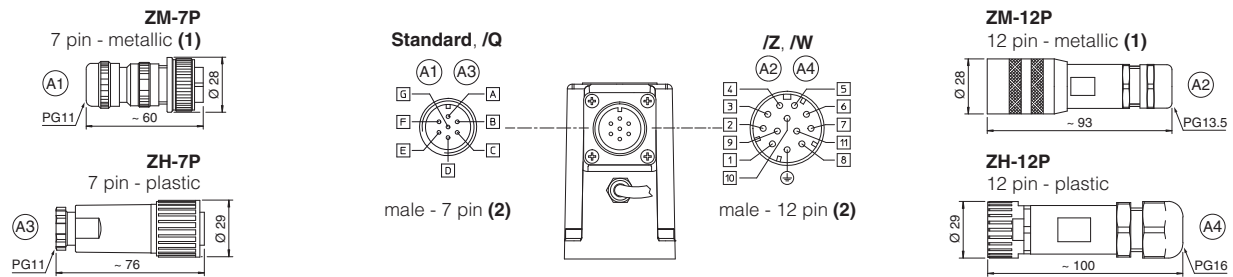

### FIELDBUS CONNECTORS

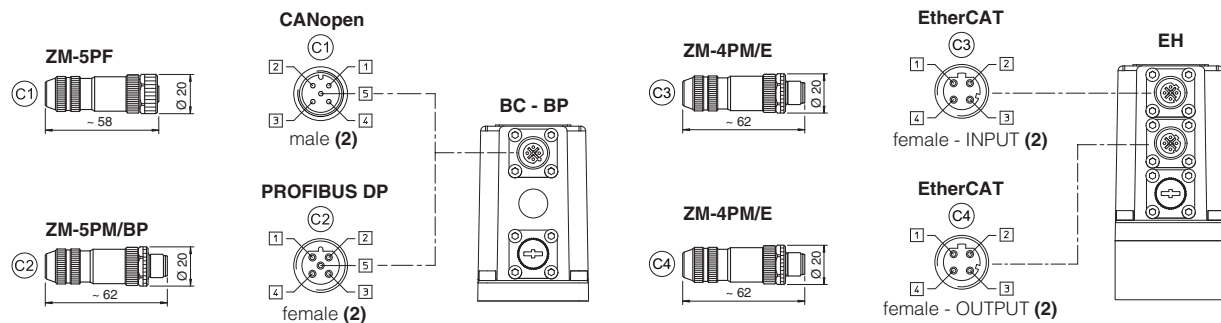

### USB CONNECTOR

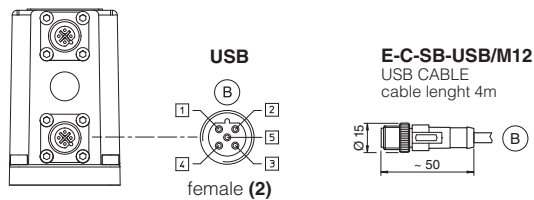

### PLASTIC PROTECTION CAPS - supplied with the valves

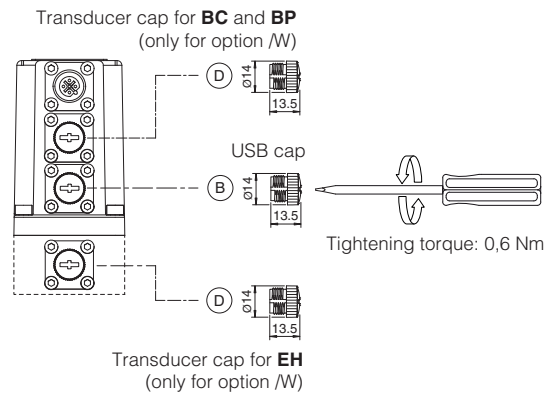

### TRANSDUCER CONNECTOR - only for option /W

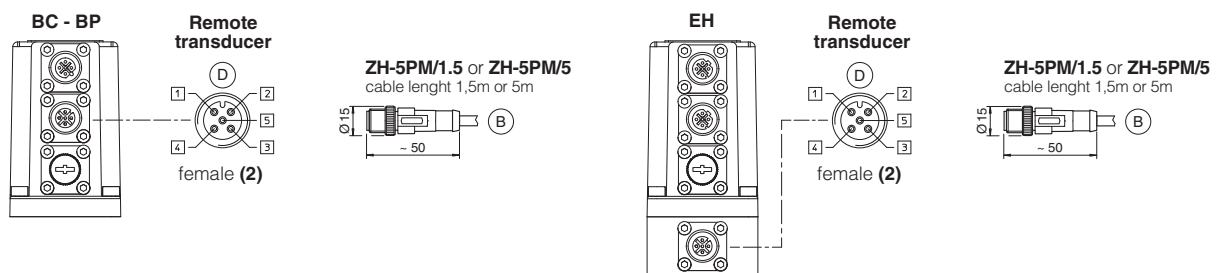

(1) Use of metallic connectors is strongly recommended in order to fulfill EMC requirements

(2) Pin layout always referred to driver's view

**17 CONNECTORS CHARACTERISTICS** - to be ordered separately

**17.1 Main connectors - 7 pin - for AEB and AES**

| CONNECTOR TYPE        | POWER SUPPLY   | POWER SUPPLY   |
|-----------------------|--|--|
| <b>CODE</b>           | <b>(A1) ZM-7P</b>  | <b>(A3) ZH-7P</b>  |
| Type                  | 7pin female straight circular  | 7pin female straight circular  |
| Standard              | According to MIL-C-5015  | According to MIL-C-5015  |
| Material              | Metallic   | Plastic reinforced with fiber glass  |
| Cable gland           | PG11   | PG11   |
| Recommended cable     | LiYCY 7 x 0,75 mm <sup>2</sup> max 20 m (logic and power supply)<br>or LiYCY 7 x 1 mm <sup>2</sup> max 40 m (logic and power supply) | LiYCY 7 x 0,75 mm <sup>2</sup> max 20 m (logic and power supply)<br>or LiYCY 7 x 1 mm <sup>2</sup> max 40 m (logic and power supply) |
| Conductor size        | up to 1 mm <sup>2</sup> - available for 7 wires  | up to 1 mm <sup>2</sup> - available for 7 wires  |
| Connection type       | to solder  | to solder  |
| Protection (EN 60529) | IP 67  | IP 67  |

**17.2 Main connectors - 12 pin - for AEB and AES**

| CONNECTOR TYPE        | POWER SUPPLY  | POWER SUPPLY  |
|-----------------------|---|---|
| <b>CODE</b>           | <b>(A2) ZM-12P</b>  | <b>(A4) ZH-12P</b>  |
| Type                  | 12pin female straight circular                                      | 12pin female straight circular  |
| Standard              | DIN 43651   | DIN 43651   |
| Material              | Metallic  | Plastic reinforced with fiber glass   |
| Cable gland           | PG13,5  | PG16  |
| Recommended cable     | LiYCY 12 x 0,75 mm <sup>2</sup> max 20 m (logic and power supply)   | LiYCY 10 x 0,14mm <sup>2</sup> max 40 m (logic)<br>LiYY 3 x 1mm <sup>2</sup> max 40 m (power supply)                                      |
| Conductor size        | 0,5 mm <sup>2</sup> to 1,5 mm <sup>2</sup> - available for 12 wires | 0,14 mm <sup>2</sup> to 0,5 mm <sup>2</sup> - available for 9 wires<br>0,5 mm <sup>2</sup> to 1,5 mm <sup>2</sup> - available for 3 wires |
| Connection type       | to crimp  | to crimp  |
| Protection (EN 60529) | IP 67   | IP 67   |

**17.3 Fieldbus communication connectors - only for AES**

| CONNECTOR TYPE        | BC CANopen (1)                       |                              | BP PROFIBUS DP (1)                   |                              | EH EtherCAT (2)                      |
|-----------------------|--------------------------------------|------------------------------|--------------------------------------|------------------------------|--------------------------------------|
| <b>CODE</b>           | <b>(C1) ZM-5PF</b>                   | <b>(C2) ZM-5PM</b>           | <b>(C1) ZM-5PF/BP</b>                | <b>(C2) ZM-5PM/BP</b>        | <b>(C1) (C2) ZM-4PM/E</b>            |
| Type                  | 5 pin female straight circular       | 5 pin male straight circular | 5 pin female straight circular       | 5 pin male straight circular | 4 pin male straight circular         |
| Standard              | M12 coding A – IEC 61076-2-101       |                              | M12 coding B – IEC 61076-2-101       |                              | M12 coding D – IEC 61076-2-101       |
| Material              | Metallic                             |                              | Metallic                             |                              | Metallic                             |
| Cable gland           | Pressure nut - cable diameter 6÷8 mm |                              | Pressure nut - cable diameter 6÷8 mm |                              | Pressure nut - cable diameter 4÷8 mm |
| Cable                 | CANbus Standard (DR 303-1)           |                              | PROFIBUS DP Standard                 |                              | Ethernet standard CAT-5              |
| Connection type       | screw terminal                       |                              | screw terminal                       |                              | terminal block                       |
| Protection (EN 60529) | IP67                                 |                              | IP 67                                |                              | IP 67                                |



**(1)** E-TRM-\*\* terminators can be ordered separately - see tech table **GS500**

**(2)** Internally terminated

**17.4 Pressure transducer connectors - only for /W option**

| CONNECTOR TYPE        | TRANSDUCER                     |                      |
|-----------------------|--------------------------------|----------------------|
| <b>CODE</b>           | <b>(D1) ZH-5PM/1.5</b>         | <b>(D1) ZH-5PM/5</b> |
| Type                  | 5 pin male straight circular   |                      |
| Standard              | M12 coding A – IEC 61076-2-101 |                      |
| Material              | Plastic                        |                      |
| Cable gland           | Connector moulded on cables    |                      |
|                       | 1,5 m length                   | 5 m length           |
| Cable                 | 5 x 0,25 mm <sup>2</sup>       |                      |
| Connection type       | molded cable                   |                      |
| Protection (EN 60529) | IP 67                          |                      |

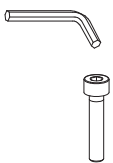
**18 FASTENING BOLTS AND SEALS**

|   | DHZO   | DKZOR   |
|---|--|---|
|  | <p><b>Fastening bolts:</b></p> <p>4 socket head screws M5x50 class 12.9</p> <p>Tightening torque = 8 Nm</p>  | <p><b>Fastening bolts:</b></p> <p>4 socket head screws M6x40 class 12.9</p> <p>Tightening torque = 15 Nm</p>  |
|  | <p><b>Seals:</b></p> <p>4 OR 108<br/>Diameter of ports A, B, P, T: Ø 7,5 mm (max)</p> <p>1 OR 2025<br/>Diameter of port Y: Ø 3,2 mm (only for /Y option)</p> | <p><b>Seals:</b></p> <p>5 OR 2050<br/>Diameter of ports A, B, P, T: Ø 11,2 mm (max)</p> <p>1 OR 108<br/>Diameter of port Y: Ø 5 mm (only for /Y option)</p> |

19 INSTALLATION DIMENSIONS FOR DHZO [mm]

ISO 4401: 2005

Mounting surface: 4401-03-02-0-05 (see table P005)

(for /Y version, surface 4401-03-03-0-05 without X port)

|           | Mass [kg] |          |        |
|-----------|-----------|----------|--------|
|           | A         | AEB, AES | AES-EH |
| DHZO-*-05 | 1,9       | 2,3      | 2,4    |
| DHZO-*-07 | 2,6       | 3,1      | 3,2    |

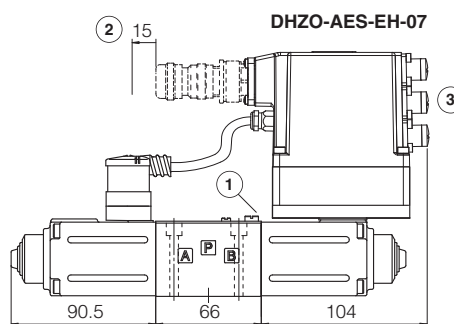
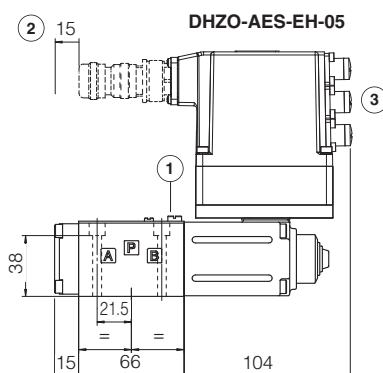
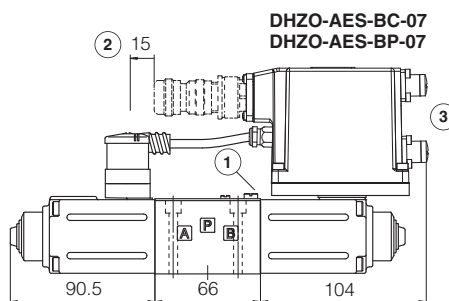
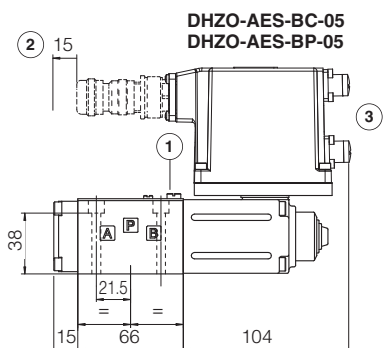
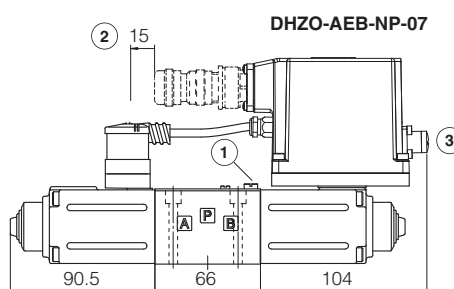
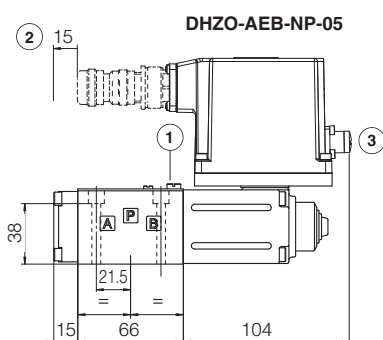
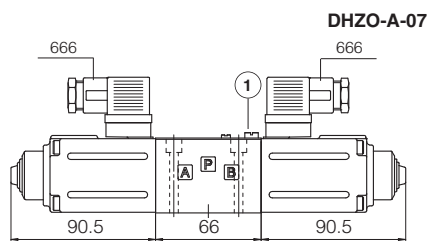
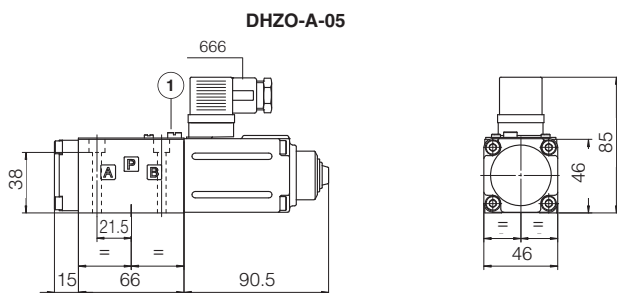

- ① = Air bleeding 3
- ② = Space to remove the connectors
- ③ = The dimensions of all connectors must be considered, see section 16.6 and 16.7

**Note:** for option /B the solenoid and the on-board digital driver are at side of port A

20 INSTALLATION DIMENSIONS FOR DKZOR [mm]

ISO 4401: 2005

Mounting surface: 4401-05-04-0-05 (see table P005)

(for /Y version, surface 4401-05-05-0-05 without X port)

|            | Mass [kg] |          |        |
|------------|-----------|----------|--------|
|            | A         | AEB, AES | AES-EH |
| DKZOR-*-15 | 3,8       | 4,3      | 4,4    |
| DKZOR-*-17 | 4,5       | 5,0      | 5,1    |

DKZOR-A-15

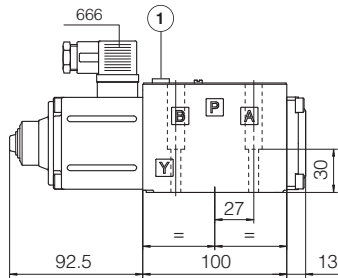

DKZOR-A-17

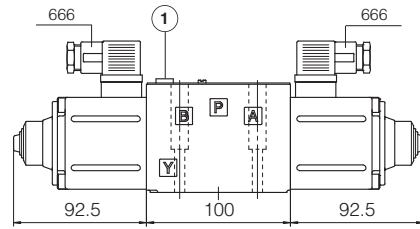

DKZOR-AEB-NP-15

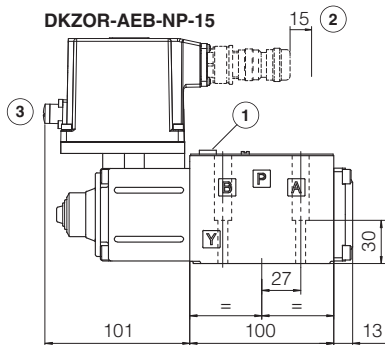

DKZOR-AEB-NP-17

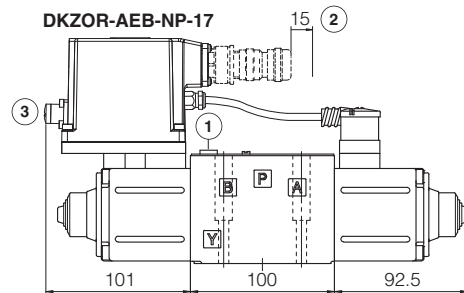

DKZOR-AES-BC-15  
DKZOR-AES-BP-15

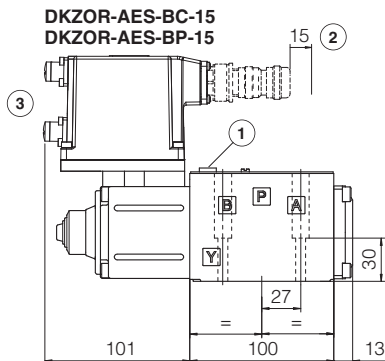

DKZOR-AES-BC-17  
DKZOR-AES-BP-17

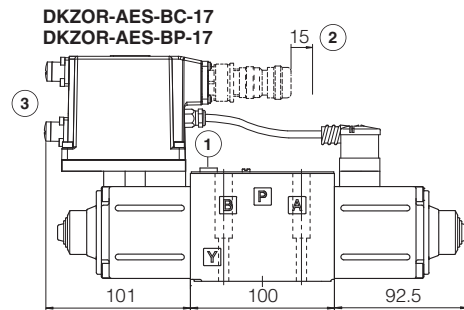

DKZOR-AES-EH-15

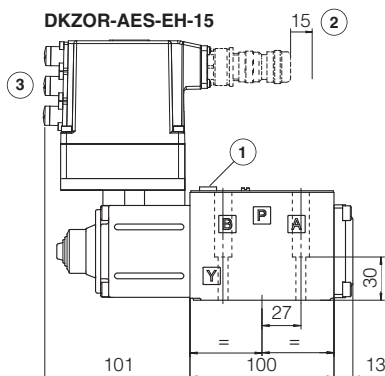

DKZOR-AES-EH-17

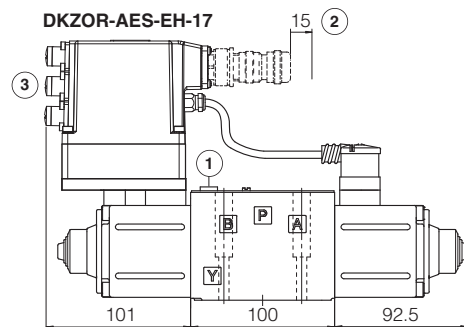

① = Air bleeding 

② = Space to remove the connectors

③ = The dimensions of all connectors must be considered, see section 16.6 and 16.7

Note: for option /B the solenoid and the on-board digital driver are at side of port A

**21** RELATED DOCUMENTATION

|              |   |              |   |
|--------------|---|--------------|---|
| <b>FS001</b> | Basics for digital electrohydraulics                          | <b>GS510</b> | Fieldbus                                      |
| <b>FS900</b> | Operating and maintenance information for proportional valves | <b>K800</b>  | Electric and electronic connectors            |
| <b>G010</b>  | E-MI-AC analog driver   | <b>P005</b>  | Mounting surfaces for electrohydraulic valves |
| <b>G020</b>  | E-MI-AS-IR digital driver                                     | <b>QB100</b> | Quickstart for AEB valves commissioning       |
| <b>G030</b>  | E-BM-AS digital driver  | <b>QF100</b> | Quickstart for AES valves commissioning       |
| <b>GS050</b> | E-BM-AES digital driver                                       |              |   |
| <b>GS500</b> | Programming tools   |              |   |