

2 GENERAL NOTES

Atos digital proportionals valves are CE marked according to the applicable directives (e.g. Immunity and Emission EMC Directive). Installation, wirings and start-up procedures must be performed according to the general prescriptions shown in tech table **FX900** and in the user manuals included in the E-SW-SETUP programming software.

3 VALVE SETTINGS AND PROGRAMMING TOOLS - see tech. table **GS500**



WARNING: the below operation must be performed in a safety area!

3.1 Atos CONNECT mobile App

Free downloadable App for smartphones and tablets which allows quick access to valve main functional parameters and basic diagnostic information via Bluetooth, thus avoiding physical cable connection and significantly reducing commissioning time. Atos CONNECT supports Atos digital valve drivers equipped with E-A-BTH adapter or with built-in Bluetooth. It does not support valves with p/Q control or axis controls.



3.2 E-SW-SETUP PC software

Free downloadable software for PC allows to set all valve functional parameters and to access complete diagnostic information of digital valve drivers via Bluetooth/USB service port. Atos E-SW-SETUP PC software supports all Atos digital valve drivers and it is available at www.atos.com in MyAtos area.



WARNING: drivers USB port is not isolated! For E-C-SB-USB/M12 cable, the use of E-A-SB-USB/OPT isolator adapter is highly recommended for PC protection



WARNING: for the list of countries where the Bluetooth adapter has been approved, see tech. table **GS500**

Bluetooth or USB connection

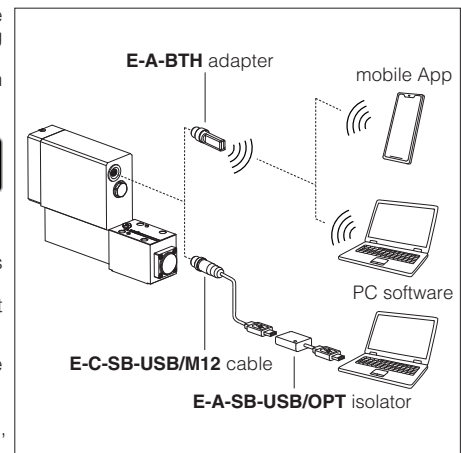

4 FIELDBUS - see tech. table **GS510**

Fieldbus allows valve direct communication with machine control unit for digital reference, valve diagnostics and settings. These executions allow to operate the valves through fieldbus or analog signals available on the terminal board.

5 ALTERNATED p/Q CONTROLS - see tech. table **FX500**

S* options add the closed loop control of pressure (**SP**) or force (**SF** and **SL**) to the basic functions of proportional directional valves flow regulation. A dedicated algorithm alternates pressure (force) depending on the actual hydraulic system conditions.

An additional connector is available for transducers to be interfaced to the valve's driver (1 pressure transducer for SP, 2 pressure transducers for SF or 1 load cell for SL). The alternated pressure control (SP) is possible only for specific installation conditions.

6 AXIS CONTROLLER - see tech. table **FX620**

Digital servoproportional with integral electronics **TEZ** include valve's driver plus axis controller, performing position closed loop of any hydraulic actuator equipped with analog, encoder or SSI position transducer. Alternated pressure or force closed loop control can be set by software additionally to the position control.

Atos also supplies complete servoactuators integrating servocylinder, digital servoproportional valve and axis controller, fully assembled and tested. For more information consult Atos Technical Office.

7 GENERAL CHARACTERISTICS

Assembly position	Any position
Subplate surface finishing to ISO 4401	Acceptable roughness index, Ra ≤0,8 recommended Ra 0,4 - flatness ratio 0,01/100
MTTFd valves according to EN ISO 13849	150 years, for further details see technical table P007
Ambient temperature range	Standard = -20°C ÷ +60°C /PE option = -20°C ÷ +60°C /BT option = -40°C ÷ +60°C
Storage temperature range	Standard = -20°C ÷ +70°C /PE option = -20°C ÷ +70°C /BT option = -40°C ÷ +70°C
Surface protection	Zinc coating with black passivation
Corrosion resistance	Salt spray test (ISO 9227) > 200 h
Vibration resistance	See technical table GX004
Compliance	Explosion proof protection, see section 11 -Flame proof enclosure "Ex d" -Dust ignition protection by enclosure "Ex t" RoHs Directive 2011/65/EU as last update by 2015/863/EU REACH Regulation (EC) n°1907/2006

8 HYDRAULIC CHARACTERISTICS - based on mineral oil ISO VG 46 at 50 °C

Valve model	DHZA			DKZA		
Pressure limits [bar]	ports P, A, B = 350; T = 210 (250 with external drain /Y); Y = 10			ports P, A, B = 315; T = 210 (250 with external drain /Y); Y = 10		
Spool type and size	L3	L5	D5	L3	L5	D5
Nominal flow						
[l/min] at $\Delta p = 10$ bar	18	28	28	45	75	75
Δp P-T at $\Delta p = 30$ bar	30	50	50	80	130	130
max permissible flow	40	60	60	90	150	150
Δp max P-T [bar]	70	50	50	40	40	40
Response time [ms] (1)	≤ 18			≤ 25		
Leakage [cm ³]	<500 (at P = 100 bar); <1500 (at P = 350 bar)			<800 (at P = 100 bar); <2500 (at P = 315 bar)		
Hysteresis	≤ 0,2 [% of max regulation]					
Repeatability	± 0,1 [% of max regulation]					
Thermal drift	zero point displacement < 1% at $\Delta T = 40^\circ C$					

(1) 0-100% step signal

9 ELECTRICAL CHARACTERISTICS

Power supplies	Nominal : +24 VDC Rectified and filtered : $V_{RMS} = 20 \div 32 V_{MAX}$ (ripple max 10 % VPP)			
Max power consumption	35 W			
Analog input signals	Voltage: range ± 10 VDC (24 VMAX tolerant) Current: range ± 20 mA		Input impedance: $R_i > 50$ k Ω Input impedance: $R_i = 500 \Omega$	
Insulation class	H (180°) Due to the occurring surface temperatures of the solenoid coils, the European standards ISO 13732-1 and EN982 must be taken into account			
Monitor outputs	Output range: voltage ± 10 VDC @ max 5 mA current ± 20 mA @ max 500 Ω load resistance			
Enable input	Range: 0 \div 5 Vdc (OFF state), 9 \div 24 Vdc (ON state), 5 \div 9 Vdc (not accepted); Input impedance: $R_i > 10$ k Ω			
Fault output	Output range: 0 \div 24 Vdc (ON state > [power supply - 2 V]; OFF state < 1 V) @ max 50 mA; external negative voltage not allowed (e.g. due to inductive loads)			
Pressure transducer power supply	+24VDC @ max 100 mA (E-ATRA-7 see tech table GX800)			
Alarms	Solenoid not connected/short circuit, cable break with current reference signal, over/under temperature, valve spool transducer malfunctions, alarm history storage function			
Protection degree to DIN EN60529	IP66/67 with relevant cable gland			
Duty factor	Continuous rating (ED=100%)			
Tropicalization	Tropical coating on electronics PCB			
Additional characteristics	Short circuit protection of solenoid current supply; spool position control (SN) or pressure/force control (SP, SF, SL) by P.I.D. with rapid solenoid switching; protection against reverse polarity of power supply			
Electromagnetic compatibility (EMC)	According to Directive 2014/30/UE (Immunity: EN 61000-6-2; Emission: EN 61000-6-3)			
Communication interface	USB Atos ASCII coding	CANopen EN50325-4 + DS408	PROFIBUS DP EN50170-2/IEC61158	EtherCAT, POWERLINK, EtherNet/IP, PROFINET IO RT / IRT EC 61158
Communication physical layer	not insulated USB 2.0 + USB OTG	optical insulated CAN ISO11898	optical insulated RS485	Fast Ethernet, insulated 100 Base TX

Note: a maximum time of 800 ms (depending on communication type) has to be considered between the driver energizing with the 24 VDC power supply and when the valve is ready to operate. During this time the current to the valve coils is switched to zero

10 SEALS AND HYDRAULIC FLUIDS - for other fluids not included in below table, consult our technical office

Seals, recommended fluid temperature	NBR seals (standard) = -20°C \div +60°C, with HFC hydraulic fluids = -20°C \div +50°C FKM seals (/PE option) = -20°C \div +80°C NBR low temp. seals (/BT option) = -40°C \div +60°C, with HFC hydraulic fluids = -20°C \div +50°C		
Recommended viscosity	20 \div 100 mm ² /s - max allowed range 15 \div 380 mm ² /s		
Max fluid contamination level	normal operation	ISO4406 class 18/16/13 NAS1638 class 7	see also filter section at
	longer life	ISO4406 class 16/14/11 NAS1638 class 5	www.atos.com or KTF catalog
Hydraulic fluid	Suitable seals type	Classification	Ref. Standard
Mineral oils	NBR, FKM, NBR low temp.	HL, HLP, HLPD, HVLP, HVLPD	DIN 51524
Flame resistant without water	FKM	HFDU, HFDR	ISO 12922
Flame resistant with water (1)	NBR, NBR low temp.	HFC	



The ignition temperature of the hydraulic fluid must be 50°C higher than the max solenoid surface temperature

(1) Performance limitations in case of flame resistant fluids with water:

- max operating pressure = 210 bar
- max fluid temperature = 50°C

11 CERTIFICATION DATA

Valve type	DHZA, DKZA				
Certifications	Multicertification Group II ATEX IECEx EAC CCC				
Solenoid certified code	OZA-TES			OZA-A	
Type examination certificate (1)	<ul style="list-style-type: none"> • ATEX: TUV IT 18 ATEX 068 X • IECEx: IECEx TPS 19.0004X • EAC: RU C - IT.AX38.B.00425/21 • CCC: 2021322307004057 			<ul style="list-style-type: none"> • ATEX: CESI 02 ATEX 014 • IECEx: IECEx CES 10.0010x • EAC:RU C - IT.AX38.B.00425/21 • CCC: 2020322307003240 	
Method of protection	<ul style="list-style-type: none"> • ATEX Ex II 2G Ex db IIC T6/T5/T4 Gb; Ex II 2D Ex tb IIIC T85°C/T100°C/T135°C Db • IECEx Ex db IIC T6/T5/T4 Gb Ex tb IIIC T85°C/T100°C/T135°C Db • EAC 1Ex d IIC T6/T5/T4 Gb X; Ex tb IIIC T85°C/T100°C/T135°C Db X • CCC Ex d IIC T6/T5/T4 Gb; Ex tD A21 IP66/IP67 T85°C/T100°C/T135°C 			<ul style="list-style-type: none"> • ATEX, EAC Ex II 2G Ex db IIC T4/T3 Gb Ex II 2D Ex tb IIIC T135°C/T200°C Db • IECEx Ex db IIC T4/T3 Gb Ex tb IIIC T135°C/T200°C Db • EAC 1Ex d IIC T4/T3 Gb X; Ex tb IIIC T135°C/T200°C Db X • CCC Ex d IIC T4/T3 Gb Ex tD A21 IP66/IP67 T135°C/T200°C 	
Temperature class	T6	T5	T4	T4	T3
Surface temperature	≤ 85 °C	≤ 100 °C	≤ 135 °C	≤ 135 °C	≤ 200 °C
Ambient temperature (2)	-40 ÷ +40 °C	-40 ÷ +55 °C	-40 ÷ +70 °C	-40 ÷ +40 °C	-40 ÷ +70 °C
Applicable Standards	EN 60079-0 IEC 60079-0		EN 60079-1 IEC 60079-31		EN 60079-31 IEC 60079-1
Cable entrance: threaded connection	M = M20x1,5				

(1) The type examination certificates can be downloaded from www.atos.com

(2) The driver and solenoids are certified for minimum ambient temperature -40°C.

In case the complete valve must withstand with minimum ambient temperature -40°C, select **/BT** in the model code.

⚠ WARNING: service work performed on the valve by the end users or not qualified personnel invalidates the certification.

12 CABLE SPECIFICATION AND TEMPERATURE - Power supply and grounding cables have to comply with following characteristics:

Power supply and signals: section of wire = 1,0 mm ²	Grounding: section of external ground wire = 4 mm ²
--	---

12.1 Cable temperature

The cable must be suitable for the working temperature as specified in the "safety instructions" delivered with the first supply of the products.

Max ambient temperature [°C]	Temperature class	Max surface temperature [°C]	Min. cable temperature [°C]
40 °C	T6	85 °C	80 °C
55 °C	T5	100 °C	90 °C
70 °C	T4	135 °C	110 °C

13 CABLE GLANDS

Cable glands with threaded connections M20x1,5 for standard or armoured cables have to be ordered separately, see tech table **KX800**

Note: a Loctite sealant type 545, should be used on the cable gland entry threads

14 HYDRAULIC OPTIONS

- B** = Solenoid, integral electronics and position transducer at side of port A of the main stage. For hydraulic configuration vs reference signal, see 17.1
- Y** = Option /Y is mandatory if the pressure in port T exceeds 210 bar

15 ELECTRONIC OPTIONS

- I** = It provides 4 ÷ 20 mA current reference signal, instead of the standard ±10 VDC. Input signal can be reconfigured via software selecting between voltage and current, within a maximum range of ±10 Vdc or ±20 mA. It is normally used in case of long distance between the machine control unit and the valve or where the reference signal can be affected by electrical noise; the valve functioning is disabled in case of reference signal cable breakage.
- C** = Only for **SP, SF, SL**
Option /C is available to connect pressure (force) transducers with 4 ÷ 20 mA current output signal, instead of the standard ±10 Vdc. Input signal can be reconfigured via software selecting between voltage and current, within a maximum range of ±10 Vdc or ±20 mA.

16 POSSIBLE COMBINED OPTIONS

For **SN**: /BI, /BY, /IY

For **SP, SF, SL**: /BI, /BY, /IY, /CI, /BCI, CIY, BCIY

17 DIAGRAMS - based on mineral oil ISO VG 46 at 50 °C

17.1 Regulation diagrams (values measure at Δp 30 bar P-T)

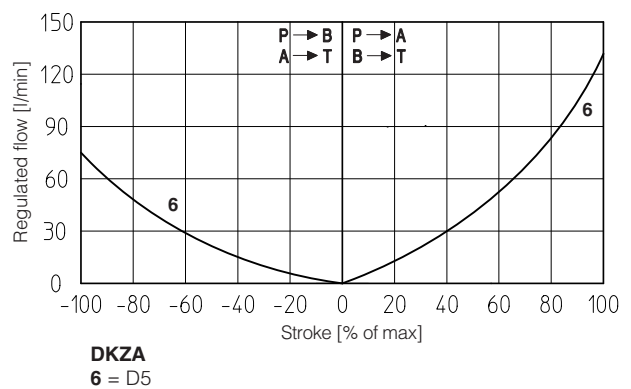
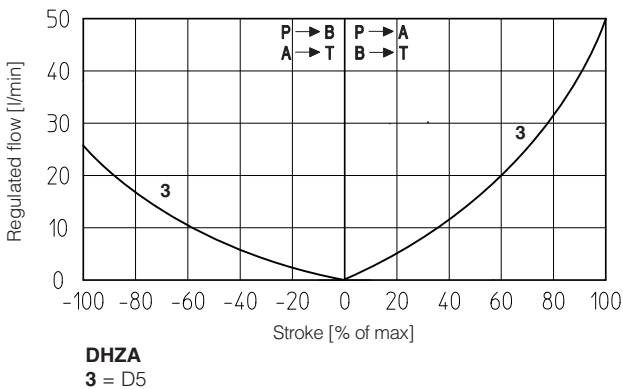
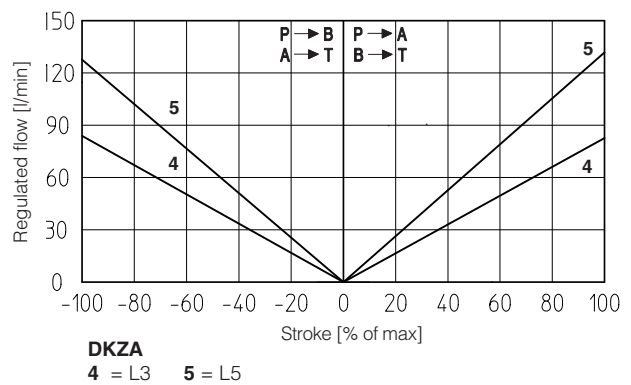
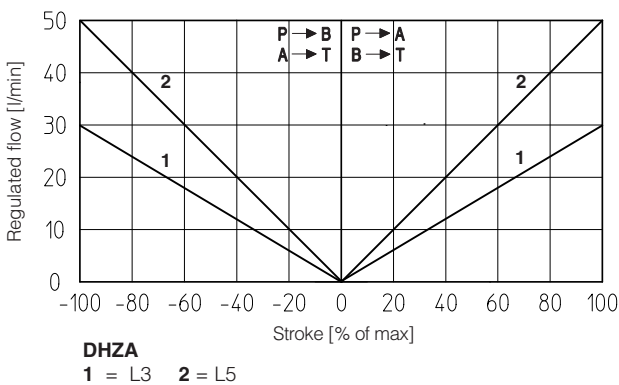

Note:

Hydraulic configuration vs. reference signal for configurations 71 and 73 (standard and option /B)

Reference signal $\left. \begin{matrix} 0 \div +10 \text{ V} \\ 12 \div 20 \text{ mA} \end{matrix} \right\} P \rightarrow A / B \rightarrow T$ Reference signal $\left. \begin{matrix} 0 \div -10 \text{ V} \\ 12 \div 4 \text{ mA} \end{matrix} \right\} P \rightarrow B / A \rightarrow T$

17.2 Spool safety rest position

In absence of electric power supply (+24 VDC), the valve spool is moved by the springs force to the **safety rest position** characterized by a small offset of about 1% to 6% of the total stroke in P-B / A-T configuration. This is specifically designed to avoid that in case of accidental interruption of the electrical power supply to the valve, the actuator moves towards an undefined direction (due to the tolerances of the zero overlap spool), with potential risk of damages or personnel injury. Thanks to the **safety rest position** the actuator movement is suddenly stopped and it is recovered at very low speed towards the direction corresponding to the P-B/ A-T connection.

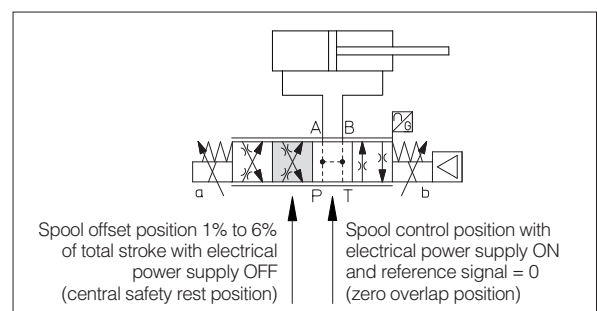

18 POWER SUPPLY AND SIGNALS SPECIFICATIONS

Generic electrical output signals of the valve (e.g. fault or monitor signals) must not be directly used to activate safety functions, like to switch-ON/OFF the machine's safety components, as prescribed by the European standards (Safety requirements of fluid technology systems and components-hydraulics, ISO 4413).

18.1 Power supply (V+ and V0)

The power supply must be appropriately stabilized or rectified and filtered: apply at least a 10000 $\mu\text{F}/40\text{ V}$ capacitance to single phase rectifiers or a 4700 $\mu\text{F}/40\text{ V}$ capacitance to three phase rectifiers.

 A safety fuse is required in series to each power supply: 2,5 A time lag fuse.

18.2 Power supply for driver's logic and communication (VL+ and VL0)

The power supply for driver's logic and communication must be appropriately stabilized or rectified and filtered: apply at least a 10000 $\mu\text{F}/40\text{ V}$ capacitance to single phase rectifiers or a 4700 $\mu\text{F}/40\text{ V}$ capacitance to three phase rectifiers.

The separate power supply for driver's logic on pin 3 and 4, allow to remove solenoid power supply from pin 1 and 2 maintaining active the diagnostics, USB and fieldbus communications.

 A safety fuse is required in series to each driver's logic and communication power supply: 500 mA fast fuse.

18.3 Flow reference input signal (Q_INPUT+)

The driver controls in closed loop the valve spool position proportionally to the external reference input signal.

Reference input signal is factory preset according to selected valve code, defaults are $\pm 10\text{ Vdc}$ for standard and $4 \div 20\text{ mA}$ for /I option.

Input signal can be reconfigured via software selecting between voltage and current, within a maximum range of $\pm 10\text{ VDC}$ or $\pm 20\text{ mA}$.

Drivers with fieldbus interface can be software set to receive reference signal directly from the machine control unit (fieldbus reference). Analog reference input signal can be used as on-off commands with input range $0 \div 24\text{VDC}$.

18.4 Pressure or force reference input signal (F_INPUT+) - only SP, SF, SL

Functionality of F_INPUT+ signal (pin 12), is used as reference for the driver pressure/force closed loop (see tech. table FX500).

Reference input signal is factory preset according to selected valve code, defaults are $\pm 10\text{ Vdc}$ for standard and $4 \div 20\text{ mA}$ for /I option.

Input signal can be reconfigured via software selecting between voltage and current, within a maximum range of $\pm 10\text{ VDC}$ or $\pm 20\text{ mA}$.

Drivers with fieldbus interface can be software set to receive reference signal directly by the machine control unit (fieldbus reference).

Analog reference input signal can be used as on-off commands with input range $0 \div 24\text{VDC}$.

18.5 Flow monitor output signal (Q_MONITOR)

The driver generates an analog output signal proportional to the actual spool position of the valve; the monitor output signal can be software set to show other signals available in the driver (e.g. analog reference, fieldbus reference, pilot spool position).

Monitor output signal is factory preset according to selected valve code, defaults are $\pm 10\text{ VDC}$ for standard and $4 \div 20\text{ mA}$ for /I option.

Output signal can be reconfigured via software selecting between voltage and current, within a maximum range of $\pm 10\text{ VDC}$ or $\pm 20\text{ mA}$.

18.6 Pressure or force monitor output signal (F_MONITOR) - only for SP, SF, SL

The driver generates an analog output signal proportional to alternated pressure/force control; the monitor output signal can be software set to show other signals available in the driver (e.g. analog reference, force reference).

Monitor output signal is factory preset according to selected valve code, defaults are $\pm 10\text{ VDC}$ for standard and $4 \div 20\text{ mA}$ for /I option.

Output signal can be reconfigured via software selecting between voltage and current, within a maximum range of $\pm 10\text{ VDC}$ or $\pm 20\text{ mA}$.

18.7 Enable input signal (ENABLE)

To enable the driver, supply a 24 VDC on pin 6: Enable input signal allows to enable/disable the current supply to the solenoid, without removing the electrical power supply to the driver; it is used to active the communication and the other driver functions when the valve must be disabled for safety reasons. This condition **does not comply** with norms IEC 61508 and ISO 13849.

Enable input signal can be used as generic digital input by software selection.

18.8 Fault output signal (FAULT)

Fault output signal indicates fault conditions of the driver (solenoid short circuits/not connected, reference signal cable broken for $4 \div 20\text{ mA}$ input, spool position transducer cable broken, etc.). Fault presence corresponds to 0 VDC, normal working corresponds to 24 Vdc.

Fault status is not affected by the Enable input signal. Fault output signal can be used as digital output by software selection.

18.9 Remote pressure/force transducer input signal - only for SP, SF, SL

Analog remote pressure transducers or load cell can be directly connected to the driver.

Analog input signal is factory preset according to selected valve code, defaults are $\pm 10\text{ VDC}$ for standard and $4 \div 20\text{ mA}$ for /C option.

Input signal can be reconfigured via software selecting between voltage and current, within a maximum range of $\pm 10\text{ VDC}$ or $\pm 20\text{ mA}$.

Refer to pressure/force transducer characteristics to select the transducer type according to specific application requirements (see table FX500).

19 TERMINAL BOARD OVERVIEW

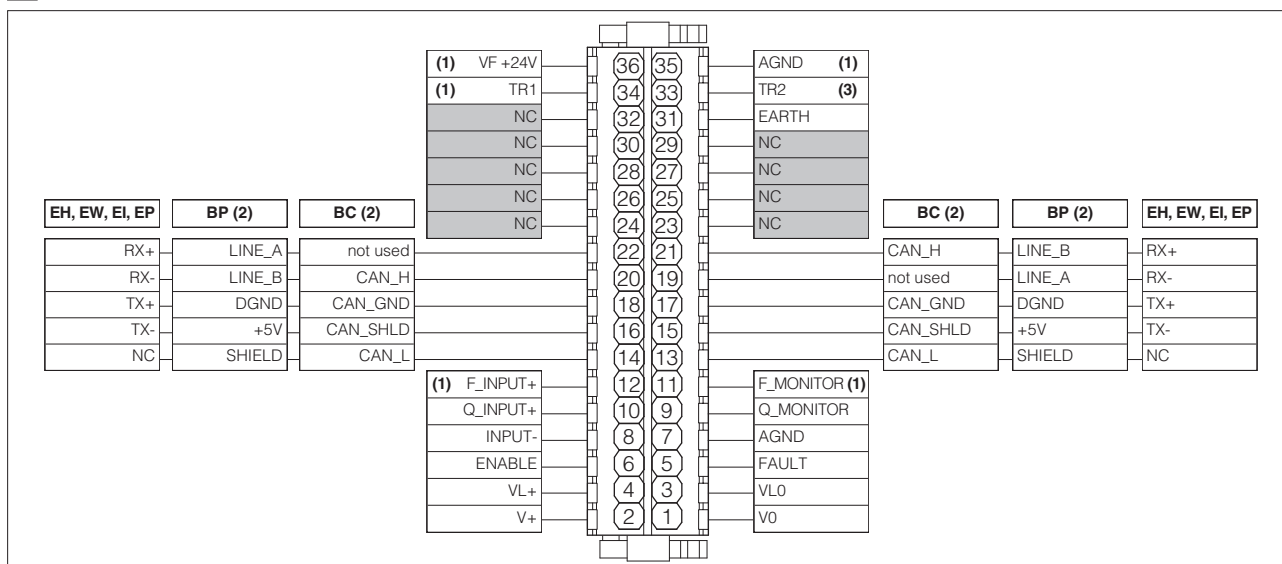

(1) connections available only **SP, SF, SL**

(2) For BC and BP executions the fieldbus connections have an internal pass-through connection

(3) connection available only **SF**

20 ELECTRONIC CONNECTIONS

20.1 Main connections signals

CABLE ENTRANCE	PIN	SIGNAL	TECHNICAL SPECIFICATIONS	NOTES
A	1	V0	Power supply 0 Vdc	Gnd - power supply
	2	V+	Power supply 24 Vdc	Input - power supply
	3	VL0	Power supply 0 Vdc for driver's logic and communication	Gnd - power supply
	4	VL+	Power supply 24 Vdc for driver's logic and communication	Input - power supply
	5	FAULT	Fault (0 Vdc) or normal working (24 Vdc), referred to VL0	Output - on/off signal
	6	ENABLE	Enable (24 Vdc) or disable (0 Vdc) the driver, referred to VL0	Input - on/off signal
	7	AGND	Analog ground	Gnd - analog signal
	8	INPUT-	Negative reference input signal for Q_INPUT+ and F_INPUT+	Input - analog signal
	9	Q_MONITOR	Flow monitor output signal: ± 10 Vdc / ± 20 mA maximum range, referred to AGND Defaults are: ± 10 Vdc for standard and $4 \div 20$ mA for /I option	Output - analog signal Software selectable
	10	Q_INPUT+	Flow reference input signal: ± 10 Vdc / ± 20 mA maximum range Defaults are: ± 10 Vdc for standard and $4 \div 20$ mA for /I option	Input - analog signal Software selectable
	11	F_MONITOR	Pressure/Force monitor output signal: ± 10 Vdc / ± 20 mA maximum range, referred to AGND (1) Defaults are: ± 10 Vdc for standard and $4 \div 20$ mA for /I option	Output - analog signal Software selectable
	12	F_INPUT+	Pressure/Force reference input signal: ± 10 Vdc / ± 20 mA maximum range (1) Defaults are: ± 10 Vdc for standard and $4 \div 20$ mA for /I option	Input - analog signal Software selectable
31	EARTH	Internally connected to driver housing		

(1) Available only for **SP, SF, SL**

20.2 USB connector - M12 - 5 pin always present

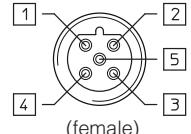
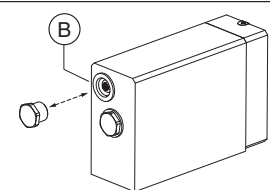
CABLE ENTRANCE	PIN	SIGNAL	TECHNICAL SPECIFICATIONS	Driver view	
B	1	+5V_USB	Power supply		
	2	ID	Identification		
	3	GND_USB	Signal zero data line		
	4	D-	Data line -		
	5	D+	Data line +		

20.3 BC fieldbus execution connections

CABLE ENTRANCE	PIN	SIGNAL	TECHNICAL SPECIFICATIONS
C1	14	CAN_L	Bus line (low)
	16	CAN_SHLD	Shield
	18	CAN_GND	Signal zero data line
	20	CAN_H	Bus line (high)
	22	not used	Pass-through connection (1)

CABLE ENTRANCE	PIN	SIGNAL	TECHNICAL SPECIFICATIONS
C2	13	CAN_L	Bus line (low)
	15	CAN_SHLD	Shield
	17	CAN_GND	Signal zero data line
	19	not used	Pass-through connection (1)
	21	CAN_H	Bus line (high)

(1) Pin 19 and 22 can be fed with external +5V supply of CAN interface

20.4 BP fieldbus execution connections

CABLE ENTRANCE	PIN	SIGNAL	TECHNICAL SPECIFICATIONS
C1	14	SHIELD	
	16	+5V	Power supply
	18	DGND	Data line and termination signal zero
	20	LINE_B	Bus line (low)
	22	LINE_A	Bus line (high)

CABLE ENTRANCE	PIN	SIGNAL	TECHNICAL SPECIFICATIONS
C2	13	SHIELD	
	15	+5V	Power supply
	17	DGND	Data line and termination signal zero
	19	LINE_A	Bus line (high)
	21	LINE_B	Bus line (low)

20.5 EH, EW, EI, EP fieldbus execution connections

CABLE ENTRANCE	PIN	SIGNAL	TECHNICAL SPECIFICATIONS
C1 (input)	14	NC	do not connect
	16	TX-	Transmitter
	18	TX+	Transmitter
	20	RX-	Receiver
	22	RX+	Receiver

CABLE ENTRANCE	PIN	SIGNAL	TECHNICAL SPECIFICATIONS
C2 (output)	13	NC	do not connect
	15	TX-	Transmitter
	17	TX+	Transmitter
	19	RX-	Receiver
	21	RX+	Receiver

20.6 Remote pressure transducer connector - only for SP, SF, SL

CABLE ENTRANCES	PIN	SIGNAL	TECHNICAL SPECIFICATIONS	NOTES	SP, SL - Single transducer (1)		SF - Double transducers (1)	
					Voltage	Current	Voltage	Current
D1	33	TR2	2nd signal transducer ± 10 Vdc / ± 20 mA maximum range	Input - analog signal Software selectable	/	/	Connect	Connect
	34	TR1	1st signal transducer ± 10 Vdc / ± 20 mA maximum range	Input - analog signal Software selectable	Connect	Connect	Connect	Connect
D2	35	AGND	Common gnd for transducer power and signals	Common gnd	Connect	/	Connect	/
	36	VF +24V	Power supply +24Vdc	Output - power supply	Connect	Connect	Connect	Connect

E-ATRA remote pressure transducer connection - see tech table GX800

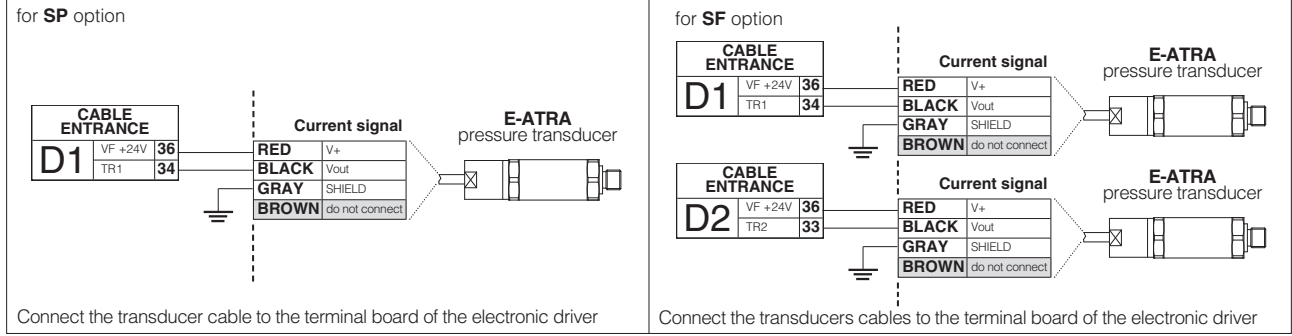

21 CONNECTIONS LAYOUT

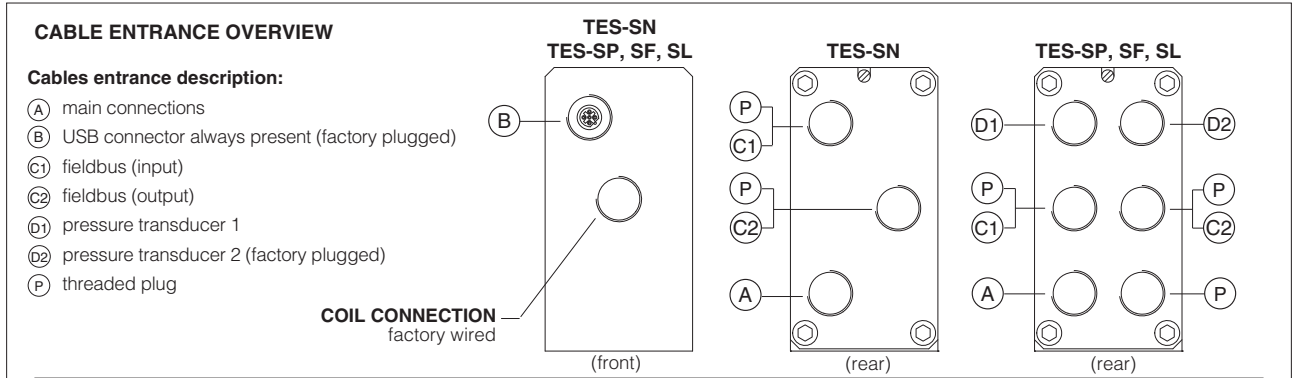

TERMINAL BOARD AND FIELDBUS TERMINATOR

Remove the 4 screws of driver's rear cover to access terminal board and fieldbus terminator

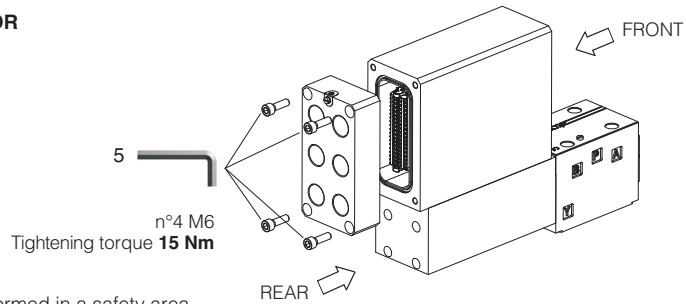

WARNING: the above operation must be performed in a safety area

Terminal board - see section 19

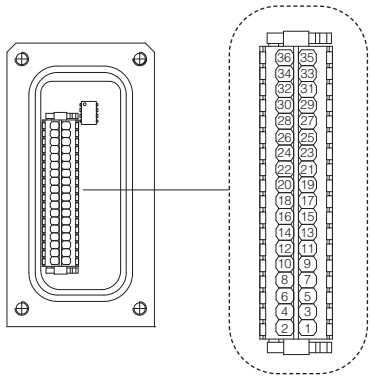

Fieldbus terminator only for BC and BP executions **(1)**

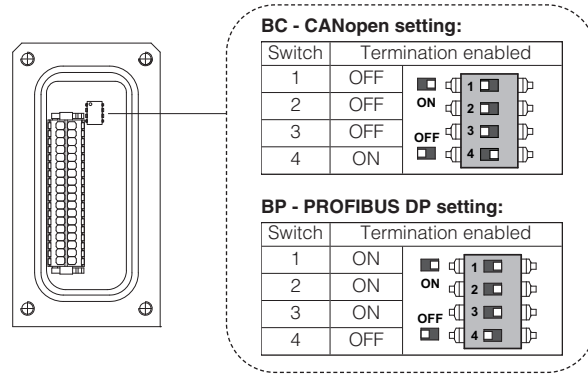

BLUETOOTH ADAPTER AND USB CONNECTOR

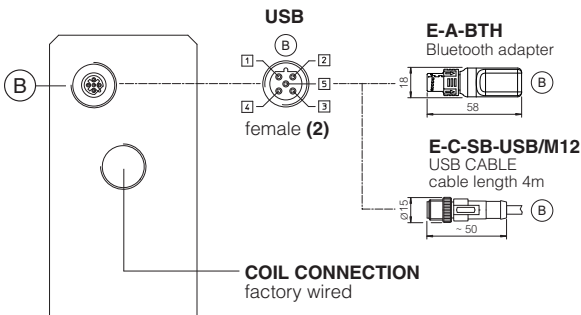

METALLIC PROTECTION CAP - supplied with the valves

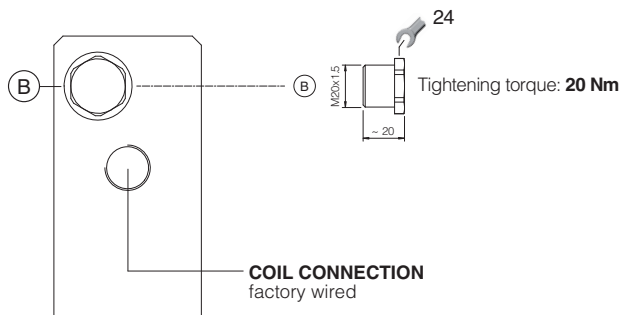

(1) Drivers with BC and BP fieldbus interface are delivered by default 'Not Terminated'. All switches are set OFF
(2) Pin layout always referred to driver's view

21.1 Cable glands and threaded plug for TES-SN - see tech table KX800

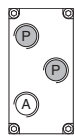
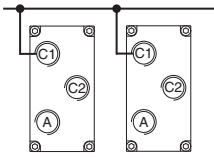
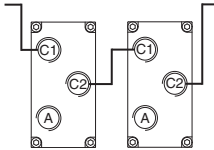

Communication interfaces	To be ordered separately				Cable entrance overview	Notes
	Cable gland quantity	entrance	Threaded plug quantity	entrance		
NP	1	A	none	none		Cable entrance A is open for costumers Cable entrance P are factory plugged
BC, BP, EH, EW, EI, EP "via stub" connection	2	C1 A	1	C2		Cable entrance A, C1, C2 are open for costumers
BC, BP, EH, EW, EI, EP "daisy chain" connection	3	C1 C2 A	none	none		Cable entrance A, C1, C2 are open for costumers

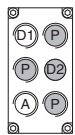
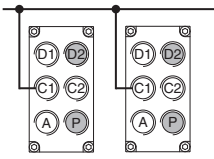
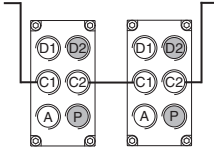
21.2 Cable glands and threaded plug for TES-SP, SF, SL - see tech table KX800

Communication interfaces	To be ordered separately				Cable entrance overview	Notes
	Cable gland quantity	entrance	Threaded plug quantity	entrance		
NP	2 (SP) 3 (SF) 2 (SL)	D1 D2 A	none	none		Cable entrance A, D1 are open for costumers Cable entrance P, D2 are factory plugged (1)
BC, BP, EH, EW, EI, EP "via stub" connection	3 (SP) 4 (SF) 3 (SL)	D1 - D2 C1 A	1	C2		Cable entrance A, C1, C2, D1 are open for costumers Cable entrance P, D2 are factory plugged (1)
BC, BP, EH, EW, EI, EP "daisy chain" connection	4 (SP) 5 (SF) 4 (SL)	D1 - D2 C1 - C2 A	none	none		Cable entrance A, C1, C2, D1 are open for costumers Cable entrance P, D2 are factory plugged (1)

(1) Remove plug D2 for second transducer connection of SF version

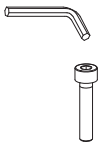
22 FASTENING BOLTS AND SEALS

	<p>DHZA</p> <p>Fastening bolts: 4 socket head screws M5x50 class 12.9 Tightening torque = 8 Nm</p>	<p>DKZA</p> <p>Fastening bolts: 4 socket head screws M6x40 class 12.9 Tightening torque = 15 Nm</p>
	<p>Seals: 4 OR 108; Diameter of ports A, B, P, T: \varnothing 7,5 mm (max) 1 OR 2025 Diameter of port Y: \varnothing = 3,2 mm (only for /Y option)</p>	<p>Seals: 5 OR 2050; Diameter of ports A, B, P, T: \varnothing 11,2 mm (max) 1 OR 108 Diameter of port Y: \varnothing = 5 mm (only for /Y option)</p>

23 INSTALLATION DIMENSIONS [mm]

DHZA-TES

ISO 4401: 2005

Mounting surface: 4401-03-02-0-05 (see table P005)

(for /Y surface: 4401-03-03-0-05 without port X)

Mass [kg]	
DHZA-TES-07	8,9

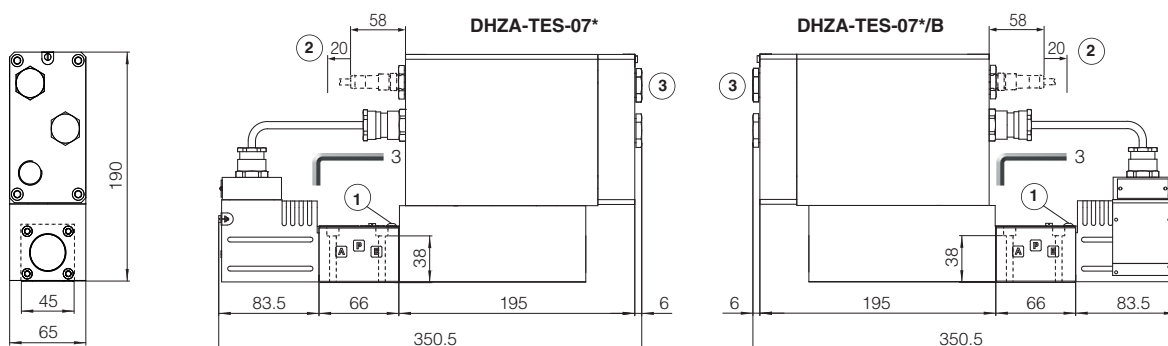

DKZA-TES

ISO 4401: 2005

Mounting surface: 4401-05-04-0-05 (see table P005)

(for /Y surface: 4401-05-05-0-05 without port X)

Mass [kg]	
DKZA-TES-17	10,7

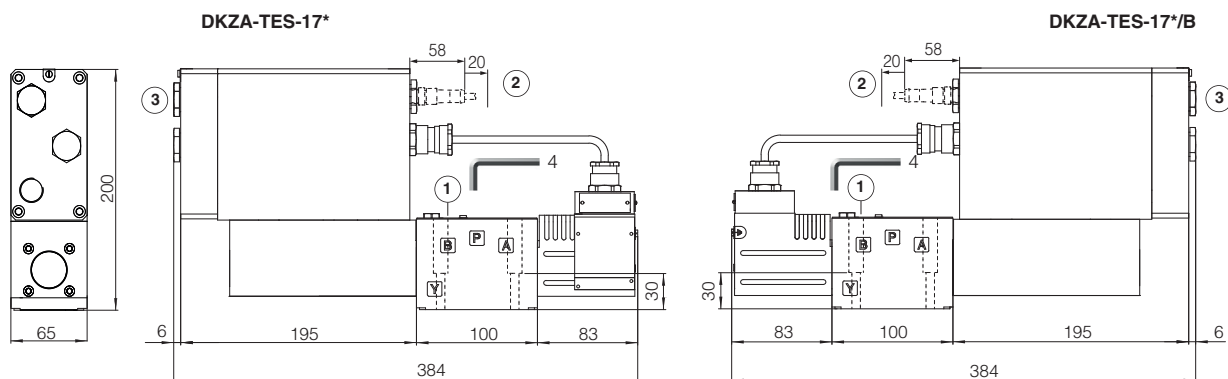

① = Air bleeding

② = Space required for connection cable and for Bluetooth adapter or USB connector removal

③ = The dimensions of cable glands must be considered (see tech table **KX800**)

24 RELATED DOCUMENTATION

X010 Basics for electrohydraulics in hazardous environments

X020 Summary of Atos ex-proof components certified to ATEX, IECEx, EAC, PESO, CCC

FX500 Ex-proof digital proportionals with p/Q control

FX620 Ex-proof servoproportionals with on-board axis card

FX900 Operating and maintenance information for ex-proof proportional valves

GS500 Programming tools

GS510 Fieldbus

GX800 Ex-proof pressure transducer type E-ATRA-7

KX800 Cable glands for ex-proof valves

P005 Mounting surfaces for electrohydraulic valves

E-MAN-RA-LES TES/LES user manual

E-MAN-RA-LES-S TES/LES with p/Q control user manual