

Ex-proof solenoid valves with spool position monitoring

on/off, direct, with inductive proximity sensor - **ATEX, IECEx, EAC, CCC** or **cULus**

Availability and price only on request

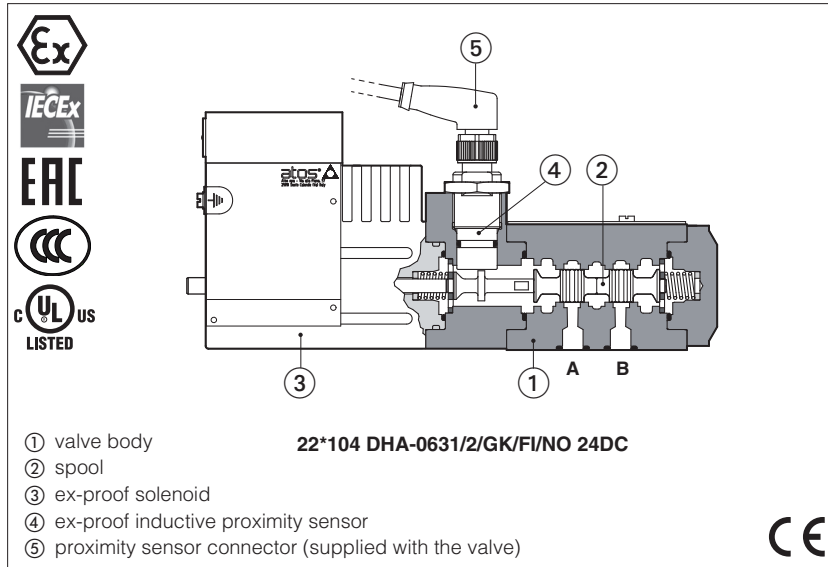

22*104 DHA

On-off, spool type directional valves equipped with ex-proof solenoids and proximity sensor for the spool position monitoring, certified for safe operation in hazardous environments with potentially explosive atmosphere.

Certifications:

- Multicertification **ATEX, IECEx, EAC, CCC** for gas group **II 2G** and dust category **II 2D**
- Certification **IECEx** for gas group **I M2** (mining)
- **cULus** North American certification for gas

Note: the valve is not certified in conformity to the Machine Directive 2006/42/CE

Size: **06** - ISO 4401

Max flow: **70 l/min**

Max pressure: **350 bar**

1 MODEL CODE OF SPOOL TYPE ON-OFF DIRECTIONAL SOLENOID VALVES

22*104	DHA	/	*	-	0	63	1/2	-	GK	/	FI	*	/	*	24DC	/*
Special execution with ex-proof proximity sensor															Voltage Code: see section 5	Seals material - = NBR PE = FKM
<p>DHA = spool type - direct</p> <p>Certification type: Multicertification ATEX, IECEx, EAC, CCC: - = omit for Group II 2G / II 2D (1) M = Group I M2 (mining) North American Certification: UL = cULus</p> <p>Valve size (ISO 4401) 0 = 06</p> <p>Configuration, see section 2 :</p> <p>Spool type, see section 2 :</p>																
<p>Options: A = solenoid at side of port B (for single solenoid valves) O = horizontal cable entrance (1) WP =  manual override protected by metallic cap</p> <p>Electrical signal: /NO = electric contact is open when the valve is de-energized</p> <p>/FI = inductive proximity sensor</p> <p>Solenoid threaded connection for cable gland fitting: GK = GK-1/2" - not for cULus (2) M = M20x1,5 - not for cULus NPT = 1/2" NPT</p>																

(1) Not for multicertification **M** group I (mining)

(2) Approved only for the Italian market

2 CONFIGURATION AND SPOOLS

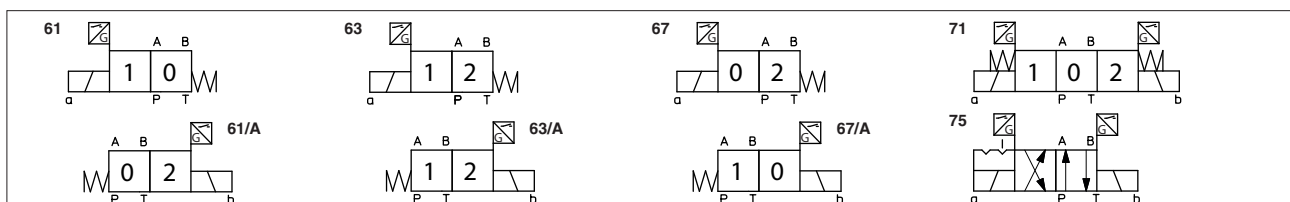

Configurations **63** is available only for spool type **0/2, 1/2** and **2/2**; Configurations **61, 67** and **71** are available only for spools **0, 1, 3** and **4**

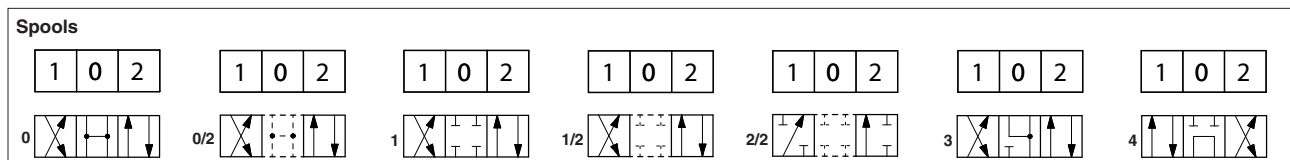

3 GENERAL CHARACTERISTICS

Assembly position / location	Any position
Subplate surface finishing to ISO 4401	Acceptable roughness index, Ra ≤0,8 recommended Ra 0,4 - flatness ratio 0,01/100
MTTFd values according to EN ISO 13849	150 years, for further details see technical table P007
Ambient temperature	Standard = -20°C ÷ +70°C /PE option = -20°C ÷ +70°C
Storage temperature range	Standard = -20°C ÷ +80°C /PE option = -20°C ÷ +80°C
Surface protection	Zinc coating with black passivation - salt spray test (EN ISO 9227) > 200h
Compliance	Explosion proof protection, see section 7 for /FI proximity sensor and section 8 for solenoid -Flame proof enclosure "Ex d" -Dust ignition protection by enclosure "Ex t" RoHS Directive 2011/65/EU as last update by 2015/863/EU REACH Regulation (EC) n°1907/2006

4 HYDRAULIC CHARACTERISTICS

Operating pressure	Ports P,A,B: 350 bar; Port T 210 bar
Rated flow	See diagrams Q/Δp at section 13
Maximum flow	70 l/min , see operating limits at section 14

5 EX PROOF SOLENOID: ELECTRICAL CHARACTERISTICS

Valve type	22*104 DHA	22*104 DHA/M	22*104 DHA/UL
Voltage code (1) VDC ±10%	12DC, 24DC, 28DC, 48DC, 110DC, 125DC, 220DC		12DC, 24DC, 110DC, 125DC, 220DC
VAC 50/60 Hz ±10%	12AC, 24AC, 110AC, 230AC		12AC, 24AC, 110AC, 230AC
Power consumption at 20°C	8W		12W
Coil insulation	class H		
Protection degree with relevant cable gland	IP66/67 to DIN EN60529		raintight enclosure, UL approved
Duty factor	100%		

(1) For alternating current supply a rectifier bridge is provided built-in the solenoid
For power supply frequency 60 Hz, the nominal supply voltage of solenoids 110AC and 230AC must be 115/60 and 240/60 respectively

6 SEALS AND HYDRAULIC FLUIDS - for other fluids not included in below table, consult our technical office

Seals, recommended fluid temperature	NBR seals (standard) = -20°C ÷ +60°C, with HFC hydraulic fluids = -20°C ÷ +50°C FKM seals (/PE option) = -20°C ÷ +80°C		
Recommended viscosity	15 ÷ 100 mm ² /s - max allowed range 2.8 ÷ 500 mm ² /s		
Fluid contamination class	ISO 4406 class 21/19/16 NAS 1638 class 10, in line filters of 25 μm (β ₂₅ ≥ 75 recommended)		
Hydraulic fluid	Suitable seals type	Classification	Ref. Standard
Mineral oils	NBR, FKM	HL, HLP, HLPD, HVLP, HVLDP	DIN 51524
Flame resistant without water	FKM	HFDU, HFDR	ISO 12922
Flame resistant with water	NBR	HFC	

7 PROXIMITY SENSOR: GENERAL CHARACTERISTICS AND CERTIFICATION DATA

SENSOR TYPE	NJ1,5-18GM-N-D-V1		
Supply voltage (1) [V]	8,2 VDC		
Current consumption [mA]	3 mA (de-energized)		1 mA (energized)
Protection degree	IP66/IP67 according to IEC 60529		
Max pressure [bar]	350		
Ambient temperature	-25 ÷ +85 °C		
Type examination certificate	<ul style="list-style-type: none"> • ATEX PTB 00 ATEX 2048 X • IECEX IECEX PTB 11.0037X • CCC 2020322315002255 • EAC TC RU C-DE.AA87.B.00394 • cULus UL-US-2019259-0 / UL-CA-2015551-0 		
Method of protection	<ul style="list-style-type: none"> • ATEX, EAC Ex ia IIC T6...T1 Ga; Ex ia IIC T6...T1 Gb; II 1 D Ex ia IIIC T200 135°C Da • IECEX Ex ia IIC T6...T1 Ga; Ex ia IIC T6...T1 Gb; Ex ia I Mb; Ex ia IIIC T200 135°C Da • CCC Ex ia IIC T1~T6 Ga; Ex ia IIC T1~T6 Gb; Ex ia IIC T1~T6 Gc; Ex iaD 20 T135; Ex ibD 21 T135 • cULus Class2 or LV/LC 		

(1) For application in explosive environments, the inductive proximity sensor must be electrically supplied by means of a galvanic insulated power amplifier (safety barrier) for intrinsically safe circuits, classified for Zone 1 and 2

8 SOLENOID CERTIFICATION DATA

Valve type	22*104 DHA		22*104 DHA/M	22*104 DHA/UL	
Certifications	Multicertification Group II ATEX, IECEX, EAC, PESO, CCC		Multicertification Group I ATEX, IECEX	North American cULus cULus	
Solenoid certified code	OA		OA/M	OA/EC	
Type examination certificate (1)	ATEX: CESI 02 ATEX 014 IECEX: IECEX CES 10.0010x EAC: RU C - IT.AЖ38.B.00425/21 PESO: P468212/2 CCC: 2020322307003240		ATEX: CESI 03 ATEX 057x IECEX: IECEX CES 12.0007x	20170324 - E366100	
Method of protection	<ul style="list-style-type: none"> • ATEX Ex II 2G Ex db IIC T6/T4/T3 Gb Ex II 2D Ex tb IIIC T85°C/T200°C Db • IECEX Ex db IIC T6/T4/T3 Gb Ex tb IIIC T85°C/T200°C Db • EAC 1Ex d IIC T6/T4/T3 Gb X Ex tb IIIC T85°C/T200°C Db X • PESO Ex db IIC T6/T4/T3 Gb • CCC Ex d IIC T6/T4/T3 Gb Ex tD A21 IP66/IP67 T85°C/T135°C/T200°C 		<ul style="list-style-type: none"> • ATEX Ex I M2 Ex db I Mb • IECEX Ex db I Mb 	<ul style="list-style-type: none"> • UL 1203 Class I, Div. I, Groups C & D Class I, Zone I, Groups IIA & IIB 	
Temperature class	T6	T4	-	T6	T5
Surface temperature	≤ 85 °C	≤ 135 °C	≤ 150 °C	≤ 85 °C	≤ 100 °C
Ambient temperature (2)	-40 ÷ +45 °C	-40 ÷ +70 °C	-20 ÷ +70 °C	-40 ÷ +55 °C	-40 ÷ +70 °C
Applicable standards	EN 60079-0 EN 60079-1 EN 60079-31		IEC 60079-0 IEC 60079-1 IEC 60079-31	UL 1203 and UL429, CSA 22.2 n°30-1986 CSA 22.2 n°139-13	
Cable entrance: threaded connection vertical (standard) or horizontal (option /O)			GK = GK-1/2" M = M20x1,5 NPT = 1/2" NPT	1/2" NPT ANSI/ASME B46.1	

(1) The type examiner certificates can be downloaded from www.atos.com

(2) The solenoids **Group II** and **cULus** are certified for minimum ambient temperature -40°C

⚠ WARNING: service work performed on the valve by the end users or not qualified personnel invalidates the certification

9 EX PROOF SOLENOIDS WIRING

Multicertification

Standard version **Option /O**

① cover with threaded connection for vertical cable gland fitting
② cover with threaded connection for horizontal cable gland fitting
③ terminal board for cables wiring
④ standard manual override
⑤ screw terminal for additional equipotential grounding

① = Coil PCB 3 poles terminal board
② = GND suitable for wires cross sections
③ = Coil up to 2,5 mm² (max AWG14)

cULus certification

Standard version **Option /O**

① cover with threaded connection for vertical cable gland fitting
② cover with threaded connection for horizontal cable gland fitting
③ terminal board for cables wiring
④ standard manual override

⚠ Pay attention to coil polarity
① = Coil + PCB 3 poles terminal board suggest-
② = GND ed cable section up to 1,5 mm² (max
③ = Coil - AWG16), see section 10 note 1

alternative GND screw terminal connected to solenoid housing

10 CABLE SPECIFICATION AND TEMPERATURE - Power supply and grounding cables have to comply with following characteristics:

Multicertification Group I and Group II	
Power supply: section of coil connection wires = 2,5 mm ²	Grounding: section of internal ground wire = 2,5 mm ² section of external ground wire = 4 mm ²
cULus certification:	
<ul style="list-style-type: none"> • Suitable for use in Class I Division 1, Gas Groups C • Armored Marine Shipboard Cable which meets UL 1309 • Tinned Stranded Copper Conductors • Bronze braided armor • Overall impervious sheath over the armor 	
Any Listed (UBVZ/UBVZ7) Marine Shipboard Cable rated 300 V min, 15A min. 3C 2,5 mm ² (14 AWG) having a suitable service temperature range of at least -25°C to +110°C	
Note 1: For Class I wiring the 3C 1,5 mm ² AWG 16 cable size is admitted only if a fuse lower than 10 A is connected to the load side of the solenoid wiring.	

10.1 Cable temperature

The cable must be suitable for the working temperature as specified in the "safety instructions" delivered with the first supply of the products.

Multicertification

Max ambient temperature [°C]	Temperature class		Max surface temperature [°C]		Min cable temperature
	Group I	Group II	Group I	Group II	
45 °C	-	T6	150 °C	85 °C	not prescribed
70 °C	-	T4	150 °C	135 °C	90 °C

cULus certification

Max ambient temperature [°C]	Temperature class	Max surface temperature [°C]	Min cable temperature
55 °C	T6	85 °C	100 °C
70 °C	T5	100 °C	100 °C

11 CABLE GLANDS only for Multicertification

Cable glands with threaded connections GK-1/2", 1/2"NPT or M20x1,5 for standard or armoured cables have to be ordered separately, see tech. table **KX800**

Note: a Loctite sealant type 545, should be used on the cable gland entry threads

12 PROXIMITY SENSOR CONNECTION

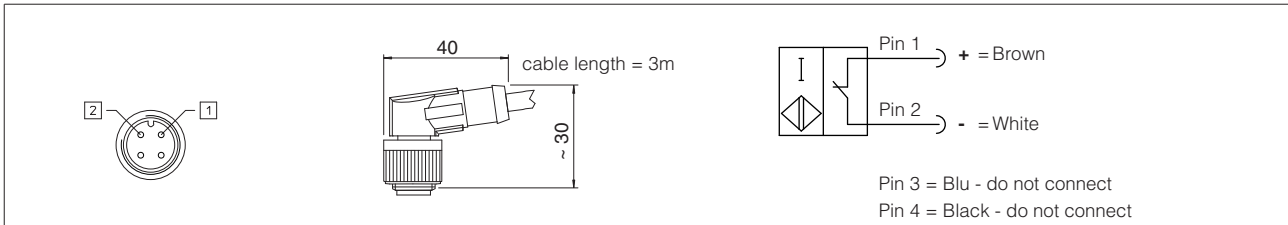

13 Q/Δp DIAGRAMS (based on mineral oil ISO VG 46 at 50°C)

Spool type	Flow direction				
	P→A	P→B	A→T	B→T	P→T
0	A	A	B	B	C
1	C	B	B	B	
3	C	C	A	A	
4	E	E	F	B	D
1/2, 0/2	C	C	C	C	
2/2	E	E			

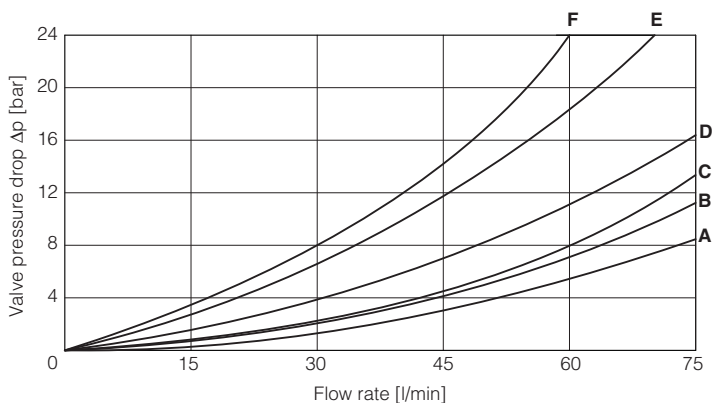

14 OPERATING LIMITS (based on mineral oil ISO VG 46 at 50°C)

The diagram have been obtained with warm solenoids and power supply at lowest value ($V_{nom}-10\%$). The curves refer to application with symmetrical flow through the valve (i.e. P→A and B→T). In case of asymmetric flow the operating limits must be reduced.

Spool type	diagram
0, 1	A
0/2, 1/2, 3	B
2/2, 4	C

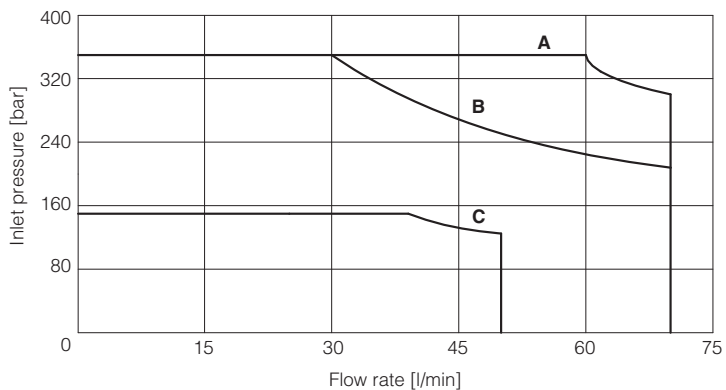

15 FASTENING BOLTS AND SEALS

	<p>Fastening bolts: 4 socket head screws M5x50 class 12.9 Tightening torque = 8 Nm</p>
	<p>Seals: 4 OR 108 Diameter of ports A, B, P, T: Ø 7,5 mm (max)</p>

16 INSTALLATION DIMENSIONS

ISO 4401: 2005 (see table P005)
 Mounting surface: 4401-03-02-0-05

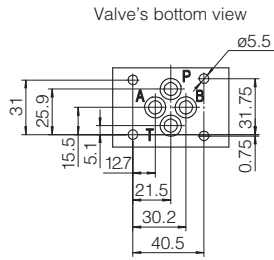

P = PRESSURE PORT
A, B = USE PORT
T = TANK PORT

22*104 DHA-06*

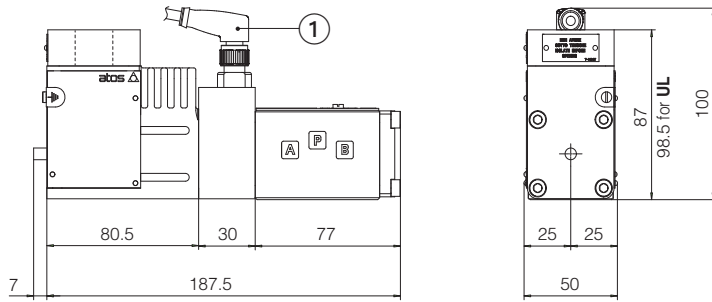

22*104 DHA-06*/A

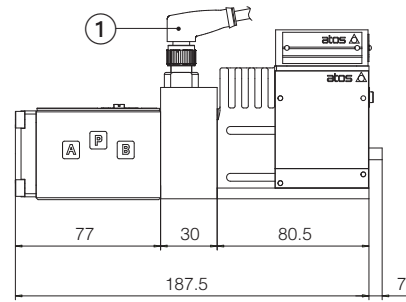

22*104 DHA-07*

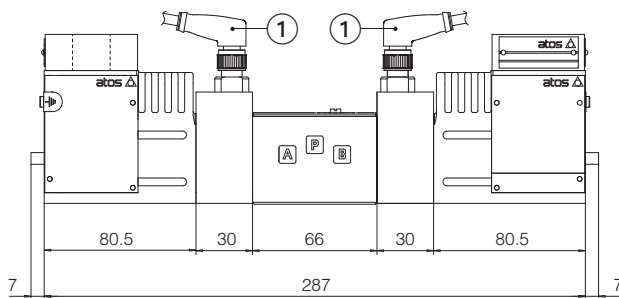

Mass [kg]	
22*104 DHA-06	3,15
22*104 DHA-07	5,3
Option /O	+0,35
Option /WP	+0,25

① Proximity sensor connector (cable length 3m) supplied with the valve

option /O

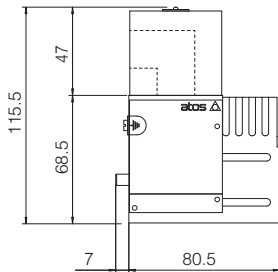

option /WP

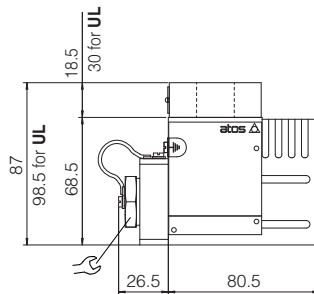

option /OWP

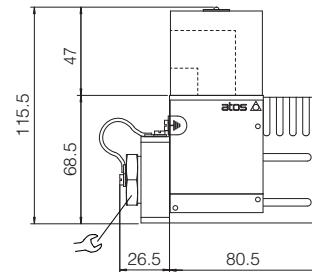

17 RELATED DOCUMENTATION

X010 Basics for electrohydraulics in hazardous environments
X020 Summary of Atos ex-proof components certified to ATEX, IECEx, EAC, CCC, PESO
X030 Summary of Atos ex-proof components certified to cULus

EX900 Operating and maintenance information for ex-proof on-off valves
KX800 Cable glands for ex-proof valves
P005 Mounting surfaces for electrohydraulic valves