

Digital proportional directional valves high performance

direct, with on-board driver, LVDT transducer and positive spool overlap

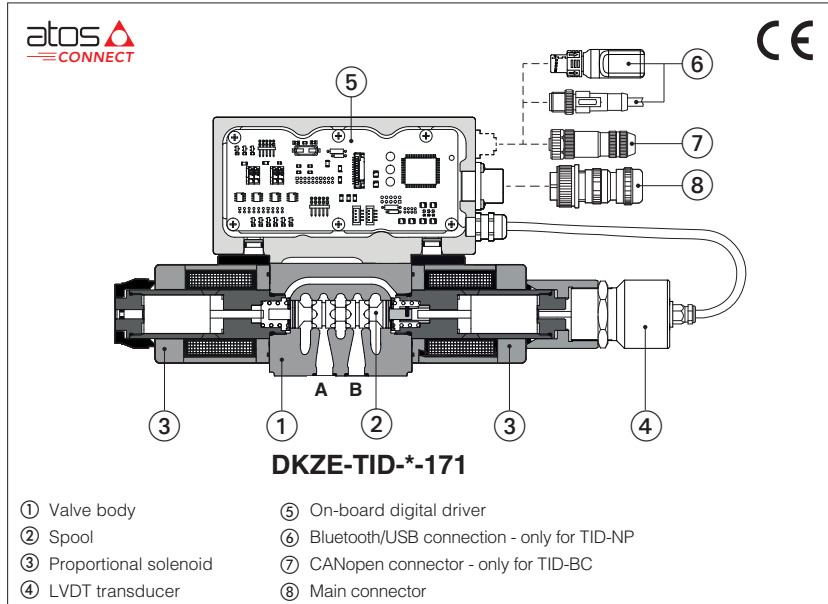

DHZE-TID, DKZE-TID

Digital high performances proportional directional valves, direct, with LVDT position transducer and positive spool overlap for directional controls and not compensated flow regulations.

TID on-board digital driver performs the valve's hydraulic regulation according to the reference signal, analog for TID-NP or CANopen for TID-BC.

For **TID-NP**, Bluetooth/USB connection is always present for valve settings via mobile App and Atos PC software.

For **TID-BC**, CANopen interface is always present for valve settings via fieldbus and Atos PC software.

The LVDT transducer grants high regulation accuracy and response sensitivity.

With de-energized proportional solenoids, the mechanical central position of the spool is performed by centering springs.

DHZE:

Size: **06** - ISO 4401
4/3 and 4/2 way
Max flow: **80 l/min**
Max pressure: **350 bar**

DKZE:

Size: **10** - ISO 4401
4/3 and 4/2 way
Max flow: **180 l/min**
Max pressure: **315 bar**

1 MODEL CODE

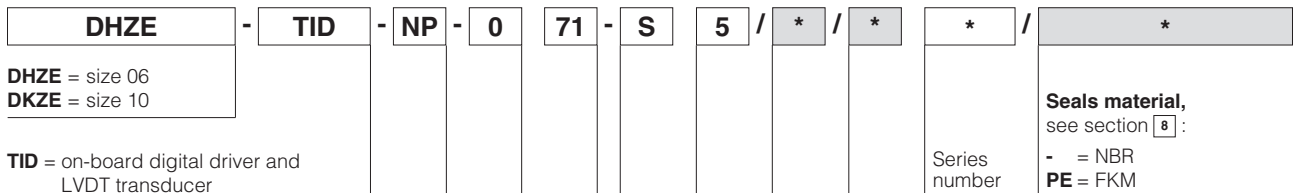

Fieldbus interfaces:

NP = Not present (USB port available)
BC = CANopen (USB port not available) (1)

Valve size ISO 4401:

0 = 06 **1** = 10

Configuration: Standard

Option /B

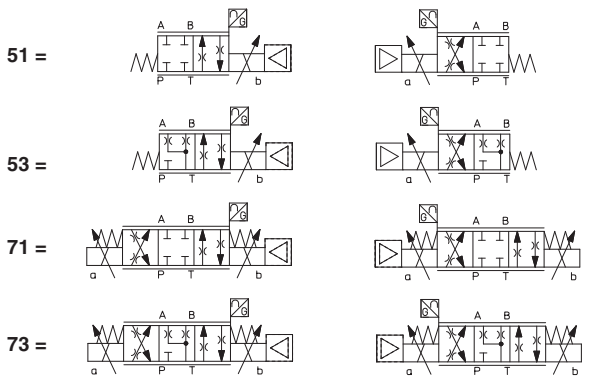

Bluetooth option (2), only for TID-NP, see section 4:
T = Bluetooth adapter supplied with the valve

Hydraulic options (2):

B = on-board digital driver, connectors and LVDT position transducer at side of port A

Electronic options, only for TID-NP (2):

I = current reference input and monitor 4÷20mA
J = current reference input 4÷20mA and voltage monitor ±10 VDC

Spool size: **3** (L,S,D) **5** (L,S,D)

DHZE = 18 28

DKZE = 45 75

Nominal flow (l/min) at Δp 10 bar P-T (see section 6)

Spool type, regulating characteristics, see section 9:

L = linear

S = progressive

D = differential-progressive

P-A = Q, B-T = Q/2

P-B = Q/2, A-T = Q

(1) Reference and monitor signals only via CANopen (analog signals not available)

(2) Possible combined options: /BI, /BJ (/T Bluetooth adapter option can be combined with all other options)

2 GENERAL NOTES

Atos digital proportionals valves are CE marked according to the applicable directives (e.g. Immunity and Emission EMC Directive). Installation, wirings and start-up procedures must be performed according to the general prescriptions shown in tech table **FS900** and in the user manuals included in the E-SW-SETUP programming software.

3 VALVE SETTINGS AND PROGRAMMING TOOLS - see tech. table **GS500**

3.1 TID-NP

Atos CONNECT mobile App

Free downloadable App for smartphones and tablets which allows quick access to valve main functional parameters and basic diagnostic information via Bluetooth, thus avoiding physical cable connection and significantly reducing commissioning time.

Atos CONNECT supports Atos digital valve drivers equipped with E-A-BTH adapter or with built-in Bluetooth. It does not support valves with p/Q control or axis controls.



E-SW-SETUP PC software

Free downloadable software for PC allows to set all valve functional parameters and to access complete diagnostic information of digital valve drivers via Bluetooth/USB service port.

Atos E-SW-SETUP PC software supports all Atos digital valve drivers and it is available at www.atos.com in MyAtos area.



WARNING: drivers USB port is not isolated! For E-C-SB-USB/M12 cable, the use of E-A-SB-USB/OPT isolator adapter is highly recommended for PC protection

Bluetooth or USB connection

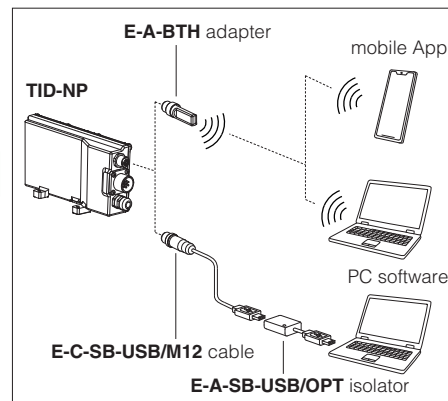

3.2 TID-BC

E-SW-SETUP PC software

Free downloadable software for PC allows to set all valve functional parameters and to access complete diagnostic information of digital valve drivers via CANopen connector.

Atos E-SW-SETUP PC software supports all Atos digital valve drivers and it is available at www.atos.com in MyAtos area.

CANopen connection

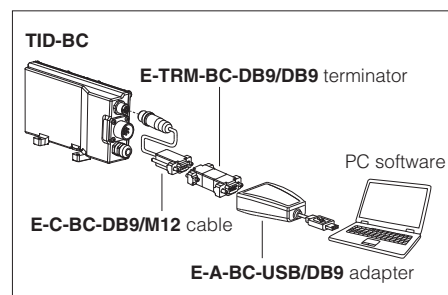

4 BLUETOOTH OPTION - only for TID-NP - see tech. table **GS500**

T option adds Bluetooth® connectivity to Atos valve drivers thanks to E-A-BTH adapter, which can be left permanently installed on-board, to allow the Bluetooth connection with the valve drivers at any time. E-A-BTH adapter can also be purchased separately and used to connect with any supported Atos digital product.

Bluetooth connection to the valve can be protected against unauthorised access by setting a personal password. The adapter leds visually indicates the status of valve driver and Bluetooth connection.



WARNING: for the list of countries where the Bluetooth adapter has been approved, see tech. table **GS500**
T option is not available for the Indian market, so the Bluetooth adapter must be ordered separately.

5 GENERAL CHARACTERISTICS

Assembly position	Any position
Subplate surface finishing to ISO 4401	Acceptable roughness index: Ra ≤ 0,8, recommended Ra 0,4 – Flatness ratio 0,01/100
MTTFd valves according to EN ISO 13849	150 years, for further details see technical table P007
Ambient temperature range	Standard = -20°C ÷ +60°C /PE option = -20°C ÷ +60°C
Storage temperature range	Standard = -20°C ÷ +70°C /PE option = -20°C ÷ +70°C
Surface protection	Zinc coating with black passivation (body), tin plating (driver housing)
Corrosion resistance	Salt spray test (EN ISO 9227) > 200 h
Vibration resistance	See technical table G004
Conformity	CE according to EMC directive 2014/30/EU (Immunity: EN 61000-6-2; Emission: EN 61000-6-3) RoHS Directive 2011/65/EU as last update by 2015/863/EU REACH Regulation (EC) n°1907/2006

6 HYDRAULIC CHARACTERISTICS - based on mineral oil ISO VG 46 at 50 °C

Valve model	DHZE							DKZE											
	ports P, A, B = 350; T = 210							ports P, A, B = 315; T = 210											
Pressure limits [bar]	ports P, A, B = 350; T = 210							ports P, A, B = 315; T = 210											
Spool type and size (1)	L3, S3		D3		L5, S5		D5		L3, S3		D3		L5, S5		D5				
Nominal flow Δp P-T (2) [l/min]	Δp= 10 bar	P-A	P-B	28	P-A	P-B	45	P-A	P-B	130	P-A	P-B	170	P-A	P-B				
		A-T	B-T		A-T	B-T		A-T	B-T		A-T	B-T		A-T	B-T	A-T	B-T	A-T	B-T
		18	9		28	14		45	22		75	37		120	60	170	85	170	85
		30	15		50	25		80	40		130	65		180	90	180	90	180	90
	Δp= 30 bar	30	15	50	50	25	80	80	40	130	130	65	170	170	85				
	Δp= 70 bar	45	22	75	75	37	120	120	60	170	170	85	170	170	85				
	Max permissible flow	50	25	80	80	40	130	130	65	180	180	90	180	180	90				
Leakage [cm³/min]	<30 (at p = 100 bar); <135 (at p = 350 bar)							<80 (at p = 100 bar); <600 (at p = 315 bar)											
Response time (3) [ms]	≤ 15							≤ 20											
Hysteresis	≤ 0,2 [% of max regulation]																		
Repeatability	± 0,1 [% of max regulation]																		
Thermal drift	zero point displacement < 1% at ΔT = 40°C																		

(1) For spool type **D*** the flow value is referred to Δp/2 per control edge

(2) For different Δp, the max flow is in accordance to the diagrams in section 9.2

(3) 0-100% step signal

7 ELECTRICAL CHARACTERISTICS

Power supplies	Nominal : +24 VDC Rectified and filtered : VRMS = 20 ÷ 32 VMAX (ripple max 10 % VPP)
Max power consumption	50 W
Max. solenoid current	DHZE = 2,6 A DKZE = 3 A
Coil resistance R at 20°C	DHZE = 3,1 Ω DKZE = 3,2 Ω
Analog input signals (1)	Voltage: range ±10 VDC (24 VMAX tolerant) Input impedance: Ri > 50 kΩ Current: range ±20 mA Input impedance: Ri = 500 Ω
Monitor outputs (1)	Output range: voltage ±10 VDC @ max 5 mA current ±20 mA @ max 500 Ω load resistance
Alarms	Solenoid not connected/short circuit, cable break with current reference signal (1), over/under temperature, valve spool transducer malfunctions, alarms history storage function
Insulation class	H (180°) Due to the occurring surface temperatures of the solenoid coils, the European standards ISO 13732-1 and EN982 must be taken into account
Protection degree to DIN EN60529	IP66 / IP67 with mating connectors
Duty factor	Continuous rating (ED=100%)
Additional characteristics	Short circuit protection of solenoid's current supply; spool position control by P.I.D. with rapid solenoid switching; protection against reverse polarity of power supply
Communication interface	USB - Atos ASCII coding CANopen - EN50325-4 + DS408
Communication physical layer	not insulated - USB 2.0 + USB OTG optical insulated - CAN ISO11898
Recommended wiring cable	LiYCY shielded cables, see section 15

(1) Available only for TID-NP

Note: a maximum time of 500 ms (depending on communication type) has to be considered between the driver energizing with the 24 Vdc power supply and when the valve is ready to operate. During this time the current to the valve coils is switched to zero.

8 SEALS AND HYDRAULIC FLUID - for other fluids not included in below table, consult Atos Technical Office

Seals, recommended fluid temperature	NBR seals (standard) = -20°C ÷ +60°C, with HFC hydraulic fluids = -20°C ÷ +50°C FKM seals (/PE option) = -20°C ÷ +80°C		
Recommended viscosity	20 ÷ 100 mm ² /s - max allowed range 15 ÷ 380 mm ² /s		
Max fluid contamination level	normal operation	ISO4406 class 18/16/13 NAS1638 class 7	see also filter section at www.atos.com or KTF catalog
	longer life	ISO4406 class 16/14/11 NAS1638 class 5	
Hydraulic fluid	Suitable seals type	Classification	Ref. Standard
Mineral oils	NBR, FKM	HL, HLP, HLPD, HVLP, HVLPD	DIN 51524
Flame resistant without water	FKM	HFDU, HFDR	ISO 12922
Flame resistant with water	NBR	HFC	

9 DIAGRAMS (based on mineral oil ISO VG 46 at 50 °C)

9.1 Regulation diagrams - values measure at Δp 30 bar P-T

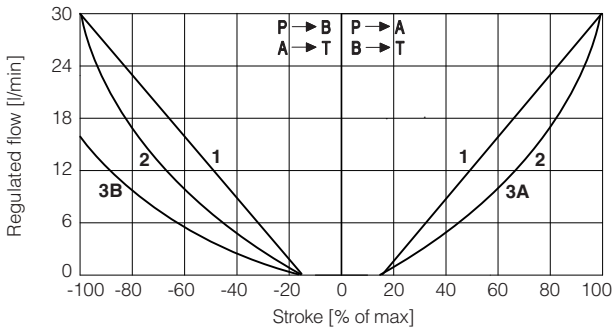

DHZE
1 = L3 **2** = S3 **3A** = D3 (P → A, A → T)
3B = D3 (P → B, B → T)

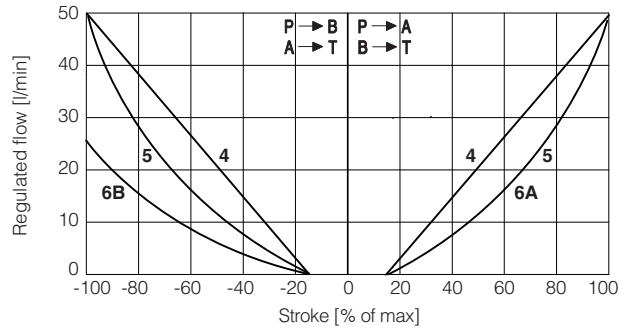

DHZE
4 = L5 **5** = S5 **6A** = D5 (P → A, A → T)
6B = D5 (P → B, B → T)

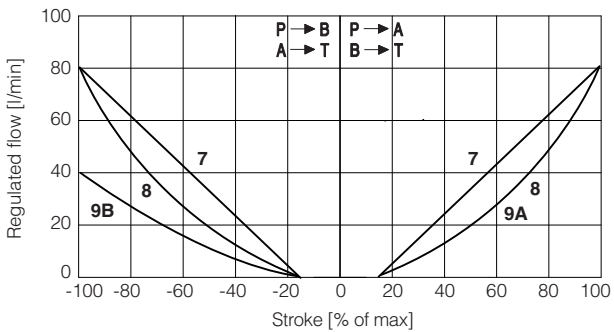

DKZE
7 = L3 **8** = S3 **9A** = D3 (P → A, A → T)
9B = D3 (P → B, B → T)

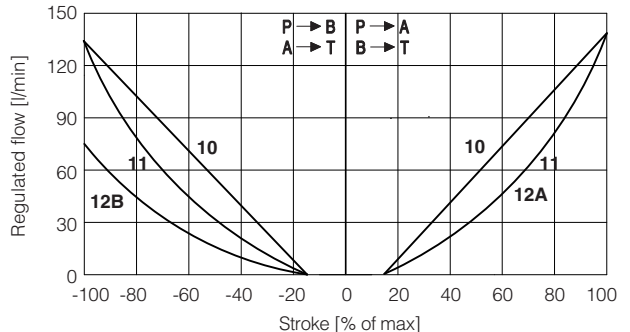

DKZE
10 = L5 **11** = S5 **12A** = D5 (P → A, A → T)
12B = D5 (P → B, B → T)

Note: Hydraulic configuration vs. reference signal for configuration 71 and 73 (standard and option /B)

Reference signal $\left. \begin{matrix} 0 \div +10 \text{ V} \\ 12 \div 20 \text{ mA} \end{matrix} \right\} P \rightarrow A / B \rightarrow T$ Reference signal $\left. \begin{matrix} 0 \div -10 \text{ V} \\ 12 \div 4 \text{ mA} \end{matrix} \right\} P \rightarrow B / A \rightarrow T$

9.2 Operating limits

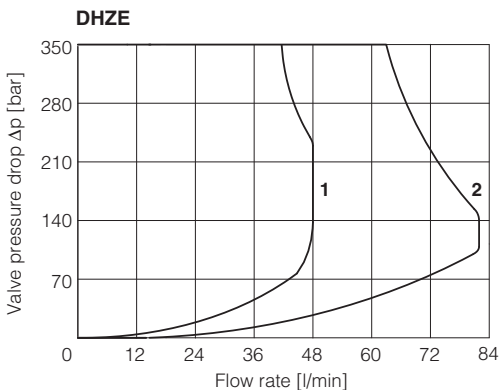

1 = spool L3, S3, D3 **2** = spool L5, S5, D5

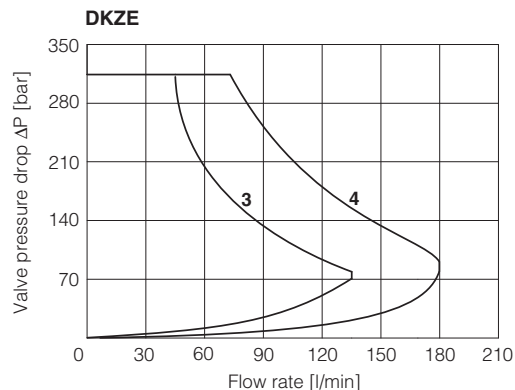

3 = spool S3, L3, D3 **4** = spool S5, L5, D5

10 HYDRAULIC OPTIONS

B = Configurations 51, 53: solenoid, on-board digital driver connectors and LVDT transducer at side of port A.
Configurations 71, 73: on-board digital driver connections and LVDT transducer at side of port A.
For hydraulic configuration vs reference signal, see 9.1

11 ELECTRONIC OPTIONS - only for TID-NP

I = This option provides 4 ÷ 20 mA current reference and monitor signals, instead of the standard ±10 VDC.
It is normally used in case of long distance between the machine control unit and the valve or where the reference signal can be affected by electrical noise; the valve functioning is disabled in case of reference signal cable breakage.

J = This option provides 4 ÷ 20 mA current reference and ±10 VDC voltage monitor signals.
The valve functioning is disabled in case of reference signal cable breakage.

12 POSSIBLE COMBINED OPTIONS

/BI, /BJ

Note: /T Bluetooth adapter option can be combined with all other options

13 POWER SUPPLY AND SIGNALS SPECIFICATIONS

13.1 Power supply (V+ and V0)

The power supply must be appropriately stabilized or rectified and filtered: apply at least a 10000 µF/40 V capacitance to single phase rectifiers or a 4700 µF/40 V capacitance to three phase rectifiers.

 A safety fuse is required in series to the power supply: 2,5 A time lag fuse.

13.2 Flow reference input signal (Q_INPUT+) - only for TID-NP

The driver controls in closed loop the valve spool position proportionally to the external reference input signal.
Standard (voltage reference input): default is ±10 VDC and can be reconfigured via software, within a maximum range of ±10 Vdc.
Options /I and /J (current reference input): default is 4 ÷ 20 mA and can be reconfigured via software, within a maximum range of ± 20 mA.

13.3 Flow monitor output signal (Q_MONITOR) - only for TID-NP

The driver generates an analog output signal proportional to the actual spool position of the valve; the monitor output signal can be software set to show other signals available in the driver.
Standard and option /J (voltage monitor output): default is ±10 Vdc and can be reconfigured via software, within a maximum range of ±10 VDC.
Option /I (current monitor output): default is 4 ÷ 20 mA and can be reconfigured via software, within a maximum range of ± 20 mA.

Note:

monitor output signal must not be directly used to activate safety functions, like to switch-ON/OFF the machine's safety components, as prescribed by the European standards (Safety requirements of fluid technology systems and components-hydraulics, ISO 4413).

14 ELECTRONIC CONNECTIONS

14.1 Main connector signals - 7 pin (A1) (A2)

PIN	TID-NP	TID-BC	TECHNICAL SPECIFICATIONS	NOTES
A	V+		Power supply 24 Vdc	Input - power supply
B	V0		Power supply 0 Vdc	Gnd - power supply
C	AGND	(1)	Analog ground	Gnd - analog signal
D	Q_INPUT+	(1)	Flow reference input signal: ±10 Vdc for standard, 4 ÷ 20 mA for /I and /J options	Input - analog signal
E	INPUT-	(1)	Negative reference input signal for Q_INPUT+	Input - analog signal
F	Q_MONITOR	(1)	Flow monitor output signal: ±10 Vdc for standard and /J option, 4 ÷ 20 mA for /I option, referred to AGND	Output - analog signal
G	EARTH		Internally connected to driver housing	

(1) Do not connect for TID-BC

14.2 USB connector - M12 5 pin (B) - only for TID-NP

PIN	SIGNAL	TECHNICAL SPECIFICATION (1)
1	+5V_USB	Power supply
2	ID	Identification
3	GND_USB	Signal zero data line
4	D-	Data line -
5	D+	Data line +

(1) Shield connection on connector housing is recommended

14.3 CANopen connector - M12 - 5 pin (C) - only for TID-BC

PIN	SIGNAL	TECHNICAL SPECIFICATION (1)
1	CAN_SHLD	Shield
2	not used	-
3	CAN_GND	Signal zero data line
4	CAN_H	Bus line (high)
5	CAN_L	Bus line (low)

(1) Shield connection on connector housing is recommended

14.4 Connections layout

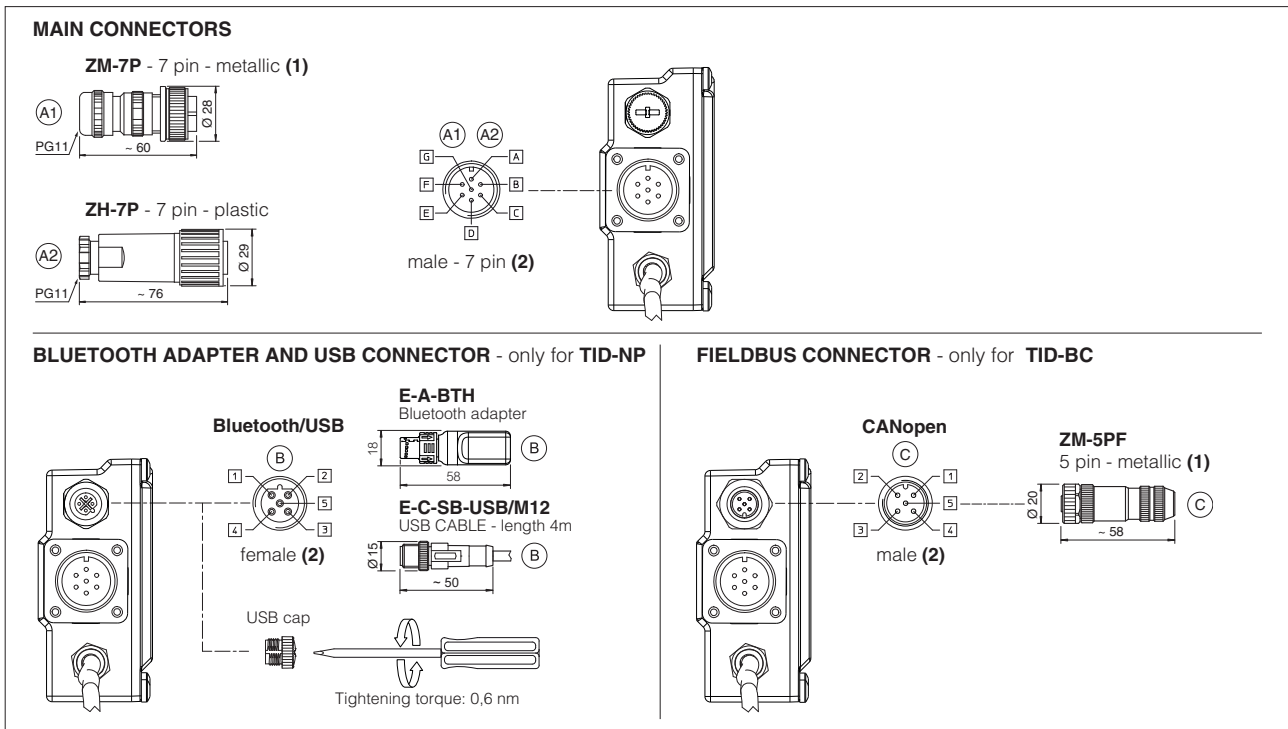

(1) use of metallic connectors is strongly recommended in order to fulfill EMC requirements (2) pin layout always referred to driver's view

15 CONNECTORS CHARACTERISTICS - to be ordered separately

15.1 Main connectors - 7 pin

CONNECTOR TYPE	POWER SUPPLY AND SIGNALS	POWER SUPPLY AND SIGNALS
CODE	(A1) ZM-7P	(A2) ZH-7P
Type	7pin female straight circular	7pin female straight circular
Standard	According to MIL-C-5015	According to MIL-C-5015
Material	Metallic	Plastic reinforced with fiber glass
Cable gland	PG11	PG11
Recommended cable	LiYCY 7 x 0,75 mm ² max 20 m (logic and power supply) or LiYCY 7 x 1 mm ² max 40 m (logic and power supply)	LiYCY 7 x 0,75 mm ² max 20 m (logic and power supply) or LiYCY 7 x 1 mm ² max 40 m (logic and power supply)
Conductor size	up to 1 mm ² - available for 7 wires	up to 1 mm ² - available for 7 wires
Connection type	to solder	to solder
Protection (EN 60529)	IP 67	IP 67

15.2 Fieldbus communication connector - only for TID-BC

CONNECTOR TYPE	CANopen
CODE	(C) ZM-5PF
Type	5 pin female straight circular
Standard	M12 coding A – IEC 61076-2-101
Material	Metallic
Cable gland	Pressure nut - cable diameter 6÷8 mm
Cable	CANbus Standard (DR 303-1)
Connection type	screw terminal
Protection (EN 60529)	IP67

16 FASTENING BOLTS AND SEALS

	DHZE	DKZE
	<p>Fastening bolts:</p> <p>4 socket head screws M5x30 class 12.9</p> <p>Tightening torque = 8 Nm</p>	<p>Fastening bolts:</p> <p>4 socket head screws M6x40 class 12.9</p> <p>Tightening torque = 15 Nm</p>
	<p>Seals:</p> <p>4 OR 108</p> <p>Diameter of ports A, B, P, T: Ø 7,5 mm (max)</p>	<p>Seals:</p> <p>5 OR 2050</p> <p>Diameter of ports A, B, P, T: Ø 11,2 mm (max)</p>

DHZE-TID-*-05

ISO 4401: 2000
 Mounting surface: 4401-03-02-0-05
 (see table P005)

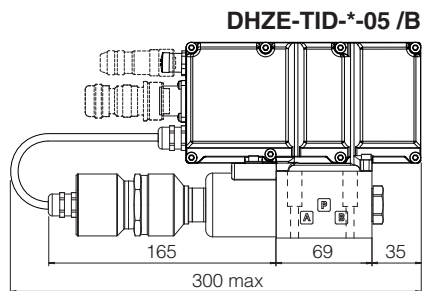
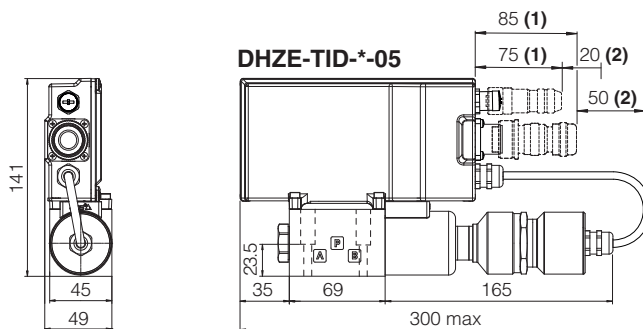

DHZE-*-05	Mass [kg]
all versions	2,5

- (1) The indicated dimension refers to the longer connectors or Bluetooth adapter
 For dimensions of connectors and Bluetooth adapter, see section 14.4
- (2) Space required for connection cable and for connector removal

DHZE-TID-*-07

ISO 4401: 2000
 Mounting surface: 4401-03-02-0-05
 (see table P005)

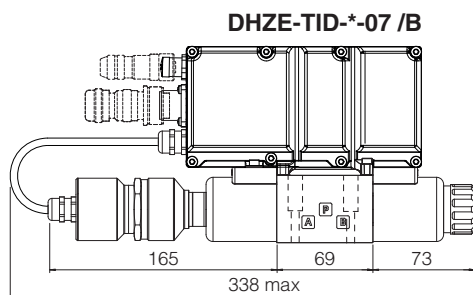
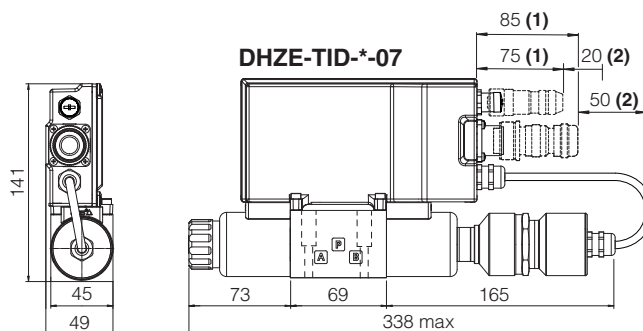

DHZE-*-07	Mass [kg]
all versions	3

- (1) The indicated dimension refers to the longer connectors or Bluetooth adapter
 For dimensions of connectors and Bluetooth adapter, see section 14.4
- (2) Space required for connection cable and for connector removal

DKZE-TID-*-15

ISO 4401: 2000

Mounting surface: 4401-05-04-0-05
(see table P005)

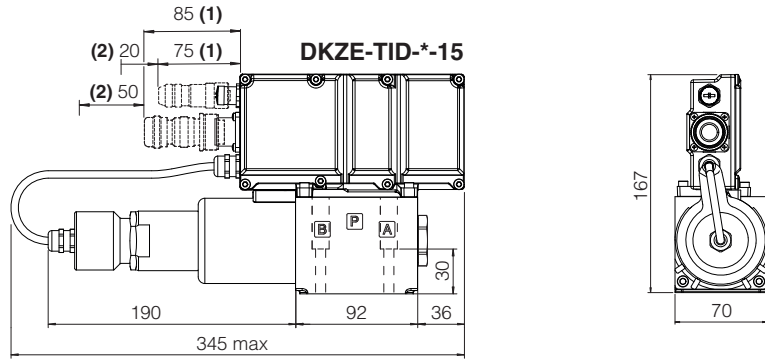

DKZE-TID-*-15 /B

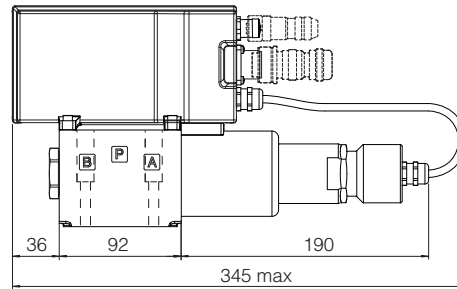

DKZE-*-15	Mass [kg]
all versions	5,5

- (1) The indicated dimension refers to the longer connectors or Bluetooth adapter
For dimensions of connectors and Bluetooth adapter, see section 14.4
(2) Space required for connection cable and for connector removal

DKZE-TID-*-17

ISO 4401: 2000

Mounting surface: 4401-03-02-0-05
(see table P005)

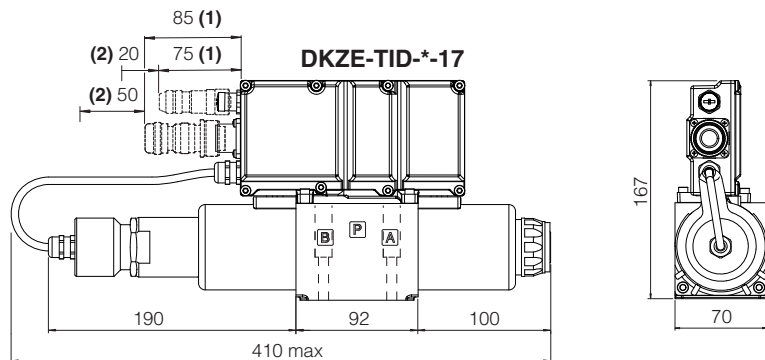

DKZE-TID-*-17 /B

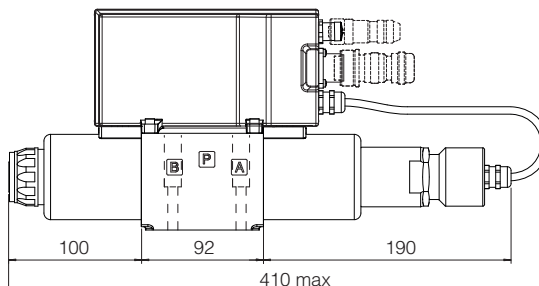

DHZE-*-17	Mass [kg]
all versions	7,1

- (1) The indicated dimension refers to the longer connectors or Bluetooth adapter
For dimensions of connectors and Bluetooth adapter, see section 14.4
(2) Space required for connection cable and for connector removal

18 RELATED DOCUMENTATION

FS001	Basics for digital electrohydraulics	K800	Electric and electronic connectors
FS900	Operating and maintenance information for proportional valves	P005	Mounting surfaces for electrohydraulic valves
GS500	Programming tools	QD300	Quickstart for TID valves commissioning
GS510	Fieldbus	E-MAN-RI-TID	TID user manual