

Ex-proof proportional directional valves

piloted, without transducer and with positive spool overlap - **ATEX, IECEX, EAC, PESO, CCC** or **cULus**

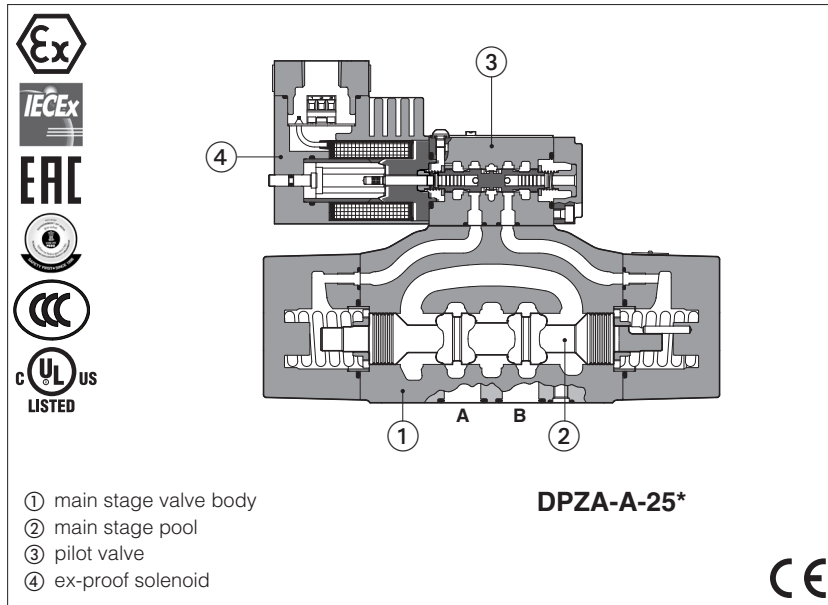

DPZA-A

Ex-proof proportional valves, piloted, without position transducer and with positive spool overlap, for open loop directional controls and not compensated flow regulations.

They are equipped with ex-proof proportional solenoids certified for safe operations in hazardous environments with potentially explosive atmosphere.

Certifications:

- Multicertification **ATEX, IECEX, EAC, PESO, CCC** for gas group **II 2G** and dust category **II 2D**
- Multicertification **ATEX, IECEX**, for gas group **I M2** (mining)
- **cULus** North American certification for gas group **C&D**

The flameproof enclosure of solenoid prevents the propagation of accidental internal sparks or fire to the external environment.

The solenoid is also designed to limit the surface temperature within the classified limits.

Size: **10 ÷ 32** - ISO 4401

Max flow: **180 ÷ 1500 l/min**

Max pressure: **350 bar**

1 MODEL CODE

DPZA	/	*	-	A	-	2	71	-	L	5	-	GK	/	*	/	*	/	*
Ex-proof proportional directional valve, piloted																		
Certification type: Multicertification ATEX, IECEX, EAC, PESO, CCC: - = omit for Group II 2G / 2D (1) M = Group IM2 (mining) North American Certification: UL = cULus																		
A = without transducer																		
Valve size ISO 4401: 1 = 10 2 = 16 4 = 25 6 = 32																		
Seals material, see section 6: - = NBR PE = FKM BT = HNBR (2)																		
Voltage code: - = standard coil for 24 Vdc Atos drivers 24 = optional coil for 24 Vdc low current drivers																		
Options (3): B = solenoid at side of port A D = internal drain E = external pilot pressure G = pressure reducing valve for piloting O = horizontal cable entrance (2) WP = manual override protected by metallic cap																		
Solenoid threaded connection for cable gland fitting: GK = GK-1/2" - not for cULus M = M20x1,5 - not for cULus NPT = 1/2" NPT																		

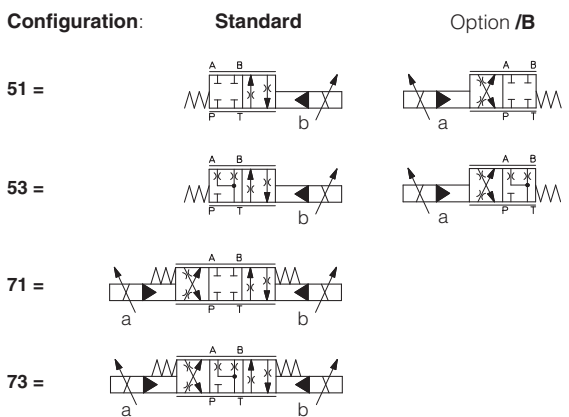

Spool size: 3 (L,S,D) 5 (L,S,D)

DPZA-1 = - 100

DPZA-2 = 160 250

DPZA-4 = - 480

DPZA-6 = - 640

Nominal flow (l/min) at Δp 10bar P-T

Spool type, regulating characteristics:

L = linear

S = progressive

D = differential-progressive



P-A = Q, B-T = Q/2

P-B = Q/2, A-T = Q

(1) The valves with Multicertification for Group II are also certified for Indian market according to **PESO** (Petroleum and Explosives Safety Organization). The PESO certificate can be downloaded from www.atos.com

(2) Not for multicertification **M** group I (mining)

(3) For possible combined options, see 11.1

For valve with internal drain (option /D) the pressure at T port makes difficult the manual override operation that can be possible only if the pressure at T port is lower than 50 bar.

2 ELECTRONIC DRIVERS

Electronic drivers are factory set with max current limitation for ex-proof valves.

Please include in the driver order also the complete code of the connected ex-proof proportional valve.

Drivers model	E-BM-AS-* /A	E-BM-AES-* /A
Type	digital	digital
Format	DIN-rail panel	
Data sheet	G030	GS050

3 GENERAL CHARACTERISTICS

Assembly position	Any position
Subplate surface finishing to ISO 4401	Acceptable roughness index, Ra ≤0,8 recommended Ra 0,4 - flatness ratio 0,01/100
MTTFd valves according to EN ISO 13849	75 years, see technical table P007
Ambient temperature range	Standard = -20°C ÷ +70°C /PE option = -20°C ÷ +70°C /BT option = -40°C ÷ +70°C
Storage temperature range	Standard = -20°C ÷ +80°C /PE option = -20°C ÷ +80°C /BT option = -40°C ÷ +70°C
Surface protection	Zinc coating with black passivation - salt spray test (EN ISO 9227) > 200h
Compliance	Explosion proof protection, see section 7 -Flame proof enclosure "Ex d" -Dust ignition protection by enclosure "Ex t" RoHs Directive 2011/65/EU as last update by 2015/863/EU REACH Regulation (EC) n°1907/2006

4 HYDRAULIC CHARACTERISTICS - based on mineral oil ISO VG 46 at 50 °C

Valve model	DPZA-*-1	DPZA-*-2	DPZA-*-4	DPZA-*-6
Pressure limits [bar]	ports P, A, B, X = 350; T = 250 (10 for option /D); Y = 10;			
Spool type	L5, S5, D5	L3, S3, D3	L5, S5, D5	
Nominal flow [l/min]				
Δp P-T				
Δp = 10 bar	100	160	250	480
Δp = 30 bar	160	270	430	830
Max permissible flow	180	400	550	900
Δp max P-T [bar]				
Piloting pressure [bar]	min. = 25; max = 350 (option /G advisable for pilot pressure > 150 bar)			
Piloting volume [cm³]	1,4	3,7	9,0	21,6
Piloting flow (1) [l/min]	1,7	3,7	6,8	14,4
Leakage (2) Main stage [l/min]	0,15/0,5	0,2/0,6	0,3/1,0	1,0/3,0
Response time (1) [ms]	≤ 90	≤ 110	≤ 130	≤ 190
Hysteresis	≤ 5 [% of max regulation]			
Repeatability	± 1 [% of max regulation]			

Note: above performance data refer to valves coupled with Atos electronic drivers, see section 2

(1) 0-100% step signal and pilot pressure 100 bar (2) at p = 100/350 bar

5 ELECTRICAL CHARACTERISTICS

Max. power	35W	
Insulation class	H (180°) Due to the occurring surface temperatures of the solenoid coils, the European standards ISO 13732-1 and EN982 must be taken into account	
Protection degree with relevant cable gland	Multicertification: IP66/67 to DIN EN60529 UL: raintight enclosure, UL approved	
Duty factor	Continuous rating (ED=100%)	
Voltage code	standard	option /24
Coil resistance R at 20°C	3,2 Ω	17,6 Ω
Max. solenoid current	2,5 A	1,1 A

6 SEALS AND HYDRAULIC FLUIDS - for other fluids not included in below table, consult our technical office

Seals, recommended fluid temperature	NBR seals (standard) = -20°C ÷ +60°C, with HFC hydraulic fluids = -20°C ÷ +50°C FKM seals (/PE option) = -20°C ÷ +80°C HNBR seals (/BT option) = -40°C ÷ +60°C, with HFC hydraulic fluids = -40°C ÷ +50°C		
Recommended viscosity	20 ÷ 100 mm²/s - max allowed range 15 ÷ 300 mm²/s		
Max fluid contamination level	normal operation	ISO4406 class 18/16/13 NAS1638 class 7	see also filter section at
	longer life	ISO4406 class 16/14/11 NAS1638 class 5	www.atos.com or KTF catalog
Hydraulic fluid	Suitable seals type	Classification	Ref. Standard
Mineral oils	NBR, FKM, HNBR	HL, HLP, HLPD, HVLP, HVLPD	DIN 51524
Flame resistant without water	FKM	HFDU, HFDR	ISO 12922
Flame resistant with water (1)	NBR, HNBR	HFC	

⚠ The ignition temperature of the hydraulic fluid must be 50°C higher than the max solenoid surface temperature

(1) **Performance limitations in case of flame resistant fluids with water:**
-max operating pressure = 210 bar -max fluid temperature = 50°C

7 CERTIFICATION DATA

Valve type	DPZA		DPZA/M	DPZA/UL	
Certifications	Multicertification Group II ATEX, IECEX, EAC, PESO, CCC		Multicertification Group I ATEX, IECEX	North American cULus	
Solenoid certified code	OZA-A		OZAM-A	OZA-A/EC	
Type examination certificate (1)	ATEX: CESI 02 ATEX 014 IECEX: IECEX CES 10.0010x EAC: TC RU C-IT. 08.B.01784 PESO: P468212/2 CCC: 2020322307003240		ATEX: CESI 03 ATEX 057x IECEX: IECEX CES 12.0007x	20170324 - E366100	
Method of protection	<ul style="list-style-type: none"> • ATEX, EAC Ex II 2G Ex d IIC T4/T3 Gb Ex II 2D Ex tb IIIC T135°C/T200°C Db • IECEX Ex d IIC T4/T3 Gb Ex tb IIIC T135°C/T200°C Db • PESO Ex db IIC T4/T3 Gb • CCC Ex d IIC T4/T3 Gb Ex tD A21 IP66/IP67 T135°C/T200°C 		<ul style="list-style-type: none"> • ATEX Ex I M2 Ex db I Mb • IECEX Ex db I Mb 	<ul style="list-style-type: none"> • UL 1203 Class I, Div.I, Groups C & D Class I, Zone I, Groups IIA & IIB 	
Temperature class	T4	T3	-	T4	T3
Surface temperature	≤ 135 °C	≤ 200 °C	≤ 150 °C	≤ 135 °C	≤ 200 °C
Ambient temperature (2)	-40 ÷ +40 °C	-40 ÷ +70 °C	-20 ÷ +60 °C	-40 ÷ +55 °C	-40 ÷ +70 °C
Applicable standards	EN 60079-0 EN 60079-1 EN 60079-31		IEC 60079-0 IEC 60079-1 IEC 60079-31	UL 1203 and UL429, CSA 22.2 n°30 CSA 22.2 n°139-13	
Cable entrance: threaded connection vertical (standard) or horizontal (option /O)	GK = GK-1/2" M = M20x1,5 NPT = 1/2" NPT		1/2" NPT		

(1) The type examiner certificates can be downloaded from www.atos.com

(2) The solenoids **Group II** and **cULus** are certified for minimum ambient temperature -40°C

In case the complete valve must withstand with minimum ambient temperature of -40°C, select **/BT** in the model code

⚠ WARNING: service work performed on the valve by the end users or not qualified personnel invalidates the certification

8 EX PROOF SOLENOIDS WIRING

Multicertification

Standard version **Option /O**

① cover with threaded connection for vertical cable gland fitting
 ② cover with threaded connection for horizontal cable gland fitting
 ③ terminal board for cables wiring
 ④ standard manual override
 ⑤ screw terminal for additional equipotential grounding

0 1 = Coil PCB 3 poles terminal board
2 2 = GND suitable for wires cross sections
3 3 = Coil up to 2,5 mm² (max AWG14)

cULus certification

Standard version **Option /O**

① cover with threaded connection for vertical cable gland fitting
 ② cover with threaded connection for horizontal cable gland fitting
 ③ terminal board for cables wiring
 ④ standard manual override

⚠ Pay attention to respect the polarity

0 1 = Coil + PCB 3 poles terminal board sugge-
2 2 = GND sted cable section up to 1,5 mm²
3 3 = Coil - (max AWG16), see section 9 note 1

alternative GND screw terminal connected to solenoid housing

9 CABLE SPECIFICATION AND TEMPERATURE - Power supply and grounding cables have to comply with following characteristics:

Multicertification Group I and Group II	
Power supply: section of coil connection wires = 2,5 mm ²	Grounding: section of internal ground wire = 2,5 mm ² section of external ground wire = 4 mm ²
cULus certification:	
<ul style="list-style-type: none"> • Suitable for use in Class I Division 1, Gas Groups C • Armored Marine Shipboard Cable which meets UL 1309 • Tinned Stranded Copper Conductors • Bronze braided armor • Overall impervious sheath over the armor <p>Any Listed (UBVZ/UBVZ7) Marine Shipboard Cable rated 300 V min, 15A min. 3C 2,5 mm² (14 AWG) having a suitable service temperature range of at least -25°C to +110°C ("BT" Models require a temperature range from -40°C to +110°C)</p> <p>Note 1: For Class I wiring the 3C 1,5 mm² AWG 16 cable size is admitted only if a fuse lower than 10 A is connected to the load side of the solenoid wiring.</p>	

9.1 Cable temperature

The cable must be suitable for the working temperature as specified in the "safety instructions" delivered with the first supply of the products.

Multicertification

Max ambient temperature [°C]	Temperature class		Max surface temperature [°C]		Min. cable temperature [°C]	
	Goup I	Goup II	Goup I	Goup II	Goup I	Goup II
40 °C	-	T4	150 °C	-	90 °C	-
45 °C	-	T4	150 °C	135 °C	-	90 °C
55 °C	-	T3	150 °C	200 °C	-	110 °C
60 °C	-	-	150 °C	-	110 °C	-
70 °C	N.A.	T3	N.A.	200 °C	N.A.	120 °C

cULus certification

Max ambient temperature [°C]	Temperature class	Max surface temperature [°C]	Min. cable temperature
55 °C	T4	135 °C	100 °C
70 °C	T3	200 °C	100 °C

10 CABLE GLANDS - only **Multicertification**

Cable glands with threaded connections GK-1/2", 1/2"NPT or M20x1,5 for standard or armoured cables have to be ordered separately, see tech. table **KX800**

Note: a Loctite sealant type 545, should be used on the cable gland entry threads

11 OPTIONS

B = DPZA-*-*5 = solenoid and integral electronics at side of port B of the main stage.
DPZA-*-*7 = integral electronics at side of port B of the main stage.

D and E = Pilot and drain configuration can be modified as shown in section 13.
The valve's standard configuration provides internal pilot and external drain.
For different pilot / drain configuration select:
Option /D Internal drain.
Option /E External pilot (through port X).

G = Pressure reducing valve installed between pilot valve and main body with fixed setting:
DPZA-1 and -2 = 28 bar
DPZA-4 and -6 = 40 bar
It is advisable for valves with internal pilot in case of system pressure higher than 150 bar.

O = Horizontal cable entrance, to be selected in case of limited vertical space.

WP = Manual override protected by metallic cap.

11.1 Possible combined options

- /BD, /BE, /BG, /BO, /BWP
- /BDE, /BDG, /BDO, /BDWP,
- /BDEG, /BDEO, /BDEWP, /BDEGO, /BDEGWP, BDEGOWP
- /BEG, /BEO, /BEWP, /BEGO, /BEGWP, /BEGOWP
- /BGO, /BGWP, BGOWP
- /DE, /DG, /DO, /DWP, /DEG, /DEO, /DEWP, /DEGO, /DEGWP, /DEGOWP
- /EG, /EO, /EWP, /EGO, /EGWP, /EGOWP
- /GO, /GWP, /GOWP
- /OWP

FUNCTIONAL SCHEME

example of configuration 7*
3 positions, spring centered

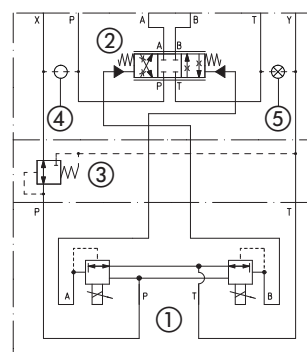

- ① Pilot valve
- ② Main stage
- ③ Pressure reducing valve
- ④ Plug to be added for external pilot trough port X
- ⑤ Plug to be removed for internal drain through port T

12 DIAGRAMS (based on mineral oil ISO VG 46 at 50 °C)

12.1 Regulation diagrams (values measure at Δp 10 bar P-T)

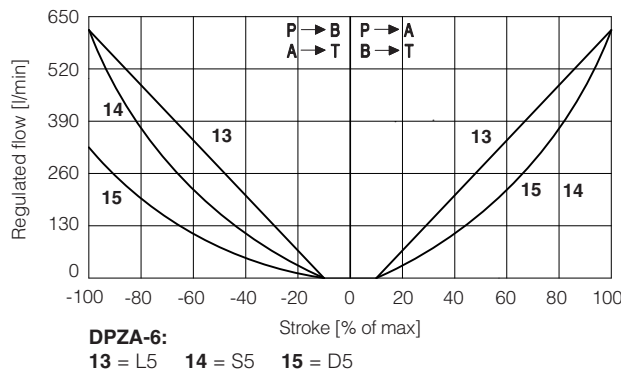
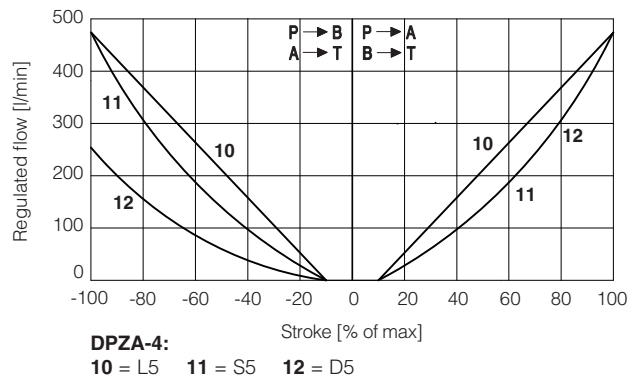
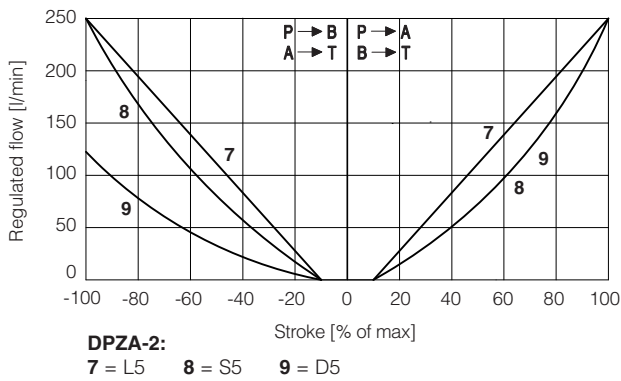
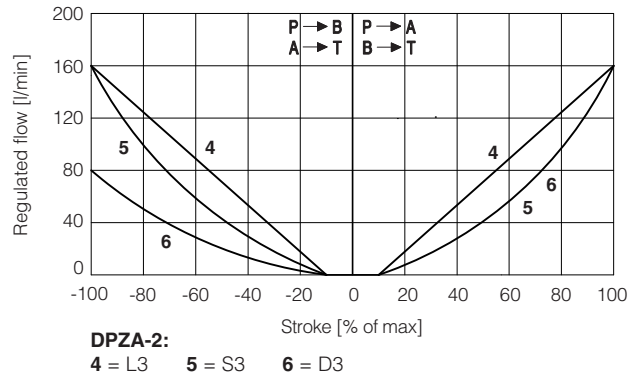
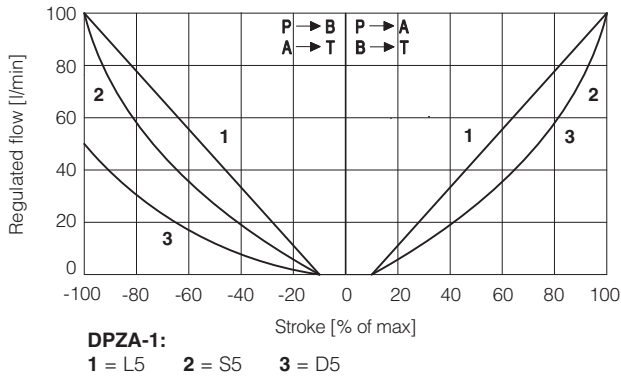

Note: Hydraulic configuration vs. reference signal for configuration 71 and 73 (standard and option /B)

Reference signal $\left. \begin{matrix} 0 \div +10 \text{ V} \\ 12 \div 20 \text{ mA} \end{matrix} \right\} P \rightarrow A / B \rightarrow T$



Reference signal $\left. \begin{matrix} 0 \div -10 \text{ V} \\ 12 \div 4 \text{ mA} \end{matrix} \right\} P \rightarrow B / A \rightarrow T$

13 PLUGS LOCATION FOR PILOT/DRAIN CHANNELS

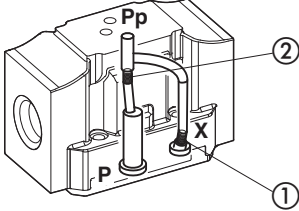
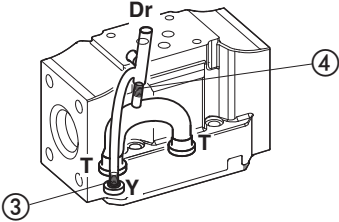
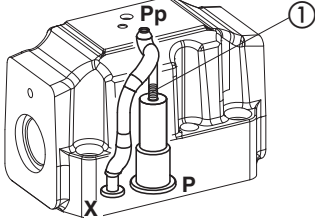
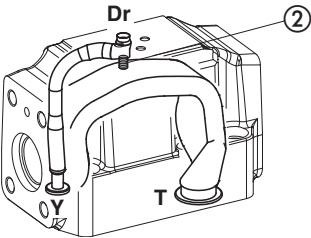
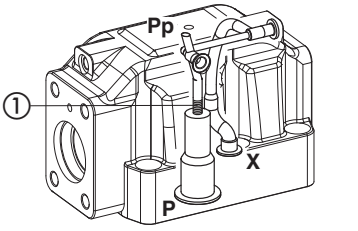
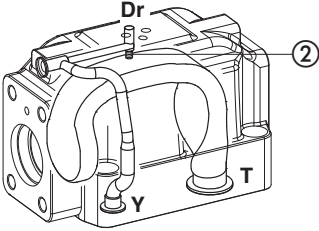
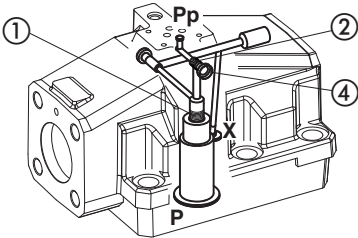
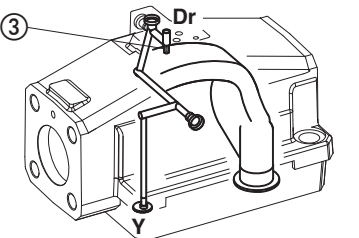
Depending on the position of internal plugs, different pilot/drain configurations can be obtained as shown below.
To modify the pilot/drain configuration, proper plugs must only be interchanged. The plugs have to be sealed using loctite 270.
Standard valves configuration provides internal pilot and external drain

<p>DPZA-1 Pilot channels</p> 	<p>Drain channels</p> 	<p>Internal piloting: blinded plug SP-X300F ① in X; External piloting: blinded plug SP-X300F ② in Pp; Internal drain: blinded plug SP-X300F ③ in Y; External drain: blinded plug SP-X300F ④ in Dr.</p>
<p>DPZA-2 Pilot channels</p> 	<p>Drain channels</p> 	<p>Internal piloting: Without blinded plug SP-X300F ①; External piloting: Add blinded plug SP-X300F ①; Internal drain: Without blinded plug SP-X300F ②; External drain: Add blinded plug SP-X300F ②.</p>
<p>DPZA-4 Pilot channels</p> 	<p>Drain channels</p> 	<p>Internal piloting: Without blinded plug SP-X500F ①; External piloting: Add blinded plug SP-X500F ①; Internal drain: Without blinded plug SP-X300F ②; External drain: Add blinded plug SP-X300F ②.</p>
<p>DPZO-6 Pilot channels</p> 	<p>Drain channels</p> 	<p>Internal piloting: Without plug ①; External piloting: Add DIN-908 M16x1,5 in pos ①; Add plug SP-X325A in pos ②; Internal drain: Without blinded plug SP-X300F ③; External drain: Add blinded plug SP-X300F ③.</p> <p>To reach the orifice ② remove plug ④ = G1/8"</p>

14 FASTENING BOLTS AND SEALS

	DPZA-1	DPZA-2	DPZA-4	DPZA-6
	<p>Fastening bolts: 4 socket head screws M6x60 class 12.9 Tightening torque = 15 Nm</p>	<p>Fastening bolts: 4 socket head screws M10x50 class 12.9 Tightening torque = 70 Nm 2 socket head screws M6x45 class 12.9 Tightening torque = 15 Nm</p>	<p>Fastening bolts: 6 socket head screws M12x60 class 12.9 Tightening torque = 125 Nm</p>	<p>Fastening bolts: 6 socket head screws M20x80 class 12.9 Tightening torque = 600 Nm</p>
	<p>Seals: 5 OR 2050 Diameter of ports A, B, P, T: Ø 11 mm (max) 2 OR 108 Diameter of ports X, Y: Ø 5 mm (max)</p>	<p>Seals: 4 OR 130 Diameter of ports A, B, P, T: Ø 20 mm (max) 2 OR 2043 Diameter of ports X, Y: Ø 7 mm (max)</p>	<p>Seals: 4 OR 4112 Diameter of ports A, B, P, T: Ø 24 mm (max) 2 OR 3056 Diameter of ports X, Y: Ø 7 mm (max)</p>	<p>Seals: 4 OR 144 Diameter of ports A, B, P, T: Ø 34 mm (max) 2 OR 3056 Diameter of ports X, Y: Ø 7 mm (max)</p>

DPZA-1

ISO 4401: 2005 (see table P005)
 Mounting surface: 4401-05-05-0-05

Mass [kg]	
DPZA-*-15*	8,5
DPZA-*-17*	10,2
Option /G	+0,9
Option /O	+0,35
Option /WP	+0,25

DPZA-A-15*
 DPZA-A-17* (dotted line)

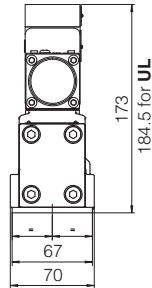
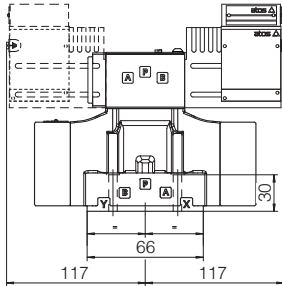

DPZA-A-15* /B

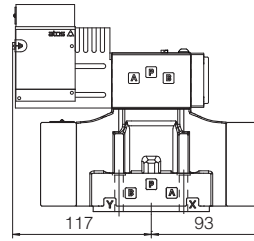

option /O

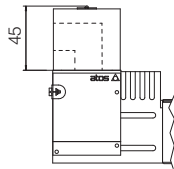

option /WP

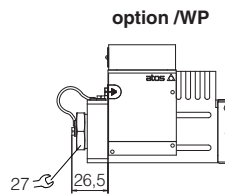

option /G

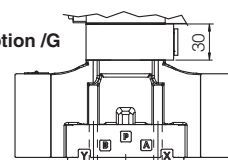

DPZA-2

ISO 4401: 2005 (see table P005)
 Mounting surface: 4401-07-07-0-05

Mass [kg]	
DPZA-*-25*	12,7
DPZA-*-27*	14,4
Option /G	+0,9
Option /O	+0,35
Option /WP	+0,25

DPZA-A-25*
 DPZA-A-27* (dotted line)

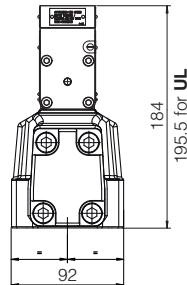
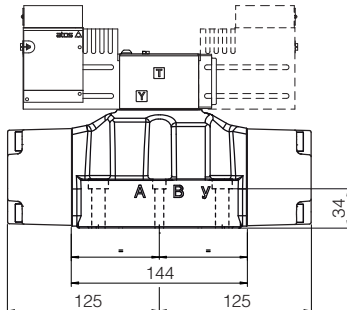

DPZA-A-25* /B

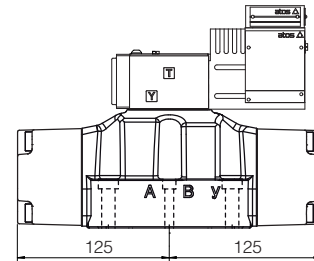

option /O

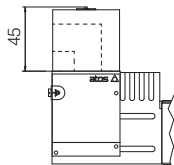

option /WP

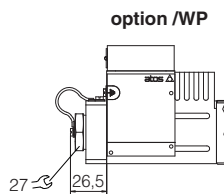

option /G

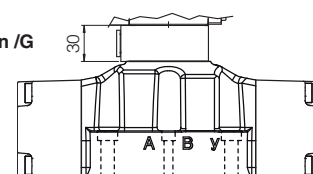

DPZA-4

ISO 4401: 2005 (see table P005)
 Mounting surface: 4401-08-08-0-05

Mass [kg]	
DPZA-*-45*	17,9
DPZA-*-47*	19,6
Option /G	+0,9
Option /O	+0,35
Option /WP	+0,25

DPZA-A-45*
 DPZA-A-47* (dotted line)

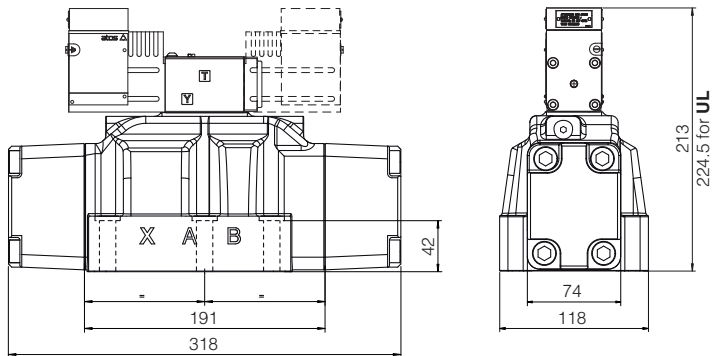

DPZA-A-45* /B

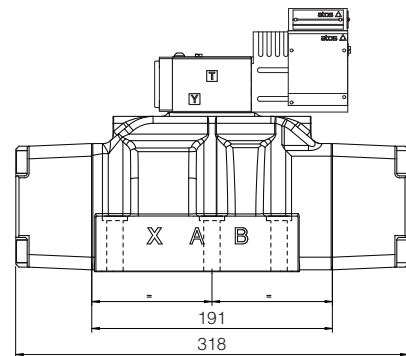

option /O

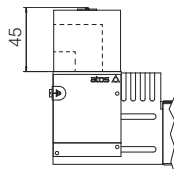

option /WP

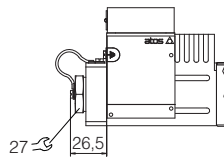

option /G

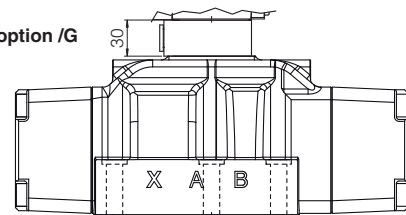

DPZA-6

ISO 4401: 2005 (see table P005)
 Mounting surface: 4401-10-09-0-05

Mass [kg]	
DPZA-*-45*	43,0
DPZA-*-47*	44,7
Option /G	+0,9
Option /O	+0,35
Option /WP	+0,25

DPZA-A-65*
 DPZA-A-67* (dotted line)

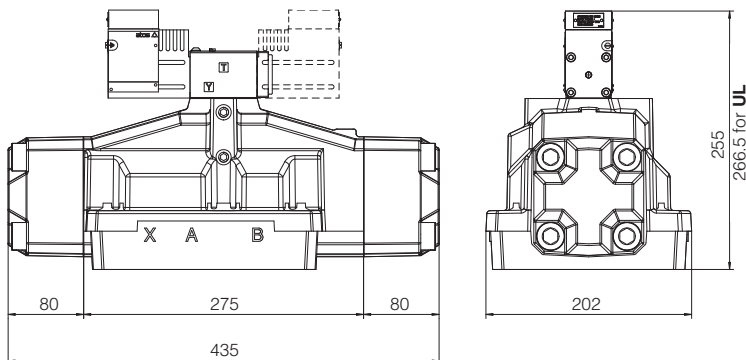

DPZA-A-65* /B

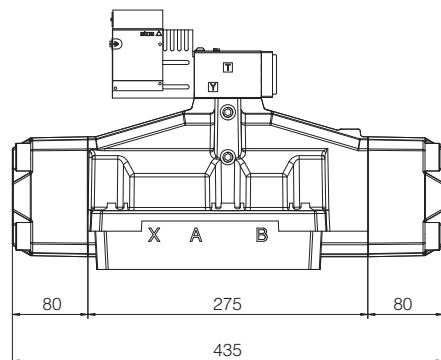

option /O

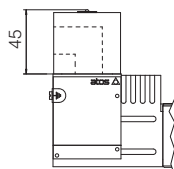

option /WP

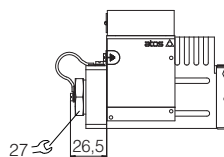

option /G

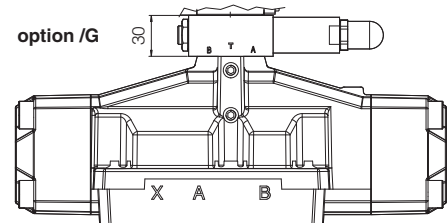

16 RELATED DOCUMENTATION

- X010** Basics for electrohydraulics in hazardous environments
- X020** Summary of Atos ex-proof components certified to ATEX, IECEx, EAC, CCC, PESO
- X030** Summary of Atos ex-proof components certified to cULus
- FX900** Operating and maintenance information for ex-proof proportional valves
- KX800** Cable glands for ex-proof valves
- P005** Mounting surfaces for electrohydraulic valves