

Axial piston pumps type PVC

variable displacement, by a full line of mechanical controls

Available only on request

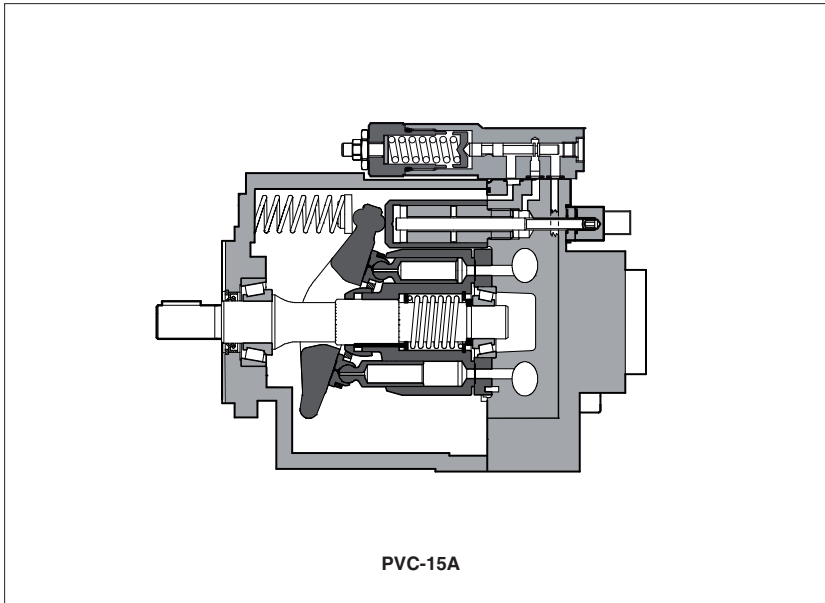

PVC are variable displacement axial piston pumps for medium pressure operation, low noise level, suitable for open circuit systems.

They are available with following hydraulics controls (see section 6):

- A: mechanical pressure compensator with manual adjustment
- GM: compensator with ISO 4401 size 06 mounting surface with P and T connections. This solution allows different type of controls, like multiple pressure selection, venting, etc. which can be realized by installing proper control valves (to be separately ordered), see sections 6 and 9
- HLC: load sensing compensator

Mounting flange with 2 holes and in additional interface with 4 holes
 Max displacement: 23 cm³/rev.
 Max pressure: 210 bar

1 MODEL CODE

PVC	-	*	A	4	R	-	40	-
Variable displacement axial piston pump								- = STD 1012 viton = Viton seals
Displacement: 15 = 15 cm ³ /rev 23 = 23 cm ³ /rev								
Type of control (see section 6): A = manual pressure compensator GM = manual pressure compensator, with mounting surface size 06 for venting or remote pressure control (valve to be ordered separately) HLC = load sensing (pressure & flow)								
Pressure regulation range: 4 = 20 ÷ 210 bar								40 = oil ports with BSPP (Gas) threaded connection
					Direction of rotation (viewed at the shaft end): R = clockwise			

2 OPERATING CHARACTERISTICS

Pump model		PVC-15	PVC-23
Displacement	[cm ³ /rev]	15,0	23,0
Theoretical max flow at 1450 rpm	[l/min]	21,7	33,0
Max working pressure	[bar]	210	
Min inlet pressure	[bar abs.]	0,8	
Max pressure on drain port	[bar abs.]	1,4	
Power consumption at 1450 rpm and at maximum pressure and displacement	[kW]	11	17
Max drain flow	[l/min]	1.5	
Speed rating	[rpm]	500 ÷ 1800	

3 MAIN CHARACTERISTICS

Installation position	Any position. The drain port must be on the top of the pump. Drain line must be separated and unrestricted to the reservoir and extended below the oil level as far from the inlet as possible. Suggested maximum line length is 3 m.
Ambient temperature	from -10°C to +70°C
Fluid	Hydraulic oil as per DIN 51524...535;
Recommended viscosity	15÷100 mm ² /sec at 40°C (ISO VG 15÷100). Maximum start-up viscosity: 800 mm ² /sec
Fluid contamination class	ISO 19/17/14 ISO4406 (class 9 NAS1638)
Fluid temperature	+20°C +60°C (+0°C +80°C with viton seal)

4 INSTALLATION POSITION

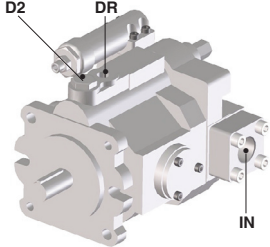
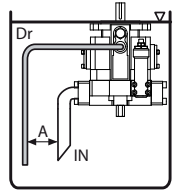
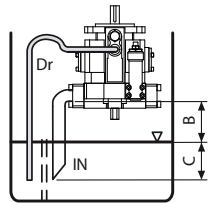
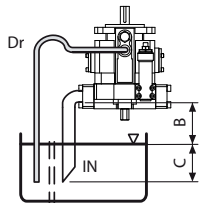
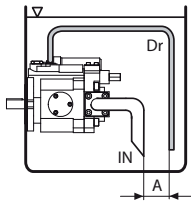
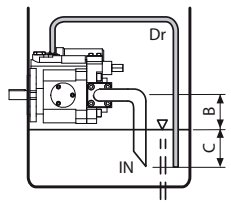
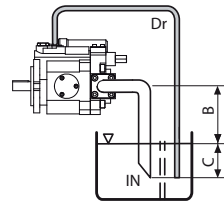
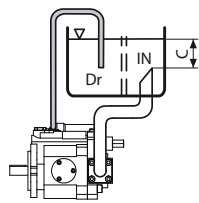
	VERTICAL INSTALLATION		
			
<p>The pump is supplied with drain DR open, and D2 oil filling port plugged. Before installation fill the pump with hydraulic oil through port D2 for at least 3/4 of its volume, keeping it in horizontal position. With exception of pump mounted below the oil level, we recommend to interpose a baffle plate between inlet and drain line.</p>	<p>INSIDE THE TANK</p> <p>Minimum oil level equal or above the pump mounting surface. A ≥ 200mm</p>	<p>INSIDE THE TANK</p> <p>Minimum oil level below the pump mounting surface. Minimum inlet pressure = 0,8 bar absolute B ≤ 800mm, C= 200mm</p>	<p>OUTSIDE THE TANK, above oil level</p> <p>Minimum inlet pressure = 0,8 bar absolute B ≤ 800mm, C= 200mm</p>
HORIZONTAL INSTALLATION			
			
<p>INSIDE THE TANK</p> <p>Minimum oil level equal or above the pump mounting surface. A ≥ 200mm</p>	<p>INSIDE THE TANK</p> <p>Minimum oil level below the pump mounting surface. Minimum inlet pressure = 0,8 bar (absolute) B ≤ 800mm, C= 200mm</p>	<p>OUTSIDE THE TANK, above oil level</p> <p>Minimum inlet pressure = 0,8 bar (absolute) B ≤ 800mm, C= 200mm</p>	<p>OUTSIDE THE TANK, below oil level</p> <p>C= 200mm</p>

IN: inlet line - DR: drain line - A: minimum distance between inlet and drain line - B+C: permissible suction height - C: inlet line immersion depth

5 DIAGRAMS at 1450 rpm (based on mineral oil ISO VG 46 at 50°C)

Noise level curves

Ambient noise levels measured in compliance with ISO 4412-1 oleohydraulics
-Test procedure to define the ambient noise level - Pumps
Shaft speed: 1450 rpm.
— = Qmax = Qmin

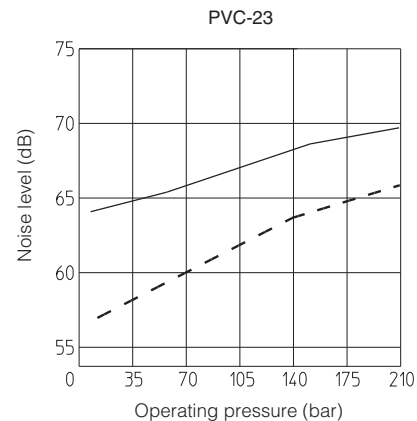
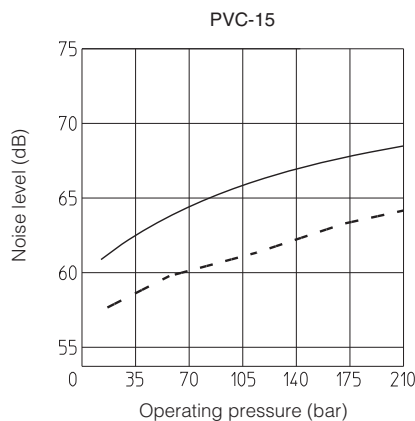

6 HYDRAULIC AND ELECTROHYDRAULIC CONTROLS

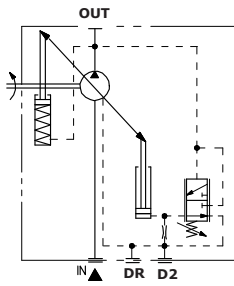

A Manual pressure compensator

The pump displacement decreases when the line pressure approaches the setting pressure of the compensator. The pump supplies only the fluid required by the system. Pressure may be steplessly adjusted at the pilot valve.
 Compensator setting range: 20 ÷ 210 bar
 Compensator standard setting: 140 bar

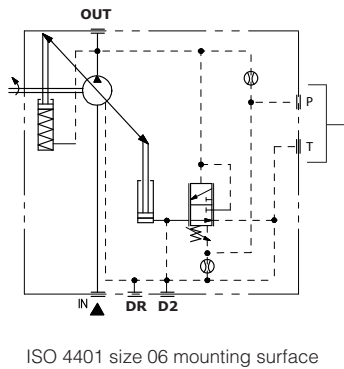
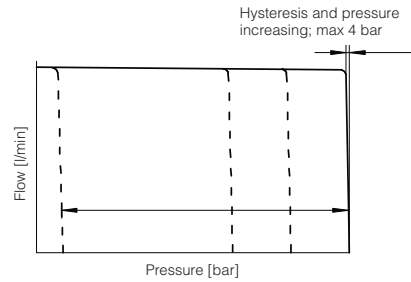

GM General purpose compensator with ISO 4401 size 06 mounting surface

This solution allows different type of controls, like multiple pressure selection, venting, etc. which can be realized by installing proper control valves. The valves must be separately ordered. The pump must be equipped at least with a pressure setting valve.

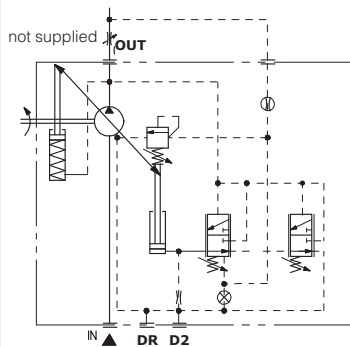
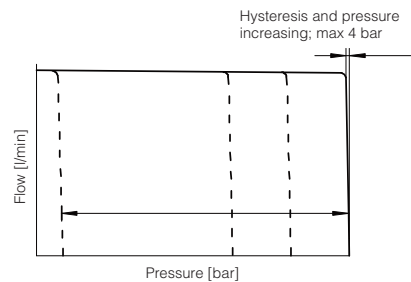

HLC Load sensing

The pump displacement is automatically adjusted to maintain a constant (load independent) pressure drop across an external throttle. Changing the throttle regulation, the pump flow is consequently adjusted. Load sensing control always incorporates an hydraulic compensator to limit the maximum pressure.
 Compensator setting range: 20 ÷ 210 bar
 Compensator standard setting: 140 bar
 Differential pressure setting range: 13 ÷ 27 bar
 Differential pressure standard setting: 21 bar

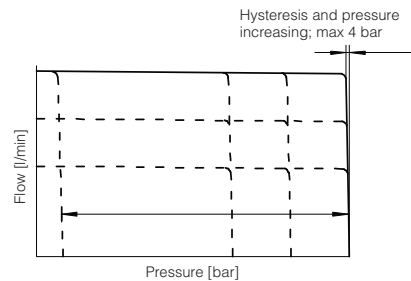

7 SHAFT DIMENSION

PVC-15

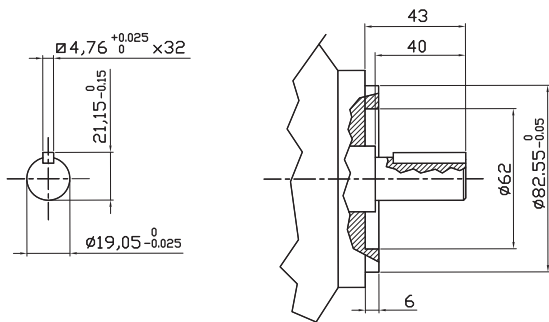

PVC-23

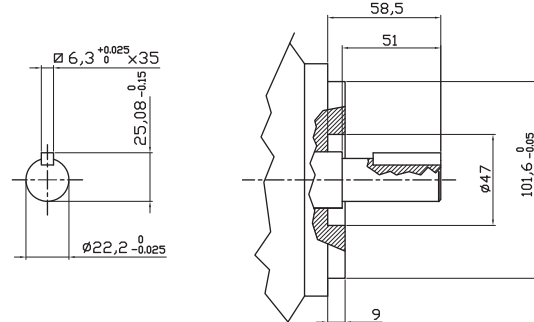

8 DIMENSIONS OF PVC-15A

PORTS DIMENSION

- IN** = 3/4" BSPP
- OUT** = 3/4" BSPP
- DR** = Drain port, 3/8" BSPP
- D2** = Oil filling port, 3/8" BSPP
- ① = Regulation screw for max displacement; clockwise rotation for max displacement reduction
- ② = Regulation screw for max pressure regulation; clockwise rotation for pressure increasing.

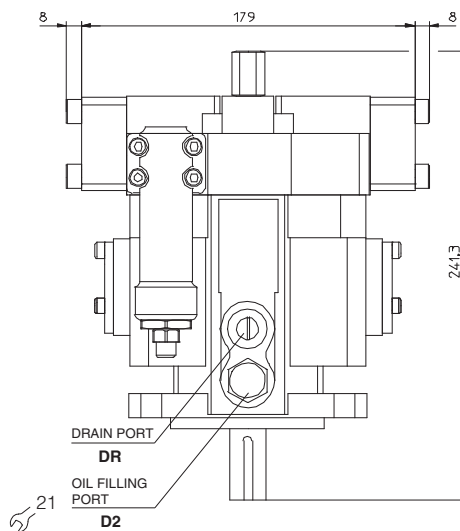
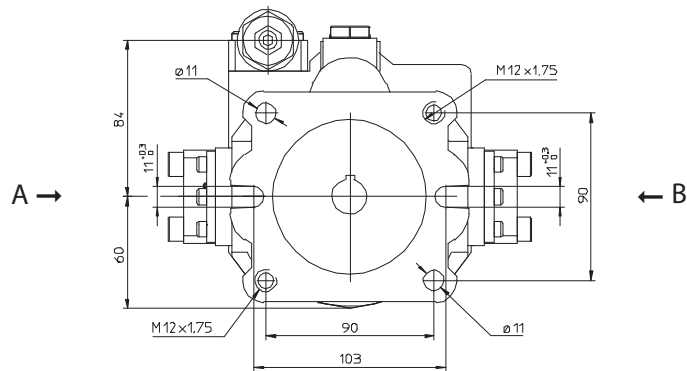
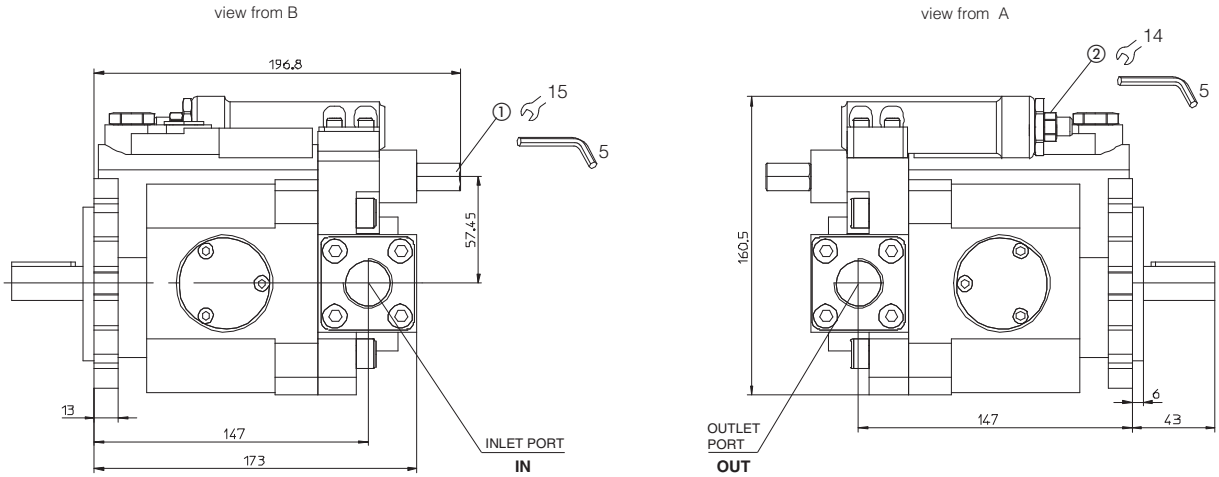

Mass: 13 kg

9 DIMENSIONS OF PVC-15GM

PORTS DIMENSION

- IN** = 3/4" BSPP
- OUT** = 3/4" BSPP
- DR** = Drain port, 3/8" BSPP
- D2** = Oil filling port, 3/8" BSPP
- ① = Regulation screw for max displacement; clockwise rotation for max displacement reduction

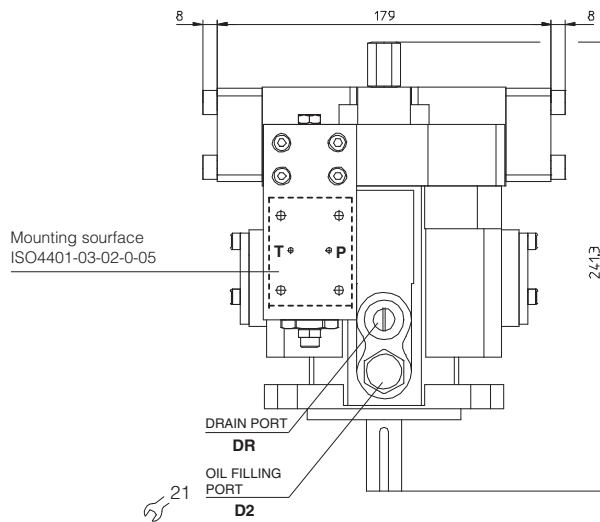
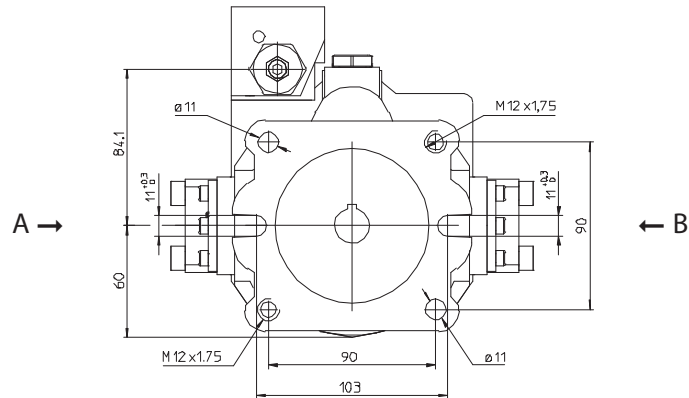
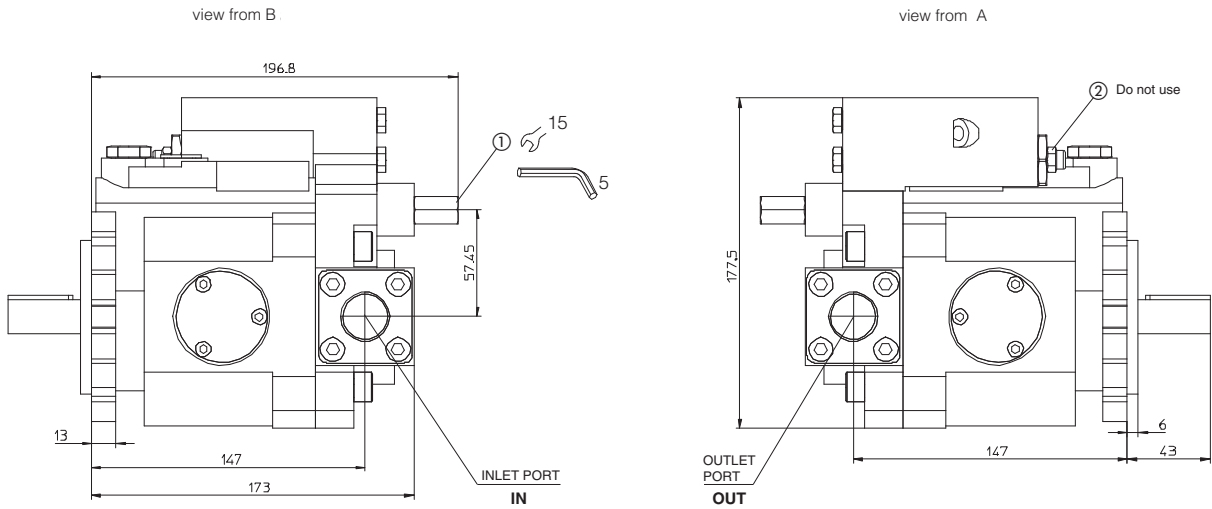

Mass: 13.5 kg

10 DIMENSIONS OF PVC-15HLC

PORTS DIMENSION

- IN** = 3/4" BSPP
- OUT** = 3/4" BSPP
- DR** = Drain port, 3/8" BSPP
- D2** = Oil filling port, 3/8" BSPP
- X** = Load sensing port, 1/4" BSPP
- ① = Regulation screw for max displacement; clockwise rotation for max displacement reduction
- ② = Regulation screw for min. pressure regulation; clockwise rotation for pressure increasing (standard setting 21 bar)
- ③ = Regulation screw for max pressure regulation; clockwise rotation for pressure increasing

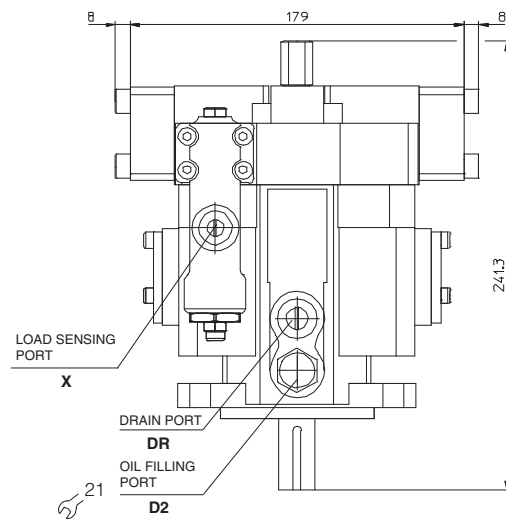
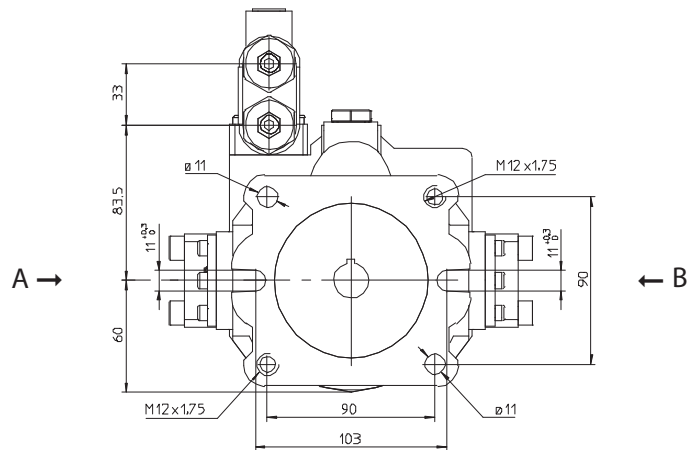
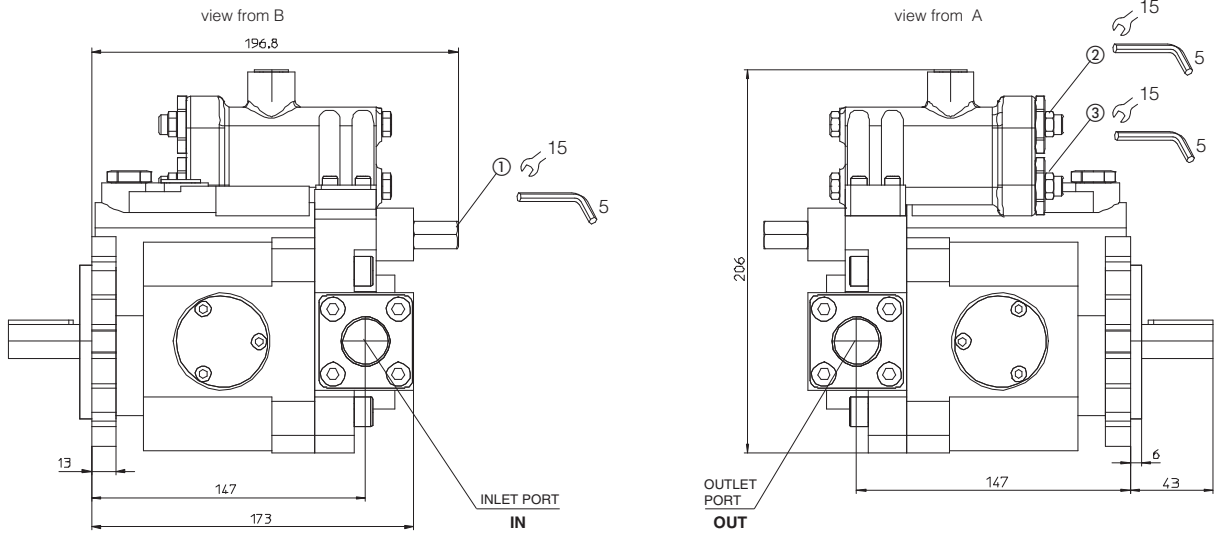

Mass: 13.5 kg

11 DIMENSIONS OF PVC-23A

PORTS DIMENSION

- IN** = 1" BSPP
- OUT** = 3/4" BSPP
- DR** = Drain port, 3/8" BSPP
- D2** = Oil filling port, 3/8" BSPP
- ① = Regulation screw for max displacement; clockwise rotation for max displacement reduction
- ② = Regulation screw for max pressure regulation; clockwise rotation for pressure increasing.

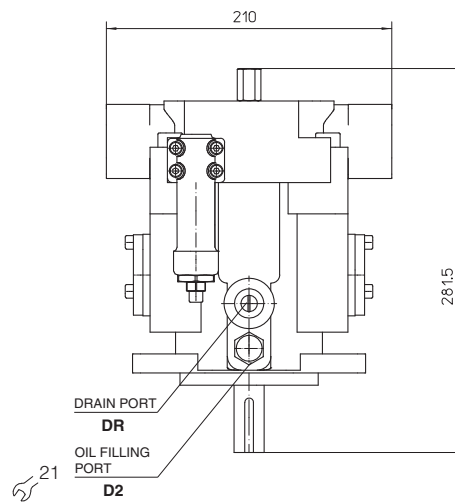
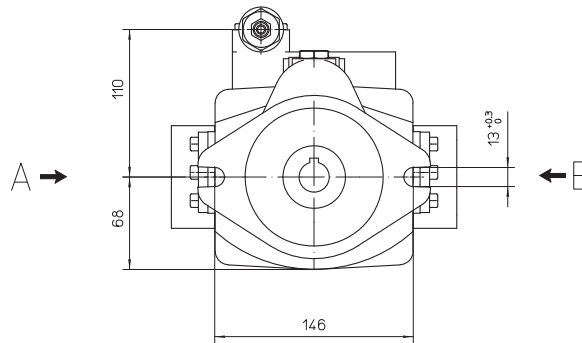
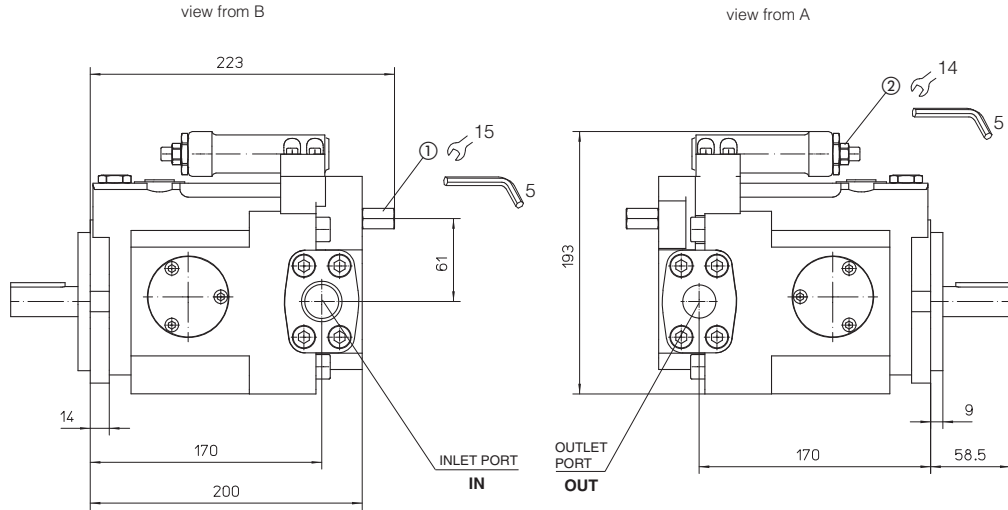

Mass: 22 kg

12 DIMENSIONS OF PVC-23GM

PORTS DIMENSION

- IN** = 1" BSPP
- OUT** = 3/4" BSPP
- DR** = Drain port, 3/8" BSPP
- D2** = Oil filling port, 3/8" BSPP
- ① = Regulation screw for max displacement; clockwise rotation for max displacement reduction

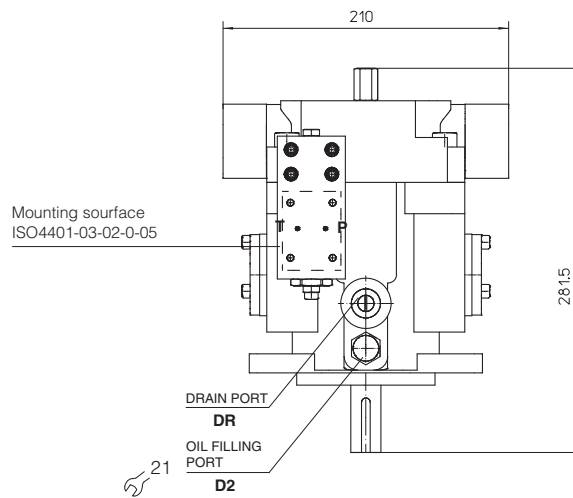
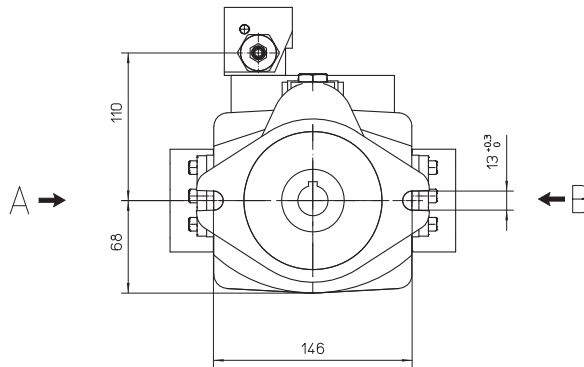
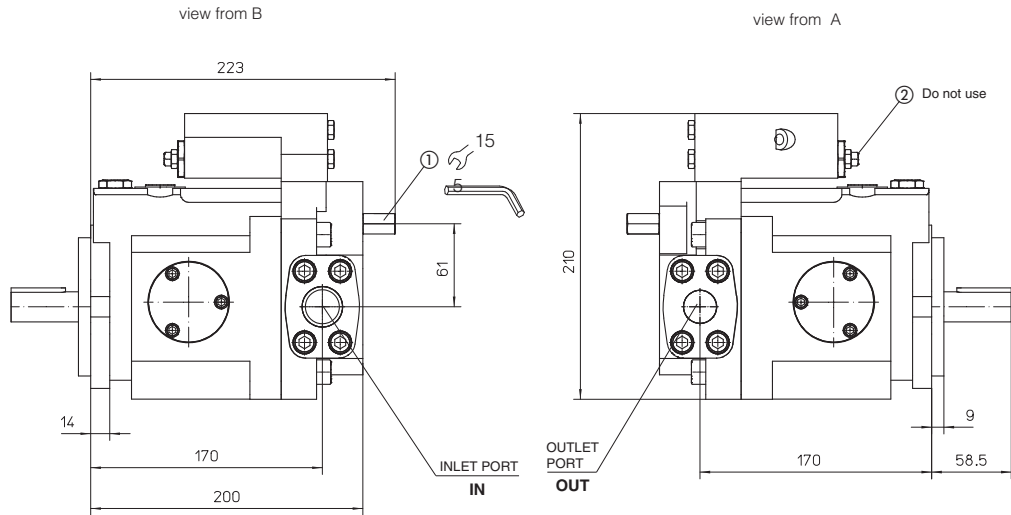

Mass: 22.5 kg

13 DIMENSIONS OF PVC-23HLC

PORTS DIMENSION

- IN** = 1" BSPP
- OUT** = 3/4" BSPP
- DR** = Drain port, 3/8" BSPP
- D2** = Oil filling port, 3/8" BSPP
- X** = Load sensing port, 1/4" BSPP
- ① = Regulation screw for max displacement; clockwise rotation for max displacement reduction
- ② = Regulation screw for min. pressure regulation; clockwise rotation for pressure increasing (standard setting 21 bar)
- ③ = Regulation screw for max pressure regulation; clockwise rotation for pressure increasing

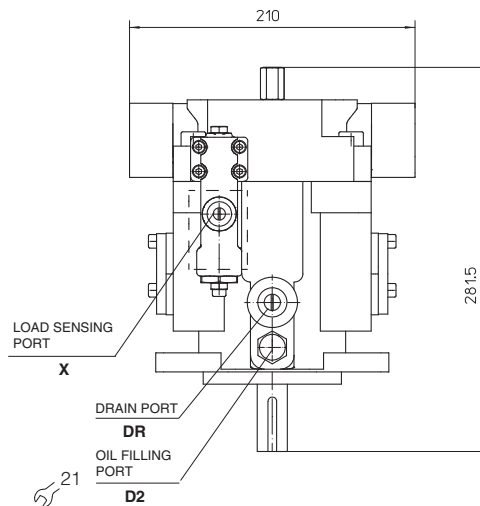
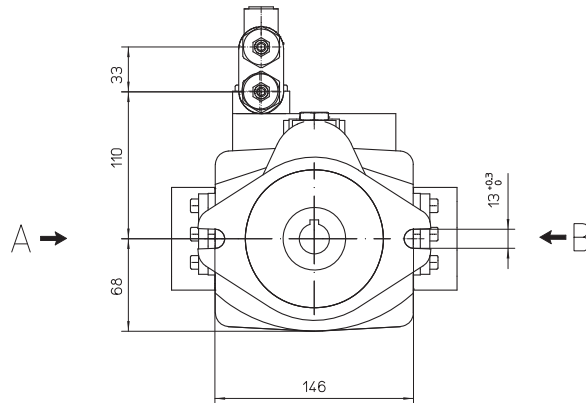
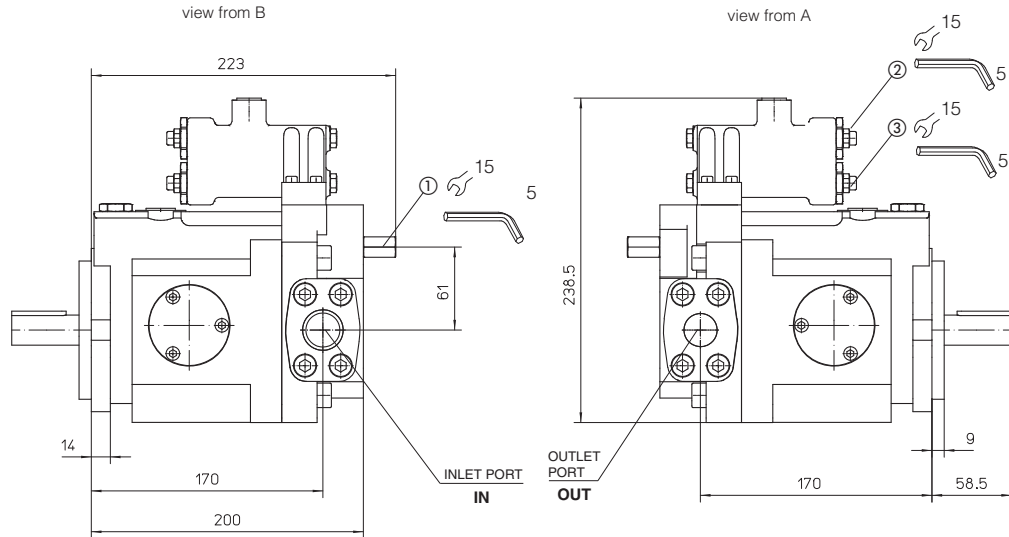

Mass: 22,5 kg