

ISO cartridge valves type SC LIR

directional control, high flow with leak-free poppet

Available only on request

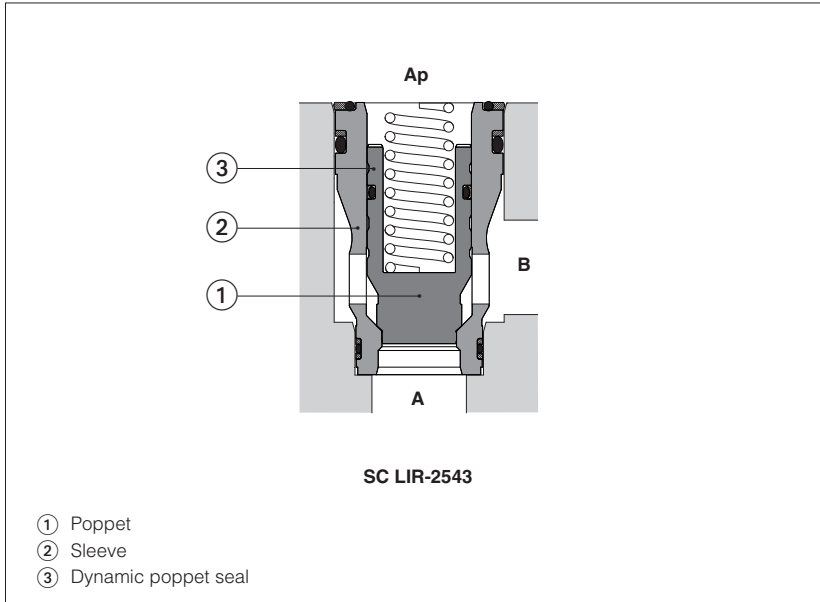

2-way cartridge valves with high flow performances and sealed poppet execution, for applications requiring improved leak-free features as hydraulic circuits with accumulators or with vertical loads.

They can be housed into ISO7368 standard cavity and coupled with Atos functional covers performing directional controls, see tech. tables H030 and H040.

Cartridges are available with different poppet shape, without or with damping nose.

A special dynamic poppet seal avoids internal leakages from port B to Ap (pilot line) side.

Size: **16 to 100** - ISO 7368

Max flow up to **9000** l/min at $\Delta p = 5$ bar

Max pressure up to **420 bar**



1 MODEL CODE

SC LIR	-	16	43	1	/	*
High flow cartridges with leak-free poppet according to ISO 7368						Seals material: - = NBR PE = FKM BT = HNBR
Size, the same of relevant cover: 16 25 32 40 50 63 80 100						
Type of poppet 32, 33 (size 16 to 100) = without damping nose 42 (size 16 to 80) = as 32 but with damping nose 43 (size 16 to 100) = as 33 but with damping nose						
Series number						
Spring cracking pressure: 1 = 0,3 bar for poppet 32, 42 2 = 1,5 bar for poppet 32, 42 1 = 0,6 bar for poppet 33, 43 3 = 3 bar for all poppets 6 = 5,5 bar for all poppets						

Note: new SC LIR are mechanically interchangeable with old SHLIR types

They can be coupled with Atos functional covers performing directional controls, see tech. tables H030 and H040

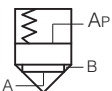
2 HYDRAULIC SYMBOL

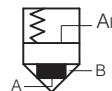
Type of poppet			
32	33	42	43
			

3 HYDRAULIC CHARACTERISTICS - based on mineral oil ISO VG 46 at 50 °C

Type of poppet		32	33	42	43
Operating pressure		420 bar max			
Nominal flow at Δp 5bar (l/min) see diagrams Q/ Δp at section [5]	Size 16	270	270	240	240
	25	550	550	500	500
	32	1000	1000	800	800
	40	1700	1700	1400	1400
	50	2500	2500	2200	2200
	63	4000	4000	3300	3300
	80	5500	5500	4000	4000
	100	9000	9000	-	6300
Typical section					
Area ratio A:Ap		1:1,1	1:1,5	1:1,1	1:1,5
Cracking pressure A→B	Spring 1	0,3 bar	0,6 bar	0,3 bar	0,6 bar
	2	1,5 bar	-	1,5 bar	-
	3	3 bar	3 bar	3 bar	3 bar
	6	5,5 bar	5,5 bar	5,5 bar	5,5 bar
Cracking pressure B→A	Spring 1	3 bar	1,2 bar	3 bar	1,2 bar
	2	12,8 bar	-	12,8 bar	-
	3	32,5 bar	6 bar	32,5 bar	6 bar
	6	54,5 bar	11 bar	54,5 bar	11 bar

4 MAIN CHARACTERISTICS, SEALS AND HYDRAULIC FLUIDS - for other fluids not included in below table, consult our technical office

Assembly position / location	Any position		
Subplate surface finishing	Roughness index Ra 0,4 - flatness ratio 0,01/100 (ISO 1101)		
MTTFd values according to EN ISO 13849	150 years, for further details see technical table P007		
Compliance	RoHS Directive 2011/65/EU as last update by 2015/65/EU REACH Regulation (EC) n°1907/2006		
Ambient temperature	Standard execution = -30°C ÷ +70°C /PE option = -20°C ÷ +70°C /BT option = -40°C ÷ +70°C		
Seals, recommended fluid temperature	NBR seals (standard) = -20°C ÷ +80°C, with HFC hydraulic fluids = -20°C ÷ +50°C FKM seals (/PE option) = -20°C ÷ +80°C HNBR seals (/BT option) = -40°C ÷ +60°C, with HFC hydraulic fluids = -40°C ÷ +50°C		
Recommended viscosity	15 ÷ 100 mm ² /s - max allowed range 2.8 ÷ 500 mm ² /s		
Max fluid contamination level	ISO4406 class 20/18/15 NAS1638 class 9, see also filter section at www.atos.com or KTF catalog)		
Hydraulic fluid	Suitable seals type	Classification	Ref. Standard
Mineral oils	NBR, FKM, HNBR	HL, HLP, HLPD, HVLP, HVLPD	DIN 51524
Flame resistant without water	FKM	HFDU, HFDR	ISO 12922
Flame resistant with water	NBR, HNBR	HFC	
Flow direction	From A→B or B→A		

5 Q/Δp DIAGRAMS based on mineral oil ISO VG 46 at 50 °C

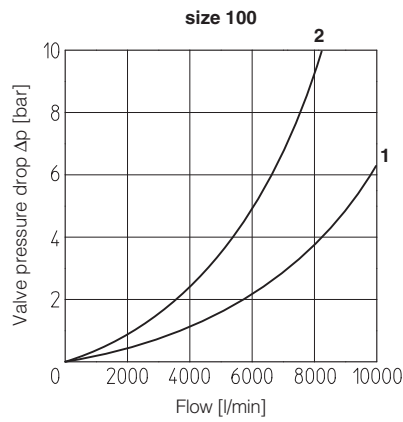
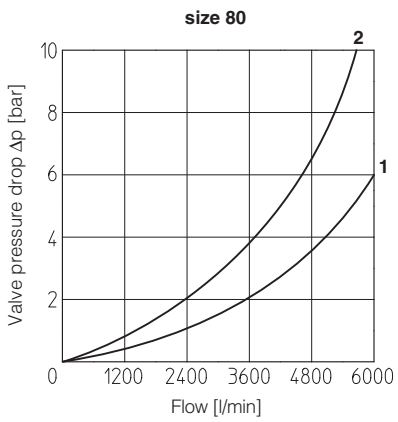
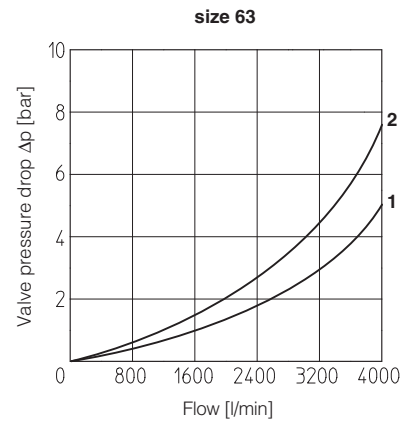
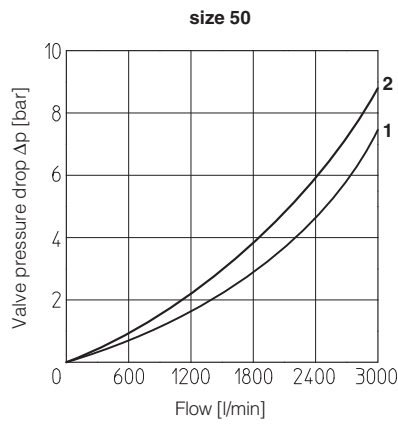
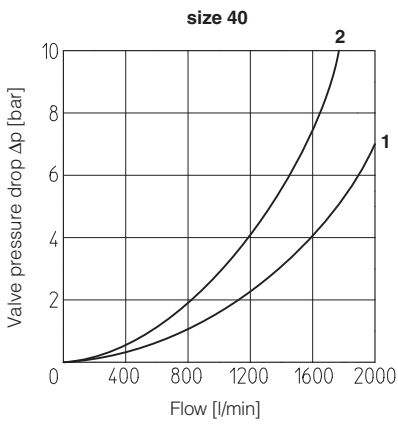
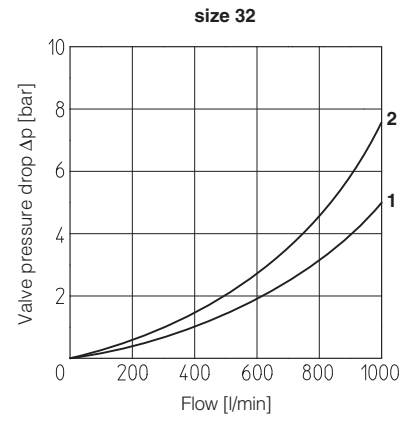
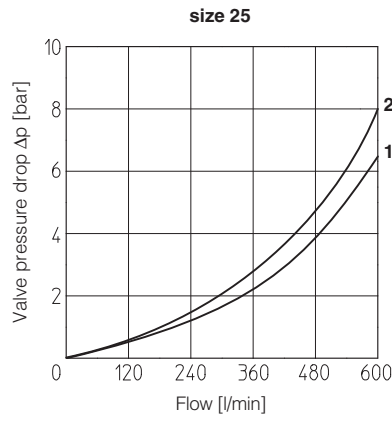
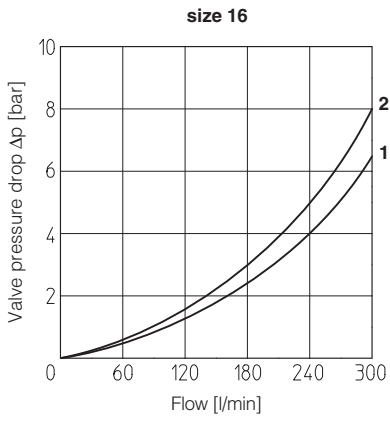

1 = poppet type 32 and 33
2 = poppet type 42 and 43

6 INSTALLATION - for cavity dimensions, see table P006

