

Intrinsically safe ISO cartridge valves

on-off directional control - **ATEX, IECEx, EAC**

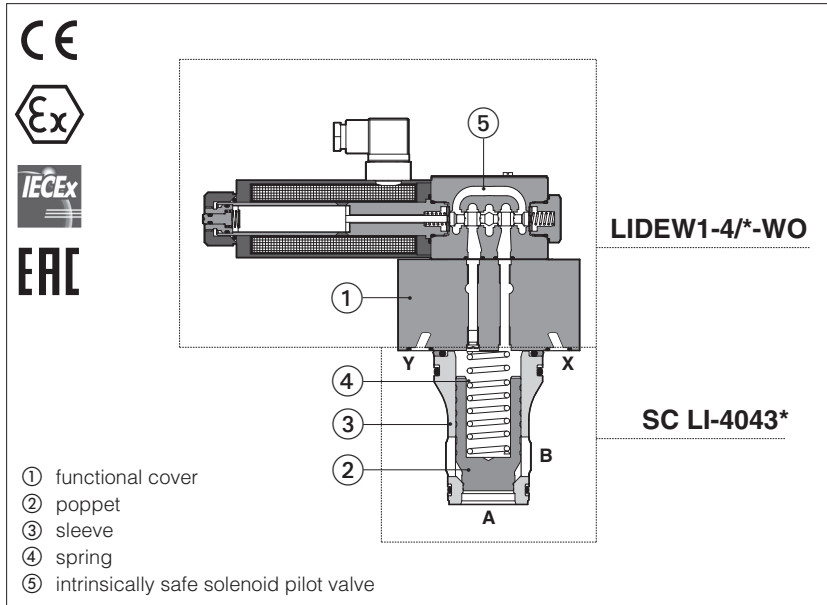

LIDEW, LIDBH, SC LI

On-off ISO directional cartridges equipped with intrinsically safe solenoid pilot valve for poppet control, certified for safe operation in hazardous environment with potentially explosive atmosphere.

Certifications:

- Multicertification **ATEX, IECEx, EAC:** for gas group **II 1G** surface plants zone 0, 1, 2
- Multicertification **ATEX and IECEx:** **I M1** tunnels or mining plants

See section [11] for certification data

The valves must be electrically powered through specific "safety barriers" limiting the max current to the solenoid, see section [13]

LIDEW: directional control with ex-proof solenoid valve for poppet control

LIDBH: directional control with solenoid valve and shuttle valve for pilot line selection

Size: **16 ÷ 63** - ISO 7368

Flow: **240 ÷ 4000 l/min** at Δp 5 bar

Max pressure: **350 bar**

1 MODEL CODE OF COVERS - to be coupled with cartridge in section 5

LI	D	EW / *	-	1	-	1	/	*	-	WO	/	*	/	*
Cover according to ISO 7368	D = directional function	EW = with pilot solenoid valve BH = as EW plus shuttle valve for pilot selection												Optional different setting of the calibrated plugs in the pilot channels, see section [3]
Certification type: - = Omit for Group II 1G M = Group I (mining)														
Cover configuration see section [2]: LIDEW: -, 1, 2, 4, 5, 6 LIDBH: 1A, 1C, 2A, 2C														
Valve size (ISO 7368): 1 = 16 3 = 32 5 = 50 2 = 25 4 = 40 6 = 63														
Options (2): B = cartridge piloted via port "B" of solenoid pilot valve E = external attachments X (1/4" GAS) and underneath port X supplied plugged (only for sizes 40...63) WP =  prolonged manual override protected by rubber cap														
Series number														
WO = Intrinsically safe pilot solenoid valve														
Seals material, see section [10]: - = NBR PE = FKM BT = HNBR (1)														

(1) Not for certification **M** Group I (mining)

(2) Possible combined options: all combinations are available

 The pressure at T port makes difficult the manual override operation that can be possible only if its value is lower than 50 bar

2 VALVES CONFIGURATIONS AND HYDRAULIC SYMBOLS

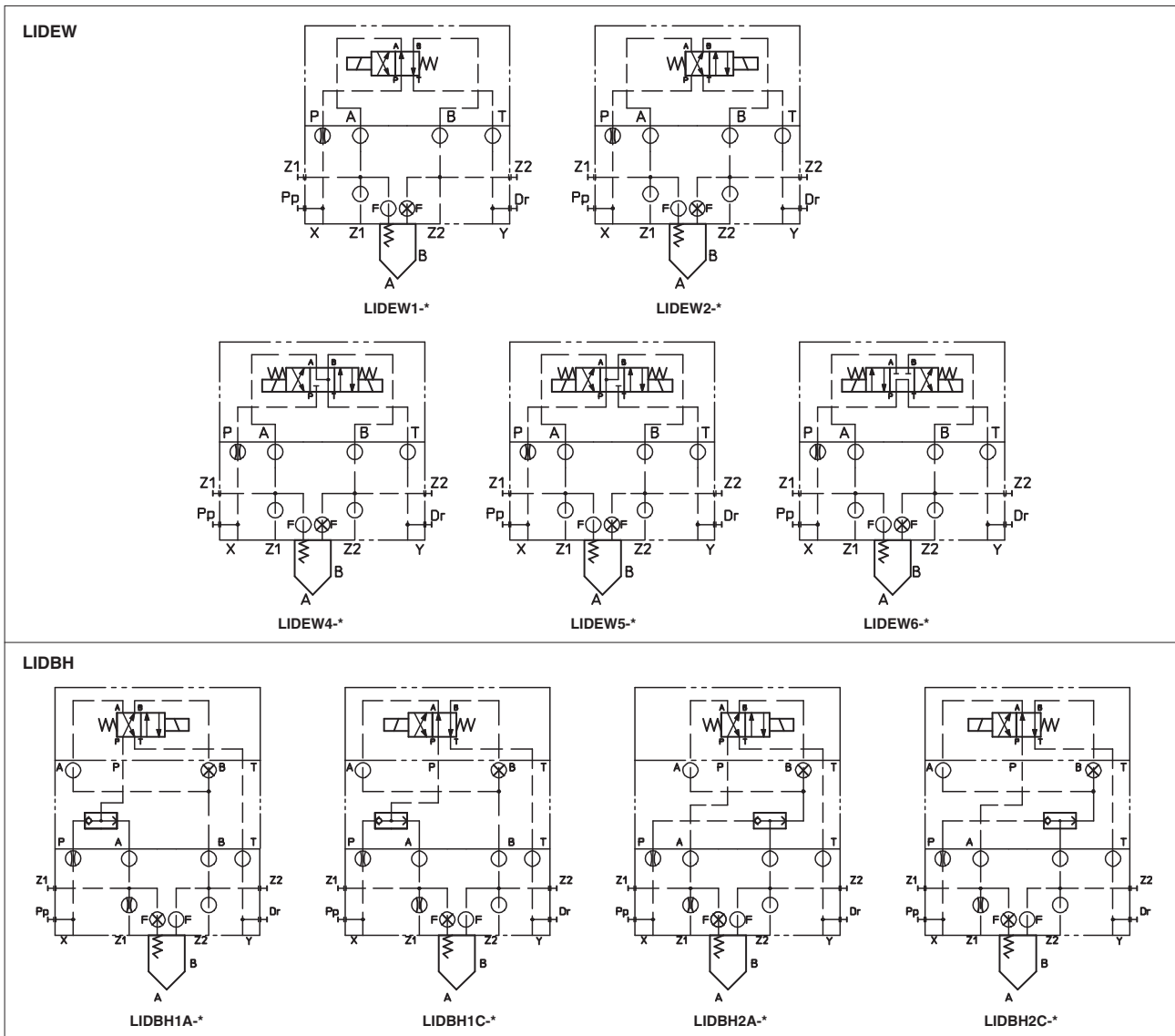

3 OPTIONS

For LIDEW*, LIDBH* covers (sizes 40...100):

/E = with external attachments Pp and underneath port X supplied plugged;

For all the models:

/B = cartridge piloted via port "B" of solenoid pilot valve;

/F = prearranged for coupling to an intermediate element with poppet position detector for safety function. See tab. EY120.

/WP = prolonged manual override protected by rubber cap, for solenoid pilot valve.

******* = Calibrated plugs different from standard ones reported in section 4. The restrictors configuration (if different from the standard) must be indicated at the end of the model code:

LIDEW2	- 1	/*	- WO	/6	**	P	06
						Channel where the orifice has to be provided: P = channel X, port P Z1 = channel Z1 F = channel F Z2 = channel Z2	Size of the throttling hole in tenths of millimeters: 05 = 0,5 mm 10 = 1 mm 17 = 1,7 mm 06 = 0,6 mm 12 = 1,2 mm 20 = 2 mm 08 = 0,8 mm 15 = 1,5 mm

4 STANDARD ORIFICES CONFIGURATION

Cover \ Port	LIDEW*-1 LIDBH*-1	LIDEW*-2 LIDBH*-2	LIDEW*-3 LIDBH*-3	LIDEW*-4 LIDBH*-4	LIDEW*-5 LIDBH*-5	LIDEW*-6 LIDBH*-6
Z1 (only for LIDBH*-*)	M4 12A	M4 12A	M6 15A	M6 17A	M6 20A	M6 20A
P	M6 12A	M6 12A	M6 15A	M6 17A	M6 20A	M6 20A

M4 ÷ M8 = screw size; **12A ÷ 20A** = calibrated orifices diameter in tenths of mm; **A** = short calibrated hole

5 MODEL CODE OF SLIP-IN CARTRIDGES, to be coupled with covers in section **1**

SC LI	-	16	43	1	40	I*
Cartridge valve						Seals material: - = NBR PE = FKM BT = HNBR
Size (ISO 7368): 16 25 32 40 50 63						
Type of poppet, see section 6 for maximum flow 32, 33 42 = as 32 but with dumping nose 43 = as 33 but with dumping nose						
High flow: 40 = all sizes						
Spring cracking pressure: 1 = 0,3 bar for poppet 32, 42; 1 = 0,6 bar for poppet 33, 43; 2 = 1,5 bar for poppet 32, 42; 3 = 3 bar for all poppets 6 = 5,5 bar for all poppets						

6 TYPE OF POPPET

Type of poppet	32						33						42						43					
Functional sketch (Hydraulic symbol)																								
Operating pressure	420 bar max (only SCLI cartridge)																							
Nominal flow at Δp 5bar (l/min) see diagrams Q/Δp at section 9	Size 16 : 270						270						240						240					
	Size 25 : 550						550						500						500					
	Size 32 : 1000						1000						800						800					
	Size 40 : 1700						1700						1400						1400					
	Size 50 : 2500						2500						2200						2200					
	Size 63 : 4000						4000						3300						3300					
Typical section																								
Area ratio A:Ap	1:1,1						1:1,5						1:1,1						1:1,5					
Cracking pressure A→B (bar)	Spring 1 : 0,3						0,6						0,4						0,7					
	Spring 2 : 1,5						-						1,7						-					
	Spring 3 : 3						3						3,3 3,6 3,4						3,3 3,6 3,3					
	Spring 6 : 5,3 5,0 4,3						5,1 5,5 4,8 5,8						6,1 6,4 5,2 4,7						5,8 6,3 7,3 5,7 6,5					
Cracking pressure B→A (bar)	Spring 1 : 3						1,2						3						1,2					
	Spring 2 : 12,8						-						12,8						-					
	Spring 3 : 32,5						6						6,5 7 7,5						6,5 7 7,5					
	Spring 6 : 54 56 48						10 11 12,5						62,5 72 58 47						11,4 12,6 14,5 13 14					

7 GENERAL CHARACTERISTICS

Assembly position / location	Horizontal position only
Subplate surface finishing to ISO 4401	Acceptable roughness index, Ra ≤0,8 recommended Ra 0,4 - flatness ratio 0,01/100
MTTFd values according to EN ISO 13849	75 years, for further details see technical table P007
Ambient temperature	Standard = -20°C ÷ +60°C / PE option = -20°C ÷ +60°C / BT option = -40°C ÷ +60°C
Storage temperature range	Standard = -20°C ÷ +70°C / PE option = -20°C ÷ +70°C / BT option = -40°C ÷ +70°C
Surface protection	Zinc coating with black passivation - salt spray test (EN ISO 9227) > 200h
Compliance	Intrinsically safe protection "Ex ia", see section 11 RoHs Directive 2011/65/EU as last update by 2015/863/EU REACH Regulation (EC) n°1907/2006

8 HYDRAULIC CHARACTERISTICS

Functional cover operating pressure	port A, B, X, Z1, Z2 = 350 ; port Y = 160
Rated flow	see section 6

9 ELECTRICAL CHARACTERISTICS - see also section **11**

Nominal resistance at 20°C	157 Ω
Coil insulation	Class H
Minimum supply current	70 mA
Protection degree	IP65; IP66/IP67 with mating connector suitable for the protection class
Duty factor	100%
Electrical connector	DIN 43650 2 pin+GND

10 SEALS AND HYDRAULIC FLUIDS - for other fluids not included in below table, consult our technical office

Seals, recommended fluid temperature	NBR seals (standard) = -20°C ÷ +60°C, with HFC hydraulic fluids = -20°C ÷ +50°C FKM seals (/PE option) = -20°C ÷ +80°C HNBR seals (/BT option) = -40°C ÷ +60°C, with HFC hydraulic fluids = -40°C ÷ +50°C		
Recommended viscosity	15 ÷ 100 mm ² /s - max allowed range 2.8 ÷ 500 mm ² /s		
Max fluid contamination level	ISO4406 class 20/18/15 NAS1638 class 9, see also filter section at www.atos.com or KTF catalog		
Hydraulic fluid	Suitable seals type	Classification	Ref. Standard
Mineral oils	NBR, FKM, HNBR	HL, HLP, HLPD, HVLP, HVLPD	DIN 51524
Flame resistant without water	FKM	HFDU, HFDR	ISO 12922
Flame resistant with water	NBR, HNBR	HFC	

⚠ The ignition temperature of the hydraulic fluid must be 50°C higher than the max solenoid surface temperature

(1) Performance limitations in case of flame resistant fluids with water:

- max operating pressure = 210 bar
- max fluid temperature = 50°C

11 CERTIFICATION DATA

Valve type	LIDEW, LIDBH			LIDEW/M, LIDBH/M
Certification	ATEX, IECEx (Group II), EAC			ATEX, IECEx (Group I)
Solenoid code	COW-150			COW-150/M
Type examination certificate (1)	ATEX: TUV IT 22 ATEX 051X; IECEX: IECEX TPS 22.0057X;		EAC:RU C - IT.AX38.B.00425/21	ATEX: TUV IT 22 ATEX 051X IECEX: IECEX TPS 22.0057x
Method of protection	<ul style="list-style-type: none"> • ATEX, Ex II 1G Ex ia IIC T6 Ga Ex II 1G Ex ia IIC T5 Ga • IECEX Ex ia IIC T6 Ga Ex ia IIC T5 Ga 	<ul style="list-style-type: none"> • EAC 1Ex ia IIC T6/T5 Ga X 	<ul style="list-style-type: none"> • ATEX, Ex I M1 Ex ia I Ma • IECEX Ex ia I Ma 	
Temperature class	T6		T5	-
Electrical characteristics (max values)	Ci , Li	≅ 0	≅ 0	≅ 0
	Ui [V]	30V	30V	30V
	Ii [mA]	800mA	2200mA	2200mA
	Pi [W]	3W	6.82W	6.82W
Ambient temperature	Standard: -40 ÷ +60°C /BT option: -40 ÷ +60°C	Standard: -40 ÷ +45°C /BT option: -40 ÷ +45°C	Standard: -40 ÷ +60°C /BT option: -40 ÷ +60°C	Standard: -40 ÷ +60°C /BT option: -40 ÷ +60°C
Applicable standards	EN 60079-0 EN 60079-11		IEC 60079-0 IEC 60079-11	

(1) The type examiner certificates can be downloaded from www.atos.com

⚠ WARNING: service work performed on the valve by the end users or not qualified personnel invalidates the certification

12 EX PROOF SOLENOIDS WIRING

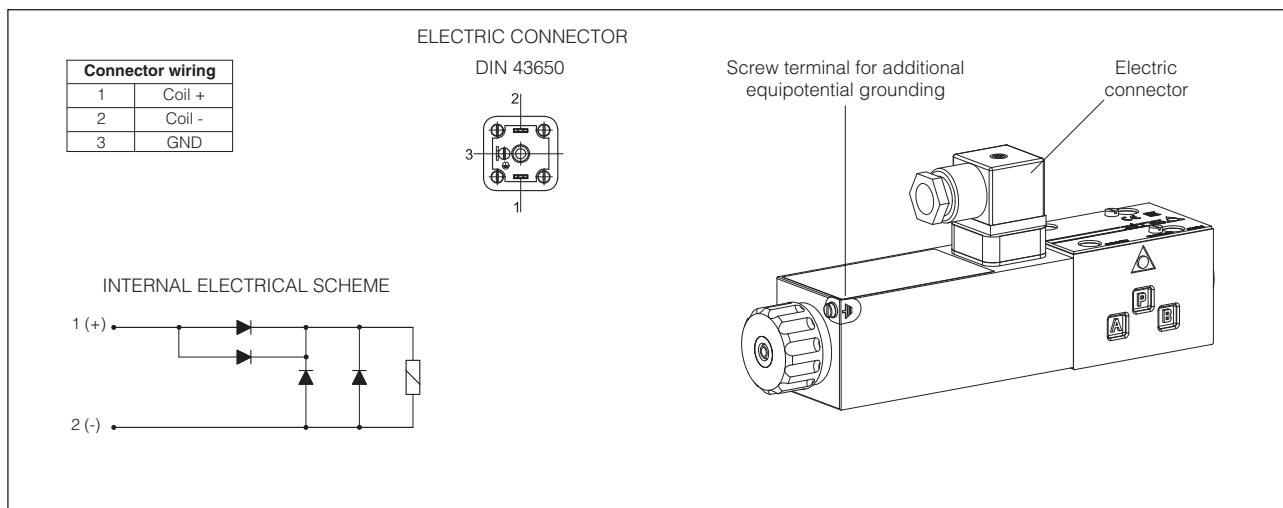

13 **INTRINSICALLY SAFE BARRIERS** - see tech. table **GX010**

Intrinsically safe valves must be powered through safety barriers certified according to Ex-i protection mode, limiting the energy to the solenoid.

To select the proper intrinsically safe barriers following data must be considered:

- 1) V_{max} and I_{max} of the solenoid as specified in section **11** must not be exceeded also in fault conditions;
- 2) For proper operation, the minimum supply current value must be provided (such as 90mA for coil 108 Ω , with Y-BXNE 412).

The barriers type **Y-BXNE 412** are galvanically isolated electronic devices, complying with European Norms EN60079-0/06, EN60079-11/07 and ATEX certified according to protection mode Ex ia IIC.

The barriers Y-BXNE-412 are double channel type, suitable to operate valves with double or single solenoid. Two single solenoid valves can be connected to the barrier (one to each channel) but they cannot be contemporary operated.

MODEL CODE OF I.S. BARRIER

Y-BXNE 412 00	*
Supply voltage	
E = 110/230 V _{AC}	
2 = 24÷48 V _{DC}	

14 **Q/Δp DIAGRAMS** based on mineral oil ISO VG 46 at 50 °C

SC LI High flow - series 40

1 = poppet type 32 and 33 **2** = poppet type 42 and 43

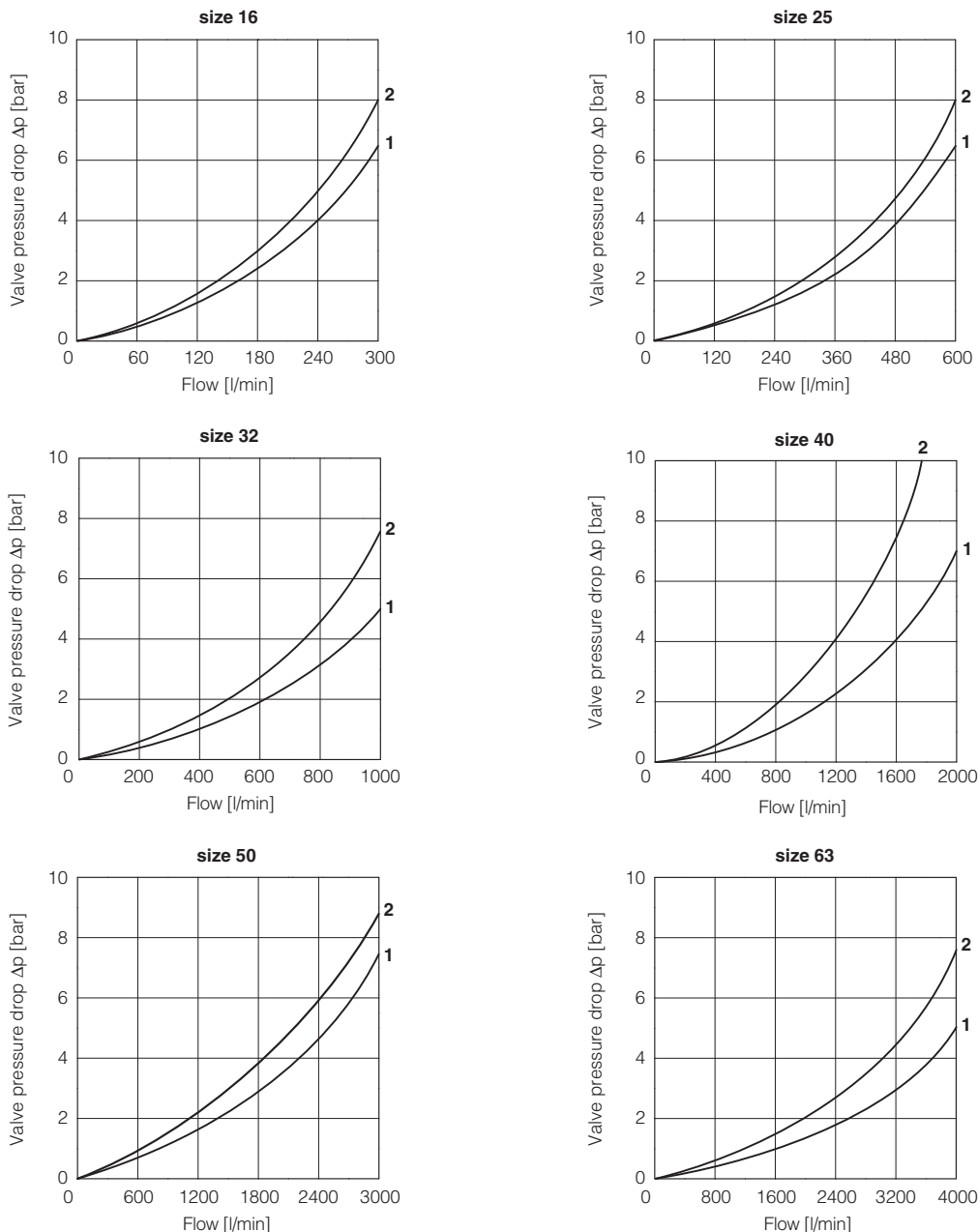

15 COVER INSTALLATION DIMENSIONS [mm] - for cartridge cavity dimensions see tech. table P006

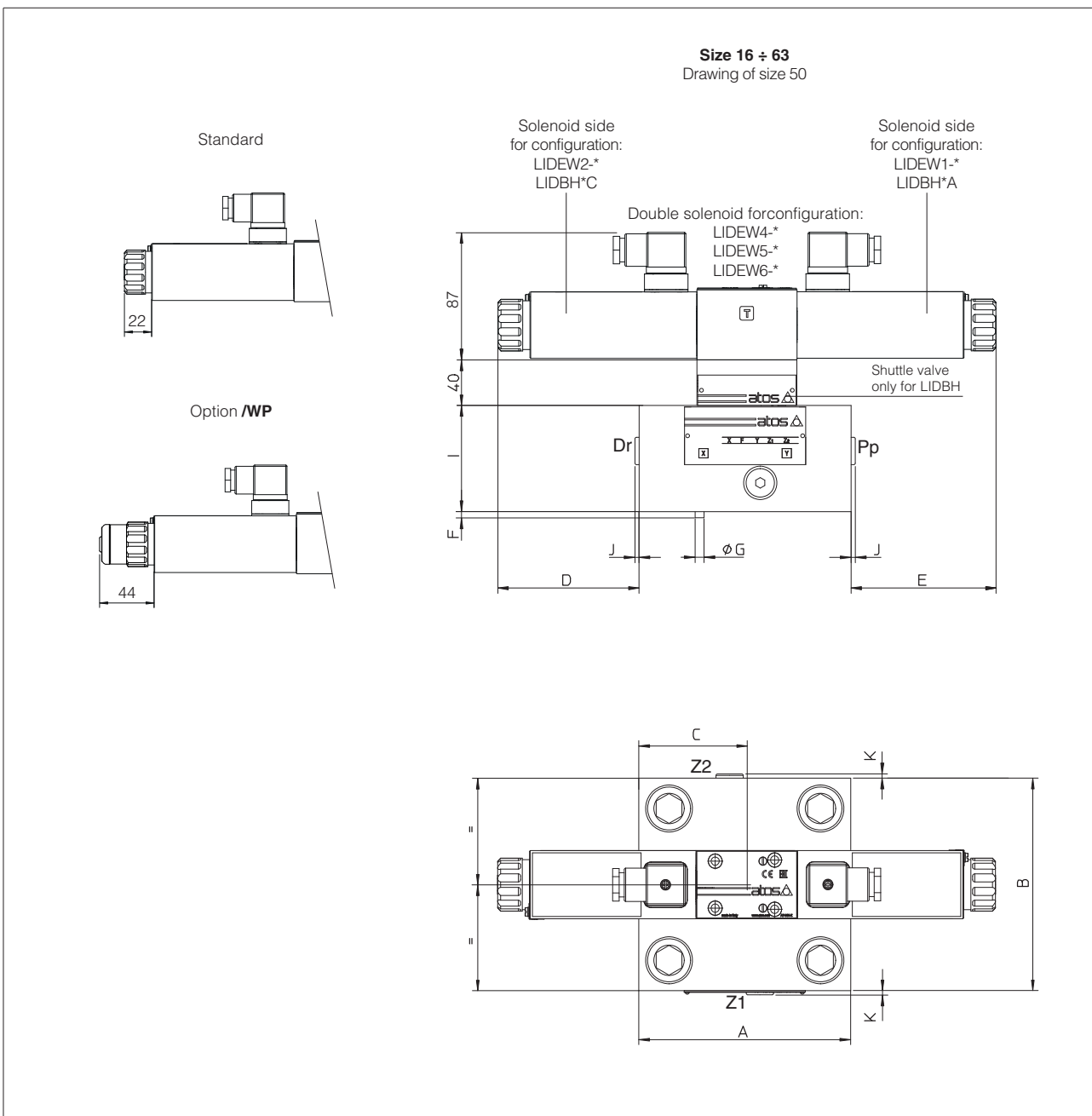

Notes referred to the below table:

- (1) LIDEW1* - LIDBH*A: solenoid at side of port Y of cover
- LIDEW2* - LIDBH*C: solenoid at side of port X of cover

Size (1)	A	B	C	D max	E max	F	G	I	J	K	Ports Pp-Dr	Ports Z1-Z2	Seals	Fastening bolts (3)	Tightening torque [Nm]	Mass [Kg]
16	70	65	41	142.5	130.5	4	3	40	-	-	-	-	4 OR-108	Nr. 4 M8x45	35	3,95 ÷ 5,7
25	85	85	42,5	129	129	6	5	40	-	-	-	-	4 OR-108	Nr. 4 M12x45	125	4,35 ÷ 6,1
32	100	100	50	121.5	121.5	6	5	50	-	-	-	-	4 OR-2043	Nr. 4 M16x55	300	4,85 ÷ 6,7
40	125	125	62,5	109	109	6	5	60	3,5	-	G 1/4	-	4 OR-3043	Nr. 4 M20x70	600	7,75 ÷ 9,6
50	140	140	70	101.5	101.5	4	6	70	3,5	3,5	G 1/4	G 1/4	4 OR-3043	Nr. 4 M20x80	600	10,85 ÷ 12,7
63	180	180	90	81.5	81.5	4	6	80	3,5	3,5	G 3/8	G 3/8	4 OR-3050	Nr. 4 M30x90	2100	18,65 ÷ 20,4

16 RELATED DOCUMENTATION

X010	Basics for electrohydraulics in hazardous environments
X050	Summary of Atos intrinsically safe components certified to ATEX, IECEx, EAC
EX950	Operating and maintenance information for intrinsically safe valves
P006	Mounting surfaces and cavities for cartridge valves