



### 3 OFF-BOARD ELECTRONIC DRIVER - only for R

|               |                       |
|---------------|-----------------------|
| Drivers model | E-BM-RES              |
| Type          | Digital               |
| Format        | DIN rail panel format |
| Tech table    | GS203                 |

### 4 GENERAL NOTES

Atos digital proportionals valves are CE marked according to the applicable directives (e.g. Immunity and Emission EMC Directive). Installation, wirings and start-up procedures must be performed according to the general prescriptions shown in tech table **FS900** and in the user manuals included in the E-SW-\* programming software.

### 5 VALVE SETTINGS AND PROGRAMMING TOOLS

Valve's functional parameters and configurations, can be easily set and optimized using Atos E-SW programming software connected via USB port to the digital.

For fieldbus versions, the software permits valve's parameterization through USB port also if the driver is connected to the central machine unit via fieldbus.

The software is available in different versions according to the driver's options (see table **GS500**):

|                      |   |                  |               |
|----------------------|---|------------------|---------------|
| <b>E-SW-BASIC</b>    | support: NP (USB)   | PS (Serial)      | IR (Infrared) |
| <b>E-SW-FIELDBUS</b> | support: BC (CANopen)   | BP (PROFIBUS DP) | EH (EtherCAT) |
|                      | EW (POWERLINK)  | EI (EtherNet/IP) | EP (PROFINET) |
| <b>E-SW-*/PQ</b>     | support: valves with SP, SF, SL alternated control (e.g. E-SW-BASIC/PQ) |                  |               |



**WARNING: drivers USB port is not isolated!** For E-C-SB-USB/M12 cable, the use of isolator adapter is highly recommended for PC protection



**WARNING:** see tech table **GS500** for the list of countries where the Bluetooth adapter has been approved

#### USB or Bluetooth connection

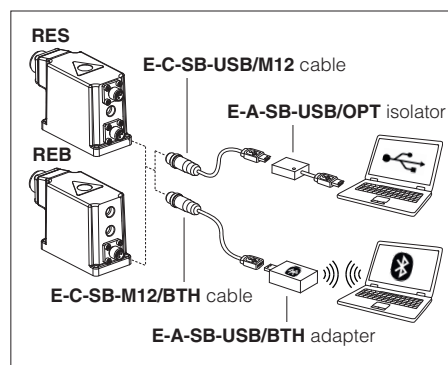

### 6 SMART TUNING

Smart tuning allows to adjust the valve dynamic response in order to match different hydraulic conditions and performance requirements.

The valve is provided with 3 factory settings for the pressure control:

- **dynamic** fast response time for best dynamic performances. Default factory setting for pressure valves
- **balanced** average response time suitable for major applications
- **smooth** attenuated response time for slow regulation without overshoots

Smart tuning setting can be switched from Dynamic (default) to Balanced or Smooth via software or fieldbus; if requested, performances can be further customized directly tuning each single control parameter. For details consult related manuals E-MAN-RI-\* and Quickstart, see section [24](#).

Below indications have to be considered as a general guideline, being affected by hydraulic circuit stiffness, working flow and dead volume.

**High stiffness - Low flow - Small volume**

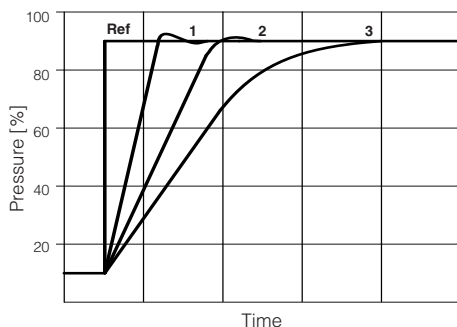

- 1 = dynamic
- 2 = balanced
- 3 = smooth

**Low stiffness - High flow - Large volume**

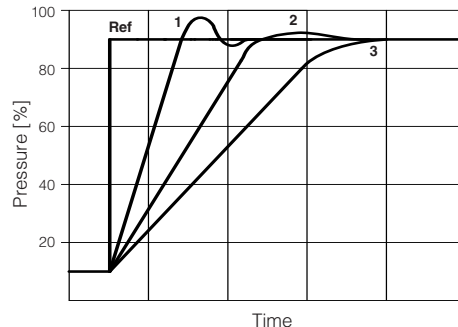

- 1 = dynamic
- 2 = balanced
- 3 = smooth

### 7 FIELDBUS - only for RES, see tech. table **GS510**

Fieldbus allows valve direct communication with machine control unit for digital reference, valve diagnostics and settings. These execution allow to operate the valves through fieldbus or analog signals available on the main connector.

### 8 GENERAL CHARACTERISTICS

|  |   |
|--|---|
| Assembly position                      | Any position  |
| Subplate surface finishing to ISO 4401 | Acceptable roughness index: Ra ≤ 0,8, recommended Ra 0,4 – Flatness ratio 0,01/100  |
| MTTFd valves according to EN ISO 13849 | 75 years, see technical table P007  |
| Ambient temperature range              | <b>R:</b> Standard = -20°C ÷ +70°C /PE option = -20°C ÷ +70°C /BT option = -40°C ÷ +60°C<br><b>REB, RES:</b> Standard = -20°C ÷ +60°C /PE option = -20°C ÷ +60°C /BT option = -40°C ÷ +60°C |
| Storage temperature range              | <b>R:</b> Standard = -20°C ÷ +80°C /PE option = -20°C ÷ +80°C /BT option = -40°C ÷ +70°C<br><b>REB, RES:</b> Standard = -20°C ÷ +70°C /PE option = -20°C ÷ +70°C /BT option = -40°C ÷ +70°C |
| Surface protection                     | Zinc coating with black passivation, galvanic treatment (driver housing for REB and RES)  |
| Corrosion resistance                   | Salt spray test (EN ISO 9227) > 200 h   |
| Compliance                             | CE according to EMC directive 2014/30/EU (Immunity: EN 61000-6-2; Emission: EN 61000-6-3)<br>RoHS Directive 2011/65/EU as last update by 2015/863/EU<br>REACH Regulation (EC) n°1907/2006   |

**9 HYDRAULIC CHARACTERISTICS** - based on mineral oil ISO VG 46 at 50 °C

| Valve model   |         | AGMZO-*-10  | AGMZO-*-20 | AGMZO-*-32 |
|---|---------|---|------------|------------|
| Max regulated pressure  | [bar]   | 100; 210; 315; 350  |            |            |
| Max pressure at port P  | [bar]   | 350   |            |            |
| Max pressure at port T  | [bar]   | 210   |            |            |
| Min regulated pressure  | [bar]   | see min. pressure / flow diagrams at section <a href="#">12</a> |            |            |
| Max flow  | [l/min] | 200   | 400        | 600        |
| Response time 0-100% step signal (depending on installation) <b>(1)</b> | [ms]    | ≤ 80  | ≤ 100      | ≤ 115      |
| Hysteresis  |         | ≤ 0,5 [% of max pressure]                                       |            |            |
| Linearity   |         | ≤ 1,0 [% of max pressure]                                       |            |            |
| Repeatability   |         | ≤ 0,2 [% of max pressure]                                       |            |            |
| Thermal drift   |         | zero point displacement < 1% at ΔT = 40°C                       |            |            |

**Note:** above performance data refer to valves coupled with Atos electronic drivers, see section [3](#)

**(1)** Average response time value; the pressure variation in consequence of a modification of the reference input signal to the valve is affected by the stiffness of the hydraulic circuit: greater is the stiffness of the circuit, faster is the dynamic response, see section [6](#)

**10 ELECTRICAL CHARACTERISTICS**

|                                  |  |                                   |  |   |
|----------------------------------|--|-----------------------------------|--|---|
| Power supplies                   | Nominal : +24 VDC<br>Rectified and filtered : VRMS = 20 ÷ 32 VMAX (ripple max 10 % VPP)  |                                   |  |   |
| Max power consumption            | <b>R</b> = 30 W  | <b>REB, RES</b> = 50 W            |  |   |
| Max. solenoid current            | 2,6 A  |                                   |  |   |
| Coil resistance R at 20°C        | 3 ÷ 3,3 Ω  |                                   |  |   |
| Analog input signals             | Voltage: range ±10 VDC (24 VMAX tollerant)<br>Current: range ±20 mA  |                                   | Input impedance: Ri > 50 kΩ<br>Input impedance: Ri = 500 Ω |   |
| Monitor output                   | Voltage: maximum range 0 ÷ 10 VDC @ max 5 mA<br>Current: maximum range 0 ÷ 20 mA @ max 500 Ω load resistance   |                                   |  |   |
| Enable input                     | Range: 0 ÷ 9 VDC (OFF state), 15 ÷ 24 VDC (ON state), 9 ÷ 15 VDC (not accepted); Input impedance: Ri > 87 kΩ   |                                   |  |   |
| Fault output                     | Output range : 0 ÷ 24 VDC (ON state ≡ VL+ [logic power supply] ; OFF state ≡ 0 V) @ max 50 mA;<br>external negative voltage not allowed (e.g. due to inductive loads)                  |                                   |  |   |
| Pressure transducer <b>(1)</b>   | E-ATR-8*/I Output signal: 4 ÷ 20 mA (see tech table <b>GS465</b> )   |                                   |  |   |
| Alarms                           | Solenoid not connected/short circuit, cable break with current reference signal, over/under temperature, current control monitoring, power supplies level, pressure transducer failure |                                   |  |   |
| Insulation class                 | H (180°) Due to the occurring surface temperatures of the solenoid coils, the European standards ISO 13732-1 and EN982 must be taken into account                                      |                                   |  |   |
| Protection degree to DIN EN60529 | <b>R</b> = IP65; <b>REB, RES</b> = IP66 / IP67 with mating connectors  |                                   |  |   |
| Duty factor                      | Continuous rating (ED=100%)  |                                   |  |   |
| Tropicalization                  | Tropical coating on electronics PCB  |                                   |  |   |
| Additional characteristics       | Short circuit protection of solenoid's current supply; current control by P.I.D. with rapid solenoid switching; protection against reverse polarity of power supply                    |                                   |  |   |
| Communication interface          | USB<br>Atos ASCII coding   | CANopen<br>EN50325-4 + DS408      | PROFIBUS DP<br>EN50170-2/IEC61158                          | EtherCAT<br>EC 61158                    |
| Communication physical layer     | not insulated<br>USB 2.0 + USB OTG   | optical insulated<br>CAN ISO11898 | optical insulated<br>RS485                                 | Fast Ethernet, insulated<br>100 Base TX |
| Recommended wiring cable         | LiYCY shielded cables, see section <a href="#">21</a>  |                                   |  |   |

**(1)** In case of pressure transducer failure, the valve's reaction can be configured through Atos E-SW software to:  
 - cut off the current to solenoid, therefore the regulated pressure will be reduced to minimum value (default setting)  
 - automatically switch the pressure control from closed loop (dynamic, balanced, smooth) to open loop, to let the valve to temporarily operate with reduced regulation accuracy

**Note:** a maximum time of 500 ms (depending on communication type) have be considered between the driver energizing with the 24 Vdc power supply and when the valve is ready to operate. During this time the current to the valve coils is switched to zero.

**11 SEALS AND HYDRAULIC FLUIDS** - for other fluids not included in below table, consult our technical office

|                                      |  |  |                             |
|--------------------------------------|--|--|-----------------------------|
| Seals, recommended fluid temperature | NBR seals (standard) = -20°C ÷ +60°C (+80°C for <b>R</b> ), with HFC hydraulic fluids = -20°C ÷ +50°C<br>FKM seals (/PE option) = -20°C ÷ +80°C<br>NBR low temp. seals (/BT option) = -40°C ÷ +60°C, with HFC hydraulic fluids = -40°C ÷ +50°C |  |                             |
| Recommended viscosity                | 20 ÷ 100 mm²/s - max allowed range 15 ÷ 380 mm²/s  |  |                             |
| Max fluid contamination level        | normal operation   | ISO4406 class 18/16/13 NAS1638 class 7 | see also filter section at  |
|                                      | longer life  | ISO4406 class 16/14/11 NAS1638 class 5 | www.atos.com or KTF catalog |
| <b>Hydraulic fluid</b>               | <b>Suitable seals type</b>   | <b>Classification</b>                  | <b>Ref. Standard</b>        |
| Mineral oils                         | NBR, FKM, NBR low temp.  | HL, HLP, HLPD, HVLP, HVLPD             | DIN 51524                   |
| Flame resistant without water        | FKM  | HF DU, HF DR                           | ISO 12922                   |
| Flame resistant with water           | NBR, NBR low temp.   | HFC                                    |                             |

**12 DIAGRAMS** (based on mineral oil ISO VG 46 at 50 °C)

**1 = Regulation diagrams**  
with flow rate Q = 50 l/min

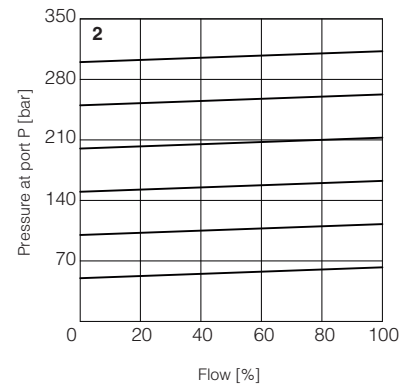
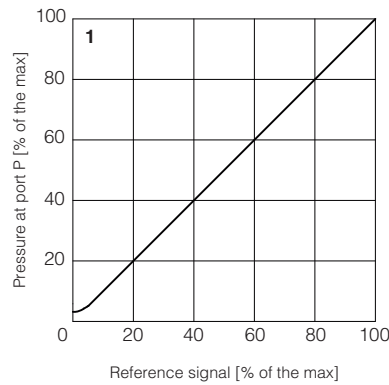

**2 = Pressure/flow diagrams**  
with reference signal set at Q = 50 l/min

**3-8 = Min. pressure/flow diagrams**  
with zero reference signal

- 3 = AGMZO\*-10/100, 210, 315
- 4 = AGMZO\*-10/350
- 5 = AGMZO\*-20/100, 210, 315
- 6 = AGMZO\*-20/350
- 7 = AGMZO\*-32/100, 210, 315
- 8 = AGMZO\*-32/350

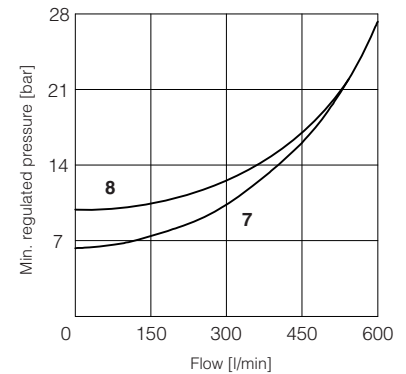
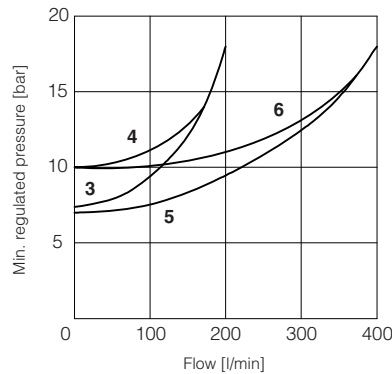

**13 HYDRAULIC OPTIONS**

- E** = External pilot option to be selected when the pilot pressure is supplied from a different line respect to the P main line.  
With option E the internal connection between port P and X of the valve is plugged.  
The pilot pressure must be connected to the X port available on the valve's mounting surface or on main body (threaded pipe connection G 1/4").
- Y** = The external drain is mandatory in case the main line T is subjected to pressure peaks or it is pressurized.  
The Y drain port has a threaded connection G 1/4" available on the pilot stage body.

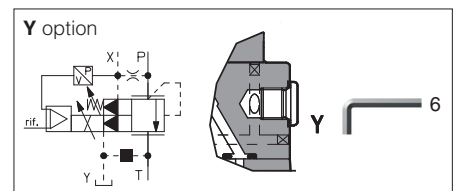
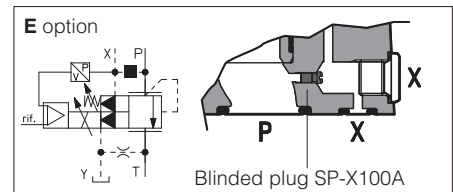

**14 ELECTRONICS OPTIONS** - only for **REB** and **RES**

- I** = This option provides 4 ÷ 20 mA current reference and monitor signals, instead of the standard 0 ÷ 10 VDC. Input signal can be reconfigured via software selecting between voltage and current, within a maximum range of ±10 Vdc or ±20 mA.  
It is normally used in case of long distance between the machine control unit and the valve or where the reference signal can be affected by electrical noise; the valve functioning is disabled in case of reference signal cable breakage.
- Q** = This option permits to inhibit the valve function without removing the power supply to the driver. Upon disable command the current to the solenoid is zeroed and the valve's spool moves to rest position.  
The option /Q is suggested for all cases where the valve has to be frequently inhibited during the machine cycle – see 19.5 for signal specifications.
- Z** = This option provides, on the 12 pin main connector, the following additional features:  
**Fault output signal** - see 19.6  
**Enable input signal** - see above option /Q  
**Power supply for driver's logics and communication** - see 19.2

**15 POSSIBLE COMBINED OPTIONS**

- Hydraulic options:** all combination possible  
**Electronics options:** /IQ, /IZ

## 16 MECHANICAL PRESSURE LIMITER

The AGMZO are provided with mechanical pressure limiter acting as protection against overpressure. For safety reasons the factory setting of the mechanical pressure limiter is fully unloaded (min pressure). At the first commissioning it must be set at a value lightly higher than the max pressure regulated with the proportional control.

For the pressure setting of the mechanical pressure limiter, proceed according to following steps:

- apply the max reference input signal to the valve's driver. The system pressure will not increase until the mechanical pressure limiter remains unloaded.
- turn clockwise the adjustment screw ① until the system pressure will increase up to a stable value corresponding to the pressure setpoint at max reference input signal.
- turn clockwise the adjustment screw ① of additional 1 or 2 turns to ensure that the mechanical pressure limiter remains closed during the proportional valve working.

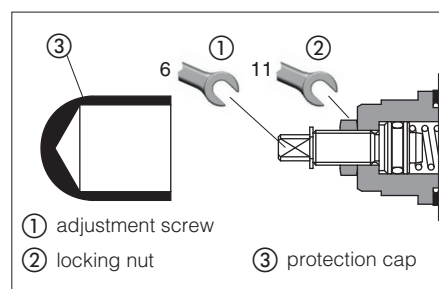

## 17 REMOTE PRESSURE UNLOADING

The **P** main line can be remotely unloaded by connecting the valve X port to a solenoid valve as shown in the below scheme (venting valve).

This function can be used in emergency to unload the system pressure by-passing the proportional control.

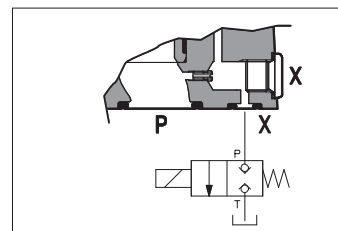

## 18 AIR BLEEDING

At the first valve commissioning the air eventually trapped inside the solenoid must be bled-off through the screw ① located at the rear side of the solenoid housing.

The presence of air may cause pressure instability and vibrations.

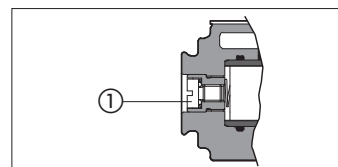

## 19 POWER SUPPLY AND SIGNALS SPECIFICATIONS - only for **REB** and **RES**

Generic electrical output signals of the valve (e.g. fault or monitor signals) must not be directly used to activate safety functions, like to switch-ON/OFF the machine's safety components, as prescribed by the European standards (Safety requirements of fluid technology systems and components-hydraulics, ISO 4413).

### 19.1 Power supply (V+ and V0)

The power supply must be appropriately stabilized or rectified and filtered: apply at least a 10000  $\mu$ F/40 V capacitance to single phase rectifiers or a 4700  $\mu$ F/40 V capacitance to three phase rectifiers. In case of separate power supply see 19.2.

⚠ A safety fuse is required in series to each power supply: 2,5 A time lag fuse.

### 19.2 Power supply for driver's logic and communication (VL+ and VL0) - only for **/Z**

The power supply for driver's logic and communication must be appropriately stabilized or rectified and filtered: apply at least a 10000  $\mu$ F/40 V capacitance to single phase rectifiers or a 4700  $\mu$ F/40 V capacitance to three phase rectifiers.

The separate power supply for driver's logic on pin 9 and 10, allow to remove solenoid power supply from pin 1 and 2 maintaining active the diagnostics, USB and fieldbus communications.

⚠ A safety fuse is required in series to each driver's logic and communication power supply: 500 mA fast fuse.

### 19.3 Pressure reference input signal (P\_INPUT+)

The driver controls in closed loop the current to the valve pressure proportionally to the external reference input signal.

Reference input signal is factory preset according to selected valve code, defaults are 0  $\div$  10 Vdc for standard and 4  $\div$  20 mA for /I option.

Input signal can be reconfigured via software selecting between voltage and current, within a maximum range of  $\pm$ 10 VDC or  $\pm$  20 mA.

Drivers with fieldbus interface (BC, BP, EH) can be software set to receive reference signal directly by the machine control unit (fieldbus reference).

Analog reference input signal can be used as on-off commands with input range 0  $\div$  24 Vdc.

### 19.4 Pressure monitor output signal (P\_MONITOR)

The driver generates an analog output signal proportional to the actual pressure of the valve; the monitor output signal can be software set to show other signals available in the driver (e.g. analog reference, fieldbus reference).

Monitor output signal is factory preset according to selected valve code, defaults settings are 0  $\div$  10 Vdc for standard and 4  $\div$  20 mA for /I option.

Output signal can be reconfigured via software selecting between voltage and current, within a maximum range of 0  $\div$  10 Vdc or 0  $\div$  20 mA.

### 19.5 Enable input signal (ENABLE) - not for standard

To enable the driver, supply a 24 Vdc on pin 3 (pin C): Enable input signal allows to enable/disable the current supply to the solenoid, without removing the electrical power supply to the driver; it is used to active the communication and the other driver functions when the valve must be disabled for safety reasons. This condition **does not comply** with norms IEC 61508 and ISO 13849.

Enable input signal can be used as generic digital input by software selection.

### 19.6 Fault output signal (FAULT) - only for **/Z** option

Fault output signal indicates fault conditions of the driver (solenoid short circuits/not connected, reference signal broken for 4  $\div$  20 mA input, etc.).

Fault presence corresponds to 0 VDC, normal working corresponds to 24 VDC.

Fault status is not affected by the Enable input signal.

**20 ELECTRONIC CONNECTIONS**

**20.1 Main connector signals - 7 pin (A1) Standard and /Q option - for REB and RES**

| PIN | Standard                       | /Q     | TECHNICAL SPECIFICATIONS   | NOTES  |
|-----|--------------------------------|--------|--|--|
| A   | V+                             |        | Power supply 24 Vdc Rectified and filtered: $V_{RMS} = 20 \div 32 V_{MAX}$ (ripple max 10 % $V_{PP}$ )   | Input - power supply                                 |
| B   | V0                             |        | Power supply 0 Vdc   | Gnd - power supply                                   |
| C   | AGND                           |        | Analog ground  | Gnd - analog signal                                  |
|     |                                | ENABLE | Enable (24 Vdc) or disable (0 Vdc) the driver, referred to V0  | Input - on/off signal                                |
| D   | P_INPUT+                       |        | Pressure reference input signal: $\pm 10$ Vdc / $\pm 20$ mA maximum range<br>Defaults are 0 $\div$ 10 Vdc for standard and 4 $\div$ 20 mA for /I option      | Input - analog signal<br><b>Software selectable</b>  |
| E   | INPUT-                         |        | Negative reference input signal for P_INPUT+   | Input - analog signal                                |
| F   | P_MONITOR referred to:<br>AGND | V0     | Pressure monitor output signal: 0 $\div$ 10 Vdc / 0 $\div$ 20 mA maximum range<br>Defaults are 0 $\div$ 10 Vdc for standard and 4 $\div$ 20 mA for /I option | Output - analog signal<br><b>Software selectable</b> |
| G   | EARTH                          |        | Internally connected to driver housing   |  |

**20.2 Main connector signals - 12 pin (A2) /Z option - for REB and RES**

| PIN | /Z        | TECHNICAL SPECIFICATIONS  | NOTES  |
|-----|-----------|---|--|
| 1   | V+        | Power supply 24 Vdc Rectified and filtered: $V_{RMS} = 20 \div 32 V_{MAX}$ (ripple max 10 % $V_{PP}$ )  | Input - power supply                                 |
| 2   | V0        | Power supply 0 Vdc  | Gnd - power supply                                   |
| 3   | ENABLE    | Enable (24 Vdc) or disable (0 Vdc) the driver, referred to VLO  | Input - on/off signal                                |
| 4   | P_INPUT+  | Pressure reference input signal: $\pm 10$ Vdc / $\pm 20$ mA maximum range<br>Defaults are 0 $\div$ 10 Vdc for standard and 4 $\div$ 20 mA for /I option                       | Input - analog signal<br><b>Software selectable</b>  |
| 5   | INPUT-    | Negative reference input signal for P_INPUT+  | Input - analog signal                                |
| 6   | P_MONITOR | Pressure monitor output signal: 0 $\div$ 10 Vdc / 0 $\div$ 20 mA maximum range, referred to VLO<br>Defaults are 0 $\div$ 10 Vdc for standard and 4 $\div$ 20 mA for /I option | Output - analog signal<br><b>Software selectable</b> |
| 7   | NC        | Do not connect  |  |
| 8   | NC        | Do not connect  |  |
| 9   | VL+       | Power supply 24 Vdc for driver's logic and communication  | Input - power supply                                 |
| 10  | VLO       | Power supply 0 Vdc for driver's logic and communication   | Gnd - power supply                                   |
| 11  | FAULT     | Fault (0 Vdc) or normal working (24 Vdc), referred to VLO   | Output - on/off signal                               |
| PE  | EARTH     | Internally connected to driver housing  |  |

**Note:** do not disconnect VLO before VL+ when the driver is connected to PC USB port

**20.3 Communication connectors - for REB (B) and RES (B) - (C)**

**(B) USB connector - M12 - 5 pin** always present

| PIN | SIGNAL  | TECHNICAL SPECIFICATION (1) |
|-----|---------|-----------------------------|
| 1   | +5V_USB | Power supply                |
| 2   | ID      | Identification              |
| 3   | GND_USB | Signal zero data line       |
| 4   | D-      | Data line -                 |
| 5   | D+      | Data line +                 |

**(C1) BC fieldbus execution, connector - M12 - 5 pin (2)**

| PIN | SIGNAL   | TECHNICAL SPECIFICATION (1) |
|-----|----------|-----------------------------|
| 1   | CAN_SHLD | Shield                      |
| 2   | NC       | do not connect              |
| 3   | CAN_GND  | Signal zero data line       |
| 4   | CAN_H    | Bus line (high)             |
| 5   | CAN_L    | Bus line (low)              |

**(C2) BP fieldbus execution, connector - M12 - 5 pin (2)**

| PIN | SIGNAL | TECHNICAL SPECIFICATION (1)           |
|-----|--------|---------------------------------------|
| 1   | +5V    | Termination supply signal             |
| 2   | LINE-A | Bus line (high)                       |
| 3   | DGND   | Data line and termination signal zero |
| 4   | LINE-B | Bus line (low)                        |
| 5   | SHIELD |                                       |

**(C3) (C4) EH fieldbus execution, connector - M12 - 4 pin (2)**

| PIN     | SIGNAL | TECHNICAL SPECIFICATION (1) |
|---------|--------|-----------------------------|
| 1       | TX+    | Transmitter                 |
| 2       | RX+    | Receiver                    |
| 3       | TX-    | Transmitter                 |
| 4       | RX-    | Receiver                    |
| Housing | SHIELD |                             |

(1) Shield connection on connector's housing is recommended

(2) Only for RES execution

**20.4 Solenoid connection - only for R**

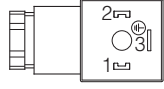
| PIN | SIGNAL | TECHNICAL SPECIFICATION | Connector code 666  |
|-----|--------|-------------------------|---|
| 1   | COIL   | Power supply            |  |
| 2   | COIL   | Power supply            |   |
| 3   | GND    | Ground                  |   |

**20.5 Pressure transducer connection - only for R**

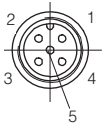
| PIN | SIGNAL | TECHNICAL SPECIFICATION      | Connector code ZBE-08   |
|-----|--------|------------------------------|---|
| 1   | V+     | Power supply                 |  |
| 2   | NC     | Not connected                |   |
| 3   | TR     | Output signal 4 $\div$ 20 mA |   |
| 4   | NC     | Not connected                |   |
| 5   | NC     | Not connected                |   |

## 20.6 REB connections layout

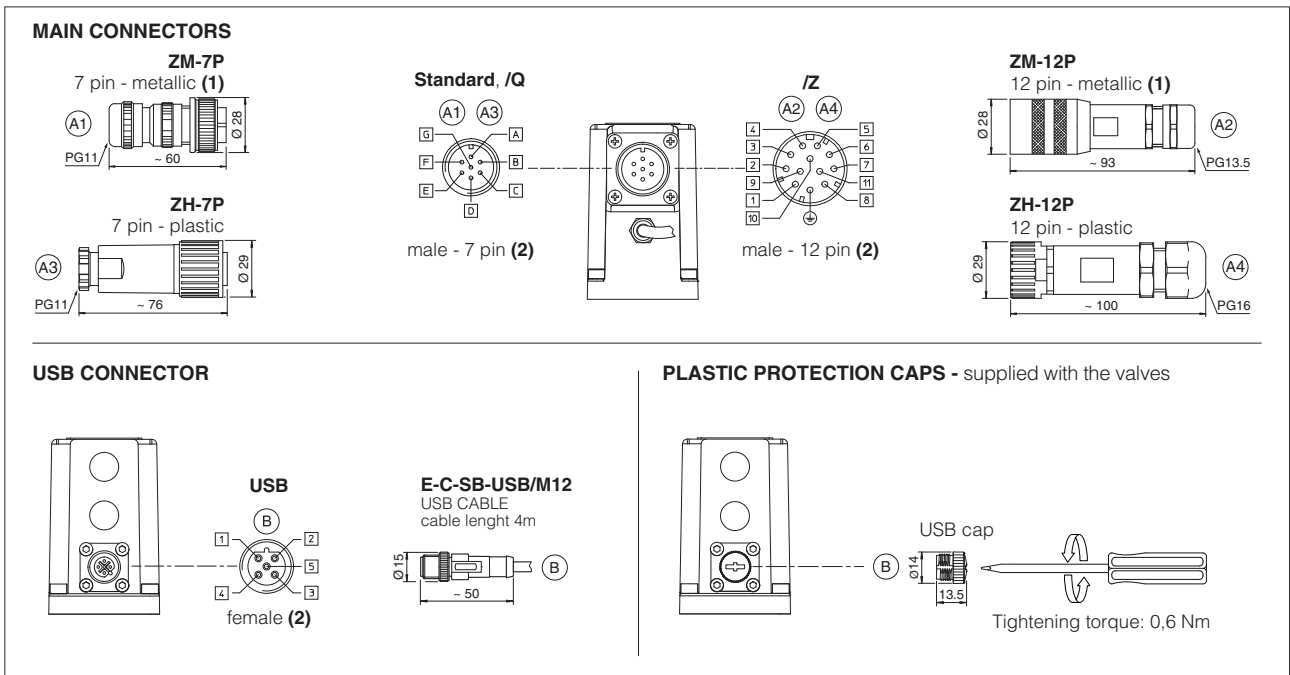

(1) Use of metallic connectors is strongly recommended in order to fulfill EMC requirements (2) Pin layout always referred to driver's view

## 20.7 RES connections layout

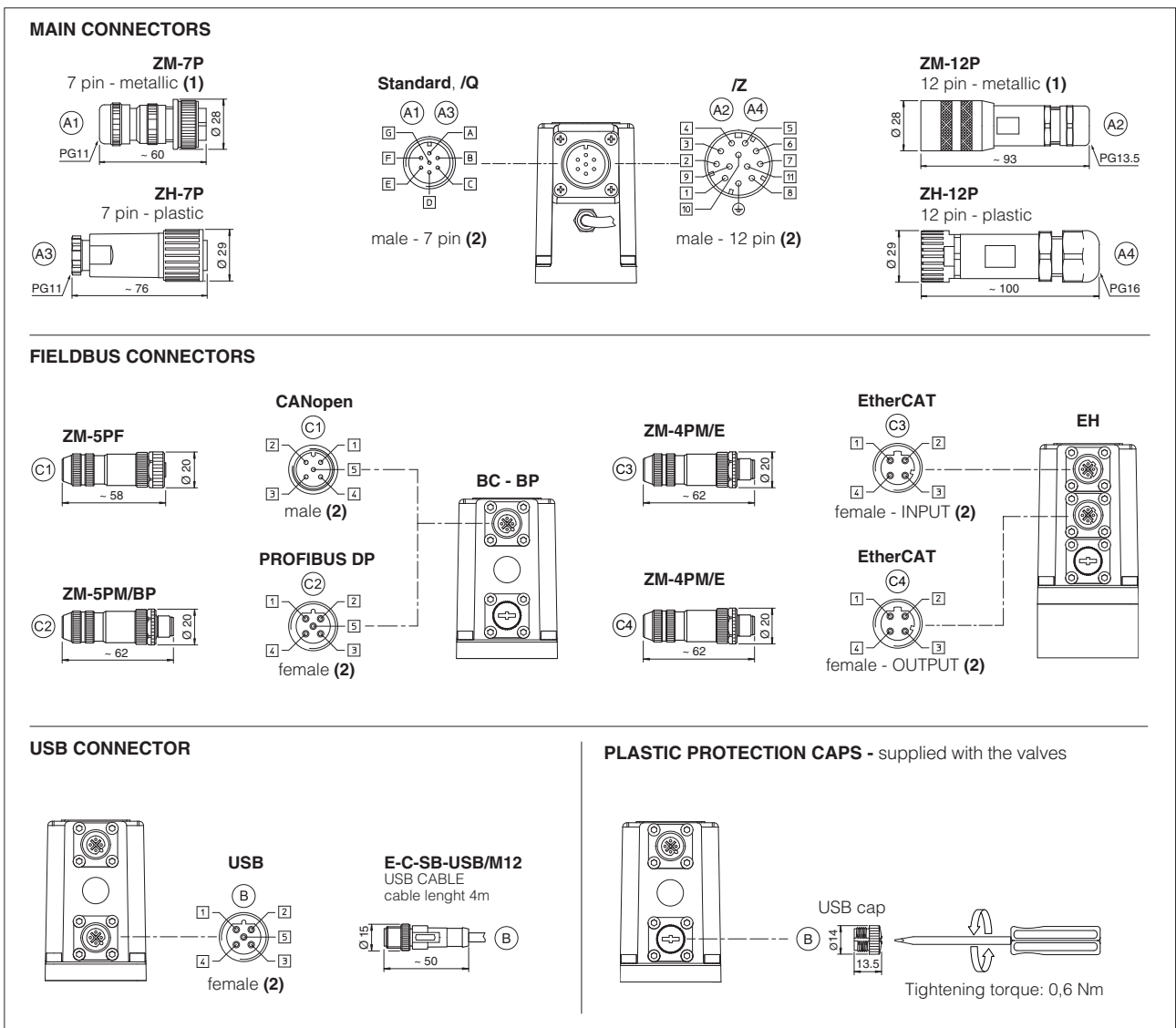

(1) Use of metallic connectors is strongly recommended in order to fulfill EMC requirements (2) Pin layout always referred to driver's view



**21 CONNECTORS CHARACTERISTICS** - to be ordered separately

**21.1 Main connectors - 7 pin - for REB and RES**

| CONNECTOR TYPE        | POWER SUPPLY   | POWER SUPPLY   |
|-----------------------|--|--|
| CODE                  | (A1) ZM-7P   | (A3) ZH-7P   |
| Type                  | 7pin female straight circular  | 7pin female straight circular  |
| Standard              | According to MIL-C-5015  | According to MIL-C-5015  |
| Material              | Metallic   | Plastic reinforced with fiber glass  |
| Cable gland           | PG11   | PG11   |
| Recommended cable     | LiYCY 7 x 0,75 mm <sup>2</sup> max 20 m (logic and power supply)<br>or LiYCY 7 x 1 mm <sup>2</sup> max 40 m (logic and power supply) | LiYCY 7 x 0,75 mm <sup>2</sup> max 20 m (logic and power supply)<br>or LiYCY 7 x 1 mm <sup>2</sup> max 40 m (logic and power supply) |
| Conductor size        | up to 1 mm <sup>2</sup> - available for 7 wires  | up to 1 mm <sup>2</sup> - available for 7 wires  |
| Connection type       | to solder  | to solder  |
| Protection (EN 60529) | IP 67  | IP 67  |

**21.2 Main connectors - 12 pin - for REB and RES**

| CONNECTOR TYPE        | POWER SUPPLY  | POWER SUPPLY  |
|-----------------------|---|---|
| CODE                  | (A2) ZM-12P   | (A4) ZH-12P   |
| Type                  | 12pin female straight circular                                      | 12pin female straight circular  |
| Standard              | DIN 43651   | DIN 43651   |
| Material              | Metallic  | Plastic reinforced with fiber glass   |
| Cable gland           | PG13,5  | PG16  |
| Recommended cable     | LiYCY 12 x 0,75 mm <sup>2</sup> max 20 m (logic and power supply)   | LiYCY 10 x 0,14mm <sup>2</sup> max 40 m (logic)<br>LiYY 3 x 1mm <sup>2</sup> max 40 m (power supply)                                      |
| Conductor size        | 0,5 mm <sup>2</sup> to 1,5 mm <sup>2</sup> - available for 12 wires | 0,14 mm <sup>2</sup> to 0,5 mm <sup>2</sup> - available for 9 wires<br>0,5 mm <sup>2</sup> to 1,5 mm <sup>2</sup> - available for 3 wires |
| Connection type       | to crimp  | to crimp  |
| Protection (EN 60529) | IP 67   | IP 67   |



**21.3 Fieldbus communication connectors - only for RES**

| CONNECTOR TYPE        | BC CANopen (1)                       |                              | BP PROFIBUS DP (1)                   |                              | EH EtherCAT (2)                      |  |
|-----------------------|--------------------------------------|------------------------------|--------------------------------------|------------------------------|--------------------------------------|--|
| CODE                  | (C1) ZM-5PF                          | (C2) ZM-5PM                  | (C1) ZM-5PF/BP                       | (C2) ZM-5PM/BP               | (C1) (C2) ZM-4PM/E                   |  |
| Type                  | 5 pin female straight circular       | 5 pin male straight circular | 5 pin female straight circular       | 5 pin male straight circular | 4 pin male straight circular         |  |
| Standard              | M12 coding A – IEC 61076-2-101       |                              | M12 coding B – IEC 61076-2-101       |                              | M12 coding D – IEC 61076-2-101       |  |
| Material              | Metallic                             |                              | Metallic                             |                              | Metallic                             |  |
| Cable gland           | Pressure nut - cable diameter 6÷8 mm |                              | Pressure nut - cable diameter 6÷8 mm |                              | Pressure nut - cable diameter 4÷8 mm |  |
| Cable                 | CANbus Standard (DR 303-1)           |                              | PROFIBUS DP Standard                 |                              | Ethernet standard CAT-5              |  |
| Connection type       | screw terminal                       |                              | screw terminal                       |                              | terminal block                       |  |
| Protection (EN 60529) | IP67                                 |                              | IP 67                                |                              | IP 67                                |  |

(1) E-TRM-\*\* terminators can be ordered separately - see tech table **GS500**

(2) Internally terminated

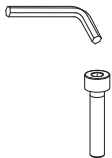
**22 FASTENING BOLTS AND SEALS**

|   | AGMZO-*-10   | AGMZO-*-20  | AGMZO-*-32  |
|---|--|---|---|
|  | <p><b>Fastening bolts:</b><br/>4 socket head screws M12x35 class 12.9<br/>Tightening torque = 125 Nm</p>               | <p><b>Fastening bolts:</b><br/>4 socket head screws M16x50 class 12.9<br/>Tightening torque = 300 Nm</p>                | <p><b>Fastening bolts:</b><br/>4 socket head screws M20x60 class 12.9<br/>Tightening torque = 600 Nm</p>                |
|  | <p><b>Seals:</b><br/>2 OR 123<br/>Diameter of ports P, T: Ø 14 mm<br/>1 OR 109/70<br/>Diameter of port X: Ø 3,2 mm</p> | <p><b>Seals:</b><br/>2 OR 4112<br/>Diameter of ports P, T: Ø 24 mm<br/>1 OR 109/70<br/>Diameter of port X: Ø 3,2 mm</p> | <p><b>Seals:</b><br/>2 OR 4131<br/>Diameter of ports P, T: Ø 28 mm<br/>1 OR 109/70<br/>Diameter of port X: Ø 3,2 mm</p> |



### SIZE 10

ISO 6264: 2007  
 Mounting surface: 6264-06-09-1-97  
 (see table P005)

|            | Mass [kg] |          |        |
|------------|-----------|----------|--------|
|            | R         | REB, RES | RES-EH |
| AGMZO-*-10 | 5,7       | 6,2      | 6,3    |

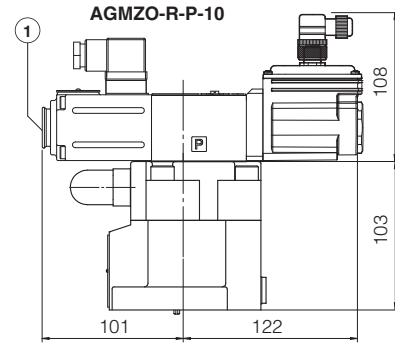
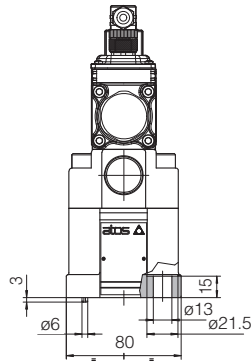

AGMZO-REB-P-NP-10  
 AGMZO-RES-P-BC-10  
 AGMZO-RES-P-BP-10

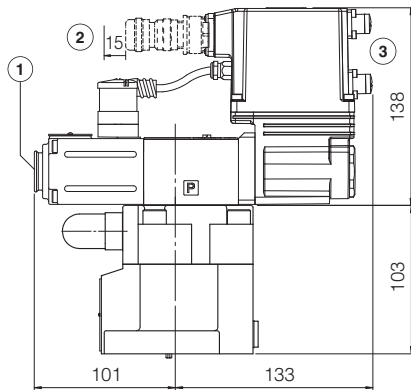

AGMZO-RES-P-EH-10

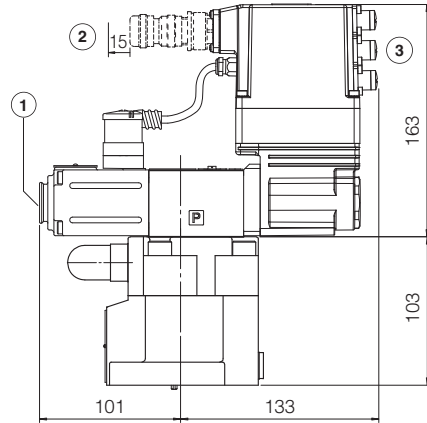

### SIZE 20

ISO 6264: 2007  
 Mounting surface: 6264-08-13-1-97  
 (see table P005)

|            | Mass [kg] |          |        |
|------------|-----------|----------|--------|
|            | R         | REB, RES | RES-EH |
| AGMZO-*-20 | 6,9       | 7,4      | 7,5    |

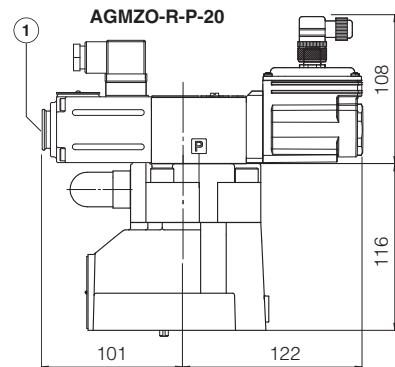
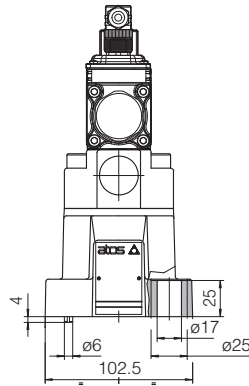

AGMZO-REB-P-NP-20  
 AGMZO-RES-P-BC-20  
 AGMZO-RES-P-BP-20

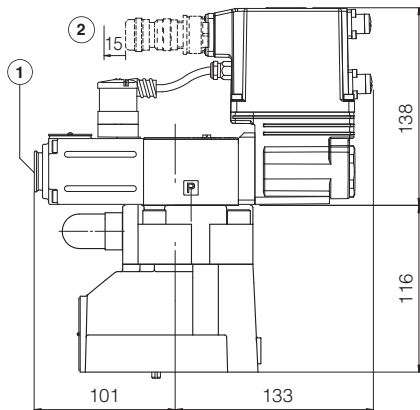

AGMZO-RES-P-EH-20

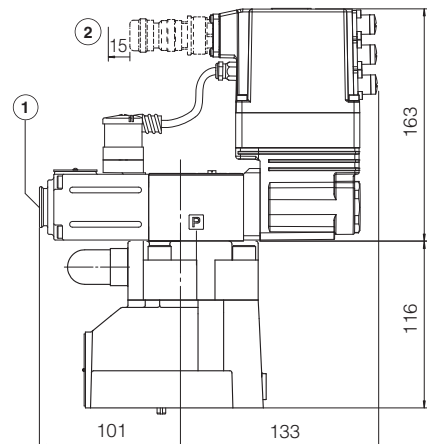

- ① = Air bleeding, see section 18
- ② = Space to remove the connectors
- ③ = The dimensions of all connectors must be considered, see section 20.6 and 20.7

## SIZE 32

ISO 6264: 2007

Mounting surface: 6264-10-17-1-97

(see table P005)

(with M20 fixing holes instead of standard M18)

|            | Mass [kg] |          |        |
|------------|-----------|----------|--------|
|            | R         | REB, AES | RES-EH |
| AGMZO-*-32 | 8,3       | 8,8      | 8,9    |

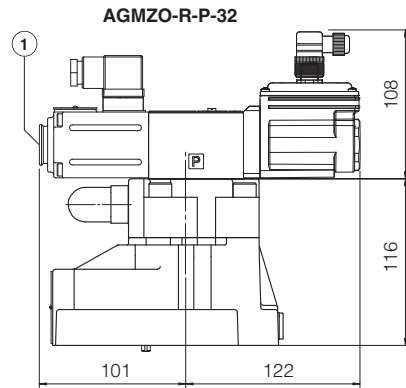
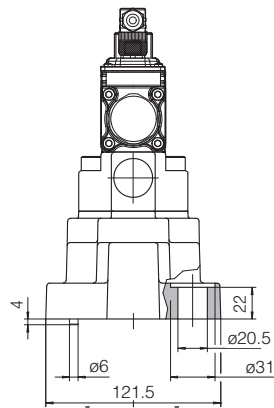

AGMZO-REB-P-NP-32  
AGMZO-RES-P-BC-32  
AGMZO-RES-P-BP-32

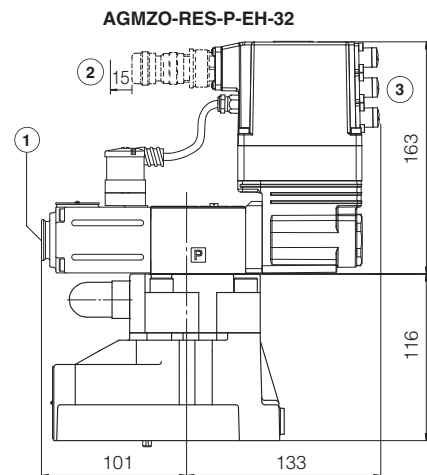
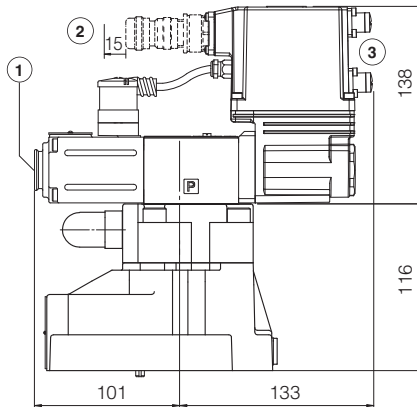

① = Air bleeding, see section 18 

② = Space to remove the connectors

③ = The dimensions of all connectors must be considered, see section 20.6 and 20.7

### 24 RELATED DOCUMENTATION

**FS001** Basics for digital electrohydraulics  
**FS900** Operating and maintenance information for proportional valves  
**GS203** E-BM-RES digital driver  
**GS500** Programming tools  
**GS510** Fieldbus  
**K800** Electric and electronic connectors

**P005** Mounting surfaces for electrohydraulic valves  
**QB400** Quickstart for REB valves commissioning  
**QF400** Quickstart for RES valves commissioning  
**E-MAN-BM-RES** RES user manual (off-board)  
**E-MAN-RI-REB** REB user manual  
**E-MAN-RI-RES** RES user manual